

# Sumitomo Drive Technologies

Sumitomo Machinery Corporation of America  
**Headquarters & Manufacturing**  
 4200 Holland Boulevard, Chesapeake, VA 23323



**Sumitomo Machinery Corp. of America**  
 Chesapeake, VA  
 Corona, CA  
 Glendale Heights, IL  
 Louisville, KY  
 Verona, VA

Phone: +1.757.485.3355  
 +1.951.340.4100  
 +1.630.752.0200  
 +1.502.969.0378  
 +1.540.213.2442

Fax: +1.757.485.7490  
 +1.951.340.4108  
 +1.630.752.0208  
 +1.502.969.0380  
 +1.540.213.2222

**SM Cyclo de Mexico, S.A. de C.V.**  
 Monterrey  
 Guadalajara  
 Ciudad de México

+52.81.8144.5130  
 +52.33.3675.4323  
 +52.55.2282.8700

+52.81.8144.5130 ext. 3109  
 +52.33.3675.4418  
 +52.55.2282.8700

**SM Cyclo of Canada, Ltd.**  
 Toronto, ON  
 Vancouver, BC

+1.905.469.1050  
 +1.604.525.5403

+1.905.469.1055  
 +1.604.525.0879

**SM Cyclo Colombia, S.A.S.**  
 Bogotá

+57.1.300.0673

+57.1.300.0673 ext. 105

**Sumitomo Indústrias Pesadas do Brasil Ltda.**  
 São Paulo

+55.11.4403.9292

+55.11.4403.9292

**SM Cyclo de Chile Ltda.**  
 Santiago  
 Antofagasta  
 Concepción

+56.2.2892.7000  
 +56.5.5256.1611  
 +56.41.246.9806

+56.2.2892.7001  
 +56.5.5256.1616  
 +56.41.246.9171

**SM Cyclo de Guatemala Ensambladora, Ltda.**  
 Guatemala

+502.6648.0500

+502.6648.9171

**SM Cyclo de Argentina, SA**  
 Buenos Aires

+54.3327.45.4095

+54.3327.45.4099

## World Headquarters

Japan  
 Sumitomo Heavy Industries, Ltd.  
 Power Transmission & Controls Group  
 ThinkPark Tower, 1-1, Osaki 2-chome,  
 Shinagawa-ku, Tokyo 141-6025 Japan  
 Tel: +81-367-37-2511 • Fax: +81-368-66-5160

[www.sumitomodrive.com](http://www.sumitomodrive.com)  
**E-mail: [Customer\\_Service@suminet.com](mailto:Customer_Service@suminet.com)**

Catalog 13.402.50.003  
 ©2024 Sumitomo Machinery Corporation of America Printed in USA

Sumitomo Drive Technologies

CYCLO® BBB4 BEVEL BUDDYBOX®

Gearmotors

# Sumitomo Drive Technologies

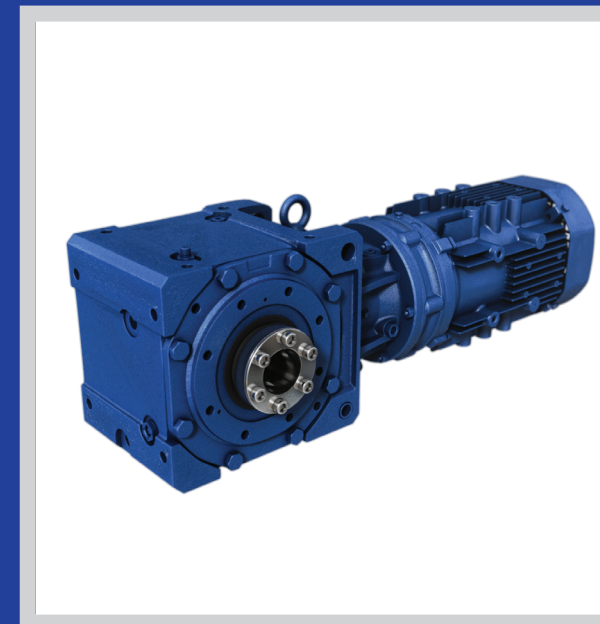

**CYCLO® BBB4  
 BEVEL BUDDYBOX®**  
 Gearmotors



## EPNA Motors (1 HP+)

Enhanced Performance (EP,NA) integral motors represent exceptional value to customers. To maximize the performance of the motors, a host of advanced features has been developed providing tangible benefits to the users.

### All in one

To simplify transactions throughout the continent, North American version (.NA) features standard multiple listings including DOE, UL and CSA, along with CE marking. Other versions are available for premium performance with European 50 Hz voltages.

### Exceptionally long life

Our Premium Efficient Motors feature lower temperature rise and robust class "F" insulation. The combination of those attributes yield reduced motor operating temperatures that exponentially increase the thermal life of the insulation.

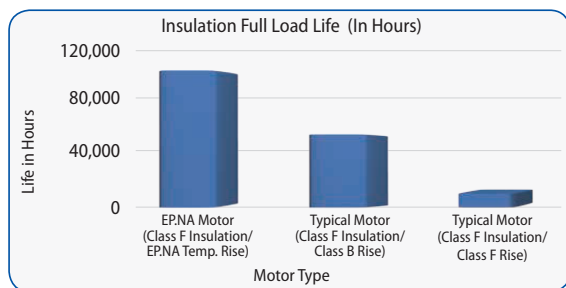

### Eco friendly

Premium efficiency, mandated by the DOE, shrinks the carbon footprint by delivering more torque at the same level of energy consumption. Higher starting torques may allow smaller motors to be selected for some applications.

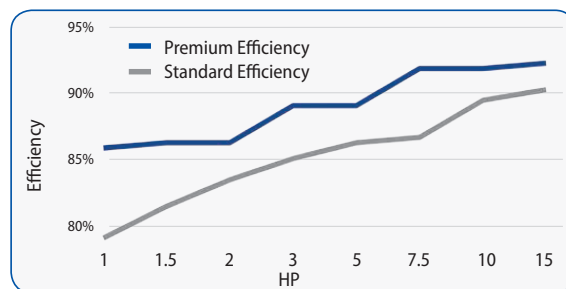

Get Pricing and CAD models for Sumitomo Drive Technologies products today at [www.sumitomodrive.com/Configurator](http://www.sumitomodrive.com/Configurator)

### Cost-effective

The premium efficiency design is cost-effective in reducing energy consumption throughout the full speed range, resulting in a lower total lifecycle cost.

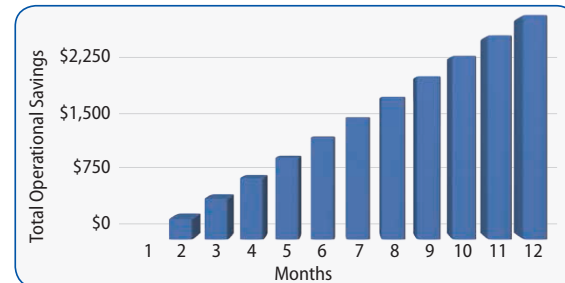

The assumptions for the study are as follows:  
 9.8 cents of a dollar per kWh • 8600 operating hours annually • A 7.5 kilowatt motor (10 HP) • IE3 motor costing 25% more than the IE1 motor • IE3 premium efficiency motor being 2.8% more efficient than the IE1 standard efficiency motor

### Inverter duty

All of the motors feature corona resistant magnet wire that resists the voltage spikes that are inherent to the widely applied IGBT inverters and extends insulation life. Inverter duty brake motors are also available. The non-brake motors are suitable for a 10:1 turndown. The advanced fan design helps to keep the motor running cool at lower input speeds.

### Optimized Geometry

Increasing motor size is one of several techniques to reduce losses and achieve premium efficiency. Sumitomo optimized its existing external envelope while still accommodating a large motor core. The result is a compact premium efficient motor.

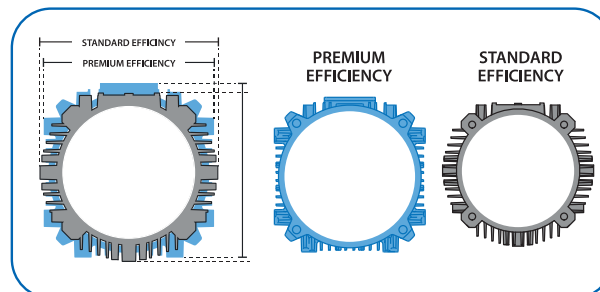

E-mail: [Customer\\_Service@suminet.com](mailto:Customer_Service@suminet.com)



Product Configurator: [www.sumitomodrive.com/Configurator](http://www.sumitomodrive.com/Configurator)

Sumitomo Drive Technologies' online product Configurator streamlines the selection process, enabling you to build **our power transmission products for your specific application.**

Configure your Sumitomo Drive Technologies products today at [www.sumitomodrive.com/Configurator](http://www.sumitomodrive.com/Configurator)

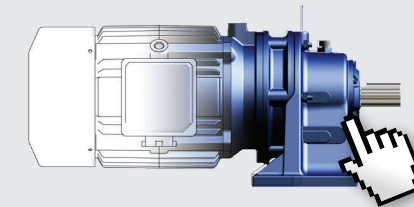

Scan with a QR code reader to login!

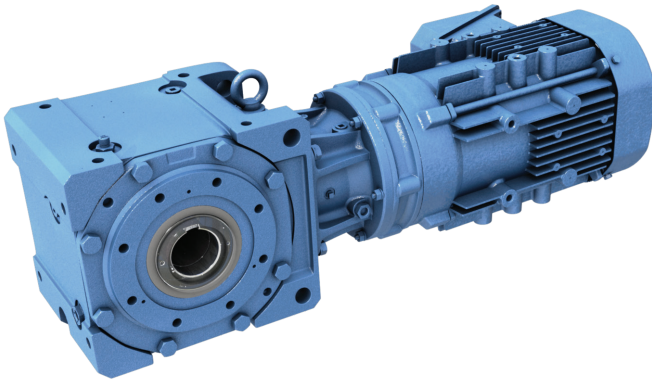

## Table of Contents

### 1. General Information

### 2. Gearmotors

- How to Select .....2.2
- Configure a Model Number (Nomenclature) .....2.4
- AGMA Load Classifications .....2.6
- Selection Tables.....2.9
  - 1/8 HP - 60 HP.....2.9
- Dimensions.....2.132
  - Single Reduction ..... 2.136
  - Single Reduction Y2 Mounting ..... 2.144
  - Double Reduction.....2.146
  - Double Reduction Y2 Mounting..... 2.162

### 3. Options

- Keyed Hollow Shaft .....3.2
- Solid Output Shaft .....3.3
- Output Flange/Foot Mounted .....3.4
- Shrink Disc .....3.5
- Torque Arm Turnbuckle Type .....3.8
- Torque Arm T-Type (Optional).....3.9
- Screw Conveyor Drive .....3.10
- Clear Oil Fill Cup .....3.11
- Shaft Diameter Availability.....3.13
- Industry Packages .....3.16

### 4. Technical Information

- Special Load Guidelines.....4.6
- Lubrication ..... 4.24
- Motor Data ..... 4.26
- Thermal Duty ..... 4.39
- Standard Wiring..... 4.40
- Brakemotor Characteristics ..... 4.42
- Warranty ..... 4.53

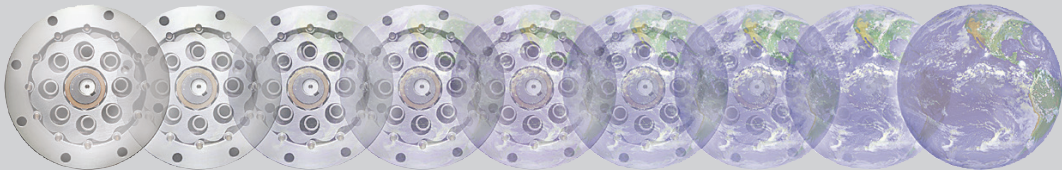



► Flexible configurations

- Output Shaft Options:  
Keyed Hollow  
Shrink Disc  
Solid Shaft  
(Keyless) Taper-Grip® Bushing
- Mounting Options:  
Flange  
Foot  
Shaft

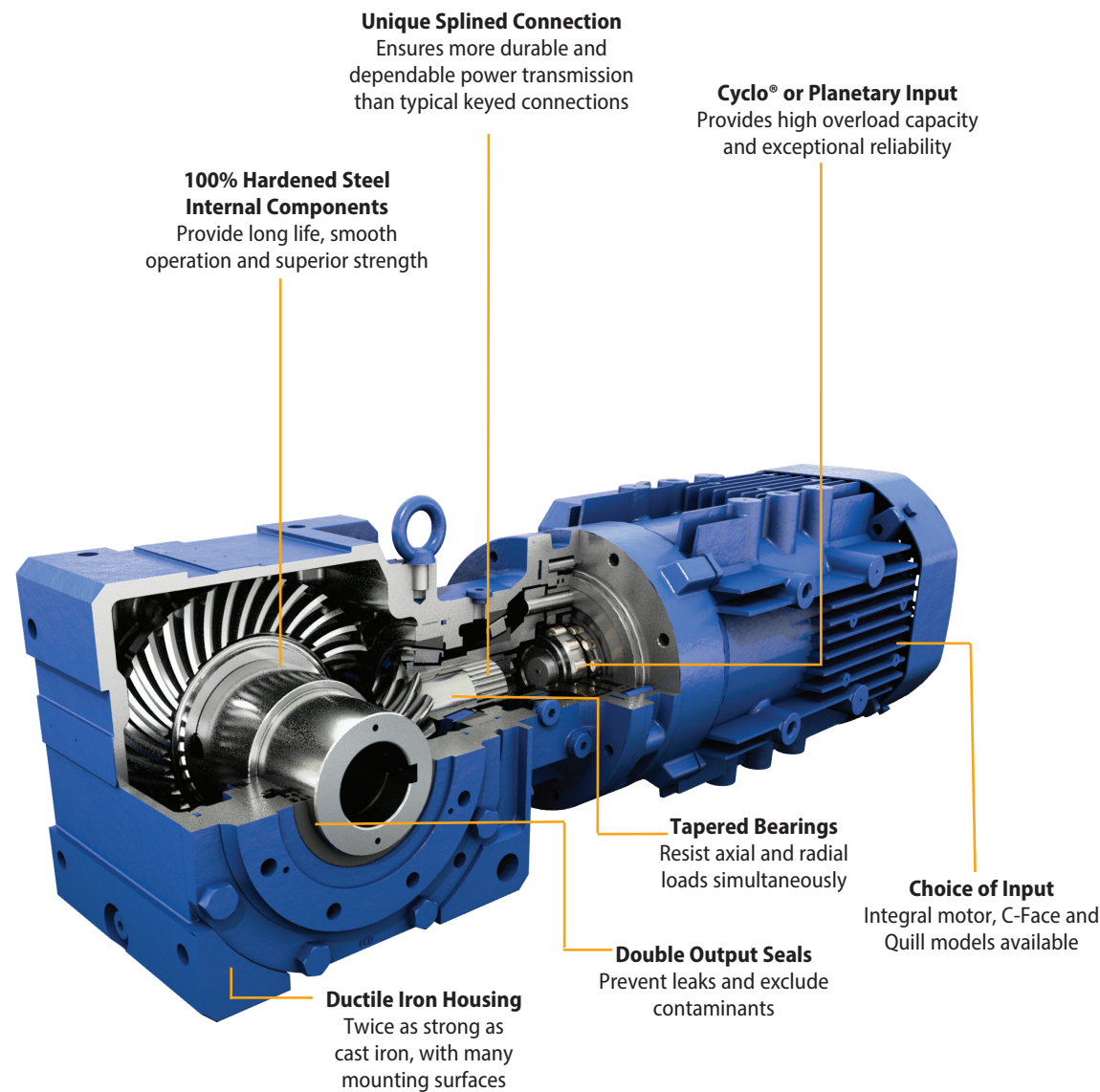

Product Description

The Cyclo® Bevel Buddy Box 4 (Cyclo BBB4) built by Sumitomo is a robust, state of the art mid-sized all steel family of speed reducers and gearmotors. Building on more than 75 years of successful Cyclo® experience in virtually every application and industry, the result is an extremely compact, efficient and reliable unit in a very power-dense package. The Cyclo® BBB4 is a unique combination of features that results in a highly reliable, efficient and durable gearbox. The all-steel internal construction, in conjunction with the Cyclo® or planetary gear inputs, and ductile iron housing provide unmatched ruggedness.

In addition, the full array of output mounting styles provides an amazing ability to customize the product to fit nearly any requirement. These options include solid shaft, hollow bore, and shrink disc.

Features & Benefits

- **100% Hardened Steel Rotating Components**  
~ Provide high efficiency, long life and exceptional reliability
- **Cycloidal or Planetary Input**  
~ Unmatched capability to handle overloads
- **Double Output Seals**  
~ Eight lip seals on every unit virtually eliminates the possibility of leaks
- **Dimensionally Interchangeable with BBB3**  
~ Simple, economical retrofits
- **Patented Taper-Grip® Bushing**  
~ Simple, keyless shaft mounting
- **Two year warranty**  
~ Not limited by hours of operation or duty cycles

General Specifications Summary

**Ratios:** 11:1 to 26,000:1 and greater  
**Torque Capacity:** 159,983 in. lbs. (17,400N-m)  
**HP:** 1/8 to 60 Hp (0.10 to 45 kW)  
**Mounting:** Hollow Shaft, Foot, Flange, Face  
**Input Options:** Integral Motor, C-Face, Quill, and Shovel Base  
**Motor Standards:** NEMA, IEC, JIS, UL, CSA, CE

► Popular Output Options

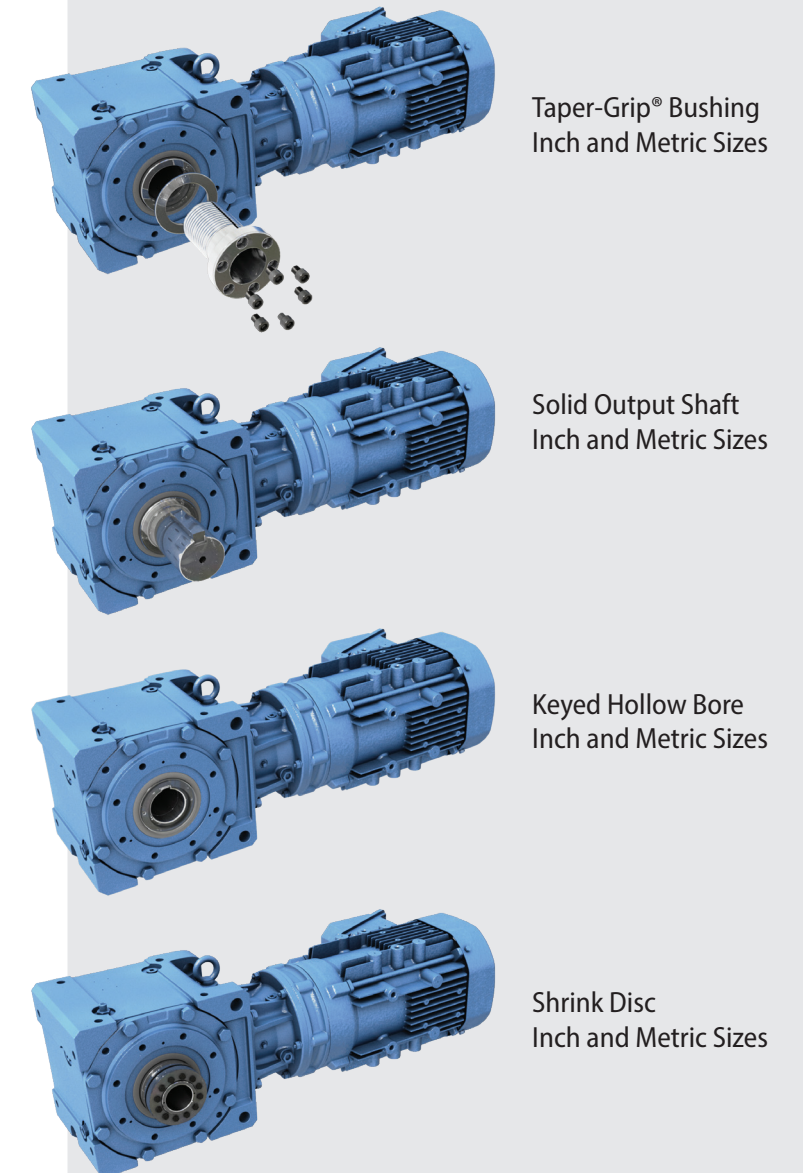

For additional BBB4 information, please visit [www.sumitomodrive.com](http://www.sumitomodrive.com)

More Compact, Space-Saving Design Than Typical Right-Angle Gearboxes

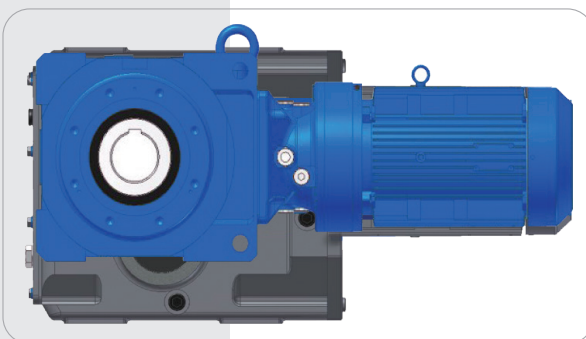

Simple, Single Reservoir Oil Lubrication for Easy Maintenance and Higher Performance

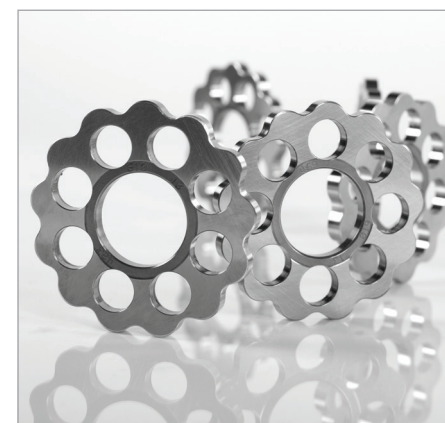
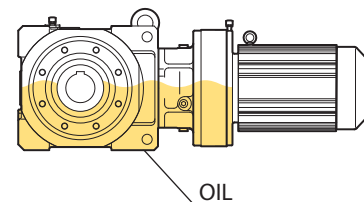

Cyclo® Quality and Reliability, Right Angle Design

- High performance steel input components deliver up to 94% efficiency
- Cycloidal technology offers reliable operation, long life and high shock load capacity







# Enhanced Performance (EP) Motors FAQs

### What efficiency level are these Enhanced Performance (EP) motors?

The EP motor (applies to 1HP and above) is a Premium efficiency class, or International Efficiency 3 (IE3) design. Our integral fractional (less than 1HP) motors are not EP and are classified as standard efficiency IE1 motors.

### What standards do these motors meet?

All Sumitomo motors are compliant with the Energy Policy and Conservation Act (EPAAct), as recently amended by the Department of Energy with a new ruling.

EP Sumitomo motors met the efficiency levels promoted by the Consortium for Energy Efficiency (CEE) and meet the Canadian efficiency levels specified by NRCan.

The IE3 efficiency ratings conform to both the IEC Standard 60034-30:2009 and eco-design directive 2005/32/EC.

### Will Sumitomo motors work with inverters?

All current EP motors feature corona resistant magnet wire that extends the life of the insulation and enables the motors to resist the voltage spikes common with IGBT variable frequency drives.

### What agency listings apply?

All EP motors in this product line are UL recognized, CSA certified and CE marked.

### Can the motor be nameplated to operate at 50 hertz?

The motor can be nameplated and will operate at 50 hertz, but depending on the export destination, it may not meet that country's energy efficiency requirements. For areas requiring IE3 performance at 50 hertz, like Asia and Europe, other 50 hertz specific versions can be provided. Conformance with energy efficiency requirements in destination country is the responsibility of the customer.

### Is the selection procedure the same as previous gearmotors?

Similar, the difference is restricted to applications with a large number of across the line starts and stops. Because the EP motors have more inertia and higher inrush current than previous integral motors, a supplemental service factor is applied to these applications using EP motors. The selection procedure for fractional HP units is unchanged.

### Are the brakes the same?

The brakes are the same direct acting, fast response types used previously. For motors 1 HP and above they are a new larger model that has been redesigned to match the new motor profiles. Because the EP motor inertia is significantly higher, it may be necessary to adjust external trigger points or limit switches. Since the brake assembly shapes are different, old and new kits are not interchangeable.

### What is the standard insulation system?

The motors continue with the Class F system, which limits the temperature rise to a Class B rise, where it bounds the allowable temperature rise to 80°C. It utilizes an insulation system capable of handling a 105°C rise to significantly extend insulation life.

### Are EP motors interchangeable with old AF-motors?

The new EP motors without brake have the same 10:1 constant torque speed range as the AF-motor. Motors are dimensionally and performance-wise different so VFD re-programming may be required. For EP brakemotor with use on VFDs, the applicable speed range may be limited. Please consult the factory for options for EP brakemotors.

### Will old motors continue to be available?

For motor powers 1 HP and above, EP motors have replaced the standard efficiency motors. (does not apply to fractional HP). 1HP+ Older motors do not meet the federally mandated efficiency requirements that went into effect on June 1, 2016. Non-compliant motors cannot be manufactured or imported into the United States.

### Should I be concerned if I am replacing an older motor with the new EP motor?

For most applications, the use of the new EP motor will result in a more efficient, cooler-running and energy-saving motor. However, for applications with certain performance constraints, you may need to review the impact of the following:

- larger dimension and weight
- larger moment of inertia
- higher starting current and torque.

If taking an old standard efficiency motor off a gearmotor and replacing it with the same HP new EP motor, the EP motor will bolt to the old gearmotor. The motor flange diameters, pilot diameters, bolt patterns and shaft diameters all match. Motor body dimensions and weight will change.

# Standard Specifications

	Standard Specifications	Standard Specifications with Built-In Brake		
<b>3 Phase Integral Motor</b>	Capacity Range:	1/8 ~ 60HP (0.1 ~ 45 kW), 4P	1/8 ~ 40HP (0.1 ~ 30 kW), 4P, FB Brake 37 ~ 45 kW (50 ~ 60HP), 4P, ESB Brake	
	Power Supply:	Motor Power: 230/460V, 60Hz, 3Phase 575V, 60Hz, 3Phase	Brake Power: 1/8 ~ 15HP (0.1 ~ 11kW): 230/460V, 60Hz, 3Ph 575V, 60Hz, 3Ph 20 ~ 40HP (15 ~ 30kW): 200 ~ 240V, 60Hz, 3Ph 380 ~ 480V 60Hz, 3Ph 575V, 60Hz, 3Ph	
	Motor Standard: Efficiency: Protection:	NEMA Premium Efficiency (IE3) (1 HP+) IP55	NEMA Premium Efficiency (IE3) (1 HP+) IP55 (1 ~ 15HP) IP54 (20 ~ 60HP)	
	Certification: Conduit Box: Inverter Operation:	CE Mark, UL Recognized, CSA Approval Diecast Aluminum, NPT Conduit Thread 10:1 Constant Torque Speed Range Insulation Meets NEMA MG1, Part 31	CE Mark, UL Recognized, CSA Approval Diecast Aluminum, NPT Conduit Thread 4:1 Constant Torque Speed Range or better. Insulation Meets NEMA MG1, Part 31	
	Enclosure: Motor Type: Frame Material:	Totally Enclosed Fan Cooled Type except 1/8HP is TENV Induction Motor, Squirrel Cage Rotor 1/8 ~ 20HP (0.1 ~ 15kW), 4P: diecast Al 25HP ~ 60HP (18.5 ~ 45kW), 4P: cast iron	Totally Enclosed Fan Cooled Type Induction Motor, Squirrel Cage Rotor 1/8 ~ 20HP (0.1 ~ 15kW), 4P: diecast Al 25HP ~ 60HP (18.5 ~ 45kW), 4P: cast iron	
	Bearings: Insulation:	Deep Groove, Ball Bearing, CM Clearance Class F with a Class B Rise	Deep Groove, Ball Bearing, CM Clearance Motor: Class F with a Class B Rise Brake: Class F	
	Time Rating:	Continuous	Continuous	
	<b>BBB4 Reducer</b>	Reduction:	Combination of Cyclo or Planetary input and right angle spiral bevel gear output	
		Lubrication:	In all mounting configurations except Y4, the Cyclo and Bevel portions are oil lubricated. For the Y4 mounting configuration, the Cyclo portion is grease lubricated and the bevel portion is oil lubricated	
		Seals:	Nitrile material, dual lipped, tandem output seals	
Material: Paint Color:		Rugged ductile cast iron housings in all sizes Blue, Munsell color number 6.5PB 3.6/8.2		
Bearings:		Tapered roller bearings on geared output of all sizes. Deep groove ball bearings on Cyclo input		
<b>Ambient Conditions</b>	Installation Location:	Indoor (Minimal dust and humidity)		
	Ambient Temperature:	14° ~ 104° F (-10° ~ 40° C)		
	Ambient Humidity:	Under 85%		
	Elevation:	Under 3300 feet (1000 meters)		
	Atmosphere:	Well ventilated location, free of corrosive gases, explosive gases, vapors, and dust		

# Mounting Positions

Note: 1. Mounting positions are shown with standard (Taper Grip Bushing) output option.  
2. The plane of reference represents the location of customer's equipment.

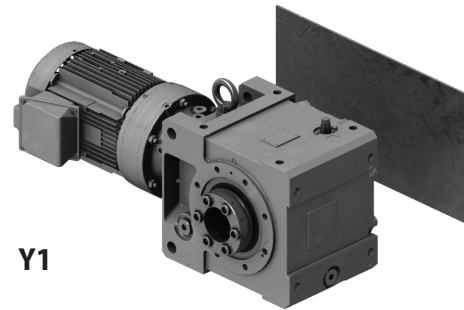

Y1

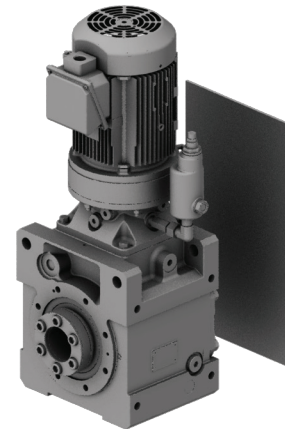

Y2

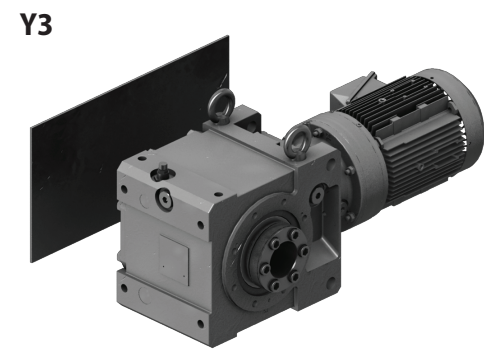

Y3

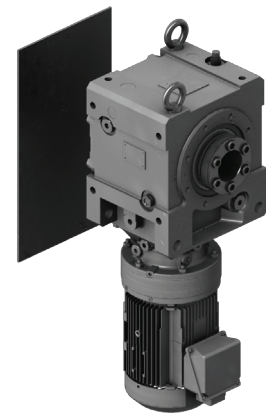

Y4

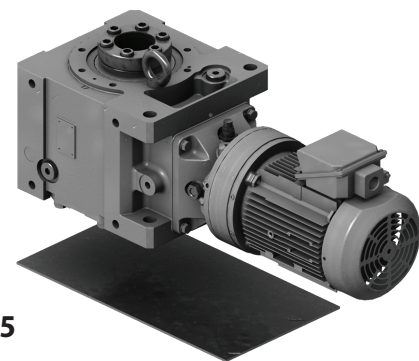

Y5

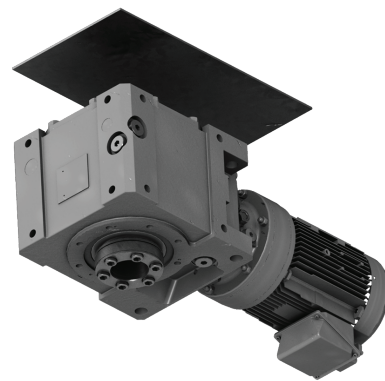

Y6

# Additional Mounting Positions

Figure 1.1 Keyed Hollow Output Bore - Output Flange Left<sup>[1]</sup>

LHY □ - □ $\square$ K - F1 - □	LHY □ - □ $\square$ K - F2 - □	LHY □ - □ $\square$ K - F3 - □
Ceiling 	Ceiling 	Ceiling 
Floor 	Floor 	Floor 
LHY □ - □ $\square$ K - F4 - □	LVY □ - □ $\square$ K - F5 - □	LVY □ - □ $\square$ K - F6 - □
Ceiling 	Ceiling 	Ceiling 
Floor 	Floor 	Floor 

Figure 1.2 Keyed Hollow Output Bore - Output Flange Right<sup>[1]</sup>

LHY □ - □ $\square$ K - G1 - □	LHY □ - □ $\square$ K - G2 - □	LHY □ - □ $\square$ K - G3 - □
Ceiling 	Ceiling 	Ceiling 
Floor 	Floor 	Floor 
LHY □ - □ $\square$ K - G4 - □	LVY □ - □ $\square$ K - G5 - □	LVY □ - □ $\square$ K - G6 - □
Ceiling 	Ceiling 	Ceiling 
Floor 	Floor 	Floor 

Figure 1.3 Solid Output Shaft (L) - Output Flange Left<sup>[1]</sup>

LHF □ - □ L $\square$ K - F1 - □	LHF □ - □ L $\square$ K - F2 - □	LHF □ - □ L $\square$ K - F3 - □
Ceiling 	Ceiling 	Ceiling 
Floor 	Floor 	Floor 
LHF □ - □ L $\square$ K - F4 - □	LVF □ - □ L $\square$ K - F5 - □	LWF □ - □ L $\square$ K - F6 - □
Ceiling 	Ceiling 	Ceiling 
Floor 	Floor 	Floor 

Note: [1] K = inch diameter shaft or keyed hollow bore in Model Number; blank = metric diameter shaft or keyed hollow bore in Model Number.  
Refer to page 2.4 for configure Model Number.



# Additional Mounting Positions continued

**Figure 1.4 Solid Output Shaft Right (R) - Output Flange Right**

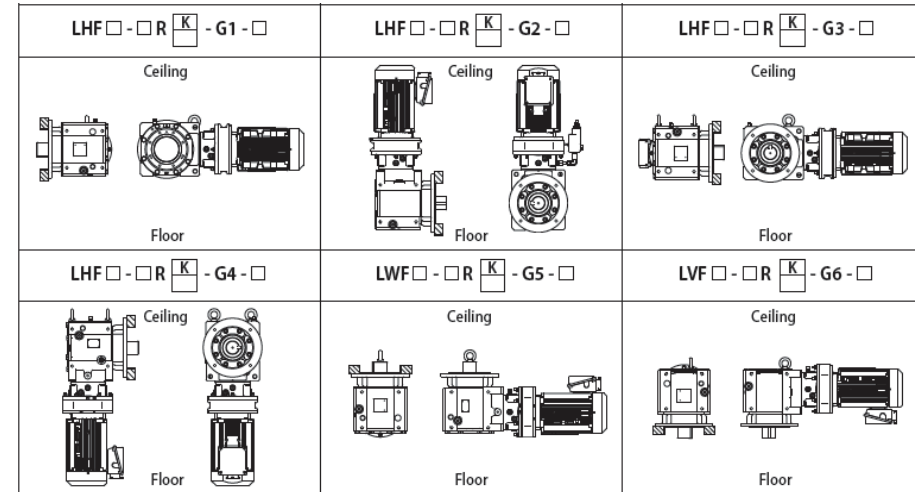

**Figure 1.5 Double Extended Solid Output Shaft (T) - Output Flange Left**

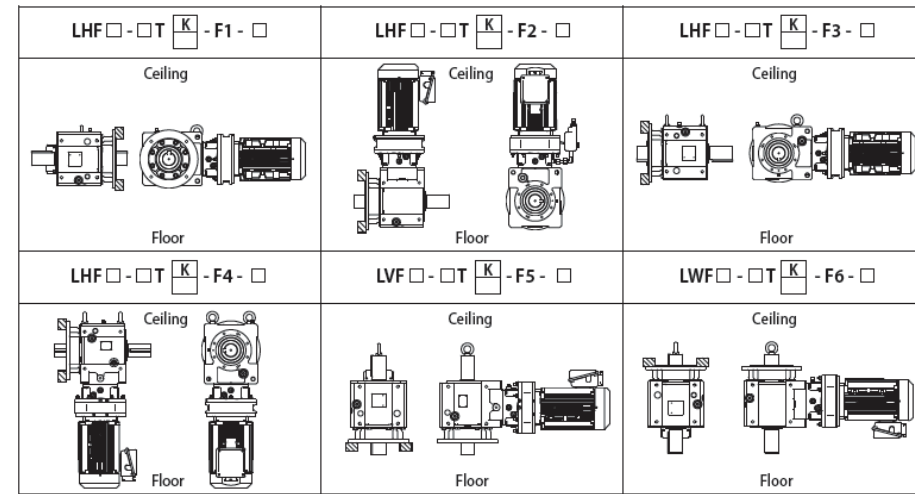

**Figure 1.6 Double Extended Solid Output Shaft (T) - Output Flange Right**

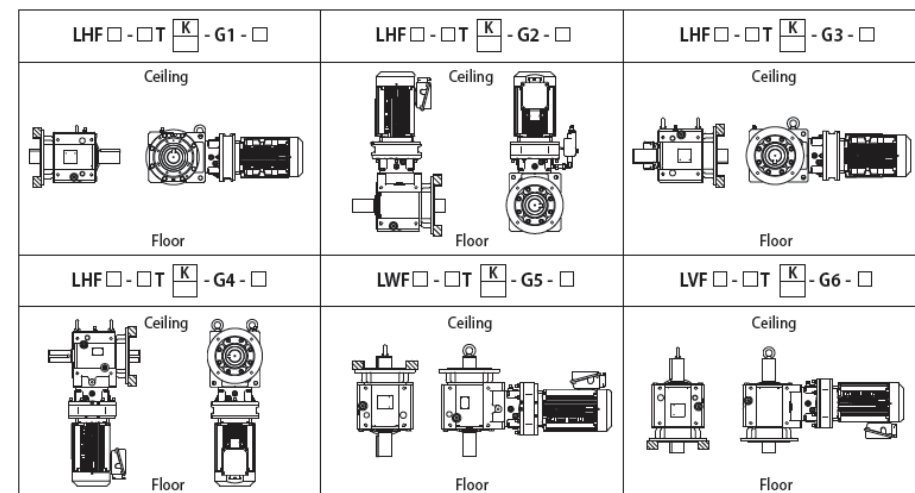

Notes: [1] K = inch diameter shaft or keyed hollow bore; blank = metric diameter shaft or keyed hollow bore.

# Additional Mounting Positions continued

**Figure 1.7 Solid Output Shaft Left (L) - Output Flange Right**

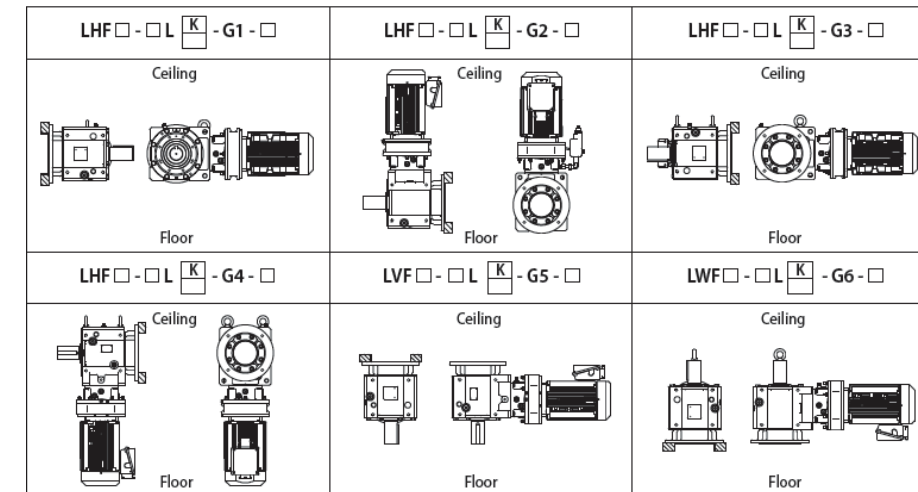

**Figure 1.8 Solid Output Shaft Right (R) - Output Flange Left**

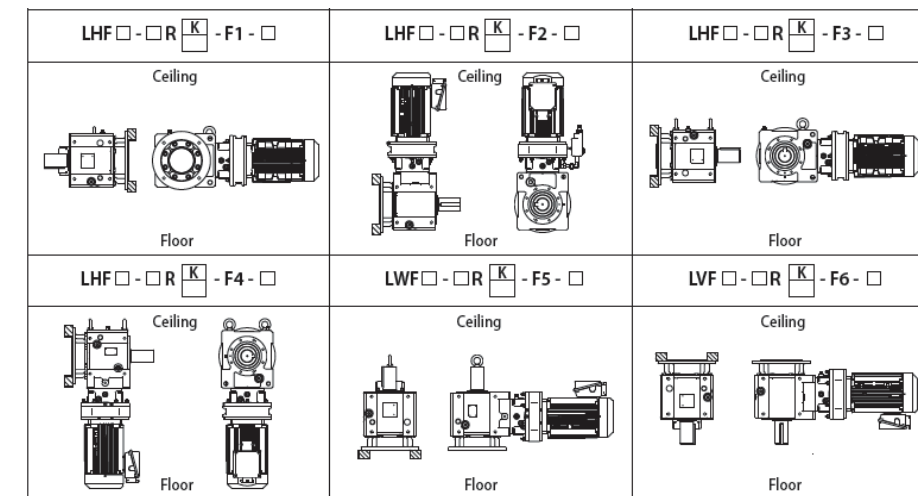

**Figure 1.9 Solid Output Shaft Left (L) - Mounting Foot Bottom**

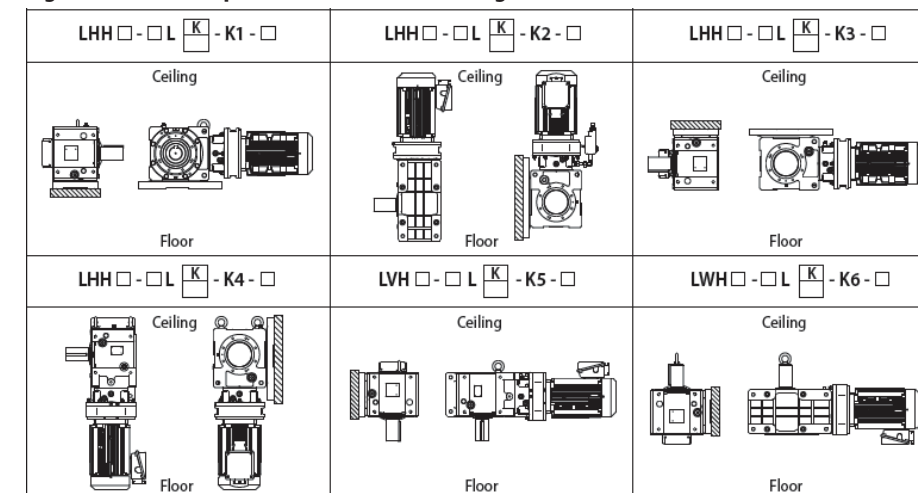

Notes: [1] K = inch diameter shaft or keyed hollow bore; blank = metric diameter shaft or keyed hollow bore.

# Additional Mounting Positions continued

Figure 1.10 Solid Output Shaft Right (R) - Mounting Foot Bottom

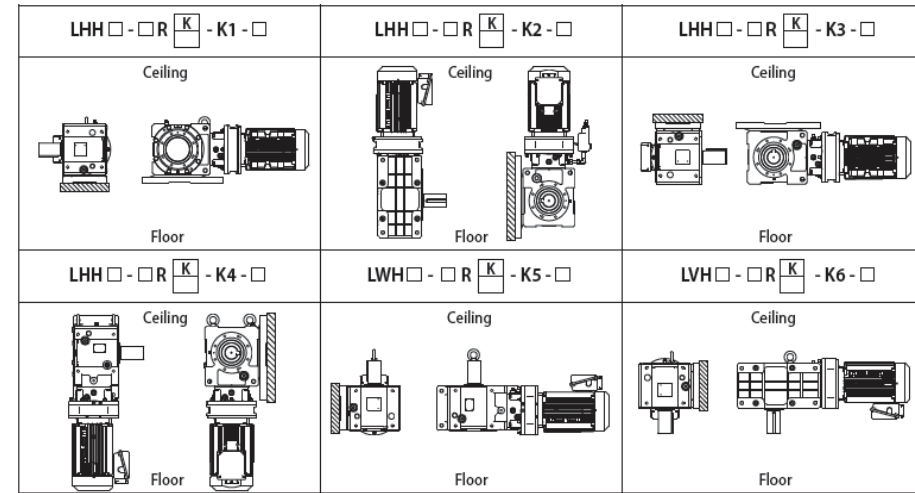

Figure 1.11 Double Extended Solid Output Shaft (T) - Mounting Foot Bottom

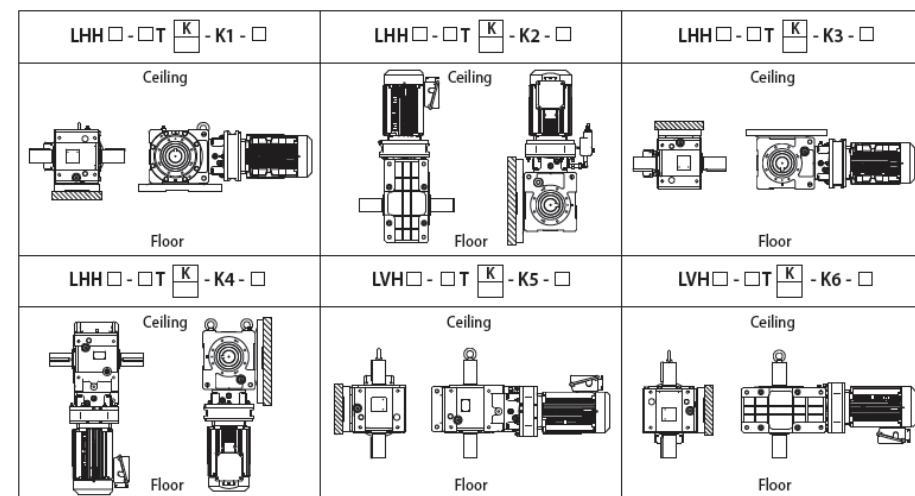
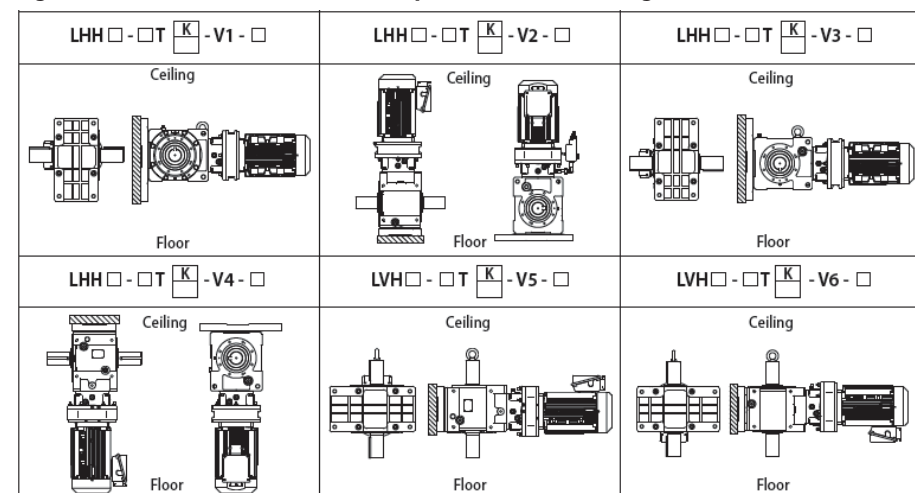

Figure 1.12 Double Extended Solid Output Shaft (T) - Mounting Foot Side



Notes: [1] K = inch diameter shaft or keyed hollow bore; blank = metric diameter shaft or keyed hollow bore.

# Additional Mounting Positions continued

Figure 1.13 Solid Output Shaft Left (L) - Mounting Foot Side

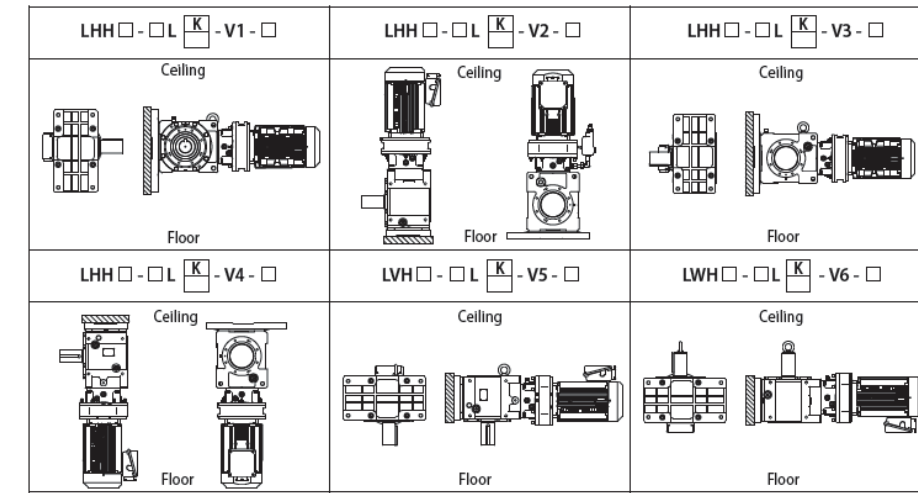

Figure 1.14 Solid Output Shaft Right (R) - Mounting Foot Side

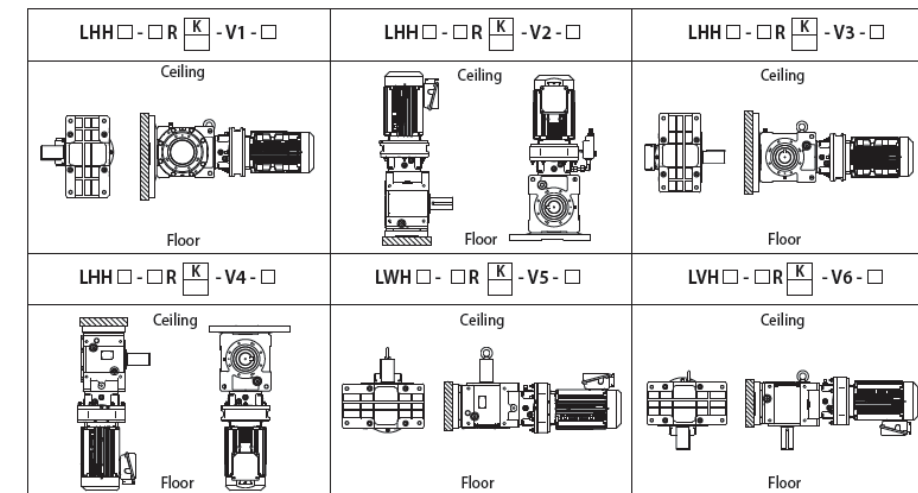
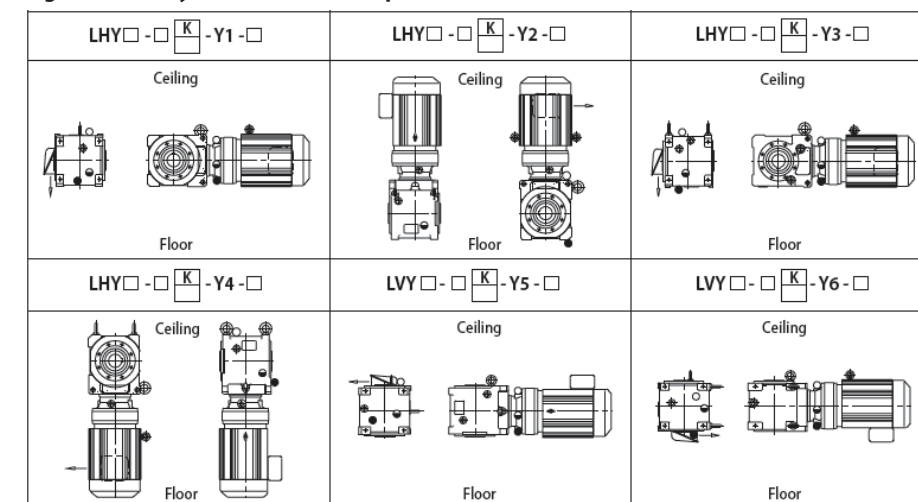

Figure 1.15 Keyed Hollow Bore Output Bore



Notes: [1] K = inch diameter shaft or keyed hollow bore; blank = metric diameter shaft or keyed hollow bore.

# Optional Ratios

Single Reduction												
Nominal Ratio	Overall	19	26	42	48	54	93	138	163	189	227	278
	Input	6	8	13	15	17	29	43	51	59	71	87
Exact Ratio	Overall	19.2	25.6	41.6	48	54.4	92.8	137.6	163.2	188.8	227.2	278.4
	Output	3.2										
	Input	6	8	13	15	17	29	43	51	59	71	87

Double Reduction															
Nominal Ratio	Overall	387	403	420	435	441	458	476	525	528	538	541	557	588	598
	Input	121	126	120	136	126	143	136	150	165	168	169	174	168	187
Exact Ratio	Overall	387.2	403.2	420.0	435.2	441.0	457.6	476.0	525.0	528.0	537.6	540.8	556.8	588.0	598.4
	Output	3.2	3.2	3.5	3.2	3.5	3.2	3.5	3.5	3.2	3.2	3.2	3.2	3.5	3.2
	Input	(11 x 11)	(21 x 6)	(15 x 8)	(17 x 8)	(21 x 6)	(13 x 11)	(17 x 8)	(25 x 6)	(15 x 11)	(21 x 8)	(13 x 13)	(29 x 6)	(21 x 8)	(17 x 11)
Nominal Ratio	Overall	609	624	640	655	672	707	720	739	774	788	812	816	826	874
	Input	174	195	200	187	210	221	225	231	221	225	232	255	258	273
Exact Ratio	Overall	609.0	624.0	640.0	654.5	672.0	707.2	720.0	739.2	773.5	787.5	812.0	816.0	825.6	873.6
	Output	3.5	3.2	3.2	3.5	3.2	3.2	3.2	3.2	3.5	3.5	3.5	3.2	3.2	3.2
	Input	(29 x 6)	(15 x 13)	(25 x 8)	(17 x 11)	(35 x 6)	(17 x 13)	(15 x 15)	(21 x 11)	(17 x 13)	(15 x 15)	(29 x 8)	(17 x 15)	(43 x 6)	(21 x 13)
Nominal Ratio	Overall	893	896	903	925	963	980	1008	1012	1021	1040	1071	1103	1138	1142
	Input	255	280	258	289	275	280	315	289	319	325	306	315	325	357
Exact Ratio	Overall	892.5	896.0	903.0	924.8	962.5	980.0	1008.0	1011.5	1020.8	1040.0	1071.0	1102.5	1137.5	1142.4
	Output	3.5	3.2	3.5	3.2	3.5	3.5	3.2	3.5	3.2	3.2	3.5	3.5	3.5	3.2
	Input	(17 x 15)	(35 x 8)	(43 x 6)	(17 x 17)	(25 x 11)	(35 x 8)	(21 x 15)	(17 x 17)	(29 x 11)	(25 x 13)	(51 x 6)	(21 x 15)	(25 x 13)	(21 x 17)
Nominal Ratio	Overall	1200	1204	1206	1232	1239	1250	1306	1313	1348	1360	1392	1411	1428	1456
	Input	375	344	377	385	354	357	408	375	385	425	435	441	408	455
Exact Ratio	Overall	1200.0	1204.0	1206.4	1232.0	1239.0	1249.5	1305.6	1312.5	1347.5	1360.0	1392.0	1411.2	1428.0	1456.0
	Output	3.2	3.5	3.2	3.2	3.5	3.5	3.2	3.5	3.5	3.2	3.2	3.2	3.5	3.2
	Input	(25 x 15)	(43 x 8)	(29 x 13)	(35 x 11)	(59 x 6)	(21 x 17)	(51 x 8)	(25 x 15)	(35 x 11)	(25 x 17)	(29 x 15)	(21 x 21)	(51 x 8)	(35 x 13)
Nominal Ratio	Overall	1488	1510	1514	1523	1544	1578	1593	1652	1670	1680	1726	1789	1795	1818
	Input	425	472	473	435	441	493	455	472	522	525	493	559	561	568
Exact Ratio	Overall	1487.5	1510.4	1513.6	1522.5	1543.5	1577.6	1592.5	1652.0	1670.4	1680.0	1725.5	1788.8	1795.2	1817.6
	Output	3.5	3.2	3.2	3.5	3.5	3.2	3.5	3.5	3.2	3.2	3.5	3.2	3.2	3.2
	Input	(25 x 17)	(59 x 8)	(43 x 11)	(29 x 15)	(21 x 21)	(29 x 17)	(35 x 13)	(59 x 8)	(87 x 6)	(35 x 15)	(29 x 17)	(43 x 13)	(51 x 11)	(71 x 8)
Nominal Ratio	Overall	1827	1838	1904	1949	1964	1988	2000	2064	2077	2083	2132	2188	2227	2258
	Input	522	525	595	609	561	568	625	645	649	595	609	625	696	645
Exact Ratio	Overall	1827.0	1837.5	1904.0	1948.8	1963.5	1988.0	2000.0	2064.0	2076.8	2082.5	2131.5	2187.5	2227.2	2257.5
	Output	3.5	3.5	3.2	3.2	3.5	3.5	3.2	3.2	3.2	3.5	3.5	3.5	3.2	3.5
	Input	(87 x 6)	(35 x 15)	(35 x 17)	(29 x 21)	(51 x 11)	(71 x 8)	(25 x 25)	(43 x 15)	(59 x 11)	(35 x 17)	(29 x 21)	(25 x 25)	(87 x 8)	(43 x 15)
Nominal Ratio	Overall	2320	2339	2352	2436	2448	2454	2499	2538	2573	2678	2685	2691	2734	2774
	Input	725	731	735	696	765	767	781	725	735	765	767	841	781	867
Exact Ratio	Overall	2320.0	2339.2	2352.0	2436.0	2448.0	2454.4	2499.2	2537.5	2572.5	2677.5	2684.5	2691.2	2733.5	2774.4
	Output	3.2	3.2	3.2	3.5	3.2	3.2	3.2	3.5	3.5	3.5	3.5	3.2	3.5	3.2
	Input	(29 x 25)	(43 x 17)	(35 x 21)	(87 x 8)	(51 x 15)	(59 x 13)	(71 x 11)	(29 x 25)	(35 x 21)	(51 x 15)	(59 x 13)	(29 x 29)	(71 x 11)	(51 x 17)
Nominal Ratio	Overall	2800	2832	2890	2954	3035	3062	3063	3098	3161	3210	3231	3248	3350	3408
	Input	875	885	903	923	867	957	875	885	903	1003	923	1015	957	1065
Exact Ratio	Overall	2800.0	2832.0	2889.6	2953.6	3034.5	3062.4	3062.5	3097.5	3160.5	3209.6	3230.5	3248.0	3349.5	3408.0
	Output	3.2	3.2	3.2	3.2	3.5	3.2	3.5	3.5	3.5	3.2	3.5	3.2	3.5	3.2
	Input	(35 x 25)	(59 x 15)	(43 x 21)	(71 x 13)	(51 x 17)	(87 x 11)	(35 x 25)	(59 x 15)	(43 x 21)	(59 x 17)	(71 x 13)	(35 x 29)	(87 x 11)	(71 x 15)
Nominal Ratio	Overall	3427	3440	3553	3619	3728	3749	3763	3862	3920	3965	3990	4080	4176	4225
	Input	1071	1075	1015	1131	1065	1071	1075	1207	1225	1239	1247	1275	1305	1207
Exact Ratio	Overall	3427.2	3440.0	3552.5	3619.2	3727.5	3748.5	3762.5	3862.4	3920.0	3964.8	3990.4	4080.0	4176.0	4224.5
	Output	3.2	3.2	3.5	3.2	3.5	3.5	3.5	3.2	3.2	3.2	3.2	3.2	3.2	3.5
	Input	(51 x 21)	(43 x 25)	(35 x 29)	(87 x 13)	(71 x 15)	(51 x 21)	(43 x 25)	(71 x 17)	(35 x 35)	(59 x 21)	(43 x 29)	(51 x 25)	(87 x 15)	(71 x 17)
Nominal Ratio	Overall	4288	4337	4463	4568	4720	4771	4816	5163	5219	5268	5475	5680	5712	5846
	Input	1225	1239	1275	1305	1475	1491	1505	1475	1491	1505	1711	1775	1785	1827
Exact Ratio	Overall	4287.5	4336.5	4462.5	4567.5	4720.0	4771.2	4816.0	5162.5	5218.5	5267.5	5475.2	5680.0	5712.0	5846.4
	Output	3.5	3.5	3.5	3.5	3.2	3.2	3.2	3.5	3.5	3.5	3.2	3.2	3.2	3.2
	Input	(35 x 35)	(59 x 21)	(51 x 25)	(87 x 15)	(59 x 25)	(71 x 21)	(43 x 35)	(59 x 25)	(71 x 21)	(43 x 35)	(59 x 29)	(71 x 25)	(51 x 35)	(87 x 21)
Nominal Ratio	Overall	5917	5989	6213	6248	6395	6589	6608	6960	7018	7207	7613	7676	7952	8074
	Input	1849	1711	1775	1785	1827	2059	2065	2175	2193	2059	2175	2193	2485	2523
Exact Ratio	Overall	5916.8	5988.5	6212.5	6247.5	6394.5	6588.8	6608.0	6960.0	7017.6	7206.5	7612.5	7675.5	7952.0	8073.6
	Output	3.2	3.5	3.5	3.5	3.5	3.2	3.2	3.2	3.2	3.5	3.5	3.5	3.2	3.2
	Input	(43 x 43)	(59 x 29)	(71 x 25)	(51 x 35)	(87 x 21)	(71 x 29)	(59 x 35)	(87 x 25)	(51 x 43)	(71 x 29)	(87 x 25)	(51 x 43)	(71 x 35)	(87 x 29)
Nominal Ratio	Overall	8118	8323	8698	8831	9104	9629	9744	9770	10532	10686	11139	11587	11971	
	Input	2537	2601	2485	2523	2601	3009	3045	3053	3009	3053	3481	3621	3741	
Exact Ratio	Overall	8118.4	8323.2	8697.5	8830.5	9103.5	9628.8	9744.0	9769.6	10531.5	10685.5	11139.2	11587.2	11971.2	
	Output	3.2	3.2	3.5	3.5	3.5	3.2	3.2	3.2	3.5	3.5	3.2	3.2	3.2	
	Input	(59 x 43)	(51 x 51)	(71 x 35)	(87 x 29)	(51 x 51)	(59 x 51)	(87 x 35)	(71 x 43)	(59 x 51)	(71 x 43)	(59 x 59)	(71 x 51)	(87 x 43)	
Nominal Ratio	Overall	12674	13094	13405	14198	14662	16131	16426	17644	19766	24221				
	Input	3621	3741	4189	4437	4189	5041	5133	5041	6177	7569				
Exact Ratio	Overall	12673.5	13093.5	13404.8	14198.4	14661.5	16131.2	16425.6	17643.5	19766.4	24220.8				
	Output	3.5	3.5	3.2	3.2	3.5	3.2	3.2	3.5	3.2	3.2				
	Input	(71 x 51)	(87 x 43)	(71 x 59)	(87 x 51)	(71 x 59)	(71 x 71)	(87 x 59)	(71 x 71)	(87 x 71)	(87 x 87)				



# 2

## How to Select

---

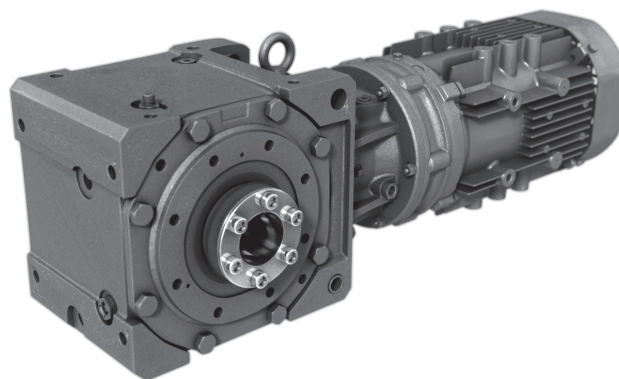

Cyclo® BBB4

How to  
Select

# How to select a Gearmotor



## Step 1: Collect data about your application

Before starting you need to know the:

- Application (e.g. Conveyor, Mixer, etc.)
- Hours of Operation per day
- Motor Power (HP or kW) and Speed (RPM)
- Desired Output Speed
- Mounting Position and Style
- Overhung or Thrust Loads
- Bore Dimensions, inch or metric
- Electrical Specifications

## Step 2: Choose a Mounting Position

Find the correct Mounting Position from the *Mounting Positions Drawing* on the right (larger images on page 1.8), additional positions on pages 1.9 to 1.13.

### Mounting Positions

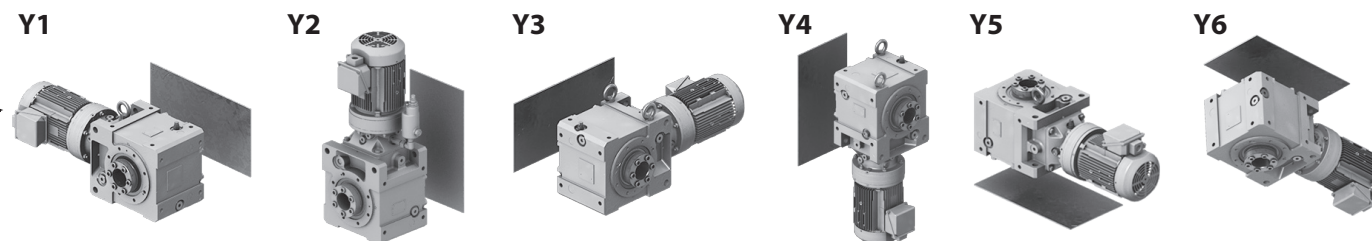

## Step 3: Select Frame Size

**3A:** Find the Load Classification of your application in the *AGMA Load Classification Tables* on pages 2.6 to 2.7.

**3B:** Go to the *Gearmotor Selection Table* (starts on page 2.9) that corresponds to the desired **Mounting Position** and **Motor Power**. Find the **Output Speed** closest to the desired output speed.

**3C:** Locate the **Service Class** in the *Gearmotor Selection Table* (starts on page 2.9) for your application and select the **Frame Size Selection** that matches the HP or kW, Output Speed, and Service Class.

## Step 4: Verify Dimensions

Use the Dimensions information starting on page 2.132 to verify that the selected Frame Size is appropriate.

## Step 5: If Selecting a Unit with a Taper Grip Bushing or Keyed Hollow Bore

Please specify desired bore size. Refer to page 3.10 for availability.

## Step 6: Choose Options

Please refer to Option section 3.1 and for additional available options please refer to our online Product Configurator at [www.sumitomodrive.com/configurator](http://www.sumitomodrive.com/configurator)

## Step 7: Configure a Model Number

Go to page 2.4 to configure a model number.

**Note:** You will use the information you gather from the procedure on this page to configure a model number.

### Select a Frame Size

- Mounting Position

Dimension Pages:  
 Single Reduction, 3.282 - 3.295  
 Single Reduction, AF-Motor 3.296 - 3.307  
 Single Reduction, Y2 3.308-3.309  
 Double Reduction 3.310- 3.327  
 Double Reduction, AF-Motor 3.328 - 3.341  
 Double Reduction, Y2 3.342 - 3.343

### Selection Tables

- Motor Power (HP or kW)

Frequency	Hz	50	60
Number of Poles	p		
Input Speed	RPM	1450	1750

**1HP (0.75kW)**

- Output Speed

- Service Class

- SELECTION

50Hz					60Hz					Selection		
Output Speed (RPM)	Output Torque in-lbs (N-m)	Service Factor SF	AGMA Class	Solid Shaft Overhung Load lbs (N)	Output Speed (RPM)	Output Torque in-lbs (N-m)	Service Factor SF	AGMA Class	Solid Shaft Overhung Load lbs (N)	Motor Power Code	Base Frame Size Ratio	VFD
24.4	2400 (271)	2.65	III	6050 (26900)	29.4	1990 (225)	2.65	III	6090 (27100)	1	4A100 60	•
21.6	2710 (306)	2.53	III	6020 (26800)	26.0	2250 (254)	2.57	III	6070 (27000)	1	4A100 67	•
19.7	2960 (335)	2.39	III	6000 (26700)	23.8	2450 (277)	2.57	III	6050 (26900)	1	4A100 74	•
18.1	3220 (364)	1.69	II	5960 (26500)	21.9	2670 (302)	1.69	II	6020 (26800)	1	4A100 80	•
		2.23	III	5960 (26500)			2.23	III	6020 (26800)	1	4A105 80	•
		2.55	III	5960 (26500)			2.55	III	6020 (26800)	1	4A110 80	•
		2.96	III	5960 (26500)			2.96	III	6020 (26800)	1	4A115 80	•
16.6	3530 (399)	1.69	II	5930 (26400)	20.0	2920 (330)	1.69	II	6000 (26700)	1	4A100 88	•
		2.23	III	5930 (26400)			2.23	III	6000 (26700)	1	4A105 88	•
		2.55	III	5930 (26400)			2.55	III	6000 (26700)	1	4A110 88	•
		2.96	III	5930 (26400)			2.96	III	6000 (26700)	1	4A115 88	•
14.3	4090 (462)	1.61	II	5850 (26000)	17.2	3390 (383)	1.61	II	5960 (26500)	1	4A100 102	•
		2.12	III	5850 (26000)			2.12	III	5960 (26500)	1	4A105 102	•
		2.53	III	5850 (26000)			2.53	III	5960 (26500)	1	4A110 102	•
		2.79	III	5850 (26000)			2.79	III	5960 (26500)	1	4A115 102	•

### STOCK BUSHING BORES

Size	Stock Bushing Bores Inch (mm)	Minimum Bores Inch (mm)
4A	1 1/16, 2 3/16 (50, 55)	1 1/16 (35)
4B	2 3/16, 2 7/16 (60, 65)	1 1/16 (45)
4C	2 7/16, 2 5/8 (65, 75)	2 3/16 (50)
4D	2 5/8, 3 1/16 (75, 85)	2 7/16 (60)
4E	3 1/16, 3 1/8 (90, 100)	2 5/16 (75)
4F	3 5/16, 4 7/16, 4 1/2 (110, 120)	3 1/2 (90)

For special circumstances in selecting a **Frame Size** such as:

- Overhung Load
- Thrust Loads
- Radial Loads
- Shock Loading

Consult Technical Information Section 4.1.

**If Overhung Load is present, any Overhung Load must be checked against the capacity of the selection.**



# Configure a Model Number

### Output Shaft Orientation

Type	Code
Horizontal	H
Vertical	V
Vertical Up (Solid Shaft)	W

Note: V and H units have the same dimensions as H base units. V and W are only used for mounting positions \*F5, \*G5, \*K5, \*V5, \*Y5, \*F6, \*G6, \*K6, \*V6, \*Y6

### Mounting Style

Type	Code
Shaft Mount (Hollow Shaft) page 3.2	Y
Housing Mount (Solid Shaft) page 3.3	U
Flange (Solid Shaft) page 3.4	F
Foot (Solid Shaft) page 3.4	H

### Input Connection

Type of Input	Code
Gearmotor	M

### Modification

Type	Code
Unit built with special modifications	S
Shrink Disc	S
No special modifications applied	

### Motor Power

(applies only to 1750 RPM)

HP	kW	Code
1/8		01
1/4		02
1/3		03
1/2		05
3/4		08
1	(0.75)	1
1 1/2	(1.1)	1H
2	(1.5)	2
3	(2.2)	3
5	(3.7)	5
7 1/2	(5.5)	8
10	(7.5)	10
15	(11)	15
20	(15)	20
25	(18.5)	25
30	(22)	30
40	(30)	40
50	(37)	50
60	(45)	60

### Required to be added at end of model number when ordering:

- Motor specifications (230/460 VAC 60 Hz is supplied, unless otherwise specified)
- Taper Grip Bushing or Keyed Hollow Bore or Output Shaft or Shrink Disc diameter must be specified (refer to pages 3.11 to 3.13 for diameters), example on page 3.14
- Optional Industry Package SSC code, refer to page 3.14

Optional conduit box positions available, please reference pages 4.26 to 4.28 for details.

### Frame Size

Single Reduction Input			
4A100	4B125	4C170	4E175
4A105	4B140	4C175	4E180
4A110	4B145	4D160	4E185
4A115	4B160	4D165	4E190
4A120	4B165	4D170	4E195
4A125	4C140	4D175	4F180
4A140	4C145	4D180	4F185
4A145	4C160	4D185	4F190
4B120	4C165	4E170	4F195

Double Reduction Input			
4A10DA	4B16DA	4C17DC	4E17DC
4A12DA	4B16DB	4D16DA	4E18DA
4A12DB	4B16DC	4D16DB	4E18DB
4A14DA	4C14DA	4D16DC	4E19DA
4A14DB	4C14DB	4D17DA	4E19DB
4A14DC	4C14DC	4D17DB	4F18DA
4B12DA	4C16DA	4D17DC	4F18DB
4B12DB	4C16DB	4D18DA	4F19DA
4B14DA	4C16DC	4D18DB	4F19DB
4B14DB	4C17DA	4E17DA	
4B14DC	4C17DB	4E17DB	

### Driven Shaft Direction (Shafted Model Only)

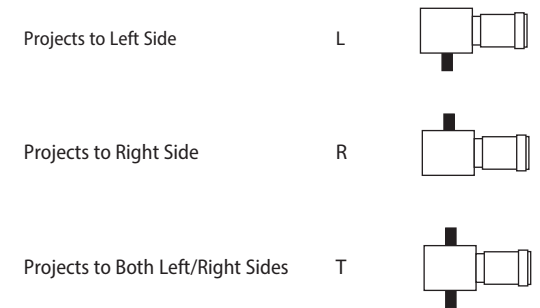

### Shaft Specifications

Input Shaft	OUTPUT SHAFT		Code
	Hollow	Solid	
mm	Key (mm)	mm	
Inch	Key (Inch)	Inch	K
mm	Taper Grip		M
Inch	Taper Grip		Y

### Nominal Ratios

BBB4 with Planetary Input Overall Nominal Ratio
11
13
14
16
18

### BBB4 with Cyclo Input

Single Reduction Input Overall Nominal Ratio	Double Reduction Input Overall Nominal Ratio
21	364
22	424
25	501
28	578
35	683
39	809
46	956
53	1117
60	1320
67	1656
74	1957
80	2272
88	2559
102	2944
112	3511
123	4365
151	5177
179	6472
207	7228
249	8880
305	10658
417	12184

### Mounting Positions

For selection refer to page 1.8 to 1.14

F1	G1	K1	V1	Y1
F2	G2	K2	V2	Y2
F3	G3	K3	V3	Y3
F4	G4	K4	V4	Y4
F5*	G5*	K5*	V5*	Y5*
F6*	G6*	K6*	V6*	Y6*

Note: \* = Only available for vertical output shaft orientations (LV or LW).

### AGMA Class

Class	Code
I	A
II	B
III	C

### Motor Specification

Specification	Code
AF Motor (Inverter Duty 1/8 HP to 3/4 HP)	AV
Inverter Ready Motor Premium Efficiency (1+HP), IE3	EP
*DC Motor	DV
*Low Backlash	LB
*Servo Motor	SV
Torque Limiter	TL

\*For Technical Information please contact customer service.

Note: When there are multiple suffices, sequence them alphabetically. Ex.: EPTL

### Brake

Code	
With Brake	B
No Brake	-

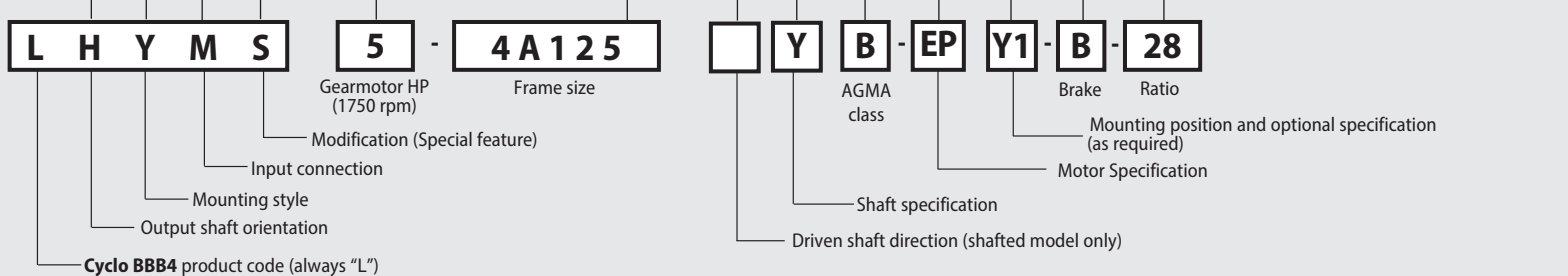

### Nomenclature Example:

**LHYMS5 - 4A125YB - EPY1-B - 28**

- L – Cyclo Bevel Buddybox
- H – Horizontal
- Y – Shaft Mount (Hollow Shaft)
- M – Integral Motor
- S – Modification (Special Feature)
- 5 – 5 HP (3 kW), 1750 RPM
- 4A125 – Frame Size
- Y – Taper-Grip® Bushing output
- B – AGMA Class II
- EP – Three-Phase Motor Premium Efficiency
- Y1 – Installation Position
- B – Brake
- 28 – Ratio





# Constant Torque Speed Ranges: Gearmotors

Table 2.8 Turn Down Ratio (CTSR) for Integral Motors in CONSTANT TORQUE Applications Powered by Variable Frequency Drives.

Motor Specification:	Motor without brake	Motor with Brake	AF Motor (AV suffix)	AF Motor with Brake (AV-B suffix)
1/8 HP (0.1 kW)	3:1	3:1	10:1	10:1
1/4 HP (0.2 kW)	3:1	3:1	10:1	10:1
1/3 HP (0.25 kW)	3:1	3:1	10:1	10:1
1/2 HP (0.4 kW)	3:1	3:1	10:1	10:1
3/4 HP (0.55 kW)	2:1	2:1	10:1	10:1
1 HP (0.75 kW)	10:1	10:1	10:1	10:1
1.5 HP (1.1 kW)	10:1	5:1	10:1	10:1
2 HP (1.5 kW)	10:1	4:1	10:1	10:1
3 HP (2.2 kW)	10:1	4:1	10:1	10:1
5 HP (3.7 kW)	10:1	4:1	10:1	10:1
7.5 HP (5.5 kW)	10:1	4:1	10:1	10:1
10 HP (7.5 kW)	10:1	6:1	10:1	10:1
15 HP (11 kW)	10:1	6:1	10:1	10:1
20 HP (15 kW)	10:1	10:1	10:1	10:1
25 HP (18.5 kW)	10:1	10:1	10:1	10:1
30 HP (22 kW)	10:1	10:1	10:1	10:1
40 HP (30 kW)	10:1	10:1	10:1	10:1
50 HP (37 kW)	10:1	10:1	10:1	10:1
60 HP (45 kW)	10:1	10:1	10:1	10:1

Cyclo® BBB4

CTSR Table

# Standard Mounting Selection Tables

**1/8 HP  
(0.1 kW)**

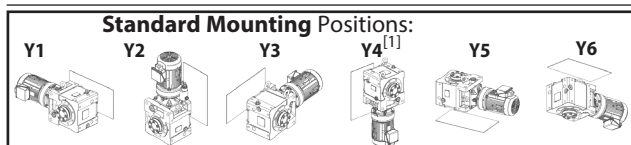

*Dimension Pages:*  
 Single Reduction 2.132-2.143  
 Single Reduction, Y2 2.144  
 Double Reduction 2.146-2.161  
 Double Reduction, Y2 2.162

Frequency	50 Hz	60 Hz
Input Speed	1450 RPM	1750 RPM
Number of Poles	4	

50Hz					60 Hz					Selection			VFD <sup>[2]</sup>				
Output Speed (RPM)	Output Torque		Service Factor		Solid Shaft Overhung Load		Output Speed (RPM)	Output Torque		Service Factor		Base					
	in-lbs	(N·m)	SF	AGMA Class	lbs	(N)		in-lbs	(N·m)	SF	AGMA Class	lbs		(N)	Motor Power Code	Frame Size	Ratio
3.48	2240	(253)	2.10	III	6060	(27000)	4.20	1850	(210)	2.10	III	6090	(27100)	01	<b>4A100</b>	417	(*)
			2.86	III	6060	(27000)				2.86	III	6090	(27100)	01	<b>4A105</b>	417	(*)
2.12	3480	(393)	2.60	III	5910	(26300)	2.56	2880	(326)	3.13	III	5990	(26600)	01	<b>4A10DA</b>	683	(a)
1.79	4120	(466)	2.19	III	5810	(25900)	2.16	3420	(386)	2.64	III	5920	(26300)	01	<b>4A10DA</b>	809	(a)
			2.77	III	5810	(25900)				3.34	III	5920	(26300)	01	<b>4A12DB</b>	809	(a)
1.52	4870	(551)	1.85	II	5670	(25200)	1.83	4040	(456)	2.24	III	5830	(25900)	01	<b>4A10DA</b>	956	(a)
			2.34	III	5670	(25200)				2.83	III	5830	(25900)	01	<b>4A12DB</b>	956	(a)
1.30	5690	(643)	1.59	II	5490	(24400)	1.57	4720	(533)	1.91	II	5700	(25400)	01	<b>4A10DA</b>	1117	(a)
			2.00	III	5490	(24400)				2.42	III	5700	(25400)	01	<b>4A12DB</b>	1117	(a)
1.10	6730	(760)	1.34	I	5200	(23100)	1.33	5580	(630)	1.62	II	5510	(24500)	01	<b>4A10DA</b>	1320	(a)
			1.70	II	5200	(23100)				2.05	III	5510	(24500)	01	<b>4A12DA</b>	1320	(a)
			2.82	III	9710	(43200)				3.40	III	9820	(43700)	01	<b>4B12DA</b>	1320	(a)
0.876	8440	(954)	1.07	I	4560	(20300)	1.06	7000	(791)	1.29	I	5110	(22700)	01	<b>4A10DA</b>	1656	(a)
			1.35	I	4560	(20300)				1.63	II	5110	(22700)	01	<b>4A12DA</b>	1656	(a)
			2.25	III	9510	(42300)				2.71	III	9680	(43100)	01	<b>4B12DA</b>	1656	(a)
			2.69	III	9510	(42300)				3.25	III	9680	(43100)	01	<b>4B14DA</b>	1656	(a)
0.741	9980	(1130)	0.91	-	3750	(16700)	0.894	8270	(934)	1.09	I	4640	(20600)	01	<b>4A10DA</b>	1957	(a)
			1.14	I	3750	(16700)				1.38	I	4640	(20600)	01	<b>4A12DA</b>	1957	(a)
			1.90	II	9290	(41300)				2.29	III	9540	(42400)	01	<b>4B12DA</b>	1957	(a)
			2.28	III	9290	(41300)				2.75	III	9540	(42400)	01	<b>4B14DA</b>	1957	(a)
0.638	11600	(1310)	0.99	-	2400	(10700)	0.770	9600	(1080)	1.19	I	3980	(17700)	01	<b>4A12DA</b>	2272	(a)
			1.64	II	9020	(40100)				1.98	II	9350	(41600)	01	<b>4B12DA</b>	2272	(a)
			1.96	II	9020	(40100)				2.37	III	9350	(41600)	01	<b>4B14DA</b>	2272	(a)
0.567	13000	(1470)	1.45	II	8720	(38800)	0.684	10800	(1220)	1.75	II	9160	(40700)	01	<b>4B12DA</b>	2559	(a)
			1.74	II	8720	(38800)				2.10	III	9160	(40700)	01	<b>4B14DA</b>	2559	(a)
0.493	15000	(1700)	1.26	I	8240	(36700)	0.595	12400	(1410)	1.53	II	8850	(39400)	01	<b>4B12DA</b>	2944	(a)
			2.75	III	15500	(68900)				2.86	III	15700	(69800)	01	<b>4C14DA</b>	2944	(a)
0.413	17900	(2020)	1.06	I	7350	(32700)	0.499	14800	(1680)	1.28	I	8290	(36900)	01	<b>4B12DA</b>	3511	(a)
			2.30	III	15200	(67600)				2.78	III	15500	(69000)	01	<b>4C14DA</b>	3511	(a)
0.332	22300	(2520)	0.85	-	5330	(23700)	0.401	18400	(2080)	1.03	I	7150	(31800)	01	<b>4B12DA</b>	4365	(a)
			1.85	II	14700	(65200)				2.24	III	15100	(67300)	01	<b>4C14DA</b>	4365	(a)

Cyclo® BBB4

Selection  
Tables

**Notes:** [1] For Y4 Double Reductions (4XXXDX) refer to the above table; for Y4 single reduction refer to tables on pages 2.91-2.130.

[2] Variable Frequency Drive (VFD) notes (see page 2.8 for Constant Torque Speed Ranges):

(\*) = AV motor required for selection (AV suffix required on model number, see page 2.4)

(a) = Both AV and non-AV motors can be used for selection.



# Standard Mounting Selection Tables

**1/4 HP  
(0.2 kW)**

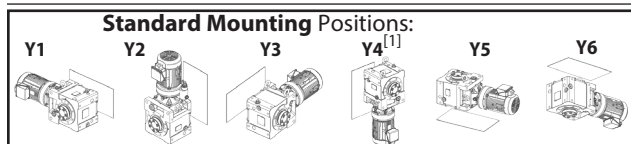

Dimension Pages:  
Single Reduction 2.132-2.143  
Single Reduction, Y2 2.144  
Double Reduction 2.146-2.161  
Double Reduction, Y2 2.162

Frequency	50 Hz	60 Hz
Input Speed	1450 RPM	1750 RPM
Number of Poles	4	

50Hz					60 Hz					Selection							
Output Speed (RPM)	Output Torque		Service Factor		Solid Shaft Overhung Load		Output Speed (RPM)	Output Torque		Service Factor		Solid Shaft Overhung Load		Base			VFD <sup>[2]</sup>
	in-lbs	(N·m)	SF	AGMA Class	lbs	(N)		in-lbs	(N·m)	SF	AGMA Class	lbs	(N)	Motor Power Code	Frame Size	Ratio	
8.12	1920	(217)	2.80	III	6090	(27100)	9.80	1590	(180)	2.80	III	6110	(27200)	02	<b>4A100</b>	179	(a)
7.02	2220	(251)	2.58	III	6070	(27000)	8.47	1840	(208)	2.58	III	6090	(27100)	02	<b>4A100</b>	207	(a)
5.84	2670	(302)	2.18	III	6030	(26800)	7.04	2210	(250)	2.18	III	6070	(27000)	02	<b>4A100</b>	249	(a)
			2.53	III	6030	(26800)				2.81	III	6070	(27000)	02	<b>4A105</b>	249	(a)
4.76	3270	(370)	2.17	III	5960	(26500)	5.75	2710	(306)	2.17	III	6020	(26800)	02	<b>4A100</b>	305	(a)
			2.51	III	5960	(26500)				2.83	III	6020	(26800)	02	<b>4A105</b>	305	(a)
3.98	3710	(420)	2.03	III	5880	(26100)	4.81	3080	(348)	2.03	III	5970	(26500)	02	<b>4A10DA</b>	364	(a)
3.48	4480	(506)	1.05	I	5790	(25800)	4.20	3710	(419)	1.05	I	5910	(26300)	02	<b>4A100</b>	417	(a)
			1.43	II	5790	(25800)				1.43	II	5910	(26300)	02	<b>4A105</b>	417	(a)
3.42	4320	(488)	2.03	III	5780	(25700)	4.13	3580	(404)	2.03	III	5900	(26200)	02	<b>4A10DA</b>	424	(a)
			2.64	III	5780	(25700)				3.19	III	5900	(26200)	02	<b>4A12DB</b>	424	(a)
2.90	5110	(577)	1.77	II	5620	(25000)	3.50	4230	(478)	2.03	III	5790	(25800)	02	<b>4A10DA</b>	501	(a)
			2.24	III	5620	(25000)				2.70	III	5790	(25800)	02	<b>4A12DB</b>	501	(a)
2.51	5890	(666)	1.53	II	5440	(24200)	3.03	4880	(552)	1.85	II	5670	(25200)	02	<b>4A10DA</b>	578	(a)
			1.94	II	5440	(24200)				2.34	III	5670	(25200)	02	<b>4A12DB</b>	578	(a)
			3.22	III	9790	(43600)				3.89	III	9870	(43900)	02	<b>4B12DB</b>	578	(a)
2.12	6960	(787)	1.30	I	5120	(22800)	2.56	5770	(652)	1.57	II	5470	(24300)	02	<b>4A10DA</b>	683	(a)
			1.64	II	5120	(22800)				1.98	II	5470	(24300)	02	<b>4A12DB</b>	683	(a)
			2.03	III	9690	(43100)				2.03	III	9800	(43600)	02	<b>4B12DA</b>	683	(a)
			2.73	III	9690	(43100)				3.29	III	9800	(43600)	02	<b>4B12DB</b>	683	(a)
1.79	8250	(932)	1.10	I	4650	(20700)	2.16	6830	(772)	1.32	I	5170	(23000)	02	<b>4A10DA</b>	809	(a)
			1.38	I	4650	(20700)				1.67	II	5170	(23000)	02	<b>4A12DB</b>	809	(a)
			2.03	III	9540	(42400)				2.03	III	9700	(43200)	02	<b>4B12DA</b>	809	(a)
			2.30	III	9540	(42400)				2.78	III	9700	(43200)	02	<b>4B12DB</b>	809	(a)
			2.76	III	9540	(42400)				3.33	III	9700	(43200)	02	<b>4B14DB</b>	809	(a)
1.52	9750	(1100)	0.93	-	3890	(17300)	1.83	8080	(913)	1.12	I	4720	(21000)	02	<b>4A10DA</b>	956	(a)
			1.17	I	3890	(17300)				1.41	II	4720	(21000)	02	<b>4A12DB</b>	956	(a)
			1.95	II	9330	(41500)				2.35	III	9560	(42500)	02	<b>4B12DB</b>	956	(a)
			2.33	III	9330	(41500)				2.82	III	9560	(42500)	02	<b>4B14DB</b>	956	(a)
1.30	11400	(1290)	1.00	I	2610	(11600)	1.57	9440	(1070)	1.21	I	4070	(18100)	02	<b>4A12DB</b>	1117	(a)
			1.67	II	9050	(40300)				2.01	III	9380	(41700)	02	<b>4B12DB</b>	1117	(a)
			2.00	III	9050	(40300)				2.41	III	9380	(41700)	02	<b>4B14DB</b>	1117	(a)
1.10	13500	(1520)	1.41	II	8630	(38400)	1.33	11200	(1260)	1.70	II	9100	(40500)	02	<b>4B12DA</b>	1320	(a)
			1.69	II	8630	(38400)				2.04	III	9100	(40500)	02	<b>4B14DB</b>	1320	(a)

Notes: [1] For Y4 Double Reductions (4XXXDX) refer to the above table; for Y4 single reduction refer to tables on pages 2.91-2.130.

[2] Variable Frequency Drive (VFD) notes (see page 2.8 for Constant Torque Speed Ranges):

(a) = Both AV and non-AV motors can be used for selection.

# Standard Mounting Selection Tables

**1/4 HP  
(0.2 kW)**

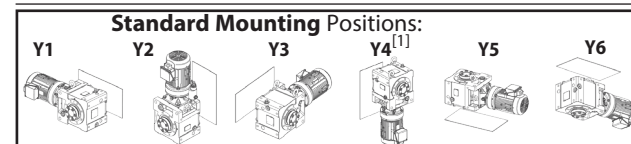

Dimension Pages:  
Single Reduction 2.132-2.143  
Single Reduction, Y2 2.144  
Double Reduction 2.146-2.161  
Double Reduction, Y2 2.162

Frequency	50 Hz	60 Hz
Input Speed	1450 RPM	1750 RPM
Number of Poles	4	

50Hz					60 Hz					Selection							
Output Speed (RPM)	Output Torque		Service Factor		Solid Shaft Overhung Load		Output Speed (RPM)	Output Torque		Service Factor		Solid Shaft Overhung Load		Base			VFD <sup>[2]</sup>
	in-lbs	(N·m)	SF	AGMA Class	lbs	(N)		in-lbs	(N·m)	SF	AGMA Class	lbs	(N)	Motor Power Code	Frame Size	Ratio	
0.876	16900	(1910)	1.12	I	7690	(34200)	1.06	14000	(1580)	1.36	I	8500	(37800)	02	<b>4B12DA</b>	1656	(a)
			1.35	I	7690	(34200)				1.63	II	8500	(37800)	02	<b>4B14DB</b>	1656	(a)
			2.03	III	15300	(68100)				2.03	III	15600	(69300)	02	<b>4C14DA</b>	1656	(a)
			2.44	III	15300	(68100)				2.95	III	15600	(69300)	02	<b>4C14DB</b>	1656	(a)
			2.69	III	15300	(68100)				3.25	III	15600	(69300)	02	<b>4C16DA</b>	1656	(a)
0.741	20000	(2260)	0.95	-	6530	(29000)	0.894	16500	(1870)	1.15	I	7800	(34700)	02	<b>4B12DA</b>	1957	(a)
			1.14	I	6530	(29000)				1.38	I	7800	(34700)	02	<b>4B14DB</b>	1957	(a)
			2.07	III	15000	(66600)				2.50	III	15300	(68200)	02	<b>4C14DB</b>	1957	(a)
			2.28	III	15000	(66600)				2.75	III	15300	(68200)	02	<b>4C16DA</b>	1957	(a)
0.638	23200	(2620)	0.98	-	4730	(21000)	0.770	19200	(2170)	1.18	I	6850	(30500)	02	<b>4B14DB</b>	2272	(a)
			1.78	II	14500	(64600)				2.15	III	15100	(67000)	02	<b>4C14DB</b>	2272	(a)
			1.96	II	14500	(64600)				2.37	III	15100	(67000)	02	<b>4C16DA</b>	2272	(a)
			2.73	III	21300	(94700)				3.29	III	21500	(95900)	02	<b>4D16DA</b>	2272	(a)
0.567	26100	(2950)	0.87	-	1100	(4890)	0.684	21600	(2440)	1.05	I	5700	(25400)	02	<b>4B14DA</b>	2559	(a)
			1.58	II	14100	(62600)				1.91	II	14700	(65600)	02	<b>4C14DA</b>	2559	(a)
			1.74	II	14100	(62600)				2.10	III	14700	(65600)	02	<b>4C16DA</b>	2559	(a)
			2.42	III	21100	(93700)				2.92	III	21400	(95200)	02	<b>4D16DA</b>	2559	(a)
			2.96	III	21100	(93700)				3.57	III	21400	(95200)	02	<b>4D17DA</b>	2559	(a)
0.493	30000	(3390)	1.37	I	13300	(59300)	0.595	24900	(2810)	1.66	II	14300	(63500)	02	<b>4C14DB</b>	2944	(a)
			2.11	III	20700	(92100)				2.54	III	21200	(94100)	02	<b>4D16DA</b>	2944	(a)
0.413	35800	(4050)	1.15	I	11900	(53100)	0.499	29700	(3350)	1.39	I	13400	(59600)	02	<b>4C14DA</b>	3511	(a)
			1.77	II	20100	(89300)				2.13	III	20700	(92200)	02	<b>4D16DA</b>	3511	(a)
			2.16	III	20100	(89300)				2.60	III	20700	(92200)	02	<b>4D17DA</b>	3511	(a)
			2.65	III	22000	(97800)				3.20	III	22300	(99200)	02	<b>4E17DA</b>	3511	(a)
0.332	44500	(5030)	0.93	-	8830	(39300)	0.401	36900	(4170)	1.12	I	11600	(51700)	02	<b>4C14DA</b>	4365	(a)
			1.73	II	18900	(84000)				2.09	III	19900	(88700)	02	<b>4D17DA</b>	4365	(a)
			2.13	III	21500	(95900)				2.57	III	21900	(97600)	02	<b>4E17DA</b>	4365	(a)
0.280	52800	(5970)	1.80	II	21100	(94000)	0.338	43800	(4940)	2.17	III	21600	(96000)	02	<b>4E17DA</b>	5177	(a)
0.201	73700	(8330)	0.86	-	11200	(49700)	0.242	61100	(6900)	1.04	I	15500	(68800)	02	<b>4D16DA</b>	7228	(a)
0.136	109000	(12300)	0.87	-	15100	(67000)	0.164	90100	(10200)	1.05	I	19200	(85600)	02	<b>4E17DA</b>	10658	(a)

Notes: [1] For Y4 Double Reductions (4XXXDX) refer to the above table; for Y4 single reduction refer to tables on pages 2.91-2.130.

[2] Variable Frequency Drive (VFD) notes (see page 2.8 for Constant Torque Speed Ranges):

(a) = Both AV and non-AV motors can be used for selection.

# Standard Mounting Selection Tables

**1/3 HP**  
(0.25 kW)

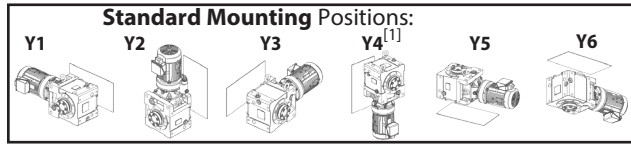

Dimension Pages:  
Single Reduction 2.132-2.143  
Single Reduction, Y2 2.144  
Double Reduction 2.146-2.161  
Double Reduction, Y2 2.162

Frequency	50 Hz	60 Hz
Input Speed	1450 RPM	1750 RPM
Number of Poles	4	

50Hz					60 Hz					Selection							
Output Speed (RPM)	Output Torque		Service Factor		Solid Shaft Overhung Load		Output Speed (RPM)	Output Torque		Service Factor		Solid Shaft Overhung Load		Base			VFD <sup>[2]</sup>
	in-lbs	(N·m)	SF	AGMA Class	lbs	(N)		in-lbs	(N·m)	SF	AGMA Class	lbs	(N)	Motor Power Code	Frame Size	Ratio	
8.12	2400	(271)	2.24	III	6050	(26900)	9.80	1990	(225)	2.24	III	6080	(27100)	03	<b>4A100</b>	179	(a)
7.02	2770	(313)	2.06	III	6020	(26800)	8.47	2300	(260)	2.06	III	6060	(27000)	03	<b>4A100</b>	207	(a)
			2.72	III	6020	(26800)				2.83	III	6060	(27000)	03	<b>4A105</b>	207	(a)
			1.74	II	5950	(26500)				1.74	II	6020	(26800)	03	<b>4A100</b>	249	(a)
5.84	3340	(377)	2.02	III	5950	(26500)	7.04	2770	(313)	2.24	III	6020	(26800)	03	<b>4A105</b>	249	(a)
			2.68	III	5950	(26500)				2.68	III	6020	(26800)	03	<b>4A110</b>	249	(*)
			1.73	II	5850	(26000)				1.73	II	5950	(26500)	03	<b>4A100</b>	305	(a)
4.76	4090	(462)	2.01	III	5850	(26000)	5.75	3390	(383)	2.26	III	5950	(26500)	03	<b>4A105</b>	305	(a)
			2.64	III	5850	(26000)				2.64	III	5950	(26500)	03	<b>4A110</b>	305	(*)
			2.79	III	5850	(26000)				2.79	III	5950	(26500)	03	<b>4A115</b>	305	(*)
			1.63	II	5720	(25400)				1.63	II	5860	(26100)	03	<b>4A10DA</b>	364	(a)
3.98	4640	(524)	2.46	III	5720	(25400)	4.81	3850	(435)	2.97	III	5860	(26100)	03	<b>4A12DB</b>	364	(a)
			1.14	I	5580	(24800)				1.14	I	5760	(25600)	03	<b>4A105</b>	417	(a)
3.48	5600	(632)	1.14	I	5580	(24800)	4.20	4640	(524)	1.14	I	5760	(25600)	03	<b>4A105</b>	417	(a)
3.42	5400	(610)	1.63	II	5560	(24700)	4.13	4470	(506)	1.63	II	5750	(25600)	03	<b>4A10DA</b>	424	(a)
2.90	6380	(721)	2.11	III	5560	(24700)	3.50	5290	(597)	2.55	III	5750	(25600)	03	<b>4A12DB</b>	424	(a)
			1.42	II	5300	(23600)				1.63	II	5580	(24800)	03	<b>4A10DA</b>	501	(a)
			1.79	II	5300	(23600)				2.16	III	5580	(24800)	03	<b>4A12DB</b>	501	(a)
2.51	7360	(832)	2.97	III	9750	(43400)	3.59	9840	(43800)	3.59	III	9840	(43800)	03	<b>4B12DB</b>	501	(a)
			1.23	I	4990	(22200)				1.48	II	5380	(23900)	03	<b>4A10DA</b>	578	(a)
			1.55	II	4990	(22200)				1.87	II	5380	(23900)	03	<b>4A12DB</b>	578	(a)
2.12	8700	(983)	2.58	III	9640	(42900)	3.03	6100	(689)	3.11	III	9770	(43500)	03	<b>4B12DB</b>	578	(a)
			1.04	I	4440	(19800)				1.25	I	5040	(22400)	03	<b>4A10DA</b>	683	(a)
			1.31	I	4440	(19800)				1.58	II	5040	(22400)	03	<b>4A12DB</b>	683	(a)
			1.63	II	9480	(42200)				1.63	II	9660	(43000)	03	<b>4B12DA</b>	683	(a)
			2.18	III	9480	(42200)				2.63	III	9660	(43000)	03	<b>4B12DB</b>	683	(a)
1.79	10300	(1160)	2.61	III	9480	(42200)	2.16	8540	(965)	3.15	III	9660	(43000)	03	<b>4B14DB</b>	683	(a)
			0.88	-	3530	(15700)				1.06	I	4520	(20100)	03	<b>4A10DA</b>	809	(a)
			1.11	I	3530	(15700)				1.34	I	4520	(20100)	03	<b>4A12DB</b>	809	(a)
1.52	12200	(1380)	1.63	II	9240	(41100)	1.83	10100	(1140)	1.63	II	9500	(42300)	03	<b>4B12DA</b>	809	(a)
			1.84	II	9240	(41100)				2.22	III	9500	(42300)	03	<b>4B12DB</b>	809	(a)
			2.21	III	9240	(41100)				2.66	III	9500	(42300)	03	<b>4B14DB</b>	809	(a)
			0.94	-	1530	(6830)				1.13	I	3670	(16300)	03	<b>4A12DB</b>	956	(a)
1.30	14200	(1610)	1.56	II	8900	(39600)	1.57	11800	(1330)	1.88	II	9280	(41300)	03	<b>4B12DB</b>	956	(a)
			1.87	II	8900	(39600)				2.25	III	9280	(41300)	03	<b>4B14DB</b>	956	(a)
			1.33	I	8440	(37600)				1.61	II	8980	(39900)	03	<b>4B12DB</b>	1117	(a)
0.876	21100	(2390)	1.60	II	8440	(37600)	1.93	8980	(39900)	1.93	II	8980	(39900)	03	<b>4B14DB</b>	1117	(a)
			2.90	III	15600	(69200)				3.50	III	15700	(70000)	03	<b>4C14DB</b>	1117	(a)

Notes: [1] For Y4 Double Reductions (4XXXDX) refer to the above table; for Y4 single reduction refer to tables on pages 2.91-2.130.

[2] Variable Frequency Drive (VFD) notes (see page 2.8 for Constant Torque Speed Ranges):

(\*) = AV motor required for selection (AV suffix required on model number, see page 2.4)

(a) = Both AV and non-AV motors can be used for selection.

# Standard Mounting Selection Tables

**1/3 HP**  
(0.25 kW)

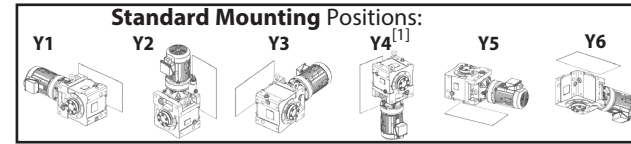

Dimension Pages:  
Single Reduction 2.132-2.143  
Single Reduction, Y2 2.144  
Double Reduction 2.146-2.161  
Double Reduction, Y2 2.162

Frequency	50 Hz	60 Hz
Input Speed	1450 RPM	1750 RPM
Number of Poles	4	

50Hz					60 Hz					Selection							
Output Speed (RPM)	Output Torque		Service Factor		Solid Shaft Overhung Load		Output Speed (RPM)	Output Torque		Service Factor		Solid Shaft Overhung Load		Base			VFD <sup>[2]</sup>
	in-lbs	(N·m)	SF	AGMA Class	lbs	(N)		in-lbs	(N·m)	SF	AGMA Class	lbs	(N)	Motor Power Code	Frame Size	Ratio	
1.10	16800	(1900)	1.13	I	7710	(34300)	1.33	13900	(1580)	1.36	I	8510	(37900)	03	<b>4B12DA</b>	1320	(a)
0.876	21100	(2390)	1.35	I	7710	(34300)	1.06	17500	(1980)	1.63	II	8510	(37900)	03	<b>4B14DB</b>	1320	(a)
			2.45	III	15300	(68100)				2.96	III	15600	(69300)	03	<b>4C14DB</b>	1320	(a)
			2.70	III	15300	(68100)				3.26	III	15600	(69300)	03	<b>4C16DA</b>	1320	(a)
			0.90	-	5980	(26600)				1.08	I	7490	(33300)	03	<b>4B12DA</b>	1656	(a)
0.741	24900	(2820)	1.08	I	5980	(26600)	0.894	20700	(2340)	1.30	I	7490	(33300)	03	<b>4B14DB</b>	1656	(a)
			1.63	II	14800	(65900)				1.63	II	15200	(67800)	03	<b>4C14DA</b>	1656	(a)
			1.95	II	14800	(65900)				2.36	III	15200	(67800)	03	<b>4C14DB</b>	1656	(a)
			2.16	III	14800	(65900)				2.60	III	15200	(67800)	03	<b>4C16DA</b>	1656	(a)
			3.00	III	21400	(95300)				3.62	III	21600	(96300)	03	<b>4D16DA</b>	1656	(a)
0.638	29000	(3270)	0.91	-	3130	(13900)	0.770	24000	(2710)	1.10	I	6200	(27600)	03	<b>4B14DB</b>	1957	(a)
			1.65	II	14300	(63400)				2.00	III	14900	(66200)	03	<b>4C14DB</b>	1957	(a)
			1.82	II	14300	(63400)				2.20	III	14900	(66200)	03	<b>4C16DA</b>	1957	(a)
			2.54	III	21100	(94100)				3.06	III	21500	(95400)	03	<b>4D16DA</b>	1957	(a)
0.567	32600	(3690)	1.42	II	13500	(60200)	0.684	27000	(3050)	1.72	II	14400	(64100)	03	<b>4C14DB</b>	2272	(a)
			1.57	II	13500	(60200)				1.90	II	14400	(64100)	03	<b>4C16DA</b>	2272	(a)
			2.18	III	20800	(92500)				2.64	III	21200	(94400)	03	<b>4D16DA</b>	2272	(a)
			2.66	III	20800	(92500)				3.22	III	21200	(94400)	03	<b>4D17DA</b>	2272	(a)
			1.26	I	12700	(56700)				1.53	II	13900	(61800)	03	<b>4C14DA</b>	2559	(a)
0.493	37500	(4240)	1.39	I	12700	(56700)	0.595	31100	(3510)	1.68	II	13900	(61800)	03	<b>4C16DA</b>	2559	(a)
			1.94	II	20400	(90900)				2.34	III	21000	(93300)	03	<b>4D16DA</b>	2559	(a)
			2.37	III	20400	(90900)				2.86	III	21000	(93300)	03	<b>4D17DA</b>	2559	(a)
			2.91	III	22200	(98500)				3.51	III	22400	(99800)	03	<b>4E17DA</b>	2559	(a)
			1.10	I	11400	(50900)				1.33	I	13100	(58200)	03	<b>4C14DB</b>	2944	(a)
0.413	44800	(5060)	1.69	II	19900	(88400)	0.499	37100	(4190)	2.03	III	20600	(91600)	03	<b>4D16DA</b>	2944	(a)
			2.06	III	19900	(88400)				2.48	III	20600	(91600)	03	<b>4D17DA</b>	2944	(a)
			2.53	III	21900	(97400)				3.05	III	22200	(98900)	03	<b>4E17DA</b>	2944	(a)
			2.74	III	21900	(97400)				3.30	III	22200	(98900)	03	<b>4E18DA</b>	2944	(a)
0.332	55700	(6290)	0.92	-	8720	(38800)	0.401	46100	(5210)	1.11	I	11600	(51500)	03	<b>4C14DA</b>	3511	(a)
			1.41	II	18800	(83800)				1.71	II	19900	(88600)	03	<b>4D16DA</b>	3511	(a)
			1.72	II	18800	(83800)				2.08	III	19900	(88600)	03	<b>4D17DA</b>	3511	(a)
			2.12	III	21500	(95800)				2.56	III	21900	(97500)	03	<b>4E17DA</b>	3511	(a)
			1.39	I	16800	(74600)				1.67	II	18600	(82800)	03	<b>4D17DA</b>	4365	(a)
0.280	66000	(7460)	1.70	II	21000	(93300)	0.338	54700	(6180)	2.06	III	21500	(95500)	03	<b>4E17DA</b>	4365	(a)
			2.71	III	29800	(132000)				3.27							

# Standard Mounting Selection Tables

**1/2 HP  
(0.4 kW)**

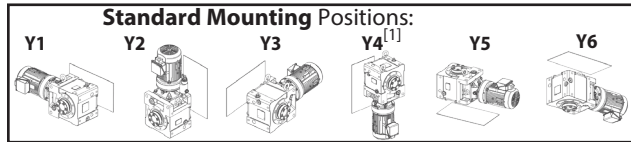

Dimension Pages:  
Single Reduction 2.132-2.143  
Single Reduction, Y2 2.144  
Double Reduction 2.146-2.161  
Double Reduction, Y2 2.162

Frequency	50 Hz	60 Hz
Input Speed	1450 RPM	1750 RPM
Number of Poles	4	

50Hz					60 Hz					Selection							
Output Speed (RPM)	Output Torque		Service Factor		Solid Shaft Overhung Load		Output Speed (RPM)	Output Torque		Service Factor		Solid Shaft Overhung Load		Base			VFD <sup>[2]</sup>
	in-lbs	(N·m)	SF	AGMA Class	lbs	(N)		in-lbs	(N·m)	SF	AGMA Class	lbs	(N)	Motor Power Code	Frame Size	Ratio	
12.9	2410 (272)		2.44	III	6050 (26900)		15.6	2000 (225)		2.44	III	6080 (27100)	05	4A100	112	(a)	
			3.00	III	6050 (26900)	6080 (27100)											
11.8	2630 (298)		2.44	III	6030 (26800)		14.3	2180 (247)		2.44	III	6070 (27000)	05	4A100	123	(a)	
			3.00	III	6030 (26800)	6070 (27000)											
9.63	3240 (366)		1.95	II	5970 (26500)		11.6	2680 (303)		1.95	II	6020 (26800)	05	4A100	151	(a)	
			2.70	III	5970 (26500)	6020 (26800)											
8.12	3840 (434)		1.40	II	5890 (26200)		9.80	3180 (359)		1.40	II	5970 (26600)	05	4A100	179	(a)	
			1.94	II	5890 (26200)	5970 (26600)											
			2.36	III	5890 (26200)	5970 (26600)											
			2.78	III	5890 (26200)	5970 (26600)											
			2.98	III	5890 (26200)	5970 (26600)											
7.02	4440 (502)		1.29	I	5800 (25800)		8.47	3680 (416)		1.29	I	5910 (26300)	05	4A100	207	(a)	
			1.70	II	5800 (25800)	5910 (26300)											
			2.15	III	5800 (25800)	5910 (26300)											
			2.53	III	5800 (25800)	5910 (26300)											
			2.57	III	5800 (25800)	5910 (26300)											
5.84	5340 (604)		1.09	I	5630 (25000)		7.04	4430 (500)		1.09	I	5800 (25800)	05	4A100	249	(a)	
			1.26	I	5630 (25000)	5800 (25800)											
			1.67	II	5630 (25000)	5800 (25800)											
			1.90	II	5630 (25000)	5800 (25800)											
			2.14	III	5630 (25000)	5800 (25800)											
			2.39	III	9860 (43900)	9920 (44100)											
			2.84	III	9860 (43900)	9920 (44100)											
4.76	6550 (740)		1.08	I	5350 (23800)		5.75	5420 (613)		1.08	I	5610 (25000)	05	4A100	305	(a)	
			1.26	I	5350 (23800)	5610 (25000)											
			1.65	II	5350 (23800)	5610 (25000)											
			1.74	II	5350 (23800)	5610 (25000)											
			2.36	III	9760 (43400)	9850 (43800)											
			2.57	III	9760 (43400)	9850 (43800)											
3.98	7430 (839)		1.02	I	4970 (22100)		4.81	6150 (695)		1.02	I	5370 (23900)	05	4A10DA	364	C.F.	
			1.54	II	4970 (22100)	5370 (23900)											
			2.55	III	9640 (42900)	9770 (43500)											
3.42	8640 (976)		1.02	I	4470 (19900)		4.13	7160 (809)		1.02	I	5060 (22500)	05	4A10DA	424	C.F.	
			1.32	I	4470 (19900)	5060 (22500)											
			2.17	III	9490 (42200)	9670 (43000)											
			2.63	III	9490 (42200)	9670 (43000)											
			3.18	III	9670 (43000)	9670 (43000)											

Notes: [1] For Y4 Double Reductions (4XXXDX) refer to the above table; for Y4 single reduction refer to tables on pages 2.91-2.130.  
[2] Variable Frequency Drive (VFD) notes (see page 2.8 for Constant Torque Speed Ranges):  
C.F. = Consult Factory with ambient temperature data for VFD operation.  
(a) = Both AV and non-AV motors can be used for selection.

# Standard Mounting Selection Tables

**1/2 HP  
(0.4 kW)**

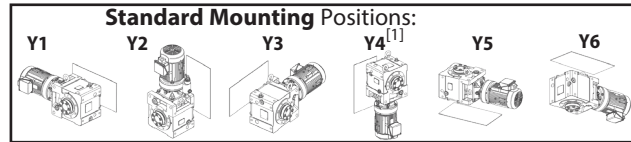

Dimension Pages:  
Single Reduction 2.132-2.143  
Single Reduction, Y2 2.144  
Double Reduction 2.146-2.161  
Double Reduction, Y2 2.162

Frequency	50 Hz	60 Hz
Input Speed	1450 RPM	1750 RPM
Number of Poles	4	

50Hz					60 Hz					Selection							
Output Speed (RPM)	Output Torque		Service Factor		Solid Shaft Overhung Load		Output Speed (RPM)	Output Torque		Service Factor		Solid Shaft Overhung Load		Base			VFD <sup>[2]</sup>
	in-lbs	(N·m)	SF	AGMA Class	lbs	(N)		in-lbs	(N·m)	SF	AGMA Class	lbs	(N)	Motor Power Code	Frame Size	Ratio	
2.90	10200 (1150)		0.88	-	3590 (16000)		3.50	8460 (956)		1.02	I	4550 (20300)	05	4A10DA	501	C.F.	
			1.12	I	3590 (16000)	4550 (20300)											
			1.86	II	9260 (41200)	9510 (42300)											
			2.23	III	9260 (41200)	9510 (42300)											
2.51	11800 (1330)		0.97	-	2160 (9600)		3.03	9760 (1100)		1.17	I	3880 (17300)	05	4A12DB	578	(a)	
			1.61	II	8980 (39900)	9330 (41500)											
			1.93	II	8980 (39900)	9330 (41500)											
2.12	13900 (1570)		1.02	I	8520 (37900)		2.56	11500 (1300)		1.02	I	9030 (40100)	05	4B12DA	683	C.F.	
			1.36	I	8520 (37900)	9030 (40100)											
			1.63	II	8520 (37900)	9030 (40100)											
			2.94	III	15600 (69300)	15800 (70100)											
1.79	16500 (1860)		1.02	I	7820 (34800)		2.16	13700 (1540)		1.02	I	8580 (38200)	05	4B12DA	809	C.F.	
			1.15	I	7820 (34800)	8580 (38200)											
			1.38	I	7820 (34800)	8580 (38200)											
			2.44	III	15300 (68300)	15600 (69400)											
			2.76	III	15300 (68300)	15600 (69400)											
			3.33	III	15600 (69400)	15600 (69400)											
1.52	19500 (2200)		0.97	-	6730 (29900)		1.83	16200 (1830)		1.17	I	7920 (35200)	05	4B12DB	956	(a)	
			1.17	I	6730 (29900)	7920 (35200)											
			2.07	III	15000 (66800)	15400 (68400)											
			2.33	III	15000 (66800)	15400 (68400)											
			2.82	III	15400 (68400)	15400 (68400)											
1.30	22800 (2570)		0.83	-	5000 (22200)		1.57	18900 (2130)		1.01	I	6990 (31100)	05	4B12DB	1117	(a)	
			1.00	I	5000 (22200)	6990 (31100)											
			1.81	II	14600 (64900)	15100 (67100)											
			2.00	III	14600 (64900)	15100 (67100)											
			2.78	III	21300 (94800)	21600 (95900)											
			3.35	III	21600 (95900)	21600 (95900)											
1.10	26900 (3040)		1.02	I	13900 (61900)		1.33	22300 (2520)		1.02	I	14700 (65200)	05	4C14DA	1320	C.F.	
			1.53	II	13900 (61900)	14700 (65200)											
			1.69	II	13900 (61900)	14700 (65200)											
			2.35	III	21000 (93400)	21300 (95000)											
			2.87	III	21000 (93400)	21300 (95000)											
			3.46	III	21300 (95000)	21300 (95000)											
0.876	33800 (3820)		1.02	I	12500 (55500)		1.06	28000 (3160)		1.02	I	13700 (61100)	05	4C14DA	1656	C.F.	
			1.22	I	12500 (55500)	13700 (61100)											
			1.35	I	12500 (55500)	13700 (61100)											
			1.87	II	20300 (90400)	20900 (92900)											
			2.28	III	20300 (90400)	20900 (92900)											
			2.81	III	22100 (98300)	22400 (99600)											
			3.39	III	22400 (99600)	22400 (99600)											
			3.46	III	21300 (95000)	21300 (95000)											
			3.46	III	21300 (95000)	21300 (95000)											

Notes: [1] For Y4 Double Reductions (4XXXDX) refer to the above table; for Y4 single reduction refer to tables on pages 2.91-2.130.  
[2] Variable Frequency Drive (VFD) notes (see page 2.8 for Constant Torque Speed Ranges):  
C.F. = Consult Factory with ambient temperature data for VFD operation.  
(a) = Both AV and non-AV motors can be used for selection.



# Standard Mounting Selection Tables

**1/2 HP**  
(0.4 kW)

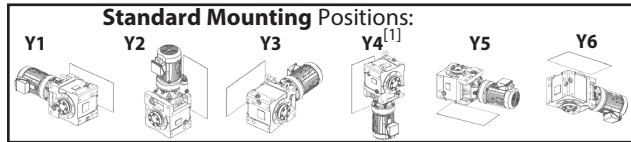

Dimension Pages:  
Single Reduction 2.132-2.143  
Single Reduction, Y2 2.144  
Double Reduction 2.146-2.161  
Double Reduction, Y2 2.162

Frequency	50 Hz	60 Hz
Input Speed	1450 RPM	1750 RPM
Number of Poles	4	

50Hz				60 Hz				Selection							
Output Speed (RPM)	Output Torque		Service Factor	Solid Shaft Overhung Load		Output Speed (RPM)	Output Torque		Service Factor	Solid Shaft Overhung Load		Base			VFD <sup>[2]</sup>
	in-lbs	(N·m)		lbs	(N)		in-lbs	(N·m)		lbs	(N)	Motor Power Code	Frame Size	Ratio	
0.741	39900 (4510)		1.03	I	10700 (47500)	0.894	33100 (3740)	1.25	I	12600 (56200)	05	4C14DB	1957	(a)	
			1.14	I	10700 (47500)			1.38	I	12600 (56200)	05	4C16DA	1957	(a)	
			1.58	II	19600 (87000)			1.91	II	20400 (90700)	05	4D16DA	1957	(a)	
			1.93	II	19600 (87000)			2.33	III	20400 (90700)	05	4D17DA	1957	(a)	
			2.38	III	21800 (96900)			2.87	III	22100 (98400)	05	4E17DA	1957	(a)	
			2.57	III	21800 (96900)			3.10	III	22100 (98400)	05	4E18DA	1957	(-)	
0.638	46300 (5240)		0.89	-	7920 (35200)	0.770	38400 (4340)	1.07	I	11200 (49700)	05	4C14DB	2272	(a)	
			0.98	-	7920 (35200)			1.18	I	11200 (49700)	05	4C16DA	2272	(a)	
			1.36	I	18600 (82600)			1.65	II	19800 (87900)	05	4D16DA	2272	(a)	
			1.67	II	18600 (82600)			2.01	III	19800 (87900)	05	4D17DA	2272	(a)	
			2.05	III	21500 (95400)			2.47	III	21900 (97200)	05	4E17DA	2272	(a)	
			2.22	III	21500 (95400)			2.67	III	21900 (97200)	05	4E18DA	2272	(-)	
0.567	52200 (5900)		0.87	-	3100 (13800)	0.684	43300 (4890)	1.05	I	9390 (41800)	05	4C16DA	2559	(a)	
			1.21	I	17500 (77900)			1.46	II	19100 (84800)	05	4D16DA	2559	(a)	
			1.48	II	17500 (77900)			1.78	II	19100 (84800)	05	4D17DA	2559	(a)	
			1.82	II	21200 (94100)			2.19	III	21600 (96100)	05	4E17DA	2559	(a)	
			1.97	II	21200 (94100)			2.37	III	21600 (96100)	05	4E18DA	2559	(a)	
			2.88	III	29900 (133000)			3.48	III	30300 (135000)	05	4F18DA	2559	(a)	
0.493	60100 (6790)		1.05	I	15700 (70000)	0.595	49800 (5620)	1.27	I	18000 (80000)	05	4D16DA	2944	(a)	
			1.29	I	15700 (70000)			1.55	II	18000 (80000)	05	4D17DA	2944	(a)	
			1.58	II	20800 (92400)			1.91	II	21300 (94700)	05	4E17DA	2944	(a)	
			1.71	II	20800 (92400)			2.06	III	21300 (94700)	05	4E18DA	2944	(a)	
			2.56	III	29600 (132000)			3.09	III	30000 (134000)	05	4F19DA	2944	(-)	
			0.413	71600 (8090)				0.88	-	12100 (53600)	0.499	59300 (6710)	1.07	I	15900 (70800)
1.08	I	12100 (53600)				1.30	I	15900 (70800)	05	4D17DA			3511	(a)	
1.32	I	20200 (89700)				1.60	II	20800 (92500)	05	4E17DA			3511	(a)	
2.10	III	29100 (129000)				2.54	III	29600 (132000)	05	4F18DA			3511	(a)	
2.15	III	29100 (129000)				2.60	III	29600 (132000)	05	4F19DA			3511	(a)	
0.332	89000 (10100)					1.07	I	19300 (85800)	0.401	73800 (8340)			1.29	I	20100 (89300)
			1.69	II	28300 (126000)	2.04	III	29000 (129000)			05	4F18DA	4365	(a)	
			1.73	II	28300 (126000)	2.09	III	29000 (129000)			05	4F19DA	4365	(-)	
0.280	106000 (11900)	0.90	-	16100 (71600)	0.338	87500 (9890)	1.08	I	19400 (86200)	05	4E17DA	5177	(a)		

Notes: [1] For Y4 Double Reductions (4XXXDX) refer to the above table; for Y4 single reduction refer to tables on pages 2.91-2.130.  
[2] Variable Frequency Drive (VFD) notes (see page 2.8 for Constant Torque Speed Ranges):  
(-) = For Inverter Operation, starting condition may require ambient temperature of 5° C or higher.  
(a) = Both AV and non-AV motors can be used for selection.

# Standard Mounting Selection Tables

**3/4 HP**  
(0.55 kW)

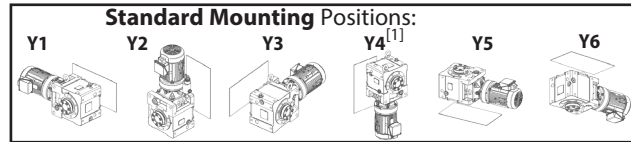

Dimension Pages:  
Single Reduction 2.132-2.143  
Single Reduction, Y2 2.144  
Double Reduction 2.146-2.161  
Double Reduction, Y2 2.162

Frequency	50 Hz	60 Hz
Input Speed	1450 RPM	1750 RPM
Number of Poles	4	

50Hz				60 Hz				Selection							
Output Speed (RPM)	Output Torque		Service Factor	Solid Shaft Overhung Load		Output Speed (RPM)	Output Torque		Service Factor	Solid Shaft Overhung Load		Base			VFD <sup>[2]</sup>
	in-lbs	(N·m)		lbs	(N)		in-lbs	(N·m)		lbs	(N)	Motor Power Code	Frame Size	Ratio	
18.1	2360 (267)		2.31	III	6050 (26900)	21.9	1960 (221)	2.31	III	6080 (27100)	08	4A100	80	(a)	
16.6	2590 (292)		2.31	III	6030 (26800)	20.0	2140 (242)	2.31	III	6070 (27000)	08	4A100	88	(a)	
14.3	3000 (339)		2.20	III	5990 (26700)	17.2	2490 (281)	2.20	III	6040 (26900)	08	4A100	102	(a)	
			2.89	III	5990 (26700)			2.89	III	6040 (26900)	08	4A105	102	(a)	
12.9	3310 (374)		1.77	II	5960 (26500)	15.6	2740 (310)	1.77	II	6020 (26800)	08	4A100	112	(a)	
			2.18	III	5960 (26500)			2.18	III	6020 (26800)	08	4A105	112	(a)	
			2.73	III	5960 (26500)			2.73	III	6020 (26800)	08	4A110	112	(a)	
11.8	3620 (409)		1.77	II	5920 (26300)	14.3	3000 (339)	1.77	II	5990 (26700)	08	4A100	123	(a)	
			2.18	III	5920 (26300)			2.18	III	5990 (26700)	08	4A105	123	(a)	
			2.73	III	5920 (26300)			2.73	III	5990 (26700)	08	4A110	123	(a)	
9.63	4450 (503)		1.42	II	5800 (25800)	11.6	3690 (416)	1.42	II	5910 (26300)	08	4A100	151	(a)	
			1.96	II	5800 (25800)			1.96	II	5910 (26300)	08	4A105	151	(a)	
			2.36	III	5800 (25800)			2.36	III	5910 (26300)	08	4A110	151	(a)	
8.12	5280 (596)		1.02	I	5640 (25100)	9.80	4370 (494)	1.02	I	5810 (25800)	08	4A100	179	(a)	
			1.41	II	5640 (25100)			1.41	II	5810 (25800)	08	4A105	179	(a)	
			1.72	II	5640 (25100)			1.72	II	5810 (25800)	08	4A110	179	(a)	
7.02	6100 (690)		2.02	III	5640 (25100)	8.47	5060 (571)	2.02	III	5810 (25800)	08	4A115	179	(a)	
			2.16	III	5640 (25100)			2.16	III	5810 (25800)	08	4A120	179	(a)	
			2.96	III	9860 (43900)			3.13	III	9920 (44100)	08	4B120	179	(a)	
			1.24	I	5460 (24300)			1.29	I	5690 (25300)	08	4A105	207	(a)	
5.84	7350 (830)		1.56	II	5460 (24300)	7.04	6090 (688)	1.56	II	5690 (25300)	08	4A110	207	(a)	
			1.84	II	5460 (24300)			1.84	II	5690 (25300)	08	4A115	207	(a)	
			1.87	II	5460 (24300)			1.87	II	5690 (25300)	08	4A120	207	(a)	
			2.36	III	9800 (43600)			2.36	III	9880 (43900)	08	4B120	207	(a)	
			2.95	III	9800 (43600)			2.95	III	9880 (43900)	08	4B125	207	(a)	
4.76	9000 (1020)		0.92	-	5120 (22800)	5.75	7460 (843)	1.02	I	5470 (24300)	08	4A105	249	(a)	
			1.22	I	5120 (22800)			1.22	I	5470 (24300)	08	4A110	249	(a)	
			1.38	I	5120 (22800)			1.38	I	5470 (24300)	08	4A115	249	(a)	
			1.55	II	5120 (22800)			1.55	II	5470 (24300)	08	4A120	249	(a)	
			1.74	II	9690 (43100)			1.74	II	9800 (43600)	08	4B120	249	(a)	
			2.07	III	9690 (43100)			2.18	III	9800 (43600)	08	4B125	249	(a)	
1.20	4520 (20100)		1.20	I	4520 (20100)	5.75	7460 (843)	1.03	I	5090 (22600)	08	4A105	305	(a)	
			1.27	I	4520 (20100)			1.20	I	5090 (22600)	08	4A110	305	(a)	
			1.72	II	9500 (42300)			1.27	I	5090 (22600)	08	4A115	305	(a)	
			1.87	II	9500 (42300)			1.72	II	9680 (43000)	08	4B120	305	(a)	
			2.53	III	9500 (42300)			2.05	III	9680 (43000)	08	4B125	305	(a)	
2.53	III	9500 (42300)	2.53	III	9680 (43000)	08	4B140	305	(a)						

Notes: [1] For Y4 Double Reductions (4XXXDX) refer to the above table; for Y4 single reduction refer to tables on pages 2.91-2.130.  
[2] Variable Frequency Drive (VFD) notes (see page 2.8 for Constant Torque Speed Ranges):  
(a) = Both AV and non-AV motors can be used for selection.



# Standard Mounting Selection Tables

**3/4 HP**  
(0.55 kW)

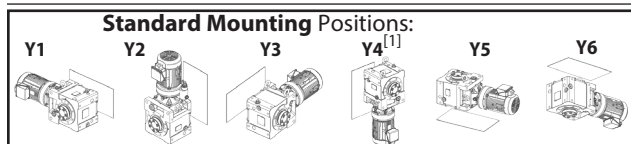

Dimension Pages:  
Single Reduction, Y2 2.132-2.143  
Single Reduction, Y2 2.144  
Double Reduction 2.146-2.161  
Double Reduction, Y2 2.162

Frequency	50 Hz	60 Hz
Input Speed	1450 RPM	1750 RPM
Number of Poles	4	

50Hz					60 Hz					Selection							
Output Speed (RPM)	Output Torque		Service Factor		Solid Shaft Overhung Load		Output Speed (RPM)	Output Torque		Service Factor		Solid Shaft Overhung Load		Base			VFD <sup>[2]</sup>
	in-lbs	(N·m)	SF	AGMA Class	lbs	(N)		in-lbs	(N·m)	SF	AGMA Class	lbs	(N)	Motor Power Code	Frame Size	Ratio	
3.98	10200 (1150)		1.12	I	3590 (16000)	4.81	8460 (956)		1.35	I	4550 (20300)	08	4A12DB	364	(a)		
			1.86	II	9260 (41200)				2.24	III	9510 (42300)					4B12DB	
			2.23	III	9260 (41200)				2.69	III	9510 (42300)					4B14DB	
			2.75	III	15800 (70500)				2.75	III	15900 (70900)					4C14DB	
3.42	11900 (1340)		0.96	-	2030 (9010)	4.13	9840 (1110)		1.16	I	3830 (17000)	08	4A12DB	424	(a)		
			1.58	II	8960 (39900)				1.90	II	9310 (41400)					4B12DB	
			1.91	II	8960 (39900)				2.31	III	9310 (41400)					4B14DB	
			2.75	III	15700 (70000)				2.75	III	15900 (70600)					4C14DB	
2.90	14000 (1590)		1.35	I	8490 (37800)	3.50	11600 (1310)		1.63	II	9010 (40100)	08	4B12DB	501	(a)		
			1.62	II	8490 (37800)				1.96	II	9010 (40100)					4B14DB	
			2.75	III	15600 (69300)				2.75	III	15800 (70100)					4C14DB	
			2.94	III	15600 (69300)				3.55	III	15800 (70100)					4C14DC	
2.51	16200 (1830)		1.17	I	7910 (35200)	3.03	13400 (1520)		1.41	II	8640 (38400)	08	4B12DB	578	(a)		
			1.40	II	7910 (35200)				1.69	II	8640 (38400)					4B14DB	
			2.52	III	15400 (68400)				2.75	III	15600 (69500)					4C14DB	
			2.81	III	15400 (68400)				3.39	III	15600 (69500)					4C16DC	
2.12	19100 (2160)		0.99	-	6880 (30600)	2.56	15900 (1790)		1.20	I	8010 (35600)	08	4B12DB	683	(a)		
			1.19	I	6880 (30600)				1.43	II	8010 (35600)					4B14DB	
			2.14	III	15100 (67000)				2.58	III	15400 (68500)					4C14DB	
			2.38	III	15100 (67000)				2.75	III	15400 (68500)					4C16DA	
1.79	22700 (2560)		0.84	-	5060 (22500)	2.16	18800 (2120)		1.01	I	7020 (31200)	08	4B12DB	809	(a)		
			1.00	I	5060 (22500)				1.21	I	7020 (31200)					4B14DB	
			1.78	II	14600 (64900)				2.14	III	15100 (67200)					4C14DB	
			2.01	III	14600 (64900)				2.42	III	15100 (67200)					4C16DA	
1.52	26800 (3030)		1.50	II	13900 (62000)	1.83	22200 (2510)		1.81	II	14700 (65200)	08	4C14DB	956	(a)		
			1.70	II	13900 (62000)				2.05	III	14700 (65200)					4C16DA	
			2.36	III	21000 (93400)				2.75	III	21400 (95000)					4D16DA	
			2.88	III	21000 (93400)				3.47	III	21400 (95000)					4D17DC	
1.30	31300 (3540)		1.32	I	13000 (58000)	1.57	26000 (2930)		1.59	II	14100 (62700)	08	4C14DB	1117	(a)		
			1.45	II	13000 (58000)				1.75	II	14100 (62700)					4C16DA	
			2.02	III	20600 (91500)				2.44	III	21100 (93700)					4D16DA	
			2.46	III	20600 (91500)				2.75	III	21100 (93700)					4D17DA	

Notes: [1] For Y4 Double Reductions (4XXXDX) refer to the above table; for Y4 single reduction refer to tables on pages 2.91-2.130.

[2] Variable Frequency Drive (VFD) notes (see page 2.8 for Constant Torque Speed Ranges):

(a) = Both AV and non-AV motors can be used for selection.

# Standard Mounting Selection Tables

**3/4 HP**  
(0.55 kW)

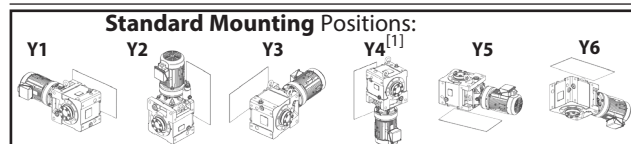

Dimension Pages:  
Single Reduction 2.132-2.143  
Single Reduction, Y2 2.144  
Double Reduction 2.146-2.161  
Double Reduction, Y2 2.162

Frequency	50 Hz	60 Hz
Input Speed	1450 RPM	1750 RPM
Number of Poles	4	

50Hz					60 Hz					Selection							
Output Speed (RPM)	Output Torque		Service Factor		Solid Shaft Overhung Load		Output Speed (RPM)	Output Torque		Service Factor		Solid Shaft Overhung Load		Base			VFD <sup>[2]</sup>
	in-lbs	(N·m)	SF	AGMA Class	lbs	(N)		in-lbs	(N·m)	SF	AGMA Class	lbs	(N)	Motor Power Code	Frame Size	Ratio	
1.10	37000 (4180)		1.11	I	11600 (51600)	1.33	30700 (3470)		1.35	I	13200 (58700)	08	4C14DB	1320	(a)		
			1.23	I	11600 (51600)				1.48	II	13200 (58700)					4C16DA	
			1.71	II	19900 (88700)				2.06	III	20600 (91800)					4D16DA	
			2.08	III	19900 (88700)				2.52	III	20600 (91800)					4D17DA	
			2.56	III	21900 (97500)				2.75	III	22300 (99000)					4E17DA	
0.876	46400 (5250)		0.89	-	7870 (35000)	1.06	38500 (4350)		1.07	I	11100 (49600)	08	4C14DB	1656	(a)		
			0.98	-	7870 (35000)				1.18	I	11100 (49600)					4C16DA	
			1.36	I	18600 (82600)				1.64	II	19700 (87800)					4D16DA	
			1.66	II	18600 (82600)				2.01	III	19700 (87800)					4D17DA	
			2.04	III	21500 (95400)				2.47	III	21900 (97200)					4E17DA	
0.741	54900 (6200)		1.15	I	16900 (75400)	0.894	45500 (5140)		1.39	I	18700 (83300)	08	4D16DA	1957	(a)		
			1.41	II	16900 (75400)				1.70	II	18700 (83300)					4D17DA	
			1.73	II	21000 (93500)				2.09	III	21500 (95600)					4E17DA	
			1.87	II	21000 (93500)				2.26	III	21500 (95600)					4E18DA	
			2.74	III	29800 (133000)				3.31	III	30200 (134000)					4F18DA	
0.638	63700 (7200)		0.99	-	14700 (65500)	0.770	52800 (5970)		1.20	I	17400 (77300)	08	4D16DA	2272	(a)		
			1.21	I	14700 (65500)				1.46	II	17400 (77300)					4D17DA	
			1.49	II	20600 (91500)				1.80	II	21100 (94000)					4E17DA	
			1.61	II	20600 (91500)				1.94	II	21100 (94000)					4E18DA	
			2.36	III	29400 (131000)				2.85	III	29900 (133000)					4F18DA	
0.567	71800 (8110)		0.88	-	12000 (53300)	0.684	59500 (6720)		1.06	I	15900 (70600)	08	4D16DA	2559	(a)		
			1.08	I	12000 (53300)				1.30	I	15900 (70600)					4D17DA	
			1.32	I	20200 (89700)				1.60	II	20800 (92500)					4E17DA	
			1.43	II	20200 (89700)				1.73	II	20800 (92500)					4E18DA	
			2.10	III	29100 (129000)				2.53	III	29600 (132000)					4F18DA	
0.493	82600 (9330)		0.93	-	5670 (25200)	0.595	68400 (7730)		1.13	I	13200 (58900)	08	4D17DA	2944	(a)		
			1.15	I	19600 (87300)				1.39	I	20300 (90500)					4E17DA	
			1.24	I	19600 (87300)				1.50	II	20300 (90500)					4E18DA	
			1.82	II	28600 (127000)				2.20	III	29200 (130000)					4F18DA	
			1.87	II	28600 (127000)				2.25	III	29200 (130000)					4F19DA	
0.413	98500 (11100)		0.96	-	18200 (80800)	0.499	81600 (9220)		1.16	I	19700 (87500)	08	4E17DA	3511	(a)		
			1.53	II	27900 (124000)				1.85	II	28600 (127000)					4F18DA	
			1.56	II	27900 (124000)				1.89	II	28600 (127000)					4F19DA	

Notes: [1] For Y4 Double Reductions (4XXXDX) refer to the above table; for Y4 single reduction refer to tables on pages 2.91-2.130.

[2] Variable Frequency Drive (VFD) notes (see page 2.8 for Constant Torque Speed Ranges):

(a) = Both AV and non-AV motors can be used for selection.

# Standard Mounting Selection Tables

**3/4 HP**  
(0.55 kW)

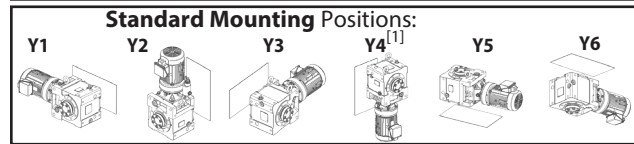

Dimension Pages:  
Single Reduction 2.132-2.143  
Single Reduction, Y2 2.144  
Double Reduction 2.146-2.161  
Double Reduction, Y2 2.162

Frequency	50 Hz	60 Hz
Input Speed	1450 RPM	1750 RPM
Number of Poles	4	

50Hz				60 Hz				Selection							
Output Speed (RPM)	Output Torque		Service Factor		Solid Shaft Overhung Load		Output Speed (RPM)	Output Torque		Service Factor		Base			
	in-lbs	(N·m)	SF	AGMA Class	lbs	(N)		in-lbs	(N·m)	SF	AGMA Class	lbs	(N)	Motor Power Code	Frame Size
0.332	122000 (13800)		1.23	I	26900 (120000)	0.401	101000 (11500)	1.48	II	27800 (124000)	08	<b>4F18DA</b>	4365	(a)	
			1.26	I	26900 (120000)	1.52	II	27800 (124000)	08	<b>4F19DA</b>	4365	(a)			

# Standard Mounting Selection Tables

**1 HP**  
(0.75 kW)

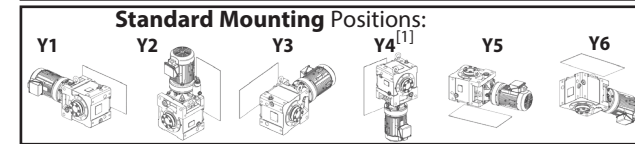

Dimension Pages:  
Single Reduction 2.132-2.143  
Single Reduction, Y2 2.144  
Double Reduction 2.146-2.161  
Double Reduction, Y2 2.162

Frequency	50 Hz	60 Hz
Input Speed	1450 RPM	1750 RPM
Number of Poles	4	

50Hz				60 Hz				Selection							
Output Speed (RPM)	Output Torque		Service Factor		Solid Shaft Overhung Load		Output Speed (RPM)	Output Torque		Service Factor		Base			
	in-lbs	(N·m)	SF	AGMA Class	lbs	(N)		in-lbs	(N·m)	SF	AGMA Class	lbs	(N)	Motor Power Code	Frame Size
24.4	2400 (271)		2.65	III	6050 (26900)	29.4	1990 (225)	2.65	III	6080 (27100)	1	<b>4A100</b>	60		
21.6	2710 (306)		2.54	III	6020 (26800)	26.0	2240 (254)	2.57	III	6060 (27000)	1	<b>4A100</b>	67		
19.7	2960 (335)		2.54	III	6000 (26700)	23.8	2450 (277)	2.57	III	6050 (26900)	1	<b>4A100</b>	74		
18.1	3220 (364)		1.69	II	5970 (26500)	21.9	2670 (302)	1.69	II	6030 (26800)	1	<b>4A100</b>	80		
			2.23	III	5970 (26500)			2.23	III	6030 (26800)	1	<b>4A105</b>	80		
			2.55	III	5970 (26500)			2.55	III	6030 (26800)	1	<b>4A110</b>	80		
			2.96	III	5970 (26500)			2.96	III	6030 (26800)	1	<b>4A115</b>	80		
16.6	3530 (399)		1.69	II	5930 (26400)	20.0	2920 (330)	1.69	II	6000 (26700)	1	<b>4A100</b>	88		
			2.23	III	5930 (26400)			2.23	III	6000 (26700)	1	<b>4A105</b>	88		
			2.55	III	5930 (26400)			2.55	III	6000 (26700)	1	<b>4A110</b>	88		
			2.96	III	5930 (26400)			2.96	III	6000 (26700)	1	<b>4A115</b>	88		
14.3	4090 (462)		1.61	II	5850 (26000)	17.2	3390 (383)	1.61	II	5950 (26500)	1	<b>4A100</b>	102		
			2.12	III	5850 (26000)			2.12	III	5950 (26500)	1	<b>4A105</b>	102		
			2.53	III	5850 (26000)			2.53	III	5950 (26500)	1	<b>4A110</b>	102		
			2.79	III	5850 (26000)			2.79	III	5950 (26500)	1	<b>4A115</b>	102		
12.9	4510 (510)		1.30	I	5780 (25700)	15.6	3740 (423)	1.30	I	5900 (26300)	1	<b>4A100</b>	112		
			1.60	II	5780 (25700)			1.60	II	5900 (26300)	1	<b>4A105</b>	112		
			2.00	III	5780 (25700)			2.00	III	5900 (26300)	1	<b>4A110</b>	112		
			2.41	III	5780 (25700)			2.41	III	5900 (26300)	1	<b>4A115</b>	112		
11.8	4940 (558)		1.30	I	5710 (25400)	14.3	4090 (462)	1.30	I	5850 (26000)	1	<b>4A100</b>	123		
			1.60	II	5710 (25400)			1.60	II	5850 (26000)	1	<b>4A105</b>	123		
			2.00	III	5710 (25400)			2.00	III	5850 (26000)	1	<b>4A110</b>	123		
			2.31	III	5710 (25400)			2.31	III	5850 (26000)	1	<b>4A115</b>	123		
9.63	6070 (685)		1.04	I	5470 (24300)	11.6	5030 (568)	1.04	I	5690 (25300)	1	<b>4A100</b>	151		
			1.44	II	5470 (24300)			1.44	II	5690 (25300)	1	<b>4A105</b>	151		
			1.88	II	5470 (24300)			1.88	II	5690 (25300)	1	<b>4A115</b>	151		
			2.55	III	9800 (43600)			2.55	III	9880 (44000)	1	<b>4B120</b>	151		
8.12	7200 (813)		1.03	I	5170 (23000)	9.80	5960 (674)	1.03	I	5490 (24400)	1	<b>4A105</b>	179		
			1.26	I	5170 (23000)			1.26	I	5490 (24400)	1	<b>4A110</b>	179		
			1.48	II	5170 (23000)			1.48	II	5490 (24400)	1	<b>4A115</b>	179		
			1.59	II	5170 (23000)			1.59	II	5490 (24400)	1	<b>4A120</b>	179		
			2.17	III	9700 (43200)			2.29	III	9810 (43600)	1	<b>4B120</b>	179		
			2.63	III	9700 (43200)			3.04	III	9810 (43600)	1	<b>4B125</b>	179		

Notes: [1] For Y4 Double Reductions (4XXXDX) refer to the above table; for Y4 single reduction refer to tables on pages 2.91-2.130.

[2] Variable Frequency Drive (VFD) notes (see page 2.8 for Constant Torque Speed Ranges):

(a) = Both AV and non-AV motors can be used for selection.

Notes: [1] For Y4 Double Reductions (4XXXDX) refer to the above table; for Y4 single reduction refer to tables on pages 2.91-2.130..

[2] Variable Frequency Drive (VFD) notes (see page 2.8 for Constant Torque Speed Ranges):

All 1HP+ motors require EP suffix in model number and can be used with a VFD, unless noted.

# Standard Mounting Selection Tables

**1 HP**  
(0.75 kW)

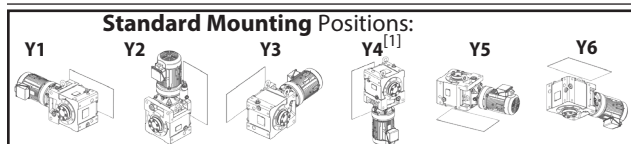

Dimension Pages:  
Single Reduction 2.132-2.143  
Single Reduction, Y2 2.144  
Double Reduction 2.146-2.161  
Double Reduction, Y2 2.162

Frequency	50 Hz	60 Hz
Input Speed	1450 RPM	1750 RPM
Number of Poles	4	

50Hz					60 Hz					Selection							
Output Speed (RPM)	Output Torque		Service Factor		Solid Shaft Overhung Load		Output Speed (RPM)	Output Torque		Service Factor		Solid Shaft Overhung Load		Base			VFD <sup>[2]</sup>
	in-lbs	(N·m)	SF	AGMA Class	lbs	(N)		in-lbs	(N·m)	SF	AGMA Class	lbs	(N)	Motor Power Code	Frame Size	Ratio	
7.02	8320 (940)		0.91	-	4790 (21300)	8.47	6900 (779)		0.94	-	5250 (23400)	1	4A105	207			
			1.15	I	4790 (21300)				1.15	I	5250 (23400)						4A110
			1.35	I	4790 (21300)				1.35	I	5250 (23400)						4A115
			1.73	II	9580 (42600)				1.73	II	9730 (43300)						4B120
			2.16	III	9580 (42600)				2.16	III	9730 (43300)						4B125
			2.73	III	9580 (42600)				2.73	III	9730 (43300)						4B140
5.84	10000 (1130)		1.01	I	4030 (17900)	7.04	8300 (938)		1.01	I	4800 (21300)	1	4A115	249			
			1.14	I	4030 (17900)				1.14	I	4800 (21300)						4A120
			1.28	I	9370 (41700)				1.28	I	9590 (42600)						4B120
			1.52	II	9370 (41700)				1.60	II	9590 (42600)						4B125
			2.27	III	9370 (41700)				2.27	III	9590 (42600)						4B145
4.76	12300 (1390)		0.93	-	2330 (10300)	5.75	10200 (1150)		0.93	-	3950 (17600)	1	4A115	305			
			1.26	I	9000 (40100)				1.26	I	9340 (41600)						4B120
			1.37	I	9000 (40100)				1.51	II	9340 (41600)						4B125
			1.85	II	9000 (40100)				1.85	II	9340 (41600)						4B145
			2.64	III	15700 (70100)				2.64	III	15900 (70600)						4C140
			3.98	III	15600 (69300)				3.98	III	15800 (70100)						4C14DC
3.42	16200 (1830)		1.16	I	7910 (35200)	4.13	13400 (1520)		1.40	II	8640 (38400)	1	4B12DB	424			
			1.40	II	7910 (35200)				1.69	II	8640 (38400)						4B14DB
			2.02	III	15400 (68400)				2.02	III	15600 (69500)						4C14DB
			2.40	III	15400 (68400)				2.90	III	15600 (69500)						4C14DC
			2.81	III	15400 (68400)				3.39	III	15600 (69500)						4C16DB
2.90	19100 (2160)		0.99	-	6880 (30600)	3.50	15900 (1790)		1.20	I	8010 (35600)	1	4B12DB	501			
			1.19	I	6880 (30600)				1.43	II	8010 (35600)						4B14DB
			2.02	III	15100 (67000)				2.02	III	15400 (68500)						4C14DB
			2.38	III	15100 (67000)				2.87	III	15400 (68500)						4C16DB
			2.51	III	15100 (67000)				2.51	III	15100 (67000)						4C16DB
2.51	22100 (2500)		0.86	-	5430 (24200)	3.03	18300 (2070)		1.04	I	7200 (32000)	1	4B12DB	578			
			1.03	I	5430 (24200)				1.24	I	7200 (32000)						4B14DB
			1.85	II	14700 (65300)				2.02	III	15200 (67400)						4C14DB
			2.06	III	14700 (65300)				2.49	III	15200 (67400)						4C16DB
			2.86	III	21400 (95000)				3.46	III	21600 (96100)						4D16DB
			0.876	I	14800 (66000)				1.22	I	14800 (66000)						4B14DB
			1.50	II	20600 (91600)				1.62	II	20600 (91600)						4C14DB
			2.38	III	29400 (131000)				2.43	III	29400 (131000)						4F19DA

Notes: [1] For Y4 Double Reductions (4XXXDX) refer to the above table; for Y4 single reduction refer to tables on pages 2.91-2.130.

[2] Variable Frequency Drive (VFD) notes (see page 2.8 for Constant Torque Speed Ranges):

All 1HP+ motors require EP suffix in model number and can be used with a VFD, unless noted.

# Standard Mounting Selection Tables

**1 HP**  
(0.75 kW)

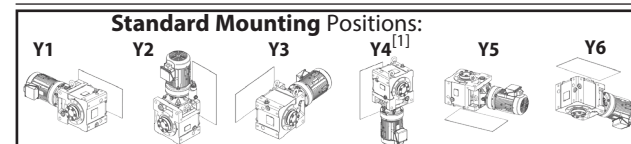

Dimension Pages:  
Single Reduction 2.132-2.143  
Single Reduction, Y2 2.144  
Double Reduction 2.146-2.161  
Double Reduction, Y2 2.162

Frequency	50 Hz	60 Hz
Input Speed	1450 RPM	1750 RPM
Number of Poles	4	

50Hz					60 Hz					Selection							
Output Speed (RPM)	Output Torque		Service Factor		Solid Shaft Overhung Load		Output Speed (RPM)	Output Torque		Service Factor		Solid Shaft Overhung Load		Base			VFD <sup>[2]</sup>
	in-lbs	(N·m)	SF	AGMA Class	lbs	(N)		in-lbs	(N·m)	SF	AGMA Class	lbs	(N)	Motor Power Code	Frame Size	Ratio	
2.12	26100 (2950)		0.87	-	1070 (4750)	2.56	21600 (2440)		1.05	I	5690 (25300)	1	4B14DB	683			
			1.57	II	14100 (62600)				1.89	II	14700 (65600)						4C14DB
			1.74	II	14100 (62600)				2.02	III	14700 (65600)						4C16DA
			2.02	III	21100 (93700)				2.02	III	21400 (95200)						4D16DA
			2.42	III	21100 (93700)				2.92	III	21400 (95200)						4D16DB
			2.96	III	21100 (93700)				3.57	III	21400 (95200)						4D17DB
1.79	30900 (3490)		1.30	I	13100 (58400)	2.16	25600 (2900)		1.57	II	14100 (62900)	1	4C14DB	809			
			2.02	III	20600 (91700)				2.02	III	21100 (93800)						4D16DA
			2.50	III	20600 (91700)				3.01	III	21100 (93800)						4D17DB
1.52	36600 (4130)		1.10	I	11700 (52200)	1.83	30300 (3420)		1.33	I	13300 (59000)	1	4C14DB	956			
			1.24	I	11700 (52200)				1.50	II	13300 (59000)						4C16DA
			1.73	II	20000 (88900)				2.02	III	20700 (92000)						4D16DA
			2.02	III	22000 (97700)				2.02	III	22300 (99100)						4E17DA
			2.60	III	22000 (97700)				3.13	III	22300 (99100)						4E17DB
			2.81	III	22000 (97700)				3.39	III	22300 (99100)						4E18DA
1.30	42700 (4830)		0.97	-	9620 (42800)	1.57	35400 (4000)		1.17	I	12100 (53600)	1	4C14DB	1117			
			1.07	I	9620 (42800)				1.29	I	12100 (53600)						4C16DA
			1.48	II	19200 (85200)				1.79	II	20100 (89500)						4D16DA
			1.81	II	19200 (85200)				2.02	III	20100 (89500)						4D17DA
			2.02	III	21600 (96300)				2.02	III	22000 (97900)						4E17DA
			2.22	III	21600 (96300)				2.68	III	22000 (97900)						4E17DB
			2.40	III	21600 (96300)				2.90	III	22000 (97900)						4E18DA
1.10	50500 (5700)		0.82	-	5090 (22600)	1.33	41800 (4730)		0.99	-	9970 (44400)	1	4C14DB	1320			
			1.25	I	17800 (79400)				1.51	II	19300 (85800)						4D16DA
			1.53	II	17800 (79400)				1.85	II	19300 (85800)						4D17DA
			1.88	II	21200 (94500)				2.02	III	21700 (96500)						4E17DA
			2.03	III	21200 (94500)				2.45	III	21700 (96500)						4E18DA
0.876	63300 (7160)		1.00	I	14800 (66000)	1.06	52500 (5930)		1.21	I	17500 (77600)	1	4D16DA	1656			
			1.22	I	14800 (66000)				1.47	II	17500 (77600)						4D17DA
			1.50	II	20600 (91600)				1.81	II	21100 (94100)						4E17DA
			1.62	II	20600 (91600)				1.96	II	21100 (94100)						4E18DA
			2.38	III	29400 (131000)				2.87	III	29900 (133000)						4F18DA
			2.43	III	29400 (131000)				2.93	III	29900 (133000)						4F19DA

Notes: [1] For Y4 Double Reductions (4XXXDX) refer to the above table; for Y4 single reduction refer to tables on pages 2.91-2.130.

[2] Variable Frequency Drive (VFD) notes (see page 2.8 for Constant Torque Speed Ranges):

All 1HP+ motors require EP suffix in model number and can be used with a VFD, unless noted.

# Standard Mounting Selection Tables

**1 HP**  
(0.75 kW)

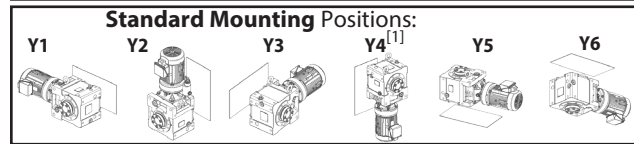

Dimension Pages:  
Single Reduction 2.132-2.143  
Single Reduction, Y2 2.144  
Double Reduction 2.146-2.161  
Double Reduction, Y2 2.162

Frequency	50 Hz	60 Hz
Input Speed	1450 RPM	1750 RPM
Number of Poles	4	

50Hz					60 Hz					Selection			VFD <sup>[2]</sup>		
Output Speed (RPM)	Output Torque		Service Factor		Solid Shaft Overhung Load		Output Speed (RPM)	Output Torque		Service Factor		Base			
	in-lbs	(N·m)	SF	AGMA Class	lbs	(N)		in-lbs	(N·m)	SF	AGMA Class	lbs	(N)	Motor Power Code	Frame Size
0.741	74800 (8460)		0.85	-	10700 (47400)	0.894	62000 (7010)	1.02	I	15200 (67700)	1	<b>4D16DA</b>	1957		
			1.03	I	10700 (47400)			1	<b>4D17DA</b>	1957					
			1.27	I	20000 (89000)			1	<b>4E17DA</b>	1957					
			1.37	I	20000 (89000)			1	<b>4E18DA</b>	1957					
			2.01	III	28900 (129000)			1	<b>4F18DA</b>	1957					
			2.06	III	28900 (129000)			1	<b>4F19DA</b>	1957					
0.638	86900 (9820)		1.09	I	19400 (86300)	0.770	72000 (8130)	1.32	I	20200 (89700)	1	<b>4E17DA</b>	2272		
			1.18	I	19400 (86300)			1	<b>4E18DA</b>	2272					
			1.73	II	28400 (126000)			1	<b>4F18DA</b>	2272					
			1.77	II	28400 (126000)			1	<b>4F19DA</b>	2272					
0.567	97900 (11100)		0.97	-	18300 (81500)	0.684	81100 (9160)	1.17	I	19700 (87600)	1	<b>4E17DA</b>	2559		
			1.05	I	18300 (81500)			1	<b>4E18DA</b>	2559					
			1.54	II	27900 (124000)			1	<b>4F18DA</b>	2559					
			1.57	II	27900 (124000)			1	<b>4F19DA</b>	2559					
0.493	113000 (12700)		0.84	-	13600 (60500)	0.595	93300 (10500)	1.02	I	19100 (84900)	1	<b>4E17DA</b>	2944		
			0.91	-	13600 (60500)			1	<b>4E18DA</b>	2944					
			1.34	I	27300 (121000)			1	<b>4F18DA</b>	2944					
			1.37	I	27300 (121000)			1	<b>4F19DA</b>	2944					
0.413	134000 (15200)		1.12	I	26400 (117000)	0.499	111000 (12600)	1.35	I	27400 (122000)	1	<b>4F18DA</b>	3511		
			1.15	I	26400 (117000)			1	<b>4F19DA</b>	3511					
0.332	167000 (18900)		0.90	-	25000 (111000)	0.401	138000 (15600)	1.09	I	26200 (116000)	1	<b>4F18DA</b>	4365		
			0.92	-	25000 (111000)			1	<b>4F19DA</b>	4365					

# Standard Mounting Selection Tables

**1.5 HP**  
(1.1 kW)

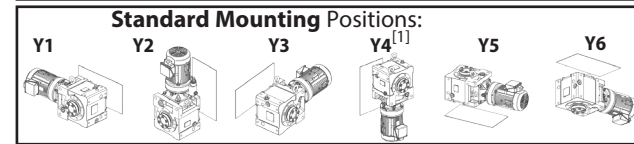

Dimension Pages:  
Single Reduction 2.132-2.143  
Single Reduction, Y2 2.144  
Double Reduction 2.146-2.161  
Double Reduction, Y2 2.162

Frequency	50 Hz	60 Hz
Input Speed	1450 RPM	1750 RPM
Number of Poles	4	

50Hz					60 Hz					Selection			VFD <sup>[2]</sup>	
Output Speed (RPM)	Output Torque		Service Factor		Solid Shaft Overhung Load		Output Speed (RPM)	Output Torque		Service Factor		Base		
	in-lbs	(N·m)	SF	AGMA Class	lbs	(N)		in-lbs	(N·m)	SF	AGMA Class	lbs	(N)	Motor Power Code
138	621 (70)		2.13	III	4010 (17800)	167	514 (58)	2.13	III	3800 (16900)	1H	<b>4A100</b>	11	
			2.89	III	4010 (17800)			2.89	III	3800 (16900)	1H	<b>4A105</b>	11	
113	757 (86)		2.13	III	4240 (18900)	137	627 (71)	2.13	III	4020 (17900)	1H	<b>4A100</b>	13	
			2.89	III	4240 (18900)			2.89	III	4020 (17900)	1H	<b>4A105</b>	13	
104	828 (94)		2.13	III	4350 (19400)	125	686 (78)	2.13	III	4130 (18400)	1H	<b>4A100</b>	14	
			2.89	III	4350 (19400)			2.89	III	4130 (18400)	1H	<b>4A105</b>	14	
90.6	946 (107)		2.13	III	4520 (20100)	109	784 (89)	2.13	III	4280 (19100)	1H	<b>4A100</b>	16	
			2.89	III	4520 (20100)			2.89	III	4280 (19100)	1H	<b>4A105</b>	16	
82.9	1030 (117)		2.13	III	4630 (20600)	100.0	857 (97)	2.13	III	4390 (19500)	1H	<b>4A100</b>	18	
			2.89	III	4630 (20600)			2.89	III	4390 (19500)	1H	<b>4A105</b>	18	
69.0	1240 (140)		2.14	III	4870 (21700)	83.3	1030 (116)	2.14	III	4620 (20600)	1H	<b>4A100</b>	21	
			2.89	III	4870 (21700)			2.89	III	4620 (20600)	1H	<b>4A105</b>	21	
51.8	1660 (187)		2.14	III	5270 (23400)	62.5	1370 (155)	2.14	III	5010 (22300)	1H	<b>4A100</b>	28	
			2.89	III	5270 (23400)			2.89	III	5010 (22300)	1H	<b>4A105</b>	28	
41.2	2080 (235)		2.14	III	5600 (24900)	49.7	1720 (195)	2.14	III	5330 (23700)	1H	<b>4A100</b>	35	
			2.89	III	5600 (24900)			2.89	III	5330 (23700)	1H	<b>4A105</b>	35	
37.7	2280 (257)		2.14	III	5740 (25500)	45.5	1890 (213)	2.14	III	5460 (24300)	1H	<b>4A100</b>	39	
			2.89	III	5740 (25500)			2.89	III	5460 (24300)	1H	<b>4A105</b>	39	
31.9	2690 (304)		2.14	III	5990 (26600)	38.5	2230 (252)	2.14	III	5700 (25400)	1H	<b>4A100</b>	46	
			2.89	III	5990 (26600)			2.89	III	5700 (25400)	1H	<b>4A105</b>	46	
27.6	3100 (351)		2.14	III	5980 (26600)	33.3	2570 (291)	2.14	III	5920 (26300)	1H	<b>4A100</b>	53	
			2.89	III	5980 (26600)			2.89	III	5920 (26300)	1H	<b>4A105</b>	53	
24.4	3520 (397)		1.81	II	5930 (26400)	29.4	2910 (329)	1.81	II	6000 (26700)	1H	<b>4A100</b>	60	
			2.24	III	5930 (26400)			2.24	III	6000 (26700)	1H	<b>4A105</b>	60	
			2.89	III	5930 (26400)			2.89	III	6000 (26700)	1H	<b>4A110</b>	60	
21.6	3970 (449)		1.73	II	5870 (26100)	26.0	3290 (372)	1.75	II	5960 (26500)	1H	<b>4A100</b>	67	
			2.08	III	5870 (26100)			2.13	III	5960 (26500)	1H	<b>4A105</b>	67	
			2.47	III	5870 (26100)			2.47	III	5960 (26500)	1H	<b>4A110</b>	67	
			2.83	III	5870 (26100)			2.83	III	5960 (26500)	1H	<b>4A115</b>	67	
			2.87	III	5870 (26100)			2.87	III	5960 (26500)	1H	<b>4A120</b>	67	
19.7	4350 (491)		1.73	II	5810 (25900)	23.8	3600 (407)	1.75	II	5920 (26300)	1H	<b>4A100</b>	74	
			2.08	III	5810 (25900)			2.13	III	5920 (26300)	1H	<b>4A105</b>	74	
			2.47	III	5810 (25900)			2.47	III	5920 (26300)	1H	<b>4A110</b>	74	
			2.63	III	5810 (25900)			2.63	III	5920 (26300)	1H	<b>4A120</b>	74	

Notes: [1] For Y4 Double Reductions (4XXXDX) refer to the above table; for Y4 single reduction refer to tables on pages 2.91-2.130.

[2] Variable Frequency Drive (VFD) notes (see page 2.8 for Constant Torque Speed Ranges):

All 1HP+ motors require EP suffix in model number and can be used with a VFD, unless noted.

Notes: [1] For Y4 Double Reductions (4XXXDX) refer to the above table; for Y4 single reduction refer to tables on pages 2.91-2.130..

[2] Variable Frequency Drive (VFD) notes (see page 2.8 for Constant Torque Speed Ranges):

All 1HP+ motors require EP suffix in model number and can be used with a VFD, unless noted.



# Standard Mounting Selection Tables

**1.5 HP**  
(1.1 kW)

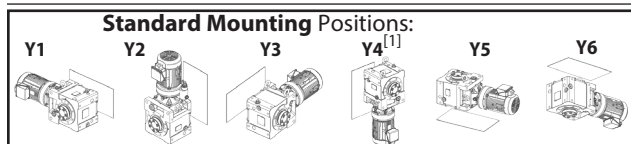

Dimension Pages:  
Single Reduction 2.132-2.143  
Single Reduction, Y2 2.144  
Double Reduction 2.146-2.161  
Double Reduction, Y2 2.162

Frequency	50 Hz	60 Hz
Input Speed	1450 RPM	1750 RPM
Number of Poles	4	

50Hz					60 Hz					Selection							
Output Speed (RPM)	Output Torque		Service Factor		Solid Shaft Overhung Load		Output Speed (RPM)	Output Torque		Service Factor		Solid Shaft Overhung Load		Base			VFD <sup>[2]</sup>
	in-lbs	(N·m)	SF	AGMA Class	lbs	(N)		in-lbs	(N·m)	SF	AGMA Class	lbs	(N)	Motor Power Code	Frame Size	Ratio	
18.1	4730	(534)	1.15	I	5750	(25600)	21.9	3920	(443)	1.15	I	5880	(26100)	1H	<b>4A100</b>	80	
			1.52	II	5750	(25600)				1.52	II	5880	(26100)	1H	<b>4A105</b>	80	
			1.74	II	5750	(25600)				1.74	II	5880	(26100)	1H	<b>4A110</b>	80	
			2.02	III	5750	(25600)				2.02	III	5880	(26100)	1H	<b>4A115</b>	80	
			2.41	III	5750	(25600)				2.41	III	5880	(26100)	1H	<b>4A120</b>	80	
			2.81	III	9650	(42900)				2.81	III	9180	(40800)	1H	<b>4B120</b>	80	
16.6	5170	(584)	1.15	I	5660	(25200)	20.0	4290	(484)	1.15	I	5820	(25900)	1H	<b>4A100</b>	88	
			1.52	II	5660	(25200)				1.52	II	5820	(25900)	1H	<b>4A105</b>	88	
			1.74	II	5660	(25200)				1.74	II	5820	(25900)	1H	<b>4A110</b>	88	
			2.02	III	5660	(25200)				2.02	III	5820	(25900)	1H	<b>4A115</b>	88	
			2.21	III	5660	(25200)				2.21	III	5820	(25900)	1H	<b>4A120</b>	88	
			2.81	III	9870	(43900)				2.81	III	9400	(41800)	1H	<b>4B120</b>	88	
14.3	6000	(678)	1.10	I	5490	(24400)	17.2	4970	(562)	1.10	I	5700	(25400)	1H	<b>4A100</b>	102	
			1.45	II	5490	(24400)				1.45	II	5700	(25400)	1H	<b>4A105</b>	102	
			1.73	II	5490	(24400)				1.73	II	5700	(25400)	1H	<b>4A110</b>	102	
			1.90	II	5490	(24400)				1.90	II	5700	(25400)	1H	<b>4A115</b>	102	
			2.61	III	9810	(43600)				2.72	III	9770	(43500)	1H	<b>4B120</b>	102	
			2.61	III	9810	(43600)				2.72	III	9770	(43500)	1H	<b>4B120</b>	102	
12.9	6620	(748)	0.89	-	5330	(23700)	15.6	5490	(620)	0.89	-	5600	(24900)	1H	<b>4A100</b>	112	
			1.09	I	5330	(23700)				1.09	I	5600	(24900)	1H	<b>4A105</b>	112	
			1.36	I	5330	(23700)				1.36	I	5600	(24900)	1H	<b>4A110</b>	112	
			1.65	II	5330	(23700)				1.65	II	5600	(24900)	1H	<b>4A115</b>	112	
			1.72	II	5330	(23700)				1.72	II	5600	(24900)	1H	<b>4A120</b>	112	
			2.16	III	9760	(43400)				2.26	III	9850	(43800)	1H	<b>4B120</b>	112	
			2.61	III	9760	(43400)				2.89	III	9850	(43800)	1H	<b>4B125</b>	112	
			2.61	III	9760	(43400)				2.89	III	9850	(43800)	1H	<b>4B125</b>	112	
11.8	7240	(818)	0.89	-	5150	(22900)	14.3	6000	(678)	0.89	-	5490	(24400)	1H	<b>4A100</b>	123	
			1.09	I	5150	(22900)				1.09	I	5490	(24400)	1H	<b>4A105</b>	123	
			1.36	I	5150	(22900)				1.36	I	5490	(24400)	1H	<b>4A110</b>	123	
			1.58	II	5150	(22900)				1.58	II	5490	(24400)	1H	<b>4A115</b>	123	
			2.16	III	9700	(43100)				2.26	III	9810	(43600)	1H	<b>4B120</b>	123	
			2.61	III	9700	(43100)				2.89	III	9810	(43600)	1H	<b>4B125</b>	123	
9.63	8900	(1010)	0.98	-	4560	(20300)	11.6	7370	(833)	0.98	-	5110	(22700)	1H	<b>4A105</b>	151	
			1.18	I	4560	(20300)				1.18	I	5110	(22700)	1H	<b>4A110</b>	151	
			1.28	I	4560	(20300)				1.28	I	5110	(22700)	1H	<b>4A115</b>	151	
			1.74	II	9510	(42300)				1.74	II	9680	(43100)	1H	<b>4B120</b>	151	
			2.13	III	9510	(42300)				2.16	III	9680	(43100)	1H	<b>4B125</b>	151	
			2.56	III	9510	(42300)				2.56	III	9680	(43100)	1H	<b>4B140</b>	151	

# Standard Mounting Selection Tables

**1.5 HP**  
(1.1 kW)

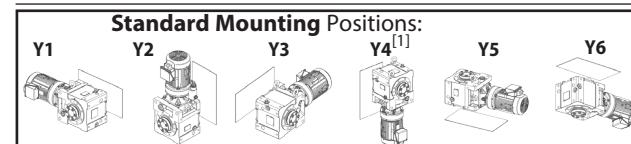

Dimension Pages:  
Single Reduction 2.132-2.143  
Single Reduction, Y2 2.144  
Double Reduction 2.146-2.161  
Double Reduction, Y2 2.162

Frequency	50 Hz	60 Hz
Input Speed	1450 RPM	1750 RPM
Number of Poles	4	

50Hz					60 Hz					Selection							
Output Speed (RPM)	Output Torque		Service Factor		Solid Shaft Overhung Load		Output Speed (RPM)	Output Torque		Service Factor		Solid Shaft Overhung Load		Base			VFD <sup>[2]</sup>
	in-lbs	(N·m)	SF	AGMA Class	lbs	(N)		in-lbs	(N·m)	SF	AGMA Class	lbs	(N)	Motor Power Code	Frame Size	Ratio	
8.12	10600	(1190)	1.01	I	3720	(16600)	9.80	8740	(988)	1.01	I	4620	(20600)	1H	<b>4A115</b>	179	
			1.08	I	3720	(16600)				1.08	I	4620	(20600)	1H	<b>4A120</b>	179	
			1.48	II	9290	(41300)				1.56	II	9530	(42400)	1H	<b>4B120</b>	179	
			1.79	II	9290	(41300)				2.07	III	9530	(42400)	1H	<b>4B125</b>	179	
			2.16	III	9290	(41300)				2.16	III	9530	(42400)	1H	<b>4B140</b>	179	
			2.16	III	9290	(41300)				2.16	III	9530	(42400)	1H	<b>4B140</b>	179	
7.02	12200	(1380)	0.92	-	2400	(10700)	8.47	10100	(1140)	0.92	-	3980	(17700)	1H	<b>4A115</b>	207	
			0.94	-	2400	(10700)				0.94	-	3980	(17700)	1H	<b>4A125</b>	207	
			1.18	I	9020	(40100)				1.18	I	9350	(41600)	1H	<b>4B120</b>	207	
			1.47	II	9020	(40100)				1.47	II	9350	(41600)	1H	<b>4B125</b>	207	
			1.86	II	9020	(40100)				1.86	II	9350	(41600)	1H	<b>4B145</b>	207	
			2.69	III	15800	(70100)				2.69	III	15900	(70600)	1H	<b>4C140</b>	207	
			2.89	III	15800	(70100)				3.32	III	15900	(70600)	1H	<b>4C145</b>	207	
			3.32	III	15800	(70100)				3.32	III	15900	(70600)	1H	<b>4C145</b>	207	
5.84	14700	(1660)	1.03	I	8510	(37900)	7.04	12200	(1380)	1.03	I	9020	(40100)	1H	<b>4B125</b>	249	
			1.55	II	8510	(37900)				1.55	II	9020	(40100)	1H	<b>4B145</b>	249	
			2.21	III	15600	(69300)				2.21	III	15800	(70100)	1H	<b>4C140</b>	249	
			2.38	III	15600	(69300)				2.75	III	15800	(70100)	1H	<b>4C145</b>	249	
			2.38	III	15600	(69300)				2.75	III	15800	(70100)	1H	<b>4C145</b>	249	
			2.38	III	15600	(69300)				2.75	III	15800	(70100)	1H	<b>4C145</b>	249	
4.76	18000	(2030)	0.93	-	7630	(33900)	5.75	14900	(1690)	0.93	-	8460	(37600)	1H	<b>4B125</b>	305	
			1.26	I	7630	(33900)				1.26	I	8460	(37600)	1H	<b>4B145</b>	305	
			1.80	II	15300	(68000)				1.80	II	15600	(69200)	1H	<b>4C140</b>	305	
			1.96	II	15300	(68000)				2.25	III	15600	(69200)	1H	<b>4C145</b>	305	
			2.46	III	15300	(68000)				2.53	III	15600	(69200)	1H	<b>4C160</b>	305	
			2.46	III	15300	(68000)				2.53	III	15600	(69200)	1H	<b>4C160</b>	305	
3.98	20400	(2310)	0.93	-	6320	(28100)	4.81	16900	(1910)	0.93	-	7680	(34200)	1H	<b>4B12DB</b>	364	
			1.11	I	6320	(28100)				1.34	I	7680	(34200)	1H	<b>4B14DB</b>	364	
			1.38	I	14900	(66300)				1.38	I	15300	(68100)	1H	<b>4C14DB</b>	364	
			2.02	III	14900	(66300)				2.44	III	15300	(68100)	1H	<b>4C14DC</b>	364	
			2.23	III	14900	(66300)				2.69	III	15300	(68100)	1H	<b>4C16DB</b>	364	
			2.23	III	14900	(66300)				2.69	III	15300	(68100)	1H	<b>4C16DB</b>	364	
3.42	23800	(2680)	0.96	-	4280	(19000)	4.13	19700	(2220)	0.96	-	6650	(29600)	1H	<b>4B14DB</b>	424	
			1.38	I	14400	(64200)				1.38	I	15000	(66700)	1H	<b>4C14DB</b>	424	
			1.64	II	14400	(64200)				1.98	II	15000	(66700)	1H	<b>4C14DC</b>	424	
			1.91	II	14400	(64200)				2.31	III	15000	(66700)	1H	<b>4C16DB</b>	424	
			2.66	III	21200	(94500)				2.89	III	21500	(95700)	1H	<b>4D16DB</b>	424	
			2.89	III	21200	(94500)				2.89	III	21500	(95700)	1H	<b>4D17DB</b>	424	
2.90	28100	(3170)	1.38	I	13700	(61000)	3.50	23300	(2630)	1.38	I	14500	(64600)	1H	<b>4C14DB</b>	501	
			1.62	II	13700	(61000)				1.96	II	14500	(64600)	1H	<b>4C16DB</b>	501	
			2.25	III	20900	(92900)				2.72	III	21300	(94600)	1H	<b>4D16DB</b>	501	
			2.89	III	22400	(99600)				2.89	III	22600	(101000)	1H	<b>4E17DB</b>	501	
			2.89	III	22400	(99600)				2.89	III	22600	(101000)	1H	<b>4E17DB</b>	501	
			2.89	III	22400	(99600)				2.89	III	22600	(101000)	1H	<b>4E17DB</b>	501	

Notes: [1] For Y4 Double Reductions (4XXXDX) refer to the above table; for Y4 single reduction refer to tables on pages 2.91-2.130.

[2] Variable Frequency Drive (VFD) notes (see page 2.8 for Constant Torque Speed Ranges):

All 1HP+ motors require EP suffix in model number and can be used with a VFD, unless noted.

Notes: [1] For Y4 Double Reductions (4XXXDX) refer to the above table; for Y4 single reduction refer to tables on pages 2.91-2.130.

[2] Variable Frequency Drive (VFD) notes (see page 2.8 for Constant Torque Speed Ranges):

# Standard Mounting Selection Tables

**1.5 HP  
(1.1 kW)**

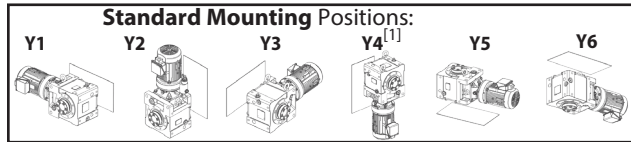

Dimension Pages:  
Single Reduction 2.132-2.143  
Single Reduction, Y2 2.144  
Double Reduction 2.146-2.161  
Double Reduction, Y2 2.162

Frequency	50 Hz	60 Hz
Input Speed	1450 RPM	1750 RPM
Number of Poles	4	

50Hz					60 Hz					Selection								
Output Speed (RPM)	Output Torque		Service Factor		Solid Shaft Overhung Load		Output Speed (RPM)	Output Torque		Service Factor		Solid Shaft Overhung Load		Base			VFD <sup>[2]</sup>	
	in-lbs	(N·m)	SF	AGMA Class	lbs	(N)		in-lbs	(N·m)	SF	AGMA Class	lbs	(N)	Motor Power Code	Frame Size	Ratio		
2.51	32400 (3660)		1.26	I	12800 (56900)	3.03	26800 (3030)		1.38	I	13900 (62000)	1H	4C14DB	578				
			1.38	I	12800 (56900)				1.38	I	13900 (62000)						4C16DA	578
			1.95	II	20500 (91000)				2.36	III	21000 (93400)						4D16DB	578
			2.38	III	20500 (91000)				2.87	III	21000 (93400)						4D17DB	578
			2.89	III	22200 (98600)				2.89	III	22400 (99800)						4E17DB	578
			2.12	38300 (4330)					1.07	I	11200 (49800)						2.56	31700 (3580)
1.19	I	11200 (49800)	1.38			I	13000 (57600)	4C16DA	683									
1.38	I	19800 (87900)	1.38			I	20500 (91300)	4D16DA	683									
1.65	II	19800 (87900)	1.99			II	20500 (91300)	4D16DB	683									
2.02	III	19800 (87900)	2.43			III	20500 (91300)	4D17DB	683									
2.48	III	21900 (97300)	2.89			III	22200 (98700)	4E17DB	683									
1.79	45400 (5130)		0.89	-	8430 (37500)	2.16	37600 (4250)		1.07	I	11400 (50800)	1H	4C14DB	809				
			1.00	I	8430 (37500)				1.21	I	11400 (50800)						4C16DA	809
			1.38	I	18700 (83400)				1.38	I	19900 (88300)						4D16DA	809
			1.70	II	18700 (83400)				2.05	III	19900 (88300)						4D17DB	809
			2.09	III	21500 (95700)				2.52	III	21900 (97400)						4E17DB	809
			2.26	III	21500 (95700)				2.73	III	21900 (97400)						4E18DA	809
1.52	53600 (6060)		1.18	I	17200 (76600)	1.83	44400 (5020)		1.38	I	18900 (84000)	1H	4D16DA	956				
			1.38	I	17200 (76600)				1.38	I	18900 (84000)						4D17DA	956
			1.44	II	17200 (76600)				1.74	II	18900 (84000)						4D17DB	956
			1.77	II	21100 (93800)				2.14	III	21600 (95900)						4E17DB	956
			1.92	II	21100 (93800)				2.31	III	21600 (95900)						4E18DA	956
			2.81	III	29900 (133000)				2.89	III	30200 (135000)						4F18DA	956
1.30	62600 (7080)		1.01	I	15000 (66900)	1.57	51900 (5860)		1.22	I	17600 (78100)	1H	4D16DA	1117				
			1.23	I	15000 (66900)				1.38	I	17600 (78100)						4D17DA	1117
			1.38	I	20600 (91800)				1.38	I	21200 (94200)						4E17DA	1117
			1.51	II	20600 (91800)				1.83	II	21200 (94200)						4E17DB	1117
			1.64	II	20600 (91800)				1.98	II	21200 (94200)						4E18DA	1117
			2.40	III	29500 (131000)				2.89	III	29900 (133000)						4F18DA	1117

Notes: [1] For Y4 Double Reductions (4XXXDX) refer to the above table; for Y4 single reduction refer to tables on pages 2.91-2.130.  
[2] Variable Frequency Drive (VFD) notes (see page 2.8 for Constant Torque Speed Ranges):  
All 1HP+ motors require EP suffix in model number and can be used with a VFD, unless noted.

# Standard Mounting Selection Tables

**1.5 HP  
(1.1 kW)**

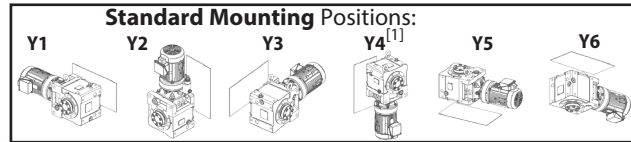

Dimension Pages:  
Single Reduction 2.132-2.143  
Single Reduction, Y2 2.144  
Double Reduction 2.146-2.161  
Double Reduction, Y2 2.162

Frequency	50 Hz	60 Hz
Input Speed	1450 RPM	1750 RPM
Number of Poles	4	

50Hz					60 Hz					Selection								
Output Speed (RPM)	Output Torque		Service Factor		Solid Shaft Overhung Load		Output Speed (RPM)	Output Torque		Service Factor		Solid Shaft Overhung Load		Base			VFD <sup>[2]</sup>	
	in-lbs	(N·m)	SF	AGMA Class	lbs	(N)		in-lbs	(N·m)	SF	AGMA Class	lbs	(N)	Motor Power Code	Frame Size	Ratio		
1.10	74000 (8360)		0.85	-	11000 (49100)	1.33	61300 (6930)		1.03	I	15400 (68500)	1H	4D16DA	1320				
			1.04	I	11000 (49100)				1.26	I	15400 (68500)						4D17DA	1320
			1.28	I	20100 (89200)				1.38	I	20700 (92100)						4E17DA	1320
			1.39	I	20100 (89200)				1.67	II	20700 (92100)						4E18DA	1320
			2.03	III	29000 (129000)				2.45	III	29500 (131000)						4F18DA	1320
			2.08	III	29000 (129000)				2.51	III	29500 (131000)						4F19DA	1320
0.876	92900 (10500)		1.02	I	19100 (85000)	1.06	77000 (8700)		1.23	I	19900 (88500)	1H	4E17DA	1656				
			1.11	I	19100 (85000)				1.33	I	19900 (88500)						4E18DA	1656
			1.62	II	28200 (125000)				1.96	II	28800 (128000)						4F18DA	1656
			1.66	II	28200 (125000)				2.00	III	28800 (128000)						4F19DA	1656
0.741	110000 (12400)		0.86	-	14700 (65300)	0.894	91000 (10300)		1.04	I	19200 (85400)	1H	4E17DA	1957				
			0.94	-	14700 (65300)				1.13	I	19200 (85400)						4E18DA	1957
			1.37	I	27400 (122000)				1.66	II	28200 (126000)						4F18DA	1957
0.638	127000 (14400)		0.81	-	3570 (15900)	0.770	106000 (11900)		0.97	-	16100 (71600)	1H	4E18DA	2272				
			1.18	I	26700 (119000)				1.43	II	27600 (123000)						4F18DA	2272
			1.21	I	26700 (119000)				1.46	II	27600 (123000)						4F19DA	2272
0.567	144000 (16200)		1.05	I	26000 (115000)	0.684	119000 (13400)		1.27	I	27000 (120000)	1H	4F18DA	2559				
			1.07	I	26000 (115000)				1.29	I	27000 (120000)						4F19DA	2559
0.493	165000 (18700)		0.91	-	25000 (111000)	0.595	137000 (15500)		1.10	I	26300 (117000)	1H	4F18DA	2944				
			0.93	-	25000 (111000)				1.13	I	26300 (117000)						4F19DA	2944

Notes: [1] For Y4 Double Reductions (4XXXDX) refer to the above table; for Y4 single reduction refer to tables on pages 2.91-2.130.  
[2] Variable Frequency Drive (VFD) notes (see page 2.8 for Constant Torque Speed Ranges):  
All 1HP+ motors require EP suffix in model number and can be used with a VFD, unless noted.

# Standard Mounting Selection Tables

**2 HP  
(1.5 kW)**

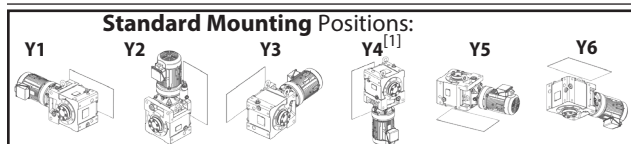

Dimension Pages:  
Single Reduction 2.132-2.143  
Single Reduction, Y2 2.144  
Double Reduction 2.146-2.161  
Double Reduction, Y2 2.162

Frequency	50 Hz	60 Hz
Input Speed	1450 RPM	1750 RPM
Number of Poles	4	

50Hz					60 Hz					Selection							
Output Speed (RPM)	Output Torque		Service Factor		Solid Shaft Overhung Load		Output Speed (RPM)	Output Torque		Service Factor		Solid Shaft Overhung Load		Base			VFD <sup>[2]</sup>
	in-lbs	(N·m)	SF	AGMA Class	lbs	(N)		in-lbs	(N·m)	SF	AGMA Class	lbs	(N)	Motor Power Code	Frame Size	Ratio	
138	847	(96)	1.56	II	3980	(17700)	167	701	(79)	1.56	II	3770	(16800)	2	4A100	11	
			2.12	III	3980	(17700)				2.12	III	3770	(16800)				
113	1030	(117)	1.56	II	4200	(18700)	137	855	(97)	1.56	II	3990	(17800)	2	4A100	13	
			2.12	III	4200	(18700)				2.12	III	3990	(17800)				
104	1130	(128)	1.56	II	4310	(19200)	125	935	(106)	1.56	II	4090	(18200)	2	4A100	14	
			2.12	III	4310	(19200)				2.12	III	4090	(18200)				
90.6	1290	(146)	1.56	II	4470	(19900)	109	1070	(121)	1.56	II	4250	(18900)	2	4A100	16	
			2.12	III	4470	(19900)				2.12	III	4250	(18900)				
82.9	1410	(159)	1.56	II	4580	(20400)	100.0	1170	(132)	1.56	II	4350	(19400)	2	4A100	18	
			2.12	III	4580	(20400)				2.12	III	4350	(19400)				
69.0	1690	(191)	1.57	II	4810	(21400)	83.3	1400	(158)	1.57	II	4570	(20300)	2	4A100	21	
			2.12	III	4810	(21400)				2.12	III	4570	(20300)				
			2.61	III	4810	(21400)				2.61	III	4570	(20300)				
			2.61	III	4810	(21400)				2.61	III	4570	(20300)				
51.8	2260	(255)	1.57	II	5190	(23100)	62.5	1870	(211)	1.57	II	4940	(22000)	2	4A100	28	
			2.12	III	5190	(23100)				2.12	III	4940	(22000)				
			2.61	III	5190	(23100)				2.61	III	4940	(22000)				
41.2	2840	(321)	1.57	II	5500	(24500)	49.7	2350	(266)	1.57	II	5240	(23300)	2	4A100	35	
			2.12	III	5500	(24500)				2.12	III	5240	(23300)				
			2.61	III	5500	(24500)				2.61	III	5240	(23300)				
			2.61	III	5500	(24500)				2.61	III	5240	(23300)				
37.7	3100	(351)	1.57	II	5620	(25000)	45.5	2570	(291)	1.57	II	5360	(23900)	2	4A100	39	
			2.12	III	5620	(25000)				2.12	III	5360	(23900)				
			2.61	III	5620	(25000)				2.61	III	5360	(23900)				
31.9	3670	(414)	1.57	II	5860	(26000)	38.5	3040	(343)	1.57	II	5590	(24900)	2	4A100	46	
			2.12	III	5860	(26000)				2.12	III	5590	(24900)				
			2.60	III	5860	(26000)				2.60	III	5590	(24900)				
27.6	4230	(478)	1.57	II	5830	(25900)	33.3	3510	(396)	1.57	II	5790	(25800)	2	4A100	53	
			2.12	III	5830	(25900)				2.12	III	5790	(25800)				
			2.60	III	5830	(25900)				2.60	III	5790	(25800)				
			2.70	III	5830	(25900)				2.70	III	5790	(25800)				
			2.70	III	5830	(25900)				2.70	III	5790	(25800)				
24.4	4800	(542)	1.33	I	5740	(25500)	29.4	3970	(449)	1.33	I	5870	(26100)	2	4A100	60	
			1.64	II	5740	(25500)				1.64	II	5870	(26100)				
			2.38	III	5740	(25500)				2.38	III	5870	(26100)				
21.6	5420	(612)	1.27	I	5610	(25000)	26.0	4490	(507)	1.29	I	5790	(25700)	2	4A100	67	
			1.52	II	5610	(25000)				1.56	II	5790	(25700)				
			2.07	III	5610	(25000)				2.07	III	5790	(25700)				
			2.11	III	5610	(25000)				2.11	III	5790	(25700)				
			2.64	III	9050	(40300)				2.64	III	8630	(38400)				
			2.64	III	9050	(40300)				2.64	III	8630	(38400)				

# Standard Mounting Selection Tables

**2 HP  
(1.5 kW)**

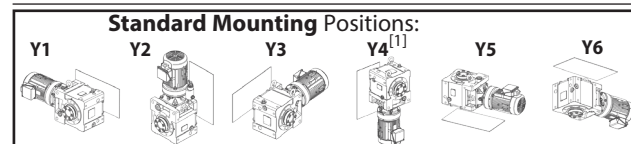

Dimension Pages:  
Single Reduction 2.132-2.143  
Single Reduction, Y2 2.144  
Double Reduction 2.146-2.161  
Double Reduction, Y2 2.162

Frequency	50 Hz	60 Hz
Input Speed	1450 RPM	1750 RPM
Number of Poles	4	

50Hz					60 Hz					Selection							
Output Speed (RPM)	Output Torque		Service Factor		Solid Shaft Overhung Load		Output Speed (RPM)	Output Torque		Service Factor		Solid Shaft Overhung Load		Base			VFD <sup>[2]</sup>
	in-lbs	(N·m)	SF	AGMA Class	lbs	(N)		in-lbs	(N·m)	SF	AGMA Class	lbs	(N)	Motor Power Code	Frame Size	Ratio	
19.7	5930	(669)	1.27	I	5500	(24500)	23.8	4910	(555)	1.29	I	5710	(25400)	2	4A100	74	
			1.52	II	5500	(24500)				1.56	II	5710	(25400)				
			1.93	II	5500	(24500)				1.93	II	5710	(25400)				
			2.64	III	9260	(41200)				2.64	III	8830	(39300)				
18.1	6450	(729)	1.11	I	5370	(23900)	21.9	5340	(604)	1.11	I	5630	(25000)	2	4A100	80	
			1.48	II	5370	(23900)				1.48	II	5630	(25000)				
			1.77	II	5370	(23900)				1.77	II	5630	(25000)				
			2.06	III	9460	(42100)				2.06	III	9020	(40100)				
			2.64	III	9460	(42100)				2.64	III	9020	(40100)				
16.6	7050	(797)	1.11	I	5210	(23200)	20.0	5840	(660)	1.11	I	5520	(24600)	2	4A100	88	
			1.48	II	5210	(23200)				1.48	II	5520	(24600)				
			1.62	II	5210	(23200)				1.62	II	5520	(24600)				
			2.06	III	9670	(43000)				2.06	III	9230	(41100)				
			2.64	III	9670	(43000)				2.64	III	9230	(41100)				
14.3	8180	(925)	1.06	I	4840	(21500)	17.2	6780	(766)	1.06	I	5290	(23500)	2	4A100	102	
			1.40	II	4840	(21500)				1.40	II	5290	(23500)				
			1.91	II	9600	(42700)				1.99	II	9580	(42600)				
			2.31	III	9600	(42700)				2.51	III	9580	(42600)				
			2.78	III	9600	(42700)				2.78	III	9580	(42600)				
12.9	9030	(1020)	1.00	I	4500	(20000)	15.6	7480	(845)	1.00	I	5080	(22600)	2	4A110	112	
			1.26	I	4500	(20000)				1.26	I	5080	(22600)				
			1.58	II	9500	(42200)				1.66	II	9670	(43000)				
			1.92	II	9500	(42200)				2.12	III	9670	(43000)				
			2.52	III	9500	(42200)				2.52	III	9670	(43000)				
11.8	9880	(1120)	0.80	-	4100	(18300)	14.3	8180	(925)	0.80	-	4840	(21500)	2	4A100	123	
			1.00	I	4100	(18300)				1.00	I	4840	(21500)				
			1.16	I	4100	(18300)				1.16	I	4840	(21500)				
			1.58	II	9390	(41800)				1.66	II	9600	(42700)				
			1.92	II	9390	(41800)				2.12	III	9600	(42700)				
			2.30	III	9390	(41800)				2.30	III	9600	(42700)				
9.63	12100	(1370)	0.94	-	2480	(11000)	11.6	10100	(1140)	0.94	-	4010	(17800)	2	4A115	151	
			1.27	I	9030	(40200)				1.27	I	9360	(41600)				
			1.56	II	9030	(40200)				1.59	II	9360	(41600)				
			1.87	II	9030	(40200)				1.87	II	9360	(41600)				
			2.63	III	15700	(69900)				2.63	III	15000	(66700)				
			2.63	III	15700	(69900)				2.63	III	15000	(66700)				

Notes: [1] For Y4 Double Reductions (4XXXDX) refer to the above table; for Y4 single reduction refer to tables on pages 2.91-2.130.

[2] Variable Frequency Drive (VFD) notes (see page 2.8 for Constant Torque Speed Ranges):

All 1HP+ motors require EP suffix in model number and can be used with a VFD, unless noted.

Notes: [1] For Y4 Double Reductions (4XXXDX) refer to the above table; for Y4 single reduction refer to tables on pages 2.91-2.130.

[2] Variable Frequency Drive (VFD) notes (see page 2.8 for Constant Torque Speed Ranges):

All 1HP+ motors require EP suffix in model number and can be used with a VFD, unless noted.

# Standard Mounting Selection Tables

**2 HP  
(1.5 kW)**

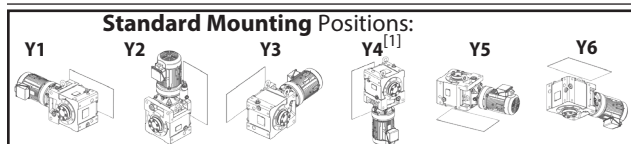

Dimension Pages:  
Single Reduction 2.132-2.143  
Single Reduction, Y2 2.144  
Double Reduction 2.146-2.161  
Double Reduction, Y2 2.162

Frequency	50 Hz	60 Hz
Input Speed	1450 RPM	1750 RPM
Number of Poles	4	

50Hz					60 Hz					Selection							
Output Speed (RPM)	Output Torque		Service Factor		Solid Shaft Overhung Load		Output Speed (RPM)	Output Torque		Service Factor		Solid Shaft Overhung Load		Base			VFD <sup>[2]</sup>
	in-lbs	(N·m)	SF	AGMA Class	lbs	(N)		in-lbs	(N·m)	SF	AGMA Class	lbs	(N)	Motor Power Code	Frame Size	Ratio	
8.12	14400 (1630)		1.09	I	8580 (38200)	9.80	11900 (1350)		1.15	I	9070 (40300)	2	4B120	179			
			1.32	I	8580 (38200)				1.52	II	9070 (40300)						4B125
			1.58	II	8580 (38200)				1.58	II	9070 (40300)						4B140
			2.29	III	15600 (69400)				2.29	III	15700 (69600)						4C140
			2.47	III	15600 (69400)				2.81	III	15700 (69600)						4C145
			7.02	16600 (1880)					1.08	I	8030 (35700)						8.47
1.37	I	8030 (35700)	1.37			I	8710 (38700)	4B140									
1.97	II	15400 (68600)	1.97			II	15600 (69600)	4C140									
2.12	III	15400 (68600)	2.43			III	15600 (69600)	4C145									
2.66	III	15400 (68600)	2.73			III	15600 (69600)	4C160									
2.95	III	21700 (96700)	2.95			III	21900 (97200)	4D160									
5.84	20000 (2260)		1.14	I	6930 (30800)	7.04	16600 (1880)		1.14	I	8040 (35800)	2	4B140	249			
			1.62	II	15100 (67100)				1.62	II	15400 (68600)						4C140
			1.75	II	15100 (67100)				2.02	III	15400 (68600)						4C145
			2.21	III	15100 (67100)				2.27	III	15400 (68600)						4C160
			2.31	III	21600 (95900)				2.31	III	21700 (96700)						4D160
			4.76	24500 (2770)					0.93	-	4640 (20600)						5.75
1.44	II	14500 (64500)	1.65			II	15000 (66900)	4C145									
1.81	II	14500 (64500)	1.85			II	15000 (66900)	4C160									
2.15	III	21300 (94600)	2.31			III	21500 (95800)	4D160									
2.51	III	21300 (94600)	2.60			III	21500 (95800)	4D165									
3.98	27800 (3150)		1.01			I	13800 (61200)	4.81	23100 (2610)		1.01	I	14500 (64700)	2	4C14DB	364	
1.48			II	13800 (61200)	1.79	II	14500 (64700)				4C14DC						
1.63			II	13800 (61200)	1.97	II	14500 (64700)				4C16DB						
2.12			III	20900 (93000)	2.12	III	21300 (94700)				4D16DB						
2.27			III	20900 (93000)	2.74	III	21300 (94700)				4D16DC						
2.77			III	20900 (93000)	3.34	III	21300 (94700)				4D17DC						
3.42	32400 (3660)		1.01	I	12800 (56900)	4.13	26800 (3030)		1.01	I	13900 (62000)	2	4C14DB	424			
			1.40	II	12800 (56900)				1.69	II	13900 (62000)						4C16DB
			1.95	II	20500 (91000)				2.12	III	21000 (93400)						4D16DB
			2.12	III	20500 (91000)				2.12	III	21000 (93400)						4D17DB
			2.93	III	22200 (98600)				3.53	III	22400 (99800)						4E17DC
			2.90	38300 (4330)					1.01	I	11200 (49800)						3.50
1.19	I	11200 (49800)	1.43			II	13000 (57600)	4C16DB									
1.65	II	19800 (87900)	1.99			II	20500 (91300)	4D16DB									
2.02	III	19800 (87900)	2.12			III	20500 (91300)	4D17DB									
2.48	III	21900 (97300)	2.99			III	22200 (98700)	4E17DC									
2.68	III	21900 (97300)	3.24			III	22200 (98700)	4E18DB									

Notes: [1] For Y4 Double Reductions (4XXXDX) refer to the above table; for Y4 single reduction refer to tables on pages 2.91-2.130.

[2] Variable Frequency Drive (VFD) notes (see page 2.8 for Constant Torque Speed Ranges):

All 1HP+ motors require EP suffix in model number and can be used with a VFD, unless noted.

# Standard Mounting Selection Tables

**2 HP  
(1.5 kW)**

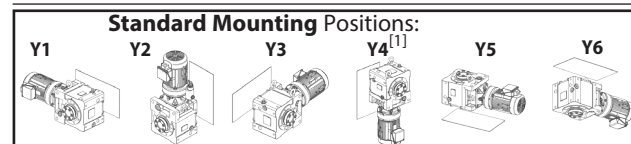

Dimension Pages:  
Single Reduction 2.132-2.143  
Single Reduction, Y2 2.144  
Double Reduction 2.146-2.161  
Double Reduction, Y2 2.162

Frequency	50 Hz	60 Hz
Input Speed	1450 RPM	1750 RPM
Number of Poles	4	

50Hz					60 Hz					Selection							
Output Speed (RPM)	Output Torque		Service Factor		Solid Shaft Overhung Load		Output Speed (RPM)	Output Torque		Service Factor		Solid Shaft Overhung Load		Base			VFD <sup>[2]</sup>
	in-lbs	(N·m)	SF	AGMA Class	lbs	(N)		in-lbs	(N·m)	SF	AGMA Class	lbs	(N)	Motor Power Code	Frame Size	Ratio	
2.51	44200 (4990)		0.93	-	8990 (40000)	3.03	36600 (4140)		1.01	I	11700 (52100)	2	4C14DB	578			
			1.01	I	8990 (40000)				1.01	I	11700 (52100)						4C16DA
			1.43	II	18900 (84200)				1.73	II	20000 (88900)						4D16DB
			1.75	II	18900 (84200)				2.11	III	20000 (88900)						4D17DB
			2.15	III	21600 (95900)				2.59	III	22000 (97600)						4E17DC
			2.32	III	21600 (95900)				2.80	III	22000 (97600)						4E18DB
2.12	52200 (5900)		0.87	-	3070 (13700)	2.56	43300 (4890)		1.01	I	9390 (41800)	2	4C16DA	683			
			1.01	I	17500 (77900)				1.01	I	19100 (84800)						4D16DA
			1.48	II	17500 (77900)				1.78	II	19100 (84800)						4D17DB
			1.82	II	21200 (94100)				2.12	III	21600 (96100)						4E17DB
			1.97	II	21200 (94100)				2.37	III	21600 (96100)						4E18DB
			2.84	III	29900 (133000)				3.43	III	30300 (135000)						4F18DB
1.79	61900 (6990)		1.01	I	15300 (67800)	2.16	51300 (5790)		1.01	I	17700 (78700)	2	4D16DA	809			
			1.25	I	15300 (67800)				1.51	II	17700 (78700)						4D17DB
			1.53	II	20700 (91900)				1.85	II	21200 (94300)						4E17DB
			1.66	II	20700 (91900)				2.00	III	21200 (94300)						4E18DA
			2.12	III	29500 (131000)				2.12	III	30000 (133000)						4F18DA
			2.43	III	29500 (131000)				2.94	III	30000 (133000)						4F18DB
1.52	73100 (8260)		0.87	-	11400 (50900)	1.83	60600 (6840)		1.01	I	15600 (69400)	2	4D16DA	956			
			1.01	I	11400 (50900)				1.01	I	15600 (69400)						4D17DA
			1.30	I	20100 (89400)				1.57	II	20700 (92200)						4E17DB
			1.40	II	20100 (89400)				1.69	II	20700 (92200)						4E18DA
			2.06	III	29000 (129000)				2.12	III	29500 (131000)						4F18DA
			2.06	III	29000 (129000)				2.49	III	29500 (131000)						4F18DB
1.30	85400 (9650)		0.90	-	272 (1210)	1.57	70800 (8000)		1.01	I	12400 (55100)	2	4D17DA	1117			
			1.01	I	19500 (86600)				1.01	I	20200 (89900)						4E17DA
			1.11	I	19500 (86600)				1.34	I	20200 (89900)						4E17DB
			1.20	I	19500 (86600)				1.45	II	20200 (89900)						4E18DA
			1.76	II	28500 (127000)				2.12	III	29100 (129000)						4F18DA
			1.76	II	28500 (127000)				2.13	III	29100 (129000)						4F18DB
1.10	101000 (11400)		0.94	-	17500 (77800)	1.33	83600 (9450)		1.01	I	19600 (87000)	2	4E17DA	1320			
			1.02	I	17500 (77800)				1.23	I	19600 (87000)						4E18DA
			1.49	II	27800 (124000)				1.80	II	28600 (127000)						4F18DA
			1.53	II	27800 (124000)				1.84	II	28600 (127000)						4F19DA

Notes: [1] For Y4 Double Reductions (4XXXDX) refer to the above table; for Y4 single reduction refer to tables on pages 2.91-2.130.

[2] Variable Frequency Drive (VFD) notes (see page 2.8 for Constant Torque Speed Ranges):

All 1HP+ motors require EP suffix in model number and can be used with a VFD, unless noted.



# Standard Mounting Selection Tables

**2 HP  
(1.5 kW)**

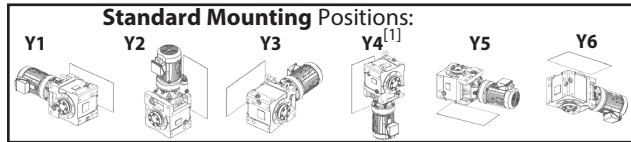

Dimension Pages:  
 Single Reduction, Y2 2.132-2.143  
 Single Reduction, Y2 2.144  
 Double Reduction 2.146-2.161  
 Double Reduction, Y2 2.162

Frequency	50 Hz	60 Hz
Input Speed	1450 RPM	1750 RPM
Number of Poles	4	

50Hz				60 Hz				Selection			VFD <sup>[2]</sup>			
Output Speed (RPM)	Output Torque		Service Factor	Solid Shaft Overhung Load		Output Speed (RPM)	Output Torque		Service Factor	Base				
	in-lbs	(N·m)		lbs	(N)		in-lbs	(N·m)		Motor Power Code	Frame Size	Ratio		
0.876	127000 (14300)		0.81	-	4740 (21100)	1.06	105000 (11900)		0.98	-	16300 (72500)	2	<b>4E18DA</b>	1656
			1.19	I	26700 (119000)				1.43	II	27600 (123000)	2	<b>4F18DA</b>	1656
			1.22	I	26700 (119000)				1.47	II	27600 (123000)	2	<b>4F19DA</b>	1656
0.741	150000 (16900)		1.01	I	25700 (114000)	0.894	124000 (14000)		1.21	I	26800 (119000)	2	<b>4F18DA</b>	1957
			1.03	I	25700 (114000)				1.24	I	26800 (119000)	2	<b>4F19DA</b>	1957
0.638	174000 (19600)		0.87	-	24500 (109000)	0.770	144000 (16300)		1.05	I	25900 (115000)	2	<b>4F18DA</b>	2272
			0.89	-	24500 (109000)				1.07	I	25900 (115000)	2	<b>4F19DA</b>	2272

# Standard Mounting Selection Tables

**3 HP  
(2.2 kW)**

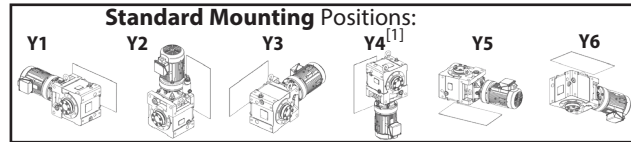

Dimension Pages:  
 Single Reduction 2.132-2.143  
 Single Reduction, Y2 2.144  
 Double Reduction 2.146-2.161  
 Double Reduction, Y2 2.162

Frequency	50 Hz	60 Hz
Input Speed	1450 RPM	1750 RPM
Number of Poles	4	

50Hz				60 Hz				Selection			VFD <sup>[2]</sup>			
Output Speed (RPM)	Output Torque		Service Factor	Solid Shaft Overhung Load		Output Speed (RPM)	Output Torque		Service Factor	Base				
	in-lbs	(N·m)		lbs	(N)		in-lbs	(N·m)		Motor Power Code	Frame Size	Ratio		
138	1240 (140)		1.07	I	3930 (17500)	167	1030 (116)		1.07	I	3730 (16600)	3	<b>4A100</b>	11
			1.45	II	3930 (17500)				1.45	II	3730 (16600)	3	<b>4A105</b>	11
			4.36	III	3930 (17500)				4.36	III	3730 (16600)	3	<b>4A120</b>	11
113	1510 (171)		1.07	I	4140 (18400)	137	1250 (142)		1.07	I	3940 (17500)	3	<b>4A100</b>	13
			1.45	II	4140 (18400)				1.45	II	3940 (17500)	3	<b>4A105</b>	13
			4.36	III	4140 (18400)				4.36	III	3940 (17500)	3	<b>4A120</b>	13
104	1660 (187)		1.07	I	4240 (18900)	125	1370 (155)		1.07	I	4030 (17900)	3	<b>4A100</b>	14
			1.45	II	4240 (18900)				1.45	II	4030 (17900)	3	<b>4A105</b>	14
			4.36	III	4240 (18900)				4.36	III	4030 (17900)	3	<b>4A120</b>	14
90.6	1890 (214)		1.07	I	4390 (19500)	109	1570 (177)		1.07	I	4180 (18600)	3	<b>4A100</b>	16
			1.45	II	4390 (19500)				1.45	II	4180 (18600)	3	<b>4A105</b>	16
			4.36	III	4360 (19400)				4.36	III	4150 (18500)	3	<b>4A120</b>	16
82.9	2070 (234)		1.07	I	4490 (20000)	100.0	1710 (194)		1.07	I	4280 (19000)	3	<b>4A100</b>	18
			1.45	II	4490 (20000)				1.45	II	4280 (19000)	3	<b>4A105</b>	18
			4.36	III	4470 (19900)				4.36	III	4250 (18900)	3	<b>4A120</b>	18
69.0	2480 (281)		1.07	I	4700 (20900)	83.3	2060 (232)		1.07	I	4480 (19900)	3	<b>4A100</b>	21
			1.45	II	4700 (20900)				1.45	II	4480 (19900)	3	<b>4A105</b>	21
			1.61	II	4700 (20900)				1.61	II	4480 (19900)	3	<b>4A110</b>	21
			1.78	II	4700 (20900)				1.78	II	4480 (19900)	3	<b>4A115</b>	21
			2.97	III	4700 (20900)				2.97	III	4480 (19900)	3	<b>4A120</b>	21
64.7	2650 (299)		2.97	III	4780 (21200)	78.1	2190 (248)		2.97	III	4560 (20300)	3	<b>4A120</b>	22
59.2	2900 (327)		2.97	III	4880 (21700)	71.4	2400 (271)		2.97	III	4660 (20700)	3	<b>4A120</b>	25
51.8	3310 (374)		1.07	I	5040 (22400)	62.5	2740 (310)		1.07	I	4820 (21400)	3	<b>4A100</b>	28
			1.45	II	5040 (22400)				1.45	II	4820 (21400)	3	<b>4A105</b>	28
			1.61	II	5040 (22400)				1.61	II	4820 (21400)	3	<b>4A110</b>	28
			1.78	II	5040 (22400)				1.78	II	4820 (21400)	3	<b>4A115</b>	28
			2.97	III	5040 (22400)				2.97	III	4820 (21400)	3	<b>4A120</b>	28
41.2	4160 (470)		1.07	I	5320 (23600)	49.7	3450 (390)		1.07	I	5090 (22600)	3	<b>4A100</b>	35
			1.45	II	5320 (23600)				1.45	II	5090 (22600)	3	<b>4A105</b>	35
			1.61	II	5320 (23600)				1.61	II	5090 (22600)	3	<b>4A110</b>	35
			1.78	II	5320 (23600)				1.78	II	5090 (22600)	3	<b>4A115</b>	35
			2.30	III	5320 (23600)				2.30	III	5090 (22600)	3	<b>4A120</b>	35
			2.69	III	5320 (23600)				2.69	III	5090 (22600)	3	<b>4A125</b>	35
			2.74	III	5320 (23600)				2.74	III	5090 (22600)	3	<b>4A140</b>	35

Notes: [1] For Y4 Double Reductions (4XXXDX) refer to the above table; for Y4 single reduction refer to tables on pages 2.91-2.130.  
 [2] Variable Frequency Drive (VFD) notes (see page 2.8 for Constant Torque Speed Ranges):  
 All 1HP+ motors require EP suffix in model number and can be used with a VFD, unless noted.

Notes: [1] For Y4 Double Reductions (4XXXDX) refer to the above table; for Y4 single reduction refer to tables on pages 2.91-2.130..  
 [2] Variable Frequency Drive (VFD) notes (see page 2.8 for Constant Torque Speed Ranges):  
 All 1HP+ motors require EP suffix in model number and can be used with a VFD, unless noted.

Cyclo® BBB4  
Selection Tables

Cyclo® BBB4  
Selection Tables

# Standard Mounting Selection Tables

**3 HP  
(2.2 kW)**

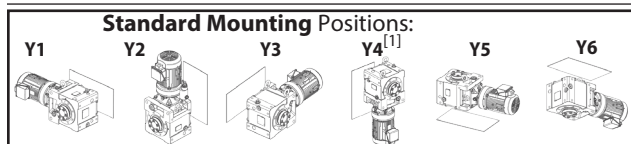

Dimension Pages:  
Single Reduction 2.132-2.143  
Single Reduction, Y2 2.144  
Double Reduction 2.146-2.161  
Double Reduction, Y2 2.162

Frequency	50 Hz	60 Hz
Input Speed	1450 RPM	1750 RPM
Number of Poles	4	

50Hz					60 Hz					Selection			VFD <sup>[2]</sup>			
Output Speed (RPM)	Output Torque		Service Factor		Solid Shaft Overhung Load		Output Speed (RPM)	Output Torque		Service Factor		Base				
	in-lbs	(N·m)	SF	AGMA Class	lbs	(N)		in-lbs	(N·m)	SF	AGMA Class	lbs	(N)	Motor Power Code	Frame Size	Ratio
37.7	4550	(514)	1.07	I	5420	(24100)	45.5	3770	(426)	1.07	I	5200	(23100)	3	<b>4A100</b>	39
			1.45	II	5420	(24100)				1.45	II	5200	(23100)	3	<b>4A105</b>	39
			1.61	II	5420	(24100)				1.61	II	5200	(23100)	3	<b>4A110</b>	39
			1.78	II	5420	(24100)				1.78	II	5200	(23100)	3	<b>4A115</b>	39
			2.30	III	5420	(24100)				2.30	III	5200	(23100)	3	<b>4A120</b>	39
			2.51	III	5420	(24100)				2.51	III	5200	(23100)	3	<b>4A125</b>	39
			2.69	III	7660	(34100)				2.69	III	7300	(32500)	3	<b>4B125</b>	39
31.9	5380	(608)	1.07	I	5620	(25000)	38.5	4460	(504)	1.07	I	5400	(24000)	3	<b>4A100</b>	46
			1.45	II	5620	(25000)				1.45	II	5400	(24000)	3	<b>4A105</b>	46
			1.61	II	5620	(25000)				1.61	II	5400	(24000)	3	<b>4A110</b>	46
			1.77	II	5620	(25000)				1.77	II	5400	(24000)	3	<b>4A115</b>	46
			2.12	III	5620	(25000)				2.12	III	5400	(24000)	3	<b>4A120</b>	46
			2.30	III	7990	(35600)				2.30	III	7620	(33900)	3	<b>4B120</b>	46
			2.69	III	7990	(35600)				2.69	III	7620	(33900)	3	<b>4B125</b>	46
27.6	6210	(701)	1.07	I	5440	(24200)	33.3	5140	(581)	1.07	I	5570	(24800)	3	<b>4A100</b>	53
			1.45	II	5440	(24200)				1.45	II	5570	(24800)	3	<b>4A105</b>	53
			1.61	II	5440	(24200)				1.61	II	5570	(24800)	3	<b>4A110</b>	53
			1.77	II	5440	(24200)				1.77	II	5570	(24800)	3	<b>4A115</b>	53
			1.84	II	5440	(24200)				1.84	II	5570	(24800)	3	<b>4A120</b>	53
			2.30	III	8280	(36800)				2.30	III	7900	(35200)	3	<b>4B120</b>	53
			2.69	III	8280	(36800)				2.69	III	7900	(35200)	3	<b>4B125</b>	53
24.4	7040	(795)	1.12	I	5210	(23200)	29.4	5830	(659)	1.12	I	5530	(24600)	3	<b>4A105</b>	60
			1.45	II	5210	(23200)				1.45	II	5530	(24600)	3	<b>4A110</b>	60
			1.62	II	5210	(23200)				1.62	II	5530	(24600)	3	<b>4A115</b>	60
			2.22	III	8530	(38000)				2.30	III	8150	(36300)	3	<b>4B120</b>	60
			2.57	III	8530	(38000)				2.57	III	8150	(36300)	3	<b>4B125</b>	60
21.6	7950	(898)	1.04	I	4920	(21900)	26.0	6580	(744)	1.06	I	5340	(23800)	3	<b>4A105</b>	67
			1.24	I	4920	(21900)				1.24	I	5340	(23800)	3	<b>4A110</b>	67
			1.44	II	4920	(21900)				1.44	II	5340	(23800)	3	<b>4A120</b>	67
			1.80	II	8780	(39100)				1.80	II	8400	(37400)	3	<b>4B120</b>	67
			2.18	III	8780	(39100)				2.22	III	8400	(37400)	3	<b>4B125</b>	67
			2.86	III	8780	(39100)				2.86	III	8400	(37400)	3	<b>4B140</b>	67
			19.7	8690	(982)	1.04				I	4650	(20700)	23.8	7200	(814)	1.06
1.31	I	4650				(20700)	1.31	I	5170	(23000)	3	<b>4A115</b>				74
2.18	III	8960				(39900)	2.22	III	8580	(38200)	3	<b>4B125</b>				74
2.62	III	8960				(39900)	2.62	III	8580	(38200)	3	<b>4B140</b>				74

Notes: [1] For Y4 Double Reductions (4XXXDX) refer to the above table; for Y4 single reduction refer to tables on pages 2.91-2.130.

[2] Variable Frequency Drive (VFD) notes (see page 2.8 for Constant Torque Speed Ranges):

All 1HP+ motors require EP suffix in model number and can be used with a VFD, unless noted.

# Standard Mounting Selection Tables

**3 HP  
(2.2 kW)**

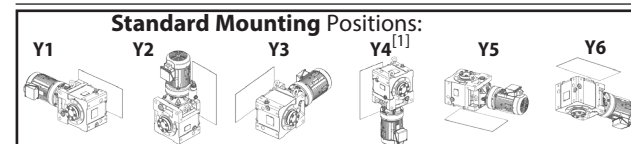

Dimension Pages:  
Single Reduction 2.132-2.143  
Single Reduction, Y2 2.144  
Double Reduction 2.146-2.161  
Double Reduction, Y2 2.162

Frequency	50 Hz	60 Hz
Input Speed	1450 RPM	1750 RPM
Number of Poles	4	

50Hz					60 Hz					Selection			VFD <sup>[2]</sup>			
Output Speed (RPM)	Output Torque		Service Factor		Solid Shaft Overhung Load		Output Speed (RPM)	Output Torque		Service Factor		Base				
	in-lbs	(N·m)	SF	AGMA Class	lbs	(N)		in-lbs	(N·m)	SF	AGMA Class	lbs	(N)	Motor Power Code	Frame Size	Ratio
18.1	9460	(1070)	0.87	-	4310	(19200)	21.9	7840	(886)	0.87	-	4960	(22100)	3	<b>4A110</b>	80
			1.01	I	4310	(19200)				1.01	I	4960	(22100)	3	<b>4A115</b>	80
			1.21	I	4310	(19200)				1.21	I	4960	(22100)	3	<b>4A120</b>	80
			1.40	II	9140	(40600)				1.40	II	8750	(38900)	3	<b>4B120</b>	80
			1.80	II	9140	(40600)				1.80	II	8750	(38900)	3	<b>4B125</b>	80
			2.40	III	9140	(40600)				2.40	III	8750	(38900)	3	<b>4B140</b>	80
			16.6	10300	(1170)	0.87				-	3850	(17100)	20.0	8570	(969)	0.87
1.01	I	3850				(17100)	1.01	I	4690	(20900)	3	<b>4A115</b>				88
1.10	I	3850				(17100)	1.10	I	4690	(20900)	3	<b>4A120</b>				88
1.40	II	9320				(41400)	1.40	II	8940	(39800)	3	<b>4B120</b>				88
1.80	II	9320				(41400)	1.80	II	8940	(39800)	3	<b>4B125</b>				88
2.20	III	9320				(41400)	2.20	III	8940	(39800)	3	<b>4B140</b>				88
14.3	12000	(1360)				0.95	-	2610	(11600)	17.2	9940	(1120)				0.95
			1.30	I	9050	(40300)	1.36	I	9240				(41100)	3	<b>4B120</b>	102
			1.58	II	9050	(40300)	1.71	II	9240				(41100)	3	<b>4B125</b>	102
			1.90	II	9050	(40300)	1.90	II	9240				(41100)	3	<b>4B140</b>	102
			2.70	III	13900	(61600)	2.70	III	13200				(58800)	3	<b>4C140</b>	102
12.9	13200	(1500)	1.08	I	8820	(39200)	15.6	11000	(1240)	1.13	I	9220	(41000)	3	<b>4B120</b>	112
			1.31	I	8820	(39200)				1.45	II	9220	(41000)	3	<b>4B125</b>	112
			1.72	II	8820	(39200)				1.72	II	9220	(41000)	3	<b>4B140</b>	112
			2.84	III	14200	(63100)				3.42	III	13600	(60300)	3	<b>4C145</b>	112
			11.8	14500	(1640)	1.08				I	8560	(38100)	14.3	12000	(1360)	1.13
1.31	I	8560				(38100)	1.45	II	9050	(40300)	3	<b>4B125</b>				123
1.57	II	8560				(38100)	1.57	II	9050	(40300)	3	<b>4B140</b>				123
2.37	III	14500				(64500)	2.37	III	13900	(61600)	3	<b>4C140</b>				123
2.84	III	14500				(64500)	3.14	III	13900	(61600)	3	<b>4C145</b>				123
9.63	17800	(2010)	1.06	I	7690	(34200)	11.6	14700	(1670)	1.08	I	8500	(37800)	3	<b>4B125</b>	151
			1.28	I	7690	(34200)				1.28	I	8500	(37800)	3	<b>4B140</b>	151
			1.79	II	15200	(67600)				1.79	II	14600	(64700)	3	<b>4C140</b>	151
			2.12	III	15200	(67600)				2.45	III	14600	(64700)	3	<b>4C145</b>	151
			2.49	III	15200	(67600)				2.56	III	14600	(64700)	3	<b>4C160</b>	151
			2.93	III	21700	(96400)				3.39	III	21800	(97000)	3	<b>4D160</b>	151
			8.12	21100	(2380)	0.90				-	6500	(28900)	9.80	17500	(1980)	1.04
1.08	I	6500				(28900)	1.08	I	7790	(34600)	3	<b>4B140</b>				179
1.56	II	15000				(66500)	1.56	II	15100	(67300)	3	<b>4C140</b>				179
1.68	II	15000				(66500)	1.92	II	15100	(67300)	3	<b>4C145</b>				179
2.10	III	15000				(66500)	2.16	III	15100	(67300)	3	<b>4C160</b>				179
2.99	III	21500				(95600)	3.42	III	21700	(96500)	3	<b>4D165</b>				179

Notes: [1] For Y4 Double Reductions (4XXXDX) refer to the above table; for Y4 single reduction refer to tables on pages 2.91-2.130.

[2] Variable Frequency Drive (VFD) notes (see page 2.8 for Constant Torque Speed Ranges):

All 1HP+ motors require EP suffix in model number and can be used with a VFD, unless noted.

# Standard Mounting Selection Tables

**3 HP  
(2.2 kW)**

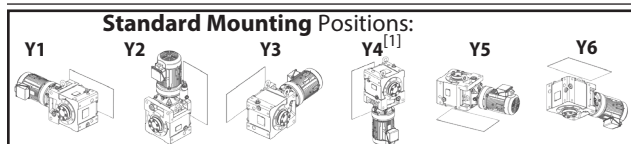

Dimension Pages:  
Single Reduction, Y2 2.132-2.143  
Single Reduction, Y2 2.144  
Double Reduction 2.146-2.161  
Double Reduction, Y2 2.162

Frequency	50 Hz	60 Hz
Input Speed	1450 RPM	1750 RPM
Number of Poles	4	

50Hz					60 Hz					Selection							
Output Speed (RPM)	Output Torque		Service Factor		Solid Shaft Overhung Load		Output Speed (RPM)	Output Torque		Service Factor		Solid Shaft Overhung Load		Base			VFD <sup>[2]</sup>
	in-lbs	(N·m)	SF	AGMA Class	lbs	(N)		in-lbs	(N·m)	SF	AGMA Class	lbs	(N)	Motor Power Code	Frame Size	Ratio	
7.02	24400 (2760)		0.93	-	4730 (21000)	8.47	20200 (2290)	0.93	-	6850 (30500)	3	<b>4B140</b>	207				
			1.35	I	14500 (64600)			1.35	I	15100 (67000)	3	<b>4C140</b>	207				
			1.45	II	14500 (64600)			1.66	II	15100 (67000)	3	<b>4C145</b>	207				
			1.82	II	14500 (64600)			1.86	II	15100 (67000)	3	<b>4C160</b>	207				
			2.01	III	21300 (94700)			2.01	III	21500 (95900)	3	<b>4D160</b>	207				
			2.59	III	21300 (94700)			2.61	III	21500 (95900)	3	<b>4D165</b>	207				
5.84	29400 (3320)		1.10	I	13700 (61100)	7.04	24300 (2750)	1.10	I	14500 (64700)	3	<b>4C140</b>	249				
			1.19	I	13700 (61100)			1.38	I	14500 (64700)	3	<b>4C145</b>	249				
			1.51	II	13700 (61100)			1.55	II	14500 (64700)	3	<b>4C160</b>	249				
			2.15	III	20900 (93000)			2.57	III	21300 (94700)	3	<b>4D165</b>	249				
4.76	36000 (4070)		0.90	-	12400 (55000)	5.75	29800 (3370)	0.90	-	13700 (60800)	3	<b>4C140</b>	305				
			0.98	-	12400 (55000)			1.13	I	13700 (60800)	3	<b>4C145</b>	305				
			1.23	I	12400 (55000)			1.26	I	13700 (60800)	3	<b>4C160</b>	305				
			1.47	II	20300 (90200)			1.58	II	20900 (92800)	3	<b>4D160</b>	305				
			1.71	II	20300 (90200)			1.77	II	20900 (92800)	3	<b>4D165</b>	305				
			3.98	40800 (4610)	1.01			I	10300 (46000)	4.81	33800 (3820)	1.22	I			12500 (55400)	3
1.11	I	10300 (46000)	1.34	I	12500 (55400)	3	<b>4C16DB</b>	364									
1.89	II	19400 (86400)	2.28	III	20300 (90300)	3	<b>4D17DC</b>	364									
2.32	III	21700 (96700)	2.80	III	22100 (98300)	3	<b>4E17DC</b>	364									
2.51	III	21700 (96700)	3.03	III	22100 (98300)	3	<b>4E18DB</b>	364									
3.42	47500 (5370)		0.82	-	7250 (32200)	4.13	39400 (4450)	0.99	-	10900 (48300)	3	<b>4C14DC</b>	424				
			0.96	-	7250 (32200)			1.16	I	10900 (48300)	3	<b>4C16DB</b>	424				
			1.33	I	18400 (81700)			1.45	II	19600 (87300)	3	<b>4D16DB</b>	424				
			1.62	II	18400 (81700)			1.96	II	19600 (87300)	3	<b>4D17DC</b>	424				
			2.00	III	21400 (95200)			2.41	III	21800 (97000)	3	<b>4E17DC</b>	424				
			2.16	III	21400 (95200)			2.61	III	21800 (97000)	3	<b>4E18DB</b>	424				
2.90	56200 (6350)		1.13	I	16700 (74100)	3.50	46500 (5260)	1.36	I	18500 (82500)	3	<b>4D16DB</b>	501				
			1.37	I	16700 (74100)			1.45	II	18500 (82500)	3	<b>4D17DB</b>	501				
			1.45	II	21000 (93200)			1.45	II	21400 (95400)	3	<b>4E17DB</b>	501				
			1.69	II	21000 (93200)			2.04	III	21400 (95400)	3	<b>4E17DC</b>	501				
			1.83	II	21000 (93200)			2.21	III	21400 (95400)	3	<b>4E18DB</b>	501				
			2.63	III	29700 (132000)			3.17	III	30200 (134000)	3	<b>4F18DB</b>	501				
			2.74	III	29700 (132000)			3.31	III	30200 (134000)	3	<b>4F19DB</b>	501				

Notes: [1] For Y4 Double Reductions (4XXXDX) refer to the above table; for Y4 single reduction refer to tables on pages 2.91-2.130.

[2] Variable Frequency Drive (VFD) notes (see page 2.8 for Constant Torque Speed Ranges):

All 1HP+ motors require EP suffix in model number and can be used with a VFD, unless noted.

# Standard Mounting Selection Tables

**3 HP  
(2.2 kW)**

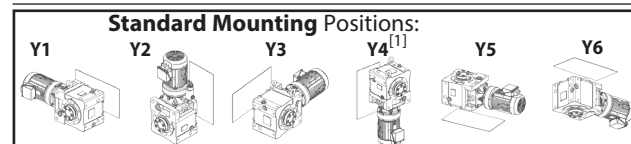

Dimension Pages:  
Single Reduction 2.132-2.143  
Single Reduction, Y2 2.144  
Double Reduction 2.146-2.161  
Double Reduction, Y2 2.162

Frequency	50 Hz	60 Hz
Input Speed	1450 RPM	1750 RPM
Number of Poles	4	

50Hz					60 Hz					Selection							
Output Speed (RPM)	Output Torque		Service Factor		Solid Shaft Overhung Load		Output Speed (RPM)	Output Torque		Service Factor		Solid Shaft Overhung Load		Base			VFD <sup>[2]</sup>
	in-lbs	(N·m)	SF	AGMA Class	lbs	(N)		in-lbs	(N·m)	SF	AGMA Class	lbs	(N)	Motor Power Code	Frame Size	Ratio	
2.51	64800 (7320)		0.98	-	14400 (64100)	3.03	53700 (6070)	1.18	I	17200 (76500)	3	<b>4D16DB</b>	578				
			1.19	I	14400 (64100)			1.44	II	17200 (76500)	3	<b>4D17DB</b>	578				
			1.45	II	20500 (91300)			1.45	II	21100 (93800)	3	<b>4E17DB</b>	578				
			1.58	II	20500 (91300)			1.91	II	21100 (93800)	3	<b>4E18DB</b>	578				
			2.29	III	29400 (131000)			2.76	III	29800 (133000)	3	<b>4F18DB</b>	578				
			2.38	III	29400 (131000)			2.87	III	29800 (133000)	3	<b>4F19DB</b>	578				
2.12	76600 (8650)		0.83	-	9800 (43600)	2.56	63500 (7170)	1.00	I	14800 (65900)	3	<b>4D16DB</b>	683				
			1.01	I	9800 (43600)			1.22	I	14800 (65900)	3	<b>4D17DB</b>	683				
			1.24	I	19900 (88600)			1.45	II	20600 (91600)	3	<b>4E17DB</b>	683				
			1.34	I	19900 (88600)			1.62	II	20600 (91600)	3	<b>4E18DB</b>	683				
			1.94	II	28900 (128000)			2.34	III	29400 (131000)	3	<b>4F18DB</b>	683				
			2.01	III	28900 (128000)			2.43	III	29400 (131000)	3	<b>4F19DB</b>	683				
1.79	90700 (10300)		1.05	I	19200 (85400)	2.16	75200 (8490)	1.26	I	20000 (88900)	3	<b>4E17DB</b>	809				
			1.13	I	19200 (85400)			1.37	I	20000 (88900)	3	<b>4E18DA</b>	809				
			1.45	II	28200 (126000)			1.45	II	28900 (129000)	3	<b>4F18DA</b>	809				
			1.66	II	28200 (126000)			2.00	III	28900 (129000)	3	<b>4F18DB</b>	809				
			1.70	II	28200 (126000)			2.05	III	28900 (129000)	3	<b>4F19DA</b>	809				
			1.52	107000 (12100)	0.88			-	15600 (69300)	1.83	88800 (10000)	1.07	I			19300 (85900)	3
0.96	-	15600 (69300)	1.16	I	19300 (85900)	3	<b>4E18DA</b>	956									
1.40	II	27500 (122000)	1.45	II	28300 (126000)	3	<b>4F18DA</b>	956									
1.40	II	27500 (122000)	1.70	II	28300 (126000)	3	<b>4F18DB</b>	956									
1.44	II	27500 (122000)	1.73	II	28300 (126000)	3	<b>4F19DA</b>	956									
1.30	125000 (14200)		0.82	-	6260 (27800)	1.57	104000 (11700)	0.99	-	16700 (74100)	3	<b>4E18DA</b>	1117				
			1.20	I	26800 (119000)			1.45	II	27700 (123000)	3	<b>4F18DA</b>	1117				
			1.20	I	26800 (119000)			1.45	II	27700 (123000)	3	<b>4F18DB</b>	1117				
			1.23	I	26800 (119000)			1.48	II	27700 (123000)	3	<b>4F19DA</b>	1117				
			1.10	148000 (16700)	1.02			I	25800 (115000)	1.33	123000 (13900)	1.23	I			26900 (120000)	3
1.04	I	25800 (115000)	1.26	I	26900 (120000)	3	<b>4F19DA</b>	1320									
0.876	186000 (21000)		0.81	-	20300 (90200)	1.06	154000 (17400)	0.98	-	25500 (113000)	3	<b>4F18DA</b>	1656				
			0.83	-	20300 (90200)			1.00	I	25500 (113000)	3	<b>4F19DA</b>	1656				

Notes: [1] For Y4 Double Reductions (4XXXDX) refer to the above table; for Y4 single reduction refer to tables on pages 2.91-2.130.

[2] Variable Frequency Drive (VFD) notes (see page 2.8 for Constant Torque Speed Ranges):

All 1HP+ motors require EP suffix in model number and can be used with a VFD, unless noted.

# Standard Mounting Selection Tables

**5 HP  
(3.7 kW)**

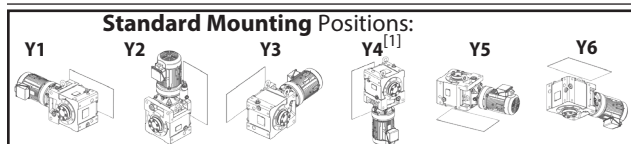

Dimension Pages:  
Single Reduction 2.132-2.143  
Single Reduction, Y2 2.144  
Double Reduction 2.146-2.161  
Double Reduction, Y2 2.162

Frequency	50 Hz	60 Hz
Input Speed	1450 RPM	1750 RPM
Number of Poles	4	

50Hz					60 Hz					Selection							
Output Speed (RPM)	Output Torque		Service Factor		Solid Shaft Overhung Load		Output Speed (RPM)	Output Torque		Service Factor		Solid Shaft Overhung Load		Base			VFD <sup>[2]</sup>
	in-lbs	(N·m)	SF	AGMA Class	lbs	(N)		in-lbs	(N·m)	SF	AGMA Class	lbs	(N)	Motor Power Code	Frame Size	Ratio	
138	2090 (236)		2.59	III	3810 (16900)	167	1730 (195)		2.59	III	3630 (16200)	5	4A120	11			
			2.98	III	3810 (16900)				2.98	III	3630 (16200)						
113	2550 (288)		2.59	III	4000 (17800)	137	2110 (238)		2.59	III	3820 (17000)	5	4A120	13			
			2.98	III	4000 (17800)				2.98	III	3820 (17000)						
104	2780 (315)		2.59	III	4080 (18200)	125	2310 (261)		2.59	III	3900 (17400)	5	4A120	14			
			2.98	III	4080 (18200)				2.98	III	3900 (17400)						
90.6	3180 (359)		2.59	III	4190 (18600)	109	2640 (298)		2.59	III	4010 (17800)	5	4A120	16			
			2.98	III	4190 (18600)				2.98	III	4010 (17800)						
82.9	3480 (393)		2.59	III	4280 (19000)	100.0	2880 (326)		2.59	III	4100 (18200)	5	4A120	18			
			2.98	III	4280 (19000)				2.98	III	4100 (18200)						
69.0	4180 (472)		1.06	I	4470 (19900)	83.3	3460 (391)		1.06	I	4290 (19100)	5	4A115	21			
			1.77	II	4470 (19900)				1.77	II	4290 (19100)						
			2.03	III	4470 (19900)				2.03	III	4290 (19100)						
			2.73	III	4470 (19900)				2.73	III	4290 (19100)						
64.7	4450 (503)		1.77	II	4530 (20100)	78.1	3690 (417)		1.77	II	4350 (19400)	5	4A120	22			
			2.03	III	4530 (20100)				2.03	III	4350 (19400)						
			2.56	III	4530 (20100)				2.56	III	4350 (19400)						
59.2	4870 (550)		1.77	II	4610 (20500)	71.4	4040 (456)		1.77	II	4440 (19700)	5	4A120	25			
			2.03	III	4610 (20500)				2.03	III	4440 (19700)						
			2.34	III	4610 (20500)				2.34	III	4440 (19700)						
			2.56	III	4610 (20500)				2.56	III	4440 (19700)						
51.8	5570 (629)		1.06	I	4730 (21100)	62.5	4610 (521)		1.06	I	4560 (20300)	5	4A115	28			
			1.77	II	4730 (21100)				1.77	II	4560 (20300)						
			2.03	III	4730 (21100)				2.03	III	4560 (20300)						
41.2	7000 (791)		1.06	I	4930 (21900)	49.7	5800 (655)		1.06	I	4770 (21200)	5	4A115	35			
			1.37	I	4930 (21900)				1.37	I	4770 (21200)						
			1.60	II	4930 (21900)				1.60	II	4770 (21200)						
			1.63	II	4930 (21900)				1.63	II	4770 (21200)						
			3.25	III	7180 (32000)				3.25	III	6880 (30600)						
37.7	7660 (865)		1.06	I	5000 (22200)	45.5	6340 (717)		1.06	I	4850 (21600)	5	4A115	39			
			1.37	I	5000 (22200)				1.37	I	4850 (21600)						
			1.49	II	5000 (22200)				1.49	II	4850 (21600)						
			1.60	II	7330 (32600)				1.60	II	7020 (31200)						
			2.97	III	7330 (32600)				2.97	III	7020 (31200)						
31.9	9050 (1020)		1.05	I	4500 (20000)	38.5	7500 (847)		1.05	I	4980 (22200)	5	4A115	46			
			1.26	I	4500 (20000)				1.26	I	4980 (22200)						
			1.37	I	7600 (33800)				1.37	I	7300 (32500)						
			1.60	II	7600 (33800)				1.60	II	7300 (32500)						
			2.51	III	7600 (33800)				2.51	III	7300 (32500)						
			2.51	III	7600 (33800)				2.51	III	7300 (32500)						

Notes: [1] For Y4 Double Reductions (4XXXDX) refer to the above table; for Y4 single reduction refer to tables on pages 2.91-2.130.

[2] Variable Frequency Drive (VFD) notes (see page 2.8 for Constant Torque Speed Ranges):

All 1HP+ motors require EP suffix in model number and can be used with a VFD, unless noted.

# Standard Mounting Selection Tables

**5 HP  
(3.7 kW)**

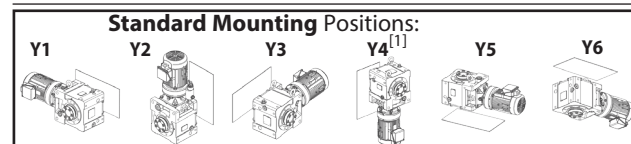

Dimension Pages:  
Single Reduction 2.132-2.143  
Single Reduction, Y2 2.144  
Double Reduction 2.146-2.161  
Double Reduction, Y2 2.162

Frequency	50 Hz	60 Hz
Input Speed	1450 RPM	1750 RPM
Number of Poles	4	

50Hz					60 Hz					Selection							
Output Speed (RPM)	Output Torque		Service Factor		Solid Shaft Overhung Load		Output Speed (RPM)	Output Torque		Service Factor		Solid Shaft Overhung Load		Base			VFD <sup>[2]</sup>
	in-lbs	(N·m)	SF	AGMA Class	lbs	(N)		in-lbs	(N·m)	SF	AGMA Class	lbs	(N)	Motor Power Code	Frame Size	Ratio	
27.6	10400 (1180)		1.05	I	3790 (16900)	33.3	8650 (977)		1.05	I	4660 (20700)	5	4A115	53			
			1.09	I	3790 (16900)				1.09	I	4660 (20700)						
			1.37	I	7820 (34800)				1.37	I	7530 (33500)						
			1.60	II	7820 (34800)				1.60	II	7530 (33500)						
			2.18	III	7820 (34800)				2.18	III	7530 (33500)						
24.4	11800 (1340)		0.96	-	2780 (12300)	29.4	9800 (1110)		0.96	-	4140 (18400)	5	4A115	60			
			1.32	I	8020 (35700)				1.32	I	7730 (34400)						
			1.53	II	8020 (35700)				1.53	II	7730 (34400)						
			1.92	II	8020 (35700)				1.92	II	7730 (34400)						
21.6	13400 (1510)		1.07	I	8200 (36500)	26.0	11100 (1250)		1.07	I	7910 (35200)	5	4B120	67			
			1.30	I	8200 (36500)				1.30	I	7910 (35200)						
			1.70	II	8200 (36500)				1.70	II	7910 (35200)						
			2.34	III	12000 (53300)				2.34	III	11500 (51000)						
			2.56	III	12000 (53300)				2.56	III	11500 (51000)						
19.7	14600 (1650)		1.07	I	8320 (37000)	23.8	12100 (1370)		1.07	I	8050 (35800)	5	4B120	74			
			1.30	I	8320 (37000)				1.30	I	8050 (35800)						
			1.56	II	8320 (37000)				1.56	II	8050 (35800)						
			2.34	III	12200 (54400)				2.34	III	11700 (52100)						
			2.56	III	12200 (54400)				2.56	III	11700 (52100)						
18.1	15900 (1800)		1.07	I	8220 (36600)	21.9	13200 (1490)		1.07	I	8180 (36400)	5	4B125	80			
			1.43	II	8220 (36600)				1.43	II	8180 (36400)						
			1.86	II	12500 (55400)				1.86	II	11900 (53100)						
			2.14	III	12500 (55400)				2.14	III	11900 (53100)						
			2.66	III	12500 (55400)				2.66	III	11900 (53100)						
			2.86	III	12500 (55400)				2.86	III	11900 (53100)						
16.6	17400 (1970)		1.07	I	7810 (34700)	20.0	14400 (1630)		1.07	I	8310 (36900)	5	4B125	88			
			1.31	I	7810 (34700)				1.31	I	8310 (36900)						
			1.86	II	12700 (56500)				1.86	II	12200 (54200)						
			2.14	III	12700 (56500)				2.14	III	12200 (54200)						
			2.55	III	12700 (56500)				2.55	III	12200 (54200)						
			2.66	III	19300 (85800)				2.66	III	18400 (81900)						
14.3	20200 (2280)		0.94	-	6870 (30600)	17.2	16700 (1890)		1.02	I	8000 (35600)	5	4B125	102			
			1.13	I	6870 (30600)				1.13	I	8000 (35600)						
			1.61	II	13100 (58200)				1.61	II	12600 (56000)						
			2.04	III	13100 (58200)				2.04	III	12600 (56000)						
			2.20	III	13100 (58200)				2.20	III	12600 (56000)						
			2.25	III	13100 (58200)				2.25	III	12600 (56000)						
			2.58	III	20000 (89000)				2.58	III	19100 (85000)						

Notes: [1] For Y4 Double Reductions (4XXXDX) refer to the above table; for Y4 single reduction refer to tables on pages 2.91-2.130.

[2] Variable Frequency Drive (VFD) notes (see page 2.8 for Constant Torque Speed Ranges):

All 1HP+ motors require EP suffix in model number and can be used with a VFD, unless noted.



# Standard Mounting Selection Tables

**5 HP  
(3.7 kW)**

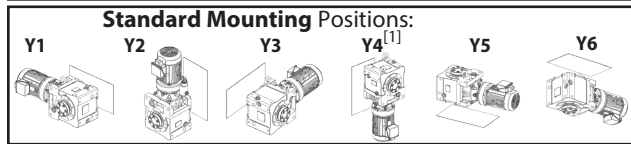

Dimension Pages:  
Single Reduction, Y2 2.132-2.143  
Single Reduction, Y2 2.144  
Double Reduction 2.146-2.161  
Double Reduction, Y2 2.162

Frequency	50 Hz	60 Hz
Input Speed	1450 RPM	1750 RPM
Number of Poles	4	

50Hz					60 Hz					Selection							
Output Speed (RPM)	Output Torque		Service Factor		Solid Shaft Overhung Load		Output Speed (RPM)	Output Torque		Service Factor		Solid Shaft Overhung Load		Base			VFD <sup>[2]</sup>
	in-lbs	(N·m)	SF	AGMA Class	lbs	(N)		in-lbs	(N·m)	SF	AGMA Class	lbs	(N)	Motor Power Code	Frame Size	Ratio	
12.9	22300 (2520)		1.02	I	5960 (26500)	15.6	18500 (2090)	1.02	I	7490 (33300)	5	<b>4B140</b>	112				
			1.41	II	13300 (59300)			1.41	II	12800 (57100)	5	<b>4C140</b>	112				
			1.69	II	13300 (59300)			2.04	III	12800 (57100)	5	<b>4C145</b>	112				
			2.04	III	13300 (59300)			2.04	III	12800 (57100)	5	<b>4C160</b>	112				
			2.17	III	20500 (91200)			2.61	III	19600 (87100)	5	<b>4D160</b>	112				
			2.59	III	20500 (91200)			3.08	III	19600 (87100)	5	<b>4D165</b>	112				
11.8	24400 (2750)		0.93	-	4760 (21200)	14.3	20200 (2280)	0.93	-	6870 (30600)	5	<b>4B140</b>	123				
			1.41	II	13600 (60300)			1.41	II	13100 (58200)	5	<b>4C140</b>	123				
			1.69	II	13600 (60300)			1.87	II	13100 (58200)	5	<b>4C145</b>	123				
			1.82	II	13600 (60300)			1.87	II	13100 (58200)	5	<b>4C160</b>	123				
			2.17	III	20900 (93100)			2.61	III	20000 (89000)	5	<b>4D160</b>	123				
			2.59	III	20900 (93100)			3.08	III	20000 (89000)	5	<b>4D165</b>	123				
9.63	29900 (3380)		1.06	I	13600 (60700)	11.6	24800 (2800)	1.06	I	13600 (60500)	5	<b>4C140</b>	151				
			1.26	I	13600 (60700)			1.46	II	13600 (60500)	5	<b>4C145</b>	151				
			1.48	II	13600 (60700)			1.52	II	13600 (60500)	5	<b>4C160</b>	151				
			1.74	II	20900 (92800)			2.01	III	21000 (93500)	5	<b>4D160</b>	151				
			2.11	III	20900 (92800)			2.14	III	21000 (93500)	5	<b>4D165</b>	151				
			2.45	III	20900 (92800)			2.58	III	21000 (93500)	5	<b>4D170</b>	151				
			2.58	III	20900 (92800)			2.58	III	21000 (93500)	5	<b>4D175</b>	151				
			2.58	III	20900 (92800)			3.11	III	21000 (93500)	5	<b>4D180</b>	151	(-)			
8.12	35500 (4010)		1.00	I	12500 (55600)	9.80	29400 (3320)	1.14	I	13700 (61100)	5	<b>4C145</b>	179				
			1.25	I	12500 (55600)			1.28	I	13700 (61100)	5	<b>4C160</b>	179				
			1.49	II	20300 (90400)			1.55	II	20900 (93000)	5	<b>4D160</b>	179				
			1.78	II	20300 (90400)			2.04	III	20900 (93000)	5	<b>4D165</b>	179				
			2.07	III	20300 (90400)			2.17	III	20900 (93000)	5	<b>4D170</b>	179				
			2.17	III	20300 (90400)			2.17	III	20900 (93000)	5	<b>4D175</b>	179				
			2.17	III	20300 (90400)			2.62	III	20900 (93000)	5	<b>4D180</b>	179	(-)			
			2.67	III	22000 (97900)			2.89	III	22300 (99300)	5	<b>4E175</b>	179				
			2.89	III	22000 (97900)			3.24	III	22300 (99300)	5	<b>4E180</b>	179	(-)			
			2.89	III	22000 (97900)			3.49	III	22300 (99300)	5	<b>4E185</b>	179	(-)			

Notes: [1] For Y4 Double Reductions (4XXXDX) refer to the above table; for Y4 single reduction refer to tables on pages 2.91-2.130.

[2] Variable Frequency Drive (VFD) notes (see page 2.8 for Constant Torque Speed Ranges):

All 1HP+ motors require EP suffix in model number and can be used with a VFD, unless noted.

(-) = For Inverter Operation, starting condition may require ambient temperature of 5° C or higher.

# Standard Mounting Selection Tables

**5 HP  
(3.7 kW)**

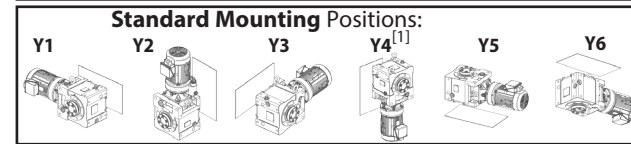

Dimension Pages:  
Single Reduction 2.132-2.143  
Single Reduction, Y2 2.144  
Double Reduction 2.146-2.161  
Double Reduction, Y2 2.162

Frequency	50 Hz	60 Hz
Input Speed	1450 RPM	1750 RPM
Number of Poles	4	

50Hz					60 Hz					Selection							
Output Speed (RPM)	Output Torque		Service Factor		Solid Shaft Overhung Load		Output Speed (RPM)	Output Torque		Service Factor		Solid Shaft Overhung Load		Base			VFD <sup>[2]</sup>
	in-lbs	(N·m)	SF	AGMA Class	lbs	(N)		in-lbs	(N·m)	SF	AGMA Class	lbs	(N)	Motor Power Code	Frame Size	Ratio	
7.02	41100 (4640)		0.86	-	11000 (48900)	8.47	34000 (3840)	0.99	-	12800 (57100)	5	<b>4C145</b>	207				
			1.08	I	11000 (48900)			1.11	I	12800 (57100)	5	<b>4C160</b>	207				
			1.19	I	19700 (87500)			1.19	I	20500 (91100)	5	<b>4D160</b>	207				
			1.54	II	19700 (87500)			1.55	II	20500 (91100)	5	<b>4D165</b>	207				
			1.79	II	19700 (87500)			1.88	II	20500 (91100)	5	<b>4D170</b>	207				
			1.88	II	19700 (87500)			1.88	II	20500 (91100)	5	<b>4D175</b>	207				
			1.88	II	19700 (87500)			2.27	III	20500 (91100)	5	<b>4D180</b>	207	(-)			
			2.24	III	21700 (96600)			2.24	III	22100 (98200)	5	<b>4E175</b>	207				
			2.50	III	21700 (96600)			2.64	III	22100 (98200)	5	<b>4E180</b>	207	(-)			
			2.50	III	21700 (96600)			3.02	III	22100 (98200)	5	<b>4E185</b>	207	(-)			
5.84	49400 (5580)		0.90	-	7610 (33900)	7.04	40900 (4630)	0.92	-	11000 (49000)	5	<b>4C160</b>	249				
			1.28	I	18500 (82200)			1.53	II	19700 (87600)	5	<b>4D165</b>	249				
			1.49	II	18500 (82200)			1.56	II	19700 (87600)	5	<b>4D170</b>	249				
			1.56	II	18500 (82200)			1.56	II	19700 (87600)	5	<b>4D175</b>	249				
			1.56	II	18500 (82200)			1.88	II	19700 (87600)	5	<b>4D180</b>	249	(-)			
			1.89	II	21300 (94800)			1.93	II	21700 (96700)	5	<b>4E175</b>	249				
			2.08	III	21300 (94800)			2.38	III	21700 (96700)	5	<b>4E180</b>	249	(-)			
			2.08	III	21300 (94800)			2.51	III	21700 (96700)	5	<b>4E185</b>	249	(-)			
			2.38	III	30000 (134000)			2.38	III	30400 (135000)	5	<b>4F180</b>	249	(-)			
			2.65	III	30000 (134000)			2.65	III	30400 (135000)	5	<b>4F185</b>	249	(-)			
4.76	60600 (6840)		0.87	-	16400 (72800)	5.75	50200 (5670)	0.94	-	18400 (81700)	5	<b>4D160</b>	305				
			1.02	I	16400 (72800)			1.05	I	18400 (81700)	5	<b>4D165</b>	305				
			1.27	I	16400 (72800)			1.27	I	18400 (81700)	5	<b>4D175</b>	305				
			1.27	I	16400 (72800)			1.54	II	18400 (81700)	5	<b>4D180</b>	305	(-)			
			1.52	II	20700 (92200)			1.52	II	21300 (94600)	5	<b>4E175</b>	305				
			1.70	II	20700 (92200)			1.93	II	21300 (94600)	5	<b>4E180</b>	305	(-)			
			1.70	II	20700 (92200)			2.05	III	21300 (94600)	5	<b>4E185</b>	305	(-)			
			1.93	II	29600 (131000)			1.93	II	30000 (133000)	5	<b>4F180</b>	305	(-)			
			2.32	III	29600 (131000)			2.32	III	30000 (133000)	5	<b>4F185</b>	305	(-)			
			2.63	III	29600 (131000)			3.18	III	30000 (133000)	5	<b>4F190</b>	305	(-)			
3.98	68700 (7760)		0.92	-	13100 (58500)	4.81	56900 (6430)	1.11	I	16500 (73400)	5	<b>4D16DC</b>	364				
			1.12	I	13100 (58500)			1.36	I	16500 (73400)	5	<b>4D17DC</b>	364				
			1.38	I	20300 (90400)			1.67	II	20900 (93100)	5	<b>4E17DC</b>	364				
			1.49	II	20300 (90400)			1.80	II	20900 (93100)	5	<b>4E18DB</b>	364				
			2.15	III	29200 (130000)			2.59	III	29700 (132000)	5	<b>4F18DB</b>	364				
			2.24	III	29200 (130000)			2.71	III	29700 (132000)	5	<b>4F19DB</b>	364				

Notes: [1] For Y4 Double Reductions (4XXXDX) refer to the above table; for Y4 single reduction refer to tables on pages 2.91-2.130.

[2] Variable Frequency Drive (VFD) notes (see page 2.8 for Constant Torque Speed Ranges):

All 1HP+ motors require EP suffix in model number and can be used with a VFD, unless noted.

(-) = For Inverter Operation, starting condition may require ambient temperature of 5° C or higher.

# Standard Mounting Selection Tables

**5 HP  
(3.7 kW)**

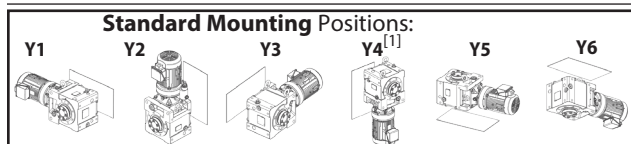

Dimension Pages:  
Single Reduction, Y2 2.132-2.143  
Single Reduction, Y2 2.144  
Double Reduction 2.146-2.161  
Double Reduction, Y2 2.162

Frequency	50 Hz	60 Hz
Input Speed	1450 RPM	1750 RPM
Number of Poles	4	

50Hz					60 Hz					Selection			VFD <sup>[2]</sup>	
Output Speed (RPM)	Output Torque		Service Factor		Solid Shaft Overhung Load		Output Speed (RPM)	Output Torque		Service Factor		Base		
	in-lbs	(N·m)	SF	AGMA Class	lbs	(N)		in-lbs	(N·m)	SF	AGMA Class	lbs	(N)	Motor Power Code
3.42	79900 (9030)		0.97	-	7810 (34700)	4.13	66200 (7480)	1.17	I	14000 (62100)	5	<b>4D17DC</b>	424	
			1.19	I	19800 (87900)			5	<b>4E17DC</b>	424				
			1.28	I	19800 (87900)			5	<b>4E18DB</b>	424				
			1.81	II	28700 (128000)			5	<b>4F18DB</b>	424				
			1.93	II	28700 (128000)			5	<b>4F19DB</b>	424				
2.90	94500 (10700)		1.00	I	19000 (84600)	3.50	78300 (8840)	1.21	I	19800 (88200)	5	<b>4E17DC</b>	501	
			1.09	I	19000 (84600)			5	<b>4E18DB</b>	501				
			1.56	II	28100 (125000)			5	<b>4F18DB</b>	501				
			1.63	II	28100 (125000)			5	<b>4F19DB</b>	501				
2.51	109000 (12300)		0.87	-	15000 (66600)	3.03	90300 (10200)	1.05	I	19200 (85500)	5	<b>4E17DC</b>	578	
			0.94	-	15000 (66600)			5	<b>4E18DB</b>	578				
			1.36	I	27500 (122000)			5	<b>4F18DB</b>	578				
			1.41	II	27500 (122000)			5	<b>4F19DB</b>	578				
2.12	129000 (14600)		1.15	I	26600 (118000)	2.56	107000 (12100)	1.39	I	27600 (123000)	5	<b>4F18DB</b>	683	
			1.20	I	26600 (118000)			5	<b>4F19DA</b>	683				
1.79	153000 (17200)		0.99	-	25600 (114000)	2.16	126000 (14300)	1.19	I	26700 (119000)	5	<b>4F18DB</b>	809	
			1.01	I	25600 (114000)			5	<b>4F19DA</b>	809				
1.52	180000 (20400)		0.84	-	22300 (99400)	1.83	149000 (16900)	1.01	I	25700 (114000)	5	<b>4F18DB</b>	956	
			0.85	-	22300 (99400)			5	<b>4F19DA</b>	956				

# Standard Mounting Selection Tables

**7.5 HP  
(5.5 kW)**

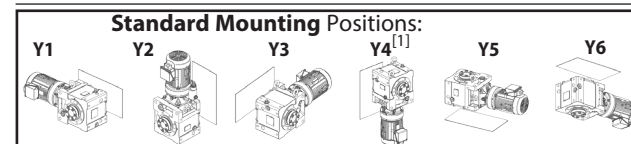

Dimension Pages:  
Single Reduction 2.132-2.143  
Single Reduction, Y2 2.144  
Double Reduction 2.146-2.161  
Double Reduction, Y2 2.162

Frequency	50 Hz	60 Hz
Input Speed	1450 RPM	1750 RPM
Number of Poles	4	

50Hz					60 Hz					Selection			VFD <sup>[2]</sup>	
Output Speed (RPM)	Output Torque		Service Factor		Solid Shaft Overhung Load		Output Speed (RPM)	Output Torque		Service Factor		Base		
	in-lbs	(N·m)	SF	AGMA Class	lbs	(N)		in-lbs	(N·m)	SF	AGMA Class	lbs	(N)	Motor Power Code
138	3100 (351)		1.75	II	3670 (16300)	167	2570 (291)	1.75	II	3520 (15600)	8	<b>4A120</b>	11	
			2.00	III	3670 (16300)			8	<b>4A125</b>	11				
			3.33	III	3700 (16500)			8	<b>4A145</b>	11				
113	3780 (428)		1.75	II	3830 (17000)	137	3140 (354)	1.75	II	3680 (16400)	8	<b>4A120</b>	13	
			2.00	III	3830 (17000)			8	<b>4A125</b>	13				
104	4140 (468)		1.75	II	3900 (17300)	125	3430 (387)	1.75	II	3750 (16700)	8	<b>4A120</b>	14	
			2.00	III	3900 (17300)			8	<b>4A125</b>	14				
			2.76	III	3910 (17400)			8	<b>4A140</b>	14				
90.6	4730 (534)		1.75	II	3980 (17700)	109	3920 (443)	1.75	II	3840 (17100)	8	<b>4A120</b>	16	
			2.00	III	3980 (17700)			8	<b>4A125</b>	16				
			2.41	III	4000 (17800)			8	<b>4A140</b>	16				
82.9	5170 (584)		1.75	II	4050 (18000)	100.0	4290 (484)	1.75	II	3910 (17400)	8	<b>4A120</b>	18	
			2.00	III	4050 (18000)			8	<b>4A125</b>	18				
			2.21	III	4060 (18100)			8	<b>4A140</b>	18				
69.0	6210 (701)		1.19	I	4190 (18600)	83.3	5140 (581)	1.19	I	4060 (18100)	8	<b>4A120</b>	21	
			1.37	I	4190 (18600)			8	<b>4A125</b>	21				
			1.84	II	4190 (18600)			8	<b>4A140</b>	21				
			2.36	III	6130 (27300)			8	<b>4B140</b>	21				
			2.75	III	6130 (27300)			8	<b>4B145</b>	21				
64.7	6620 (748)		1.19	I	4230 (18800)	78.1	5490 (620)	1.19	I	4110 (18300)	8	<b>4A120</b>	22	
			1.37	I	4230 (18800)			8	<b>4A125</b>	22				
			1.72	II	4230 (18800)			8	<b>4A140</b>	22				
			2.36	III	6220 (27700)			8	<b>4B140</b>	22				
			2.75	III	6220 (27700)			8	<b>4B145</b>	22				
59.2	7240 (818)		1.19	I	4290 (19100)	71.4	6000 (678)	1.19	I	4170 (18500)	8	<b>4A120</b>	25	
			1.37	I	4290 (19100)			8	<b>4A125</b>	25				
			1.58	II	4290 (19100)			8	<b>4A140</b>	25				
			2.36	III	6340 (28200)			8	<b>4B140</b>	25				
			2.75	III	6340 (28200)			8	<b>4B145</b>	25				
51.8	8280 (935)		1.19	I	4360 (19400)	62.5	6860 (775)	1.19	I	4250 (18900)	8	<b>4A120</b>	28	
			1.37	I	4360 (19400)			8	<b>4A125</b>	28				
			2.36	III	6520 (29000)			8	<b>4B140</b>	28				
			2.75	III	6520 (29000)			8	<b>4B145</b>	28				
41.2	10400 (1180)		1.08	I	3810 (17000)	49.7	8620 (974)	1.08	I	4380 (19500)	8	<b>4A125</b>	35	
			1.10	I	3810 (17000)			8	<b>4A140</b>	35				
			2.19	III	6820 (30300)			8	<b>4B140</b>	35				
			2.36	III	9930 (44200)			8	<b>4C140</b>	35				
			2.75	III	9930 (44200)			8	<b>4C145</b>	35				

Notes: [1] For Y4 Double Reductions (4XXXDX) refer to the above table; for Y4 single reduction refer to tables on pages 2.91-2.130.

[2] Variable Frequency Drive (VFD) notes (see page 2.8 for Constant Torque Speed Ranges):

All 1HP+ motors require EP suffix in model number and can be used with a VFD, unless noted.

Notes: [1] For Y4 Double Reductions (4XXXDX) refer to the above table; for Y4 single reduction refer to tables on pages 2.91-2.130..

[2] Variable Frequency Drive (VFD) notes (see page 2.8 for Constant Torque Speed Ranges):

All 1HP+ motors require EP suffix in model number and can be used with a VFD, unless noted.

# Standard Mounting Selection Tables

**7.5 HP  
(5.5 kW)**

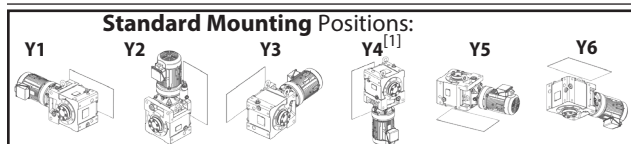

Dimension Pages:  
Single Reduction 2.132-2.143  
Single Reduction, Y2 2.144  
Double Reduction 2.146-2.161  
Double Reduction, Y2 2.162

Frequency	50 Hz	60 Hz
Input Speed	1450 RPM	1750 RPM
Number of Poles	4	

50Hz					60 Hz					Selection							
Output Speed (RPM)	Output Torque		Service Factor		Solid Shaft Overhung Load		Output Speed (RPM)	Output Torque		Service Factor		Solid Shaft Overhung Load		Base			VFD <sup>[2]</sup>
	in-lbs	(N·m)	SF	AGMA Class	lbs	(N)		in-lbs	(N·m)	SF	AGMA Class	lbs	(N)	Motor Power Code	Frame Size	Ratio	
37.7	11400 (1290)		1.00	I	3160 (14000)	45.5	9430 (1070)	1.00	I	4320 (19200)	8	<b>4A125</b>	39				
			1.08	I	6930 (30800)			1.08	I	6690 (29800)	8	<b>4B125</b>	39				
			2.00	III	6930 (30800)			2.00	III	6690 (29800)	8	<b>4B140</b>	39				
			2.36	III	10100 (45100)			2.36	III	9700 (43200)	8	<b>4C140</b>	39				
			2.75	III	10100 (45100)			2.75	III	9700 (43200)	8	<b>4C145</b>	39				
31.9	13400 (1520)		1.08	I	7120 (31700)	38.5	11100 (1260)	1.08	I	6900 (30700)	8	<b>4B125</b>	46				
			1.69	II	7120 (31700)			1.69	II	6900 (30700)	8	<b>4B140</b>	46				
			2.36	III	10500 (46800)			2.36	III	10100 (44900)	8	<b>4C140</b>	46				
			2.75	III	10500 (46800)			2.75	III	10100 (44900)	8	<b>4C145</b>	46				
27.6	15500 (1750)		1.08	I	7280 (32400)	33.3	12900 (1450)	1.08	I	7070 (31500)	8	<b>4B125</b>	53				
			1.47	II	7280 (32400)			1.47	II	7070 (31500)	8	<b>4B140</b>	53				
			2.18	III	10800 (48200)			2.18	III	10400 (46300)	8	<b>4C140</b>	53				
			2.63	III	10800 (48200)			2.65	III	10400 (46300)	8	<b>4C145</b>	53				
			2.86	III	10800 (48200)			2.93	III	10400 (46300)	8	<b>4C160</b>	53				
			2.93	III	10400 (46300)			2.93	III	10400 (46300)	8	<b>4C160</b>	53				
24.4	17600 (1990)		1.03	I	7400 (32900)	29.4	14600 (1650)	1.03	I	7210 (32100)	8	<b>4B125</b>	60				
			1.29	I	7400 (32900)			1.29	I	7210 (32100)	8	<b>4B140</b>	60				
			1.84	II	11100 (49400)			1.84	II	10700 (47600)	8	<b>4C140</b>	60				
			2.18	III	11100 (49400)			2.18	III	10700 (47600)	8	<b>4C145</b>	60				
			2.38	III	11100 (49400)			2.38	III	10700 (47600)	8	<b>4C160</b>	60				
			2.52	III	11100 (49400)			2.59	III	10700 (47600)	8	<b>4C165</b>	60				
21.6	19900 (2240)		1.15	I	6990 (31100)	26.0	16500 (1860)	1.15	I	7330 (32600)	8	<b>4B140</b>	67				
			1.57	II	11400 (50600)			1.57	II	11000 (48800)	8	<b>4C140</b>	67				
			1.72	II	11400 (50600)			1.99	II	11000 (48800)	8	<b>4C145</b>	67				
			2.29	III	11400 (50600)			2.29	III	11000 (48800)	8	<b>4C160</b>	67				
			2.35	III	17500 (77900)			2.35	III	16700 (74500)	8	<b>4D160</b>	67				
			2.91	III	17500 (77900)			2.93	III	16700 (74500)	8	<b>4D165</b>	67				
19.7	21700 (2450)		0.87	-	6220 (27700)	23.8	18000 (2030)	0.89	-	7420 (33000)	8	<b>4B125</b>	74				
			1.05	I	6220 (27700)			1.05	I	7420 (33000)	8	<b>4B140</b>	74				
			1.57	II	11600 (51400)			1.57	II	11200 (49600)	8	<b>4C140</b>	74				
			1.72	II	11600 (51400)			1.99	II	11200 (49600)	8	<b>4C145</b>	74				
			2.04	III	11600 (51400)			2.09	III	11200 (49600)	8	<b>4C160</b>	74				
			2.35	III	17900 (79600)			2.35	III	17100 (76100)	8	<b>4D160</b>	74				
			2.91	III	17900 (79600)			2.93	III	17100 (76100)	8	<b>4D165</b>	74				

Notes: [1] For Y4 Double Reductions (4XXXDX) refer to the above table; for Y4 single reduction refer to tables on pages 2.91-2.130.

[2] Variable Frequency Drive (VFD) notes (see page 2.8 for Constant Torque Speed Ranges):

All 1HP+ motors require EP suffix in model number and can be used with a VFD, unless noted.

# Standard Mounting Selection Tables

**7.5 HP  
(5.5 kW)**

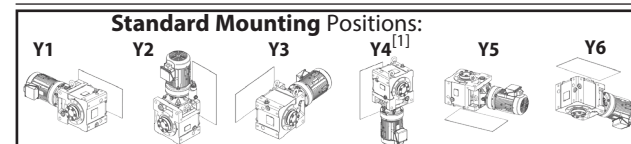

Dimension Pages:  
Single Reduction 2.132-2.143  
Single Reduction, Y2 2.144  
Double Reduction 2.146-2.161  
Double Reduction, Y2 2.162

Frequency	50 Hz	60 Hz
Input Speed	1450 RPM	1750 RPM
Number of Poles	4	

50Hz					60 Hz					Selection							
Output Speed (RPM)	Output Torque		Service Factor		Solid Shaft Overhung Load		Output Speed (RPM)	Output Torque		Service Factor		Solid Shaft Overhung Load		Base			VFD <sup>[2]</sup>
	in-lbs	(N·m)	SF	AGMA Class	lbs	(N)		in-lbs	(N·m)	SF	AGMA Class	lbs	(N)	Motor Power Code	Frame Size	Ratio	
18.1	23600 (2670)		1.25	I	11700 (52100)	21.9	19600 (2210)	1.25	I	11300 (50400)	8	<b>4C140</b>	80				
			1.44	II	11700 (52100)			1.44	II	11300 (50400)	8	<b>4C145</b>	80				
			1.79	II	11700 (52100)			1.79	II	11300 (50400)	8	<b>4C160</b>	80				
			1.92	II	11700 (52100)			1.92	II	11300 (50400)	8	<b>4C165</b>	80				
			2.44	III	18200 (81200)			2.44	III	17500 (77700)	8	<b>4D165</b>	80				
			2.83	III	18200 (81200)			2.83	III	17500 (77700)	8	<b>4D170</b>	80				
16.6	25900 (2920)		0.88	-	3570 (15900)	20.0	21400 (2420)	0.88	-	6350 (28300)	8	<b>4B140</b>	88				
			1.25	I	11900 (52900)			1.25	I	11500 (51300)	8	<b>4C140</b>	88				
			1.44	II	11900 (52900)			1.44	II	11500 (51300)	8	<b>4C145</b>	88				
			1.72	II	11900 (52900)			1.72	II	11500 (51300)	8	<b>4C160</b>	88				
			1.79	II	18600 (82800)			1.79	II	17800 (79300)	8	<b>4D160</b>	88				
			2.44	III	18600 (82800)			2.44	III	17800 (79300)	8	<b>4D165</b>	88				
			2.83	III	18600 (82800)			2.83	III	17800 (79300)	8	<b>4D170</b>	88				
			2.98	III	18600 (82800)			2.98	III	17800 (79300)	8	<b>4D175</b>	88				
			2.98	III	18600 (82800)			3.60	III	17800 (79300)	8	<b>4D180</b>	88				
			3.60	III	17800 (79300)			3.60	III	17800 (79300)	8	<b>4D180</b>	88				
14.3	30000 (3390)		1.08	I	12200 (54000)	17.2	24900 (2810)	1.08	I	11800 (52600)	8	<b>4C140</b>	102				
			1.37	I	12200 (54000)			1.37	I	11800 (52600)	8	<b>4C145</b>	102				
			1.48	II	12200 (54000)			1.52	II	11800 (52600)	8	<b>4C160</b>	102				
			1.74	II	19200 (85500)			1.91	II	18500 (82100)	8	<b>4D160</b>	102				
			2.07	III	19200 (85500)			2.07	III	18500 (82100)	8	<b>4D165</b>	102				
			2.45	III	19200 (85500)			2.57	III	18500 (82100)	8	<b>4D170</b>	102				
			2.57	III	19200 (85500)			2.57	III	18500 (82100)	8	<b>4D175</b>	102				
			2.57	III	19200 (85500)			3.10	III	18500 (82100)	8	<b>4D180</b>	102				
			2.90	III	22300 (99100)			2.90	III	22500 (100000)	8	<b>4E175</b>	102				
			2.90	III	22300 (99100)			3.50	III	22500 (100000)	8	<b>4E180</b>	102				
12.9	33100 (3740)		1.14	I	12300 (54700)	15.6	27400 (3100)	1.37	I	12000 (53300)	8	<b>4C145</b>	112				
			1.37	I	12300 (54700)			1.37	I	12000 (53300)	8	<b>4C160</b>	112				
			1.46	II	19600 (87300)			1.76	II	18900 (83900)	8	<b>4D160</b>	112				
			1.74	II	19600 (87300)			2.07	III	18900 (83900)	8	<b>4D165</b>	112				
			2.03	III	19600 (87300)			2.18	III	18900 (83900)	8	<b>4D170</b>	112				
			2.33	III	19600 (87300)			2.33	III	18900 (83900)	8	<b>4D175</b>	112				
			2.33	III	19600 (87300)			2.81	III	18900 (83900)	8	<b>4D180</b>	112				
			2.33	III	19600 (87300)			2.81	III	18900 (83900)	8	<b>4D180</b>	112				
			2.62	III	22100 (98400)			2.75	III	22400 (99700)	8	<b>4E175</b>	112				
			2.75	III	22100 (98400)			2.75	III	22400 (99700)	8	<b>4E175</b>	112				

Notes: [1] For Y4 Double Reductions (4XXXDX) refer to the above table; for Y4 single reduction refer to tables on pages 2.91-2.130.

[2] Variable Frequency Drive (VFD) notes (see page 2.8 for Constant Torque Speed Ranges):

All 1HP+ motors require EP suffix in model number and can be used with a VFD, unless noted.

(-) = For Inverter Operation, starting condition may require ambient temperature of 5° C or higher.

# Standard Mounting Selection Tables

**7.5 HP  
(5.5 kW)**

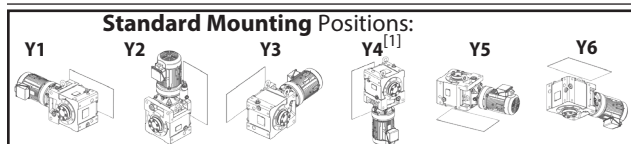

Dimension Pages:  
Single Reduction 2.132-2.143  
Single Reduction, Y2 2.144  
Double Reduction 2.146-2.161  
Double Reduction, Y2 2.162

Frequency	50 Hz	60 Hz
Input Speed	1450 RPM	1750 RPM
Number of Poles	4	

50Hz					60 Hz					Selection							
Output Speed (RPM)	Output Torque		Service Factor		Solid Shaft Overhung Load		Output Speed (RPM)	Output Torque		Service Factor		Solid Shaft Overhung Load		Base			VFD <sup>[2]</sup>
	in-lbs	(N·m)	SF	AGMA Class	lbs	(N)		in-lbs	(N·m)	SF	AGMA Class	lbs	(N)	Motor Power Code	Frame Size	Ratio	
11.8	36200 (4090)		0.95	-	12300 (54800)	14.3	30000 (3390)	0.95	-	12200 (54000)	8	<b>4C140</b>	123				
			1.14	I	12300 (54800)			1.26	I	12200 (54000)	8	<b>4C145</b>	123				
			1.46	II	20000 (88900)			1.76	II	19200 (85500)	8	<b>4D160</b>	123				
			1.74	II	20000 (88900)			2.07	III	19200 (85500)	8	<b>4D165</b>	123				
			2.03	III	20000 (88900)			2.13	III	19200 (85500)	8	<b>4D170</b>	123				
			2.13	III	20000 (88900)			2.13	III	19200 (85500)	8	<b>4D175</b>	123				
			2.13	III	20000 (88900)			2.57	III	19200 (85500)	8	<b>4D180</b>	123				(-)
			2.62	III	22000 (97700)			2.75	III	22300 (99100)	8	<b>4E175</b>	123				
			2.84	III	22000 (97700)			3.42	III	22300 (99100)	8	<b>4E180</b>	123				(-)
			2.84	III	22000 (97700)			3.42	III	22300 (99100)	8	<b>4E185</b>	123				(-)
9.63	44500 (5030)		0.85	-	9820 (43700)	11.6	36900 (4160)	0.98	-	12200 (54100)	8	<b>4C145</b>	151				
			1.00	I	9820 (43700)			1.02	I	12200 (54100)	8	<b>4C160</b>	151				
			1.17	I	19200 (85500)			1.35	I	20100 (89200)	8	<b>4D160</b>	151				
			1.42	II	19200 (85500)			1.44	II	20100 (89200)	8	<b>4D165</b>	151				
			1.65	II	19200 (85500)			1.73	II	20100 (89200)	8	<b>4D170</b>	151				
			1.73	II	19200 (85500)			1.73	II	20100 (89200)	8	<b>4D175</b>	151				
			1.73	II	19200 (85500)			2.09	III	20100 (89200)	8	<b>4D180</b>	151				(-)
			2.05	III	21600 (95900)			2.05	III	21900 (97600)	8	<b>4E175</b>	151				
			2.31	III	21600 (95900)			2.75	III	21900 (97600)	8	<b>4E180</b>	151				(-)
			2.31	III	21600 (95900)			2.79	III	21900 (97600)	8	<b>4E185</b>	151				(-)
2.74	III	30200 (135000)	2.75	III	30600 (136000)	8	<b>4F180</b>	151	(-)								
8.12	52800 (5960)		0.84	-	5440 (24200)	9.80	43700 (4940)	0.86	-	10100 (44900)	8	<b>4C160</b>	179				
			1.00	I	17900 (79700)			1.05	I	19300 (86000)	8	<b>4D160</b>	179				
			1.20	I	17900 (79700)			1.37	I	19300 (86000)	8	<b>4D165</b>	179				
			1.39	I	17900 (79700)			1.46	II	19300 (86000)	8	<b>4D170</b>	179				
			1.46	II	17900 (79700)			1.46	II	19300 (86000)	8	<b>4D175</b>	179				
			1.46	II	17900 (79700)			1.77	II	19300 (86000)	8	<b>4D180</b>	179				
			1.79	II	21100 (94000)			1.95	II	21600 (96000)	8	<b>4E175</b>	179				
			1.95	II	21100 (94000)			2.18	III	21600 (96000)	8	<b>4E180</b>	179				
			1.95	II	21100 (94000)			2.35	III	21600 (96000)	8	<b>4E185</b>	179				
			2.18	III	29900 (133000)			2.18	III	30300 (135000)	8	<b>4F180</b>	179				
2.75	III	29900 (133000)	2.75	III	30300 (135000)	8	<b>4F185</b>	179									

Notes: [1] For Y4 Double Reductions (4XXXDX) refer to the above table; for Y4 single reduction refer to tables on pages 2.91-2.130.

[2] Variable Frequency Drive (VFD) notes (see page 2.8 for Constant Torque Speed Ranges):

All 1HP+ motors require EP suffix in model number and can be used with a VFD, unless noted.

(-) = For Inverter Operation, starting condition may require ambient temperature of 5° C or higher.

# Standard Mounting Selection Tables

**7.5 HP  
(5.5 kW)**

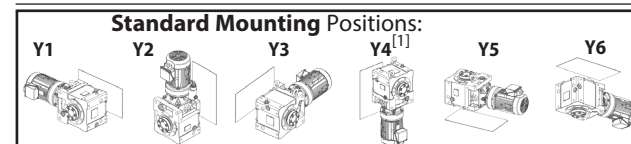

Dimension Pages:  
Single Reduction 2.132-2.143  
Single Reduction, Y2 2.144  
Double Reduction 2.146-2.161  
Double Reduction, Y2 2.162

Frequency	50 Hz	60 Hz
Input Speed	1450 RPM	1750 RPM
Number of Poles	4	

50Hz					60 Hz					Selection														
Output Speed (RPM)	Output Torque		Service Factor		Solid Shaft Overhung Load		Output Speed (RPM)	Output Torque		Service Factor		Solid Shaft Overhung Load		Base			VFD <sup>[2]</sup>							
	in-lbs	(N·m)	SF	AGMA Class	lbs	(N)		in-lbs	(N·m)	SF	AGMA Class	lbs	(N)	Motor Power Code	Frame Size	Ratio								
7.02	61000 (6900)		0.80	-	16300 (72300)	8.47	50600 (5710)	0.80	-	18300 (81400)	8	<b>4D160</b>	207											
			1.03	I	16300 (72300)			1.05	I	18300 (81400)	8	<b>4D165</b>	207											
			1.20	I	16300 (72300)			1.26	I	18300 (81400)	8	<b>4D170</b>	207											
			1.26	I	16300 (72300)			1.26	I	18300 (81400)	8	<b>4D175</b>	207											
			1.26	I	16300 (72300)			1.53	II	18300 (81400)	8	<b>4D180</b>	207											
			1.51	II	20700 (92100)			1.51	II	21200 (94500)	8	<b>4E175</b>	207											
			1.68	II	20700 (92100)			1.77	II	21200 (94500)	8	<b>4E180</b>	207											
			1.68	II	20700 (92100)			2.03	III	21200 (94500)	8	<b>4E185</b>	207											
			1.77	II	29500 (131000)			1.77	II	30000 (133000)	8	<b>4F180</b>	207											
			2.18	III	29500 (131000)			2.18	III	30000 (133000)	8	<b>4F185</b>	207											
			2.61	III	29500 (131000)			2.78	III	30000 (133000)	8	<b>4F190</b>	207				(-)							
			2.61	III	29500 (131000)			3.15	III	30000 (133000)	8	<b>4F195</b>	207				(-)							
			5.84	73500 (8300)				0.86	-	12800 (56900)	7.04	60900 (6880)	1.03				I	16300 (72500)	8	<b>4D165</b>	249			
1.05	I	12800 (56900)				1.05	I	16300 (72500)	8	<b>4D175</b>			249											
1.05	I	12800 (56900)				1.27	I	16300 (72500)	8	<b>4D180</b>			249											
1.27	I	20100 (89300)				1.30	I	20700 (92200)	8	<b>4E175</b>			249											
1.40	II	20100 (89300)				1.60	II	20700 (92200)	8	<b>4E180</b>			249											
1.40	II	20100 (89300)				1.69	II	20700 (92200)	8	<b>4E185</b>			249											
1.60	II	29000 (129000)				1.60	II	29500 (131000)	8	<b>4F180</b>			249											
1.78	II	29000 (129000)				1.78	II	29500 (131000)	8	<b>4F185</b>			249											
2.17	III	29000 (129000)				2.45	III	29500 (131000)	8	<b>4F190</b>			249	(-)										
2.17	III	29000 (129000)				2.62	III	29500 (131000)	8	<b>4F195</b>			249	(-)										
4.76	90000 (10200)					0.86	-	272 (1210)	5.75	74600 (8430)			0.86	-	12400 (55100)	8	<b>4D175</b>	305						
						0.86	-	272 (1210)					1.03	I	12400 (55100)	8	<b>4D180</b>	305						
						1.02	I	19200 (85600)					1.02	I	20000 (89100)	8	<b>4E175</b>	305						
			1.14	I	19200 (85600)	1.30	I	20000 (89100)			8	<b>4E180</b>	305											
			1.14	I	19200 (85600)	1.38	I	20000 (89100)			8	<b>4E185</b>	305											
			1.30	I	28300 (126000)	1.30	I	28900 (129000)			8	<b>4F180</b>	305											
			1.56	II	28300 (126000)	1.56	II	28900 (129000)			8	<b>4F185</b>	305											
			1.77	II	28300 (126000)	2.14	III	28900 (129000)			8	<b>4F190</b>	305	(-)										
3.98	102000 (11500)		0.93	-	17200 (76300)	4.81	84600 (9560)	1.12	I	19500 (86800)	8	<b>4E17DC</b>	364											
			1.01	I	17200 (76300)			1.21	I	19500 (86800)	8	<b>4E18DB</b>	364											
			1.45	II	27800 (123000)			1.74	II	28500 (127000)	8	<b>4F18DB</b>	364											
			1.51	II	27800 (123000)			1.82	II	28500 (127000)	8	<b>4F19DB</b>	364											
3.42	119000 (13400)		0.86	-	10800 (47900)	4.13	98400 (11100)	1.04	I	18200 (80800)	8	<b>4E18DB</b>	424											
			1.22	I	27000 (120000)			1.47	II	27900 (124000)	8	<b>4F18DB</b>	424											
			1.30	I	27000 (120000)			1.56	II	27900 (124000)	8	<b>4F19DB</b>	424											

Notes: [1] For Y4 Double Reductions (4XXXDX) refer to the above table; for Y4 single reduction refer to tables on pages 2.91-2.130.

[2] Variable Frequency Drive (VFD) notes (see page 2.8 for Constant Torque Speed Ranges):

All 1HP+ motors require EP suffix in model number and can be used with a VFD, unless noted.

(-) = For Inverter Operation, starting condition may require ambient temperature of 5° C or higher.



# Standard Mounting Selection Tables

**7.5 HP  
(5.5 kW)**

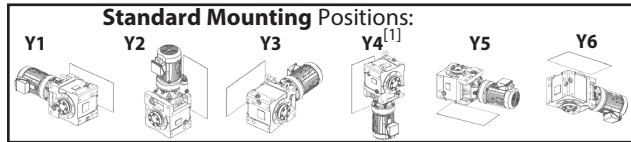

Dimension Pages:  
 Single Reduction, Y2 2.132-2.143  
 Single Reduction, Y2 2.144  
 Double Reduction 2.146-2.161  
 Double Reduction, Y2 2.162

Frequency	50 Hz	60 Hz
Input Speed	1450 RPM	1750 RPM
Number of Poles	4	

50Hz				60 Hz				Selection			VFD <sup>[2]</sup>			
Output Speed (RPM)	Output Torque		Service Factor	Solid Shaft Overhung Load		Output Speed (RPM)	Output Torque		Service Factor	Base				
	in-lbs	(N·m)		lbs	(N)		in-lbs	(N·m)		SF	AGMA Class	lbs	(N)	Motor Power Code
2.90	140000 (15900)		1.05	I	26100 (116000)	3.50	116000 (13100)		1.27	I	27100 (121000)	8	4F18DB	501
			1.10	I	26100 (116000)				1.32	I	27100 (121000)			
2.51	162000 (18300)		0.92	-	25200 (112000)	3.03	134000 (15200)		1.10	I	26400 (117000)	8	4F18DB	578
			0.95	-	25200 (112000)				1.15	I	26400 (117000)			
2.12	191000 (21600)		0.80	-	17800 (79200)	2.56	159000 (17900)		0.97	-	25300 (113000)	8	4F19DA	683

# Standard Mounting Selection Tables

**10 HP  
(7.5 kW)**

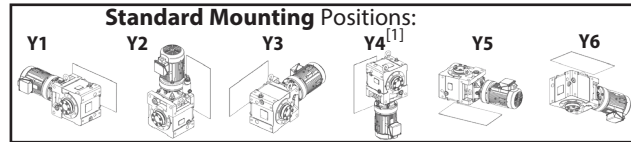

Dimension Pages:  
 Single Reduction 2.132-2.143  
 Single Reduction, Y2 2.144  
 Double Reduction 2.146-2.161  
 Double Reduction, Y2 2.162

Frequency	50 Hz	60 Hz
Input Speed	1450 RPM	1750 RPM
Number of Poles	4	

50Hz				60 Hz				Selection			VFD <sup>[2]</sup>			
Output Speed (RPM)	Output Torque		Service Factor	Solid Shaft Overhung Load		Output Speed (RPM)	Output Torque		Service Factor	Base				
	in-lbs	(N·m)		lbs	(N)		in-lbs	(N·m)		SF	AGMA Class	lbs	(N)	Motor Power Code
138	4230 (478)		2.44	III	3540 (15700)	167	3510 (396)		2.53	III	3410 (15200)	10	4A140	11
			2.53	III	5110 (22700)				2.53	III	4880 (21700)			
			2.93	III	5110 (22700)				2.93	III	4880 (21700)			
113	5160 (583)		2.21	III	3640 (16200)	137	4280 (483)		2.21	III	3530 (15700)	10	4A140	13
			2.53	III	5320 (23700)				2.53	III	5090 (22600)			
			2.93	III	5320 (23700)				2.93	III	5090 (22600)			
104	5640 (638)		2.02	III	3700 (16400)	125	4680 (528)		2.02	III	3590 (15900)	10	4A140	14
			2.53	III	5430 (24100)				2.53	III	5200 (23100)			
			2.93	III	5430 (24100)				2.93	III	5200 (23100)			
90.6	6450 (729)		1.77	II	3760 (16700)	109	5340 (604)		1.77	II	3660 (16300)	10	4A140	16
			2.53	III	5570 (24800)				2.53	III	5350 (23800)			
			2.93	III	5570 (24800)				2.93	III	5350 (23800)			
82.9	7050 (797)		1.62	II	3810 (16900)	100.0	5840 (660)		1.62	II	3710 (16500)	10	4A140	18
			2.53	III	5680 (25300)				2.53	III	5450 (24300)			
			2.93	III	5680 (25300)				2.93	III	5450 (24300)			
69.0	8470 (956)		1.35	I	3880 (17300)	83.3	7010 (792)		1.35	I	3800 (16900)	10	4A140	21
			1.73	II	5890 (26200)				1.73	II	5670 (25200)			
			2.01	III	5890 (26200)				2.01	III	5670 (25200)			
			2.69	III	5890 (26200)				2.69	III	5670 (25200)			
64.7	9030 (1020)		1.26	I	3900 (17400)	78.1	7480 (845)		1.26	I	3830 (17000)	10	4A140	22
			1.73	II	5960 (26500)				1.73	II	5740 (25600)			
			2.01	III	5960 (26500)				2.01	III	5740 (25600)			
			2.52	III	5960 (26500)				2.52	III	5740 (25600)			
			2.71	III	8670 (38600)				2.71	III	8300 (36900)			
59.2	9880 (1120)		1.16	I	3930 (17500)	71.4	8180 (925)		1.16	I	3870 (17200)	10	4A140	25
			1.73	II	6060 (26900)				1.73	II	5850 (26000)			
			2.01	III	6060 (26900)				2.01	III	5850 (26000)			
			2.30	III	6060 (26900)				2.30	III	5850 (26000)			
			2.71	III	8850 (39400)				2.71	III	8480 (37700)			
51.8	11300 (1280)		1.01	I	3230 (14400)	62.5	9350 (1060)		1.01	I	3910 (17400)	10	4A140	28
			1.73	II	6200 (27600)				1.73	II	6000 (26700)			
			2.01	III	6200 (27600)				2.01	III	6000 (26700)			
			2.63	III	9120 (40600)				2.63	III	8740 (38900)			
41.2	14200 (1600)		1.60	II	6410 (28500)	49.7	11800 (1330)		1.60	II	6230 (27700)	10	4B140	35
			1.73	II	9570 (42600)				1.73	II	9200 (40900)			
			2.01	III	9570 (42600)				2.01	III	9200 (40900)			
			2.63	III	9570 (42600)				2.63	III	9200 (40900)			

Notes: [1] For Y4 Double Reductions (4XXXDX) refer to the above table; for Y4 single reduction refer to tables on pages 2.91-2.130.  
 [2] Variable Frequency Drive (VFD) notes (see page 2.8 for Constant Torque Speed Ranges):  
 All 1HP+ motors require EP suffix in model number and can be used with a VFD, unless noted.

Notes: [1] For Y4 Double Reductions (4XXXDX) refer to the above table; for Y4 single reduction refer to tables on pages 2.91-2.130..  
 [2] Variable Frequency Drive (VFD) notes (see page 2.8 for Constant Torque Speed Ranges):  
 All 1HP+ motors require EP suffix in model number and can be used with a VFD, unless noted.

Cyclo® BBB4  
Selection Tables

Cyclo® BBB4  
Selection Tables

# Standard Mounting Selection Tables

**10 HP  
(7.5 kW)**

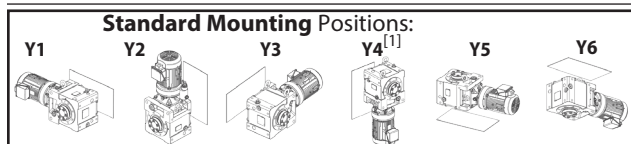

Dimension Pages:  
Single Reduction 2.132-2.143  
Single Reduction, Y2 2.144  
Double Reduction 2.146-2.161  
Double Reduction, Y2 2.162

Frequency	50 Hz	60 Hz
Input Speed	1450 RPM	1750 RPM
Number of Poles	4	

50Hz					60 Hz					Selection							
Output Speed (RPM)	Output Torque		Service Factor		Solid Shaft Overhung Load		Output Speed (RPM)	Output Torque		Service Factor		Solid Shaft Overhung Load		Base			VFD <sup>[2]</sup>
	in-lbs	(N·m)	SF	AGMA Class	lbs	(N)		in-lbs	(N·m)	SF	AGMA Class	lbs	(N)	Motor Power Code	Frame Size	Ratio	
37.7	15500 (1750)		1.47	II	6480 (28800)	45.5	12900 (1450)	1.47	II	6320 (28100)	10	<b>4B140</b>	39				
			1.73	II	9740 (43300)			1.73	II	9380 (41700)	10	<b>4C140</b>	39				
			2.01	III	9740 (43300)			2.01	III	9380 (41700)	10	<b>4C145</b>	39				
			2.63	III	9740 (43300)			2.63	III	9380 (41700)	10	<b>4C160</b>	39				
			2.86	III	9740 (43300)			2.93	III	9380 (41700)	10	<b>4C165</b>	39				
31.9	18300 (2070)		1.24	I	6600 (29300)	38.5	15200 (1720)	1.24	I	6470 (28800)	10	<b>4B140</b>	46				
			1.73	II	10000 (44700)			1.73	II	9700 (43100)	10	<b>4C140</b>	46				
			2.01	III	10000 (44700)			2.01	III	9700 (43100)	10	<b>4C145</b>	46				
			2.42	III	10000 (44700)			2.48	III	9700 (43100)	10	<b>4C160</b>	46				
			2.63	III	15500 (69100)			2.63	III	14900 (66100)	10	<b>4D160</b>	46				
27.6	21200 (2390)		1.07	I	6470 (28800)	33.3	17500 (1980)	1.07	I	6570 (29200)	10	<b>4B140</b>	53				
			1.60	II	10300 (45800)			1.60	II	9970 (44300)	10	<b>4C140</b>	53				
			1.93	II	10300 (45800)			1.94	II	9970 (44300)	10	<b>4C145</b>	53				
			2.10	III	10300 (45800)			2.15	III	9970 (44300)	10	<b>4C160</b>	53				
			2.49	III	16100 (71400)			2.49	III	15400 (68400)	10	<b>4D160</b>	53				
			2.98	III	16100 (71400)			3.01	III	15400 (68400)	10	<b>4D165</b>	53				
24.4	24000 (2710)		0.95	-	5010 (22300)	29.4	19900 (2250)	0.95	-	6640 (29500)	10	<b>4B140</b>	60				
			1.35	I	10500 (46700)			1.35	I	10200 (45300)	10	<b>4C140</b>	60				
			1.60	II	10500 (46700)			1.60	II	10200 (45300)	10	<b>4C145</b>	60				
			1.75	II	10500 (46700)			1.75	II	10200 (45300)	10	<b>4C160</b>	60				
			1.85	II	10500 (46700)			1.90	II	10200 (45300)	10	<b>4C165</b>	60				
			2.51	III	16500 (73400)			2.51	III	15800 (70400)	10	<b>4D165</b>	60				
21.6	27100 (3060)		1.15	I	10700 (47500)	26.0	22400 (2540)	1.15	I	10400 (46200)	10	<b>4C140</b>	67				
			1.26	I	10700 (47500)			1.46	II	10400 (46200)	10	<b>4C145</b>	67				
			1.68	II	10700 (47500)			1.68	II	10400 (46200)	10	<b>4C160</b>	67				
			1.72	II	16900 (75400)			1.72	II	16300 (72400)	10	<b>4D160</b>	67				
			2.13	III	16900 (75400)			2.15	III	16300 (72400)	10	<b>4D165</b>	67				
			2.48	III	16900 (75400)			2.60	III	16300 (72400)	10	<b>4D170</b>	67				
			2.85	III	16900 (75400)			2.85	III	16300 (72400)	10	<b>4D175</b>	67				
			2.85	III	16900 (75400)			3.44	III	16300 (72400)	10	<b>4D180</b>	67				

Notes: [1] For Y4 Double Reductions (4XXXDX) refer to the above table; for Y4 single reduction refer to tables on pages 2.91-2.130.

[2] Variable Frequency Drive (VFD) notes (see page 2.8 for Constant Torque Speed Ranges):

All 1HP+ motors require EP suffix in model number and can be used with a VFD, unless noted.

(-) = For Inverter Operation, starting condition may require ambient temperature of 5° C or higher.

# Standard Mounting Selection Tables

**10 HP  
(7.5 kW)**

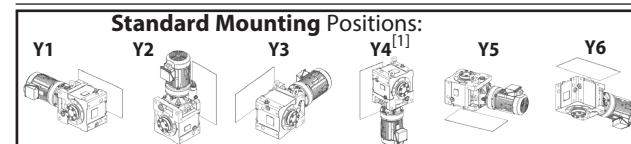

Dimension Pages:  
Single Reduction 2.132-2.143  
Single Reduction, Y2 2.144  
Double Reduction 2.146-2.161  
Double Reduction, Y2 2.162

Frequency	50 Hz	60 Hz
Input Speed	1450 RPM	1750 RPM
Number of Poles	4	

50Hz					60 Hz					Selection							
Output Speed (RPM)	Output Torque		Service Factor		Solid Shaft Overhung Load		Output Speed (RPM)	Output Torque		Service Factor		Solid Shaft Overhung Load		Base			VFD <sup>[2]</sup>
	in-lbs	(N·m)	SF	AGMA Class	lbs	(N)		in-lbs	(N·m)	SF	AGMA Class	lbs	(N)	Motor Power Code	Frame Size	Ratio	
19.7	29600 (3350)		1.15	I	10800 (48100)	23.8	24500 (2770)	1.15	I	10500 (46900)	10	<b>4C140</b>	74				
			1.26	I	10800 (48100)			1.46	II	10500 (46900)	10	<b>4C145</b>	74				
			1.50	II	10800 (48100)			1.54	II	10500 (46900)	10	<b>4C160</b>	74				
			1.72	II	17300 (76800)			1.72	II	16600 (73800)	10	<b>4D160</b>	74				
			2.13	III	17300 (76800)			2.15	III	16600 (73800)	10	<b>4D165</b>	74				
			2.48	III	17300 (76800)			2.60	III	16600 (73800)	10	<b>4D170</b>	74				
			2.60	III	17300 (76800)			2.60	III	16600 (73800)	10	<b>4D175</b>	74				
			2.60	III	17300 (76800)			3.14	III	16600 (73800)	10	<b>4D180</b>	74			(-)	
			2.94	III	22300 (99200)			2.94	III	22000 (98000)	10	<b>4E175</b>	74				
			2.94	III	22300 (99200)			3.54	III	22000 (98000)	10	<b>4E180</b>	74			(-)	
18.1	32200 (3640)		1.05	I	10900 (48500)	21.9	26700 (3020)	1.05	I	10700 (47400)	10	<b>4C145</b>	80				
			1.31	I	10900 (48500)			1.31	I	10700 (47400)	10	<b>4C160</b>	80				
			1.41	II	10900 (48500)			1.41	II	10700 (47400)	10	<b>4C165</b>	80				
			1.79	II	17600 (78100)			2.01	III	16900 (75100)	10	<b>4D165</b>	80				
			2.08	III	17600 (78100)			2.11	III	16900 (75100)	10	<b>4D170</b>	80				
			2.39	III	17600 (78100)			2.39	III	16900 (75100)	10	<b>4D175</b>	80				
			2.39	III	17600 (78100)			2.89	III	16900 (75100)	10	<b>4D180</b>	80			(-)	
			2.60	III	22200 (98600)			2.60	III	22500 (99900)	10	<b>4E175</b>	80				
			2.70	III	22200 (98600)			3.21	III	22500 (99900)	10	<b>4E180</b>	80			(-)	
			2.70	III	22200 (98600)			3.26	III	22500 (99900)	10	<b>4E185</b>	80			(-)	
16.6	35300 (3990)		1.05	I	11000 (48900)	20.0	29200 (3300)	1.05	I	10800 (48000)	10	<b>4C145</b>	88				
			1.26	I	11000 (48900)			1.29	I	10800 (48000)	10	<b>4C160</b>	88				
			1.31	I	17900 (79400)			1.31	I	17200 (76600)	10	<b>4D160</b>	88				
			1.79	II	17900 (79400)			2.01	III	17200 (76600)	10	<b>4D165</b>	88				
			2.08	III	17900 (79400)			2.11	III	17200 (76600)	10	<b>4D170</b>	88				
			2.19	III	17900 (79400)			2.19	III	17200 (76600)	10	<b>4D175</b>	88				
			2.19	III	17900 (79400)			2.64	III	17200 (76600)	10	<b>4D180</b>	88			(-)	
			2.47	III	22000 (97900)			2.47	III	22300 (99300)	10	<b>4E175</b>	88				
			2.47	III	22000 (97900)			2.98	III	22300 (99300)	10	<b>4E180</b>	88			(-)	
			2.47	III	22000 (97900)			2.98	III	22300 (99300)	10	<b>4E185</b>	88			(-)	
2.47	III	22000 (97900)	2.98	III	22300 (99300)	10	<b>4E190</b>	88	(-)								
2.47	III	22000 (97900)	2.98	III	22300 (99300)	10	<b>4E195</b>	88	(-)								

Notes: [1] For Y4 Double Reductions (4XXXDX) refer to the above table; for Y4 single reduction refer to tables on pages 2.91-2.130.

[2] Variable Frequency Drive (VFD) notes (see page 2.8 for Constant Torque Speed Ranges):

All 1HP+ motors require EP suffix in model number and can be used with a VFD, unless noted.

(-) = For Inverter Operation, starting condition may require ambient temperature of 5° C or higher.

# Standard Mounting Selection Tables

**10 HP  
(7.5 kW)**

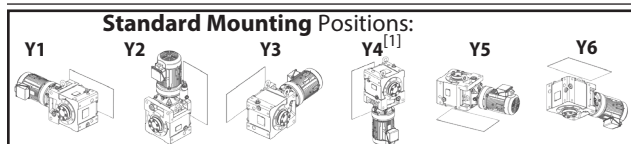

Dimension Pages:  
Single Reduction, Y2 2.132-2.143  
Single Reduction, Y2 2.144  
Double Reduction 2.146-2.161  
Double Reduction, Y2 2.162

Frequency	50 Hz	60 Hz
Input Speed	1450 RPM	1750 RPM
Number of Poles	4	

50Hz					60 Hz					Selection										
Output Speed (RPM)	Output Torque		Service Factor		Solid Shaft Overhung Load		Output Speed (RPM)	Output Torque		Service Factor		Solid Shaft Overhung Load		Base			VFD <sup>[2]</sup>			
	in-lbs	(N·m)	SF	AGMA Class	lbs	(N)		in-lbs	(N·m)	SF	AGMA Class	lbs	(N)	Motor Power Code	Frame Size	Ratio				
14.3	40900 (4620)		1.00	I	11000 (49100)	17.2	33900 (3830)		1.00	I	11000 (48700)	10	4C145	102						
			1.08	I	11000 (49100)				1.11	I	11000 (48700)						10	4C160	102	
			1.27	I	18300 (81600)				1.40	II	17700 (78800)						10	4D160	102	
			1.52	II	18300 (81600)				1.52	II	17700 (78800)						10	4D165	102	
			1.79	II	18300 (81600)				1.89	II	17700 (78800)						10	4D170	102	
			1.89	II	18300 (81600)				1.89	II	17700 (78800)						10	4D175	102	
			1.89	II	18300 (81600)				2.28	III	17700 (78800)						10	4D180	102	(-)
			2.13	III	21700 (96700)				2.13	III	22100 (98300)						10	4E175	102	
			2.13	III	21700 (96700)				2.57	III	22100 (98300)						10	4E180	102	(-)
			2.13	III	21700 (96700)				2.57	III	22100 (98300)						10	4E185	102	(-)
			2.13	III	21700 (96700)				2.57	III	22100 (98300)						10	4E190	102	(-)
			2.13	III	21700 (96700)				2.57	III	22100 (98300)						10	4E195	102	(-)
			2.60	III	30400 (135000)				2.60	III	30700 (137000)						10	4F180	102	(-)
12.9	45100 (5100)		1.01	I	9560 (42500)	15.6	37400 (4230)		1.01	I	11000 (49100)	10	4C160	112						
			1.07	I	18700 (83000)				1.29	I	18100 (80300)						10	4D160	112	
			1.28	I	18700 (83000)				1.52	II	18100 (80300)						10	4D165	112	
			1.49	II	18700 (83000)				1.60	II	18100 (80300)						10	4D170	112	
			1.71	II	18700 (83000)				1.71	II	18100 (80300)						10	4D175	112	
			1.71	II	18700 (83000)				2.06	III	18100 (80300)						10	4D180	112	(-)
			1.92	II	21500 (95700)				2.01	III	21900 (97500)						10	4E175	112	
			2.27	III	21500 (95700)				2.51	III	21900 (97500)						10	4E180	112	(-)
			2.27	III	21500 (95700)				2.74	III	21900 (97500)						10	4E185	112	(-)
			2.47	III	30200 (134000)				2.51	III	30600 (136000)						10	4F180	112	(-)
			11.8	49400 (5580)					0.83	-	7640 (34000)						14.3	40900 (4620)		0.92
1.07	I	18500 (82200)				1.29	I	18300 (81600)	10	4D160	123									
1.28	I	18500 (82200)				1.52	II	18300 (81600)	10	4D165	123									
1.49	II	18500 (82200)				1.56	II	18300 (81600)	10	4D170	123									
1.56	II	18500 (82200)				1.56	II	18300 (81600)	10	4D175	123									
1.56	II	18500 (82200)				1.89	II	18300 (81600)	10	4D180	123	(-)								
1.92	II	21300 (94800)				2.01	III	21700 (96700)	10	4E175	123									
2.08	III	21300 (94800)				2.51	III	21700 (96700)	10	4E180	123	(-)								
2.08	III	21300 (94800)				2.51	III	21700 (96700)	10	4E185	123	(-)								
2.47	III	30000 (134000)				2.51	III	30400 (135000)	10	4F180	123	(-)								

# Standard Mounting Selection Tables

**10 HP  
(7.5 kW)**

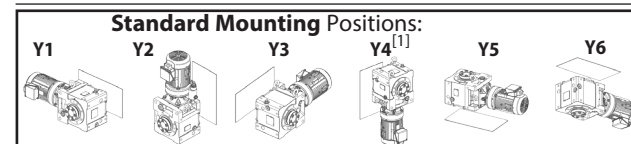

Dimension Pages:  
Single Reduction 2.132-2.143  
Single Reduction, Y2 2.144  
Double Reduction 2.146-2.161  
Double Reduction, Y2 2.162

Frequency	50 Hz	60 Hz
Input Speed	1450 RPM	1750 RPM
Number of Poles	4	

50Hz					60 Hz					Selection																				
Output Speed (RPM)	Output Torque		Service Factor		Solid Shaft Overhung Load		Output Speed (RPM)	Output Torque		Service Factor		Solid Shaft Overhung Load		Base			VFD <sup>[2]</sup>													
	in-lbs	(N·m)	SF	AGMA Class	lbs	(N)		in-lbs	(N·m)	SF	AGMA Class	lbs	(N)	Motor Power Code	Frame Size	Ratio														
9.63	60700 (6850)		0.86	-	16300 (72700)	11.6	50300 (5680)		0.99	-	18300 (81600)	10	4D160	151																
			1.04	I	16300 (72700)				1.05	I	18300 (81600)						10	4D165	151											
			1.21	I	16300 (72700)				1.27	I	18300 (81600)						10	4D170	151											
			1.27	I	16300 (72700)				1.27	I	18300 (81600)						10	4D175	151											
			1.27	I	16300 (72700)				1.54	II	18300 (81600)						10	4D180	151	(-)										
			1.51	II	20700 (92200)				1.51	II	21300 (94600)						10	4E175	151											
			1.69	II	20700 (92200)				2.01	III	21300 (94600)						10	4E180	151	(-)										
			1.69	II	20700 (92200)				2.04	III	21300 (94600)						10	4E185	151	(-)										
			2.01	III	29500 (131000)				2.01	III	30000 (133000)						10	4F180	151	(-)										
			2.48	III	29500 (131000)				2.51	III	30000 (133000)						10	4F185	151	(-)										
			2.63	III	29500 (131000)				2.79	III	30000 (133000)						10	4F190	151	(-)										
			2.63	III	29500 (131000)				3.17	III	30000 (133000)						10	4F195	151	(-)										
			8.12	72000 (8130)					0.88	-	13300 (59100)						9.80	59600 (6740)		1.00	I	16600 (73700)	10	4D165	179					
									1.02	I	13300 (59100)									1.07	I	16600 (73700)						10	4D170	179
									1.07	I	13300 (59100)									1.07	I	16600 (73700)						10	4D175	179
1.07	I	13300 (59100)				1.29	I	16600 (73700)	10	4D180	179	(-)																		
1.32	I	20200 (89700)				1.43	II	20800 (92500)	10	4E175	179																			
1.43	II	20200 (89700)				1.43	II	20800 (92500)	10	4E180	179	(-)																		
1.43	II	20200 (89700)				1.72	II	20800 (92500)	10	4E185	179	(-)																		
1.60	II	29100 (129000)				1.60	II	29600 (132000)	10	4F180	179	(-)																		
2.01	III	29100 (129000)				2.01	III	29600 (132000)	10	4F185	179	(-)																		
2.21	III	29100 (129000)				2.43	III	29600 (132000)	10	4F190	179	(-)																		
2.21	III	29100 (129000)				2.67	III	29600 (132000)	10	4F195	179	(-)																		
7.02	83200 (9400)		0.88	-	8420 (37500)	8.47	69000 (7790)		0.93	-	14200 (63200)	10	4D170	207																
			0.93	-	8420 (37500)				0.93	-	14200 (63200)						10	4D175	207											
			0.93	-	8420 (37500)				1.12	I	14200 (63200)						10	4D180	207											
			1.11	I	19600 (87100)				1.11	I	20300 (90300)						10	4E175	207											
			1.23	I	19600 (87100)				1.23	I	20300 (90300)						10	4E180	207	(-)										
			1.23	I	19600 (87100)				1.49	II	20300 (90300)						10	4E185	207	(-)										
			1.30	I	28600 (127000)				1.30	I	29200 (130000)						10	4F180	207	(-)										
			1.60	II	28600 (127000)				1.60	II	29200 (130000)						10	4F185	207	(-)										
			1.91	II	28600 (127000)				2.04	III	29200 (130000)						10	4F190	207	(-)										
			1.91	II	28600 (127000)				2.31	III	29200 (130000)						10	4F195	207	(-)										

Notes: [1] For Y4 Double Reductions (4XXXDX) refer to the above table; for Y4 single reduction refer to tables on pages 2.91-2.130.

[2] Variable Frequency Drive (VFD) notes (see page 2.8 for Constant Torque Speed Ranges):

All 1HP+ motors require EP suffix in model number and can be used with a VFD, unless noted.

(-) = For Inverter Operation, starting condition may require ambient temperature of 5° C or higher.

Notes: [1] For Y4 Double Reductions (4XXXDX) refer to the above table; for Y4 single reduction refer to tables on pages 2.91-2.130.

[2] Variable Frequency Drive (VFD) notes (see page 2.8 for Constant Torque Speed Ranges):

All 1HP+ motors require EP suffix in model number and can be used with a VFD, unless noted.

(-) = For Inverter Operation, starting condition may require ambient temperature of 5° C or higher.

# Standard Mounting Selection Tables

**10 HP  
(7.5 kW)**

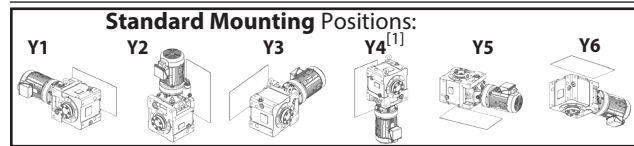

Dimension Pages:  
Single Reduction 2.132-2.143  
Single Reduction, Y2 2.144  
Double Reduction 2.146-2.161  
Double Reduction, Y2 2.162

Frequency	50 Hz	60 Hz
Input Speed	1450 RPM	1750 RPM
Number of Poles	4	

50Hz					60 Hz					Selection							
Output Speed (RPM)	Output Torque		Service Factor		Solid Shaft Overhung Load		Output Speed (RPM)	Output Torque		Service Factor		Solid Shaft Overhung Load		Base			VFD <sup>[2]</sup>
	in-lbs	(N·m)	SF	AGMA Class	lbs	(N)		in-lbs	(N·m)	SF	AGMA Class	lbs	(N)	Motor Power Code	Frame Size	Ratio	
5.84	100000 (11300)		0.93	-	18700	(83300)	7.04	83000 (9380)		0.95	-	19600	(87200)	10	<b>4E175</b>	249	
			1.02	I	18700	(83300)				1.17	I	19600	(87200)	10	<b>4E180</b>	249	(-)
			1.02	I	18700	(83300)				1.24	I	19600	(87200)	10	<b>4E185</b>	249	(-)
			1.17	I	27800	(124000)				1.17	I	28600	(127000)	10	<b>4F180</b>	249	(-)
			1.31	I	27800	(124000)				1.31	I	28600	(127000)	10	<b>4F185</b>	249	(-)
			1.59	II	27800	(124000)				1.80	II	28600	(127000)	10	<b>4F190</b>	249	(-)
			1.59	II	27800	(124000)				1.92	II	28600	(127000)	10	<b>4F195</b>	249	(-)
4.76	123000 (13900)		0.84	-	11900	(53000)	5.75	102000 (11500)		0.95	-	18700	(83000)	10	<b>4E180</b>	305	
			0.84	-	11900	(53000)				1.01	I	18700	(83000)	10	<b>4E185</b>	305	
			0.95	-	26900	(119000)				0.95	-	27800	(124000)	10	<b>4F180</b>	305	
			1.15	I	26900	(119000)				1.15	I	27800	(124000)	10	<b>4F185</b>	305	(-)
			1.30	I	26900	(119000)				1.57	II	27800	(124000)	10	<b>4F190</b>	305	(-)
3.98	139000 (15700)		1.06	I	26100	(116000)	4.81	115000 (13000)		1.28	I	27200	(121000)	10	<b>4F18DB</b>	364	(-)
			1.11	I	26100	(116000)				1.33	I	27200	(121000)	10	<b>4F19DB</b>	364	(-)
3.42	162000 (18300)		0.89	-	25200	(112000)	4.13	134000 (15200)		1.08	I	26400	(117000)	10	<b>4F18DB</b>	424	
			0.95	-	25200	(112000)				1.15	I	26400	(117000)	10	<b>4F19DB</b>	424	
2.90	191000 (21600)		0.80	-	17800	(79200)	3.50	159000 (17900)		0.97	-	25300	(113000)	10	<b>4F19DB</b>	501	

# Standard Mounting Selection Tables

**15 HP  
(11 kW)**

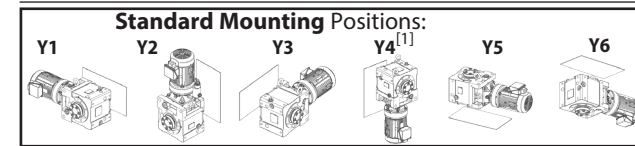

Dimension Pages:  
Single Reduction 2.132-2.143  
Single Reduction, Y2 2.144  
Double Reduction 2.146-2.161  
Double Reduction, Y2 2.162

Frequency	50 Hz	60 Hz
Input Speed	1450 RPM	1750 RPM
Number of Poles	4	

50Hz					60 Hz					Selection							
Output Speed (RPM)	Output Torque		Service Factor		Solid Shaft Overhung Load		Output Speed (RPM)	Output Torque		Service Factor		Solid Shaft Overhung Load		Base			VFD <sup>[2]</sup>
	in-lbs	(N·m)	SF	AGMA Class	lbs	(N)		in-lbs	(N·m)	SF	AGMA Class	lbs	(N)	Motor Power Code	Frame Size	Ratio	
138	6210 (701)		1.66	II	3260	(14500)	167	5140 (581)		1.84	II	3180	(14200)	15	<b>4A145</b>	11	
			2.00	III	4890	(21700)				2.00	III	4700	(20900)	15	<b>4B145</b>	11	
			2.30	III	4890	(21700)				2.30	III	4700	(20900)	15	<b>4B160</b>	11	
			2.64	III	4890	(21700)				2.64	III	4700	(20900)	15	<b>4B165</b>	11	
			2.73	III	7060	(31400)				2.73	III	6740	(30000)	15	<b>4C165</b>	11	
			113	7570 (855)		1.50				II	3310	(14700)	137	6270 (708)		1.51	II
		1.73	II	5050	(22500)	1.73	II	4870	(21700)	15	<b>4B140</b>	13					
		2.00	III	5050	(22500)	2.00	III	4870	(21700)	15	<b>4B145</b>	13					
		2.30	III	5040	(22400)	2.30	III	4860	(21600)	15	<b>4B160</b>	13					
		2.64	III	5040	(22400)	2.64	III	4860	(21600)	15	<b>4B165</b>	13					
104	8280 (935)		1.38	I	3330	(14800)	125	6860 (775)		1.38	I	3280	(14600)	15	<b>4A140</b>	14	
			1.73	II	5140	(22900)				1.73	II	4960	(22100)	15	<b>4B140</b>	14	
			2.00	III	5140	(22900)				2.00	III	4960	(22100)	15	<b>4B145</b>	14	
			2.30	III	5130	(22800)				2.30	III	4950	(22000)	15	<b>4B160</b>	14	
			2.54	III	5130	(22800)				2.64	III	4950	(22000)	15	<b>4B165</b>	14	
90.6	9460 (1070)		1.21	I	3350	(14900)	109	7840 (886)		1.21	I	3320	(14700)	15	<b>4A140</b>	16	
			1.73	II	5250	(23300)				1.73	II	5080	(22600)	15	<b>4B140</b>	16	
			2.00	III	5250	(23300)				2.00	III	5080	(22600)	15	<b>4B145</b>	16	
			2.27	III	5260	(23400)				2.30	III	5090	(22600)	15	<b>4B160</b>	16	
			2.27	III	5260	(23400)				2.40	III	5090	(22600)	15	<b>4B165</b>	16	
			2.30	III	7740	(34400)				2.30	III	7420	(33000)	15	<b>4C160</b>	16	
82.9	10300 (1170)		1.10	I	3350	(14900)	100.0	8570 (969)		1.10	I	3340	(14800)	15	<b>4A140</b>	18	
			1.73	II	5320	(23700)				1.73	II	5160	(23000)	15	<b>4B140</b>	18	
			2.00	III	5320	(23700)				2.00	III	5160	(23000)	15	<b>4B145</b>	18	
			2.15	III	5330	(23700)				2.20	III	5170	(23000)	15	<b>4B160</b>	18	
			2.30	III	7890	(35100)				2.30	III	7580	(33700)	15	<b>4C160</b>	18	
			2.73	III	7890	(35100)				2.73	III	7580	(33700)	15	<b>4C165</b>	18	
69.0	12400 (1400)		0.92	-	2160	(9600)	83.3	10300 (1160)		0.92	-	3350	(14900)	15	<b>4A140</b>	21	
			1.18	I	5460	(24300)				1.18	I	5320	(23700)	15	<b>4B140</b>	21	
			1.37	I	5460	(24300)				1.37	I	5320	(23700)	15	<b>4B145</b>	21	
			1.83	II	5460	(24300)				1.83	II	5320	(23700)	15	<b>4B160</b>	21	
			2.30	III	8170	(36300)				2.30	III	7860	(35000)	15	<b>4C160</b>	21	
			2.73	III	8170	(36300)				2.73	III	7860	(35000)	15	<b>4C165</b>	21	

Notes: [1] For Y4 Double Reductions (4XXXDX) refer to the above table; for Y4 single reduction refer to tables on pages 2.91-2.130.

[2] Variable Frequency Drive (VFD) notes (see page 2.8 for Constant Torque Speed Ranges):

All 1HP+ motors require EP suffix in model number and can be used with a VFD, unless noted.

(-) = For Inverter Operation, starting condition may require ambient temperature of 5° C or higher.

Notes: [1] For Y4 Double Reductions (4XXXDX) refer to the above table; for Y4 single reduction refer to tables on pages 2.91-2.130.

[2] Variable Frequency Drive (VFD) notes (see page 2.8 for Constant Torque Speed Ranges):

All 1HP+ motors require EP suffix in model number and can be used with a VFD, unless noted.

(-) = For Inverter Operation, starting condition may require ambient temperature of 5° C or higher.



# Standard Mounting Selection Tables

**15 HP**  
(11 kW)

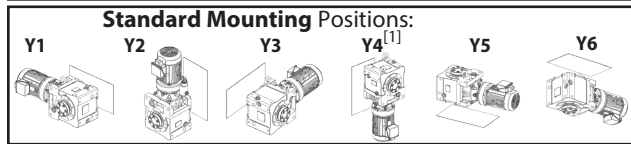

Dimension Pages:  
Single Reduction, Y2 2.132-2.143  
Single Reduction, Y2 2.144  
Double Reduction 2.146-2.161  
Double Reduction, Y2 2.162

Frequency	50 Hz	60 Hz
Input Speed	1450 RPM	1750 RPM
Number of Poles	4	

50Hz					60 Hz					Selection									
Output Speed (RPM)	Output Torque		Service Factor		Solid Shaft Overhung Load		Output Speed (RPM)	Output Torque		Service Factor		Solid Shaft Overhung Load		Base			VFD <sup>[2]</sup>		
	in-lbs	(N·m)	SF	AGMA Class	lbs	(N)		in-lbs	(N·m)	SF	AGMA Class	lbs	(N)	Motor Power Code	Frame Size	Ratio			
64.7	13200 (1500)		0.86	-	290 (1290)	78.1	11000 (1240)		0.86	-	3350 (14900)	15	4A140	22					
			1.18	I	5500 (24500)				1.18	I	5370 (23900)						4B140		
			1.37	I	5500 (24500)				1.37	I	5370 (23900)						4B145		
			1.72	II	5500 (24500)				1.72	II	5370 (23900)						4B160		
			1.85	II	8270 (36800)				1.85	II	7970 (35400)						4C160		
			2.19	III	8270 (36800)				2.19	III	7970 (35400)						4C165		
59.2	14500 (1640)		1.18	I	5560 (24700)	71.4	12000 (1360)		1.18	I	5440 (24200)	15	4B140	25					
			1.37	I	5560 (24700)				1.37	I	5440 (24200)						4B145		
			1.57	II	5560 (24700)				1.57	II	5440 (24200)						4B160		
			1.85	II	8420 (37400)				1.85	II	8110 (36100)						4C160		
			2.19	III	8420 (37400)				2.19	III	8110 (36100)						4C165		
			2.94	III	8420 (37400)				3.14	III	8110 (36100)						4C175		
51.8	16600 (1870)		1.18	I	5630 (25000)	62.5	13700 (1550)		1.18	I	5530 (24600)	15	4B140	28					
			1.37	I	5630 (25000)				1.37	I	5530 (24600)						4B145		
			1.79	II	8620 (38300)				1.79	II	8330 (37100)						4C160		
			2.19	III	8620 (38300)				2.19	III	8330 (37100)						4C165		
			2.67	III	8620 (38300)				2.75	III	8330 (37100)						4C170		
			2.67	III	8620 (38300)				2.75	III	8330 (37100)						4C170		
41.2	20800 (2350)		1.09	I	5690 (25300)	49.7	17200 (1950)		1.09	I	5640 (25100)	15	4B140	35					
			1.18	I	8940 (39800)				1.18	I	8680 (38600)						4C140		
			1.37	I	8940 (39800)				1.37	I	8680 (38600)						4C145		
			1.79	II	8940 (39800)				1.79	II	8680 (38600)						4C160		
			2.19	III	14100 (62600)				2.19	III	13500 (60000)						4D165		
			2.51	III	14100 (62600)				2.51	III	13500 (60000)						4D170		
2.74	III	14100 (62600)	2.74	III	13500 (60000)	4D175													
37.7	22800 (2570)		1.00	I	5700 (25400)	45.5	18900 (2130)		1.00	I	5670 (25200)	15	4B140	39					
			1.18	I	9050 (40300)				1.18	I	8810 (39200)						4C140		
			1.37	I	9050 (40300)				1.37	I	8810 (39200)						4C145		
			1.79	II	9050 (40300)				1.79	II	8810 (39200)						4C160		
			1.95	II	9050 (40300)				2.00	III	8810 (39200)						4C165		
			2.19	III	14300 (63800)				2.19	III	13800 (61300)						4D165		
			2.51	III	14300 (63800)				2.51	III	13800 (61300)						4D170		
			2.74	III	14300 (63800)				2.74	III	13800 (61300)						4D175		
			1.00	I	5700 (25400)				1.00	I	5670 (25200)						15	4B140	39
			1.18	I	9050 (40300)				1.18	I	8810 (39200)						15	4C140	39
			1.37	I	9050 (40300)				1.37	I	8810 (39200)						15	4C145	39
1.79	II	9050 (40300)	1.79	II	8810 (39200)	15	4C160	39											
1.95	II	9050 (40300)	2.00	III	8810 (39200)	15	4C165	39											
2.19	III	14300 (63800)	2.19	III	13800 (61300)	15	4D165	39											
2.51	III	14300 (63800)	2.51	III	13800 (61300)	15	4D170	39											
2.74	III	14300 (63800)	2.74	III	13800 (61300)	15	4D175	39											

# Standard Mounting Selection Tables

**15 HP**  
(11 kW)

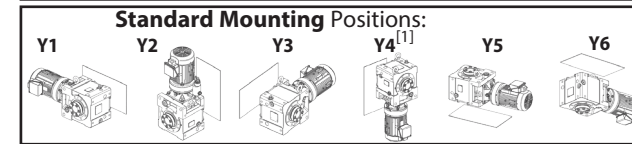

Dimension Pages:  
Single Reduction, Y2 2.132-2.143  
Single Reduction, Y2 2.144  
Double Reduction 2.146-2.161  
Double Reduction, Y2 2.162

Frequency	50 Hz	60 Hz
Input Speed	1450 RPM	1750 RPM
Number of Poles	4	

50Hz					60 Hz					Selection							
Output Speed (RPM)	Output Torque		Service Factor		Solid Shaft Overhung Load		Output Speed (RPM)	Output Torque		Service Factor		Solid Shaft Overhung Load		Base			VFD <sup>[2]</sup>
	in-lbs	(N·m)	SF	AGMA Class	lbs	(N)		in-lbs	(N·m)	SF	AGMA Class	lbs	(N)	Motor Power Code	Frame Size	Ratio	
31.9	26900 (3040)		0.85	-	2350 (10500)	38.5	22300 (2520)		0.85	-	5700 (25400)	15	4B140	46			
			1.18	I	9240 (41100)				1.18	I	9030 (40200)						4C140
			1.37	I	9240 (41100)				1.37	I	9030 (40200)						4C145
			1.65	II	9240 (41100)				1.69	II	9030 (40200)						4C160
			1.79	II	14800 (66000)				1.79	II	14300 (63500)						4D160
			2.05	III	14800 (66000)				2.05	III	14300 (63500)						4D165
			2.48	III	14800 (66000)				2.48	III	14300 (63500)						4D170
			2.74	III	14800 (66000)				2.74	III	14300 (63500)						4D175
			2.87	III	14800 (66000)				3.38	III	14300 (63500)						4D180
			2.87	III	14800 (66000)				3.38	III	14300 (63500)						4D180
			27.6	31000 (3510)					1.09	I	9360 (41600)						33.3
1.32	I	9360 (41600)				1.33	I	9190 (40900)	4C145								
1.43	II	9360 (41600)				1.47	II	9190 (40900)	4C160								
1.70	II	15300 (67900)				1.70	II	14700 (65500)	4D160								
2.03	III	15300 (67900)				2.05	III	14700 (65500)	4D165								
2.32	III	15300 (67900)				2.32	III	14700 (65500)	4D170								
2.49	III	15300 (67900)				2.49	III	14700 (65500)	4D175								
2.49	III	15300 (67900)				2.95	III	14700 (65500)	4D180								
2.73	III	20500 (91200)				2.74	III	19700 (87400)	4E175								
2.80	III	20500 (91200)				2.95	III	19700 (87400)	4E180								
2.95	III	30800 (137000)				3.38	III	19700 (87400)	4E185								
2.95	III	30800 (137000)	2.95	III	31100 (138000)	4F180											
24.4	35200 (3970)		1.09	I	9440 (42000)	29.4	29100 (3290)		1.09	I	9310 (41400)	15	4C145	60			
			1.19	I	9440 (42000)				1.19	I	9310 (41400)						4C160
			1.26	I	9440 (42000)				1.29	I	9310 (41400)						4C165
			1.71	II	15600 (69400)				1.71	II	15100 (67100)						4D165
			1.79	II	15600 (69400)				1.79	II	15100 (67100)						4D170
			2.19	III	15600 (69400)				2.19	III	15100 (67100)						4D175
			2.19	III	15600 (69400)				2.65	III	15100 (67100)						4D180
			2.47	III	21100 (93800)				2.78	III	20200 (90000)						4E180
			2.47	III	21100 (93800)				2.99	III	20200 (90000)						4E185
			2.47	III	21100 (93800)				2.99	III	20200 (90000)						4E190
			2.47	III	21100 (93800)				2.99	III	20200 (90000)						4E195
2.78	III	30600 (136000)	2.78	III	30900 (137000)	4F180											

Notes: [1] For Y4 Double Reductions (4XXXDX) refer to the above table; for Y4 single reduction refer to tables on pages 2.91-2.130.

[2] Variable Frequency Drive (VFD) notes (see page 2.8 for Constant Torque Speed Ranges):

All 1HP+ motors require EP suffix in model number and can be used with a VFD, unless noted.

Notes: [1] For Y4 Double Reductions (4XXXDX) refer to the above table; for Y4 single reduction refer to tables on pages 2.91-2.130.

[2] Variable Frequency Drive (VFD) notes (see page 2.8 for Constant Torque Speed Ranges):

All 1HP+ motors require EP suffix in model number and can be used with a VFD, unless noted.

(-) = For Inverter Operation, starting condition may require ambient temperature of 5° C or higher.

# Standard Mounting Selection Tables

**15 HP  
(11 kW)**

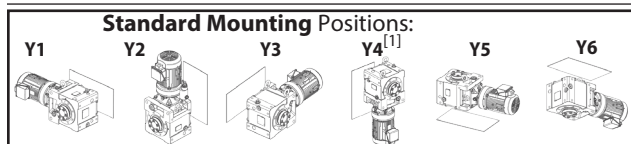

Dimension Pages:  
Single Reduction 2.132-2.143  
Single Reduction, Y2 2.144  
Double Reduction 2.146-2.161  
Double Reduction, Y2 2.162

Frequency	50 Hz	60 Hz
Input Speed	1450 RPM	1750 RPM
Number of Poles	4	

50Hz					60 Hz					Selection							
Output Speed (RPM)	Output Torque		Service Factor		Solid Shaft Overhung Load		Output Speed (RPM)	Output Torque		Service Factor		Solid Shaft Overhung Load		Base			VFD <sup>[2]</sup>
	in-lbs	(N·m)	SF	AGMA Class	lbs	(N)		in-lbs	(N·m)	SF	AGMA Class	lbs	(N)	Motor Power Code	Frame Size	Ratio	
21.6	39700 (4490)		1.15	I	9480 (42200)	26.0	32900 (3720)	1.15	I	9400 (41800)	15	<b>4C160</b>	67				
			1.45	II	15900 (70800)			1.46	II	15400 (68600)	15	<b>4D165</b>	67				
			1.69	II	15900 (70800)			1.77	II	15400 (68600)	15	<b>4D170</b>	67				
			1.94	II	15900 (70800)			1.94	II	15400 (68600)	15	<b>4D175</b>	67				
			1.94	II	15900 (70800)			2.34	III	15400 (68600)	15	<b>4D180</b>	67		(-)		
			2.14	III	21600 (96200)			2.19	III	20800 (92400)	15	<b>4E175</b>	67		(-)		
			2.19	III	21600 (96200)			2.64	III	20800 (92400)	15	<b>4E180</b>	67				
			2.19	III	21600 (96200)			2.64	III	20800 (92400)	15	<b>4E185</b>	67		(-)		
			2.19	III	21600 (96200)			2.64	III	20800 (92400)	15	<b>4E190</b>	67				
			2.19	III	21600 (96200)			2.64	III	20800 (92400)	15	<b>4E195</b>	67		(-)		
2.73	III	30500 (135000)	2.73	III	30700 (137000)	15	<b>4F180</b>	67									
19.7	43500 (4910)		0.86	-	9490 (42200)	23.8	36000 (4070)	1.00	I	9450 (42000)	15	<b>4C145</b>	74				
			1.02	I	9490 (42200)			1.05	I	9450 (42000)	15	<b>4C160</b>	74				
			1.17	I	16100 (71800)			1.17	I	15700 (69700)	15	<b>4D160</b>	74				
			1.45	II	16100 (71800)			1.46	II	15700 (69700)	15	<b>4D165</b>	74				
			1.69	II	16100 (71800)			1.77	II	15700 (69700)	15	<b>4D170</b>	74				
			1.78	II	16100 (71800)			1.78	II	15700 (69700)	15	<b>4D175</b>	74				
			1.78	II	16100 (71800)			2.14	III	15700 (69700)	15	<b>4D180</b>	74		(-)		
			2.00	III	21600 (96100)			2.00	III	21200 (94200)	15	<b>4E175</b>	74		(-)		
			2.00	III	21600 (96100)			2.42	III	21200 (94200)	15	<b>4E180</b>	74				
			2.00	III	21600 (96100)			2.42	III	21200 (94200)	15	<b>4E185</b>	74		(-)		
			2.00	III	21600 (96100)			2.42	III	21200 (94200)	15	<b>4E190</b>	74				
			2.00	III	21600 (96100)			2.42	III	21200 (94200)	15	<b>4E195</b>	74		(-)		
			2.73	III	30300 (135000)			2.73	III	30600 (136000)	15	<b>4F180</b>	74				
			18.1	47300 (5340)				0.96	-	8660 (38500)	21.9	39200 (4430)	0.96		-	9480 (42200)	15
1.22	I	16300 (72700)				1.37	I	15900 (70700)	15	<b>4D165</b>			80				
1.42	II	16300 (72700)				1.44	II	15900 (70700)	15	<b>4D170</b>			80				
1.63	II	16300 (72700)				1.63	II	15900 (70700)	15	<b>4D175</b>			80				
1.63	II	16300 (72700)				1.97	II	15900 (70700)	15	<b>4D180</b>			80	(-)			
1.77	II	21400 (95200)				1.77	II	21600 (95900)	15	<b>4E175</b>			80	(-)			
1.84	II	21400 (95200)				2.19	III	21600 (95900)	15	<b>4E180</b>			80				
1.84	II	21400 (95200)				2.22	III	21600 (95900)	15	<b>4E185</b>			80	(-)			
1.84	II	21400 (95200)				2.22	III	21600 (95900)	15	<b>4E190</b>			80				
1.84	II	21400 (95200)				2.22	III	21600 (95900)	15	<b>4E195</b>			80	(-)			
2.19	III	30100 (134000)				2.19	III	30500 (136000)	15	<b>4F180</b>			80				
2.74	III	30100 (134000)				2.74	III	30500 (136000)	15	<b>4F185</b>			80	(-)			

# Standard Mounting Selection Tables

**15 HP  
(11 kW)**

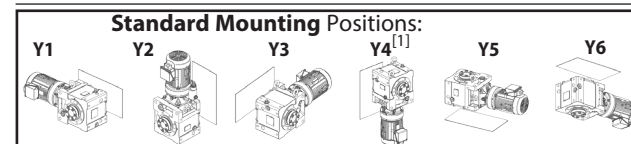

Dimension Pages:  
Single Reduction 2.132-2.143  
Single Reduction, Y2 2.144  
Double Reduction 2.146-2.161  
Double Reduction, Y2 2.162

Frequency	50 Hz	60 Hz
Input Speed	1450 RPM	1750 RPM
Number of Poles	4	

50Hz					60 Hz					Selection										
Output Speed (RPM)	Output Torque		Service Factor		Solid Shaft Overhung Load		Output Speed (RPM)	Output Torque		Service Factor		Solid Shaft Overhung Load		Base			VFD <sup>[2]</sup>			
	in-lbs	(N·m)	SF	AGMA Class	lbs	(N)		in-lbs	(N·m)	SF	AGMA Class	lbs	(N)	Motor Power Code	Frame Size	Ratio				
16.6	51700 (5840)		0.86	-	6210 (27600)	20.0	42900 (4840)	0.88	-	9490 (42200)	15	<b>4C160</b>	88							
			1.22	I	16500 (73600)			1.37	I	16100 (71700)	15	<b>4D165</b>	88							
			1.42	II	16500 (73600)			1.44	II	16100 (71700)	15	<b>4D170</b>	88							
			1.49	II	16500 (73600)			1.49	II	16100 (71700)	15	<b>4D175</b>	88							
			1.49	II	16500 (73600)			1.80	II	16100 (71700)	15	<b>4D180</b>	88							
			1.68	II	21200 (94200)			1.68	II	21600 (96200)	15	<b>4E175</b>	88		(-)					
			1.68	II	21200 (94200)			2.03	III	21600 (96200)	15	<b>4E180</b>	88							
			1.68	II	21200 (94200)			2.03	III	21600 (96200)	15	<b>4E185</b>	88		(-)					
			1.68	II	21200 (94200)			2.03	III	21600 (96200)	15	<b>4E190</b>	88							
			1.68	II	21200 (94200)			2.03	III	21600 (96200)	15	<b>4E195</b>	88		(-)					
			2.19	III	29900 (133000)			2.19	III	30300 (135000)	15	<b>4F180</b>	88							
			2.74	III	29900 (133000)			2.74	III	30300 (135000)	15	<b>4F185</b>	88		(-)					
			14.3	60000 (6780)				1.04	I	16500 (73300)	17.2	49700 (5620)	1.04			I	16500 (73300)	15	<b>4D165</b>	102
								1.22	I	16500 (73300)			1.29		I	16500 (73300)	15	<b>4D170</b>	102	
1.29	I	16500 (73300)				1.29	I	16500 (73300)	15	<b>4D175</b>			102							
1.29	I	16500 (73300)				1.55	II	16500 (73300)	15	<b>4D180</b>			102							
1.45	II	20800 (92400)				1.45	II	21300 (94700)	15	<b>4E175</b>			102							
1.45	II	20800 (92400)				1.75	II	21300 (94700)	15	<b>4E180</b>			102							
1.45	II	20800 (92400)				1.75	II	21300 (94700)	15	<b>4E185</b>			102							
1.45	II	20800 (92400)				1.75	II	21300 (94700)	15	<b>4E190</b>			102	(-)						
1.45	II	20800 (92400)				1.75	II	21300 (94700)	15	<b>4E195</b>			102	(-)						
1.77	II	29600 (132000)				1.77	II	30000 (134000)	15	<b>4F180</b>			102	(-)						
2.19	III	29600 (132000)				2.19	III	30000 (134000)	15	<b>4F185</b>			102							
2.65	III	29600 (132000)				2.65	III	29600 (132000)	15	<b>4F190</b>			102	(-)						
2.65	III	29600 (132000)				3.20	III	30000 (134000)	15	<b>4F195</b>			102							
12.9	66200 (7480)					0.87	-	15000 (66600)	15.6	54900 (6200)			1.04	I	16600 (74100)	15	<b>4D165</b>	112		
			1.01	I	15000 (66600)	1.09	I	16600 (74100)			15	<b>4D170</b>	112							
			1.17	I	15000 (66600)	1.17	I	16600 (74100)			15	<b>4D175</b>	112							
			1.17	I	15000 (66600)	1.41	II	16600 (74100)			15	<b>4D180</b>	112							
			1.31	I	20400 (91000)	1.37	I	21000 (93500)			15	<b>4E175</b>	112							
			1.55	II	20400 (91000)	1.71	II	21000 (93500)			15	<b>4E180</b>	112							
			1.55	II	20400 (91000)	1.87	II	21000 (93500)			15	<b>4E185</b>	112							
			1.68	II	29300 (130000)	1.71	II	29800 (133000)			15	<b>4F180</b>	112							
			2.05	III	29300 (130000)	2.05	III	29800 (133000)			15	<b>4F185</b>	112							
			2.21	III	29300 (130000)	2.21	III	29800 (133000)			15	<b>4F190</b>	112	(-)						
			2.41	III	29300 (130000)	2.74	III	29800 (133000)			15	<b>4F195</b>	112	(-)						

Notes: [1] For Y4 Double Reductions (4XXXDX) refer to the above table; for Y4 single reduction refer to tables on pages 2.91-2.130.

[2] Variable Frequency Drive (VFD) notes (see page 2.8 for Constant Torque Speed Ranges):

All 1HP+ motors require EP suffix in model number and can be used with a VFD, unless noted.

(-) = For Inverter Operation, starting condition may require ambient temperature of 5° C or higher.

Notes: [1] For Y4 Double Reductions (4XXXDX) refer to the above table; for Y4 single reduction refer to tables on pages 2.91-2.130.

[2] Variable Frequency Drive (VFD) notes (see page 2.8 for Constant Torque Speed Ranges):

All 1HP+ motors require EP suffix in model number and can be used with a VFD, unless noted.

(-) = For Inverter Operation, starting condition may require ambient temperature of 5° C or higher.

# Standard Mounting Selection Tables

**15 HP**  
(11 kW)

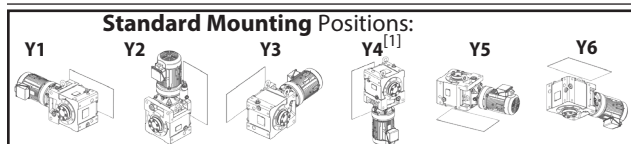

Dimension Pages:  
Single Reduction 2.132-2.143  
Single Reduction, Y2 2.144  
Double Reduction 2.146-2.161  
Double Reduction, Y2 2.162

Frequency	50 Hz	60 Hz
Input Speed	1450 RPM	1750 RPM
Number of Poles	4	

50Hz				60 Hz				Selection							
Output Speed (RPM)	Output Torque		Service Factor	Solid Shaft Overhung Load		Output Speed (RPM)	Output Torque		Service Factor	Solid Shaft Overhung Load		Base			VFD <sup>[2]</sup>
	in-lbs	(N·m)		lbs	(N)		in-lbs	(N·m)		lbs	(N)	Motor Power Code	Frame Size	Ratio	
11.8	72400 (8180)		0.87	-	13100 (58400)	14.3	60000 (6780)	1.04	I	16500 (73300)	15	<b>4D165</b>	123		
			1.01	I	13100 (58400)	1.07	I	16500 (73300)	15	<b>4D170</b>	123				
			1.07	I	13100 (58400)	1.07	I	16500 (73300)	15	<b>4D175</b>	123				
			1.07	I	13100 (58400)	1.29	I	16500 (73300)	15	<b>4D180</b>	123				
			1.31	I	20100 (89600)	1.37	I	20800 (92400)	15	<b>4E175</b>	123				
			1.42	II	20100 (89600)	1.71	II	20800 (92400)	15	<b>4E180</b>	123				
			1.42	II	20100 (89600)	1.71	II	20800 (92400)	15	<b>4E185</b>	123				
			1.68	II	29000 (129000)	1.71	II	29600 (132000)	15	<b>4F180</b>	123				
			2.05	III	29000 (129000)	2.05	III	29600 (132000)	15	<b>4F185</b>	123				
			2.20	III	29000 (129000)	2.21	III	29600 (132000)	15	<b>4F190</b>	123	(-)			
2.20	III	29000 (129000)	2.65	III	29600 (132000)	15	<b>4F195</b>	123	(-)						
9.63	89000 (10100)		0.87	-	3350 (14900)	11.6	73700 (8330)	0.87	-	12700 (56400)	15	<b>4D175</b>	151		
			0.87	-	3350 (14900)	1.05	I	12700 (56400)	15	<b>4D180</b>	151				
			1.03	I	19300 (85800)	1.03	I	20100 (89300)	15	<b>4E175</b>	151				
			1.15	I	19300 (85800)	1.37	I	20100 (89300)	15	<b>4E180</b>	151				
			1.15	I	19300 (85800)	1.39	I	20100 (89300)	15	<b>4E185</b>	151				
			1.37	I	28300 (126000)	1.37	I	29000 (129000)	15	<b>4F180</b>	151				
			1.69	II	28300 (126000)	1.71	II	29000 (129000)	15	<b>4F185</b>	151				
			1.79	II	28300 (126000)	1.90	II	29000 (129000)	15	<b>4F190</b>	151	(-)			
			1.79	II	28300 (126000)	2.16	III	29000 (129000)	15	<b>4F195</b>	151	(-)			
			8.12	106000 (11900)		0.90	-	17700 (78800)	9.80	87400 (9880)	0.97	-	19400 (86200)	15	<b>4E175</b>
0.97	-	17700 (78800)				1.09	I	19400 (86200)	15	<b>4E180</b>	179				
0.97	-	17700 (78800)				1.17	I	19400 (86200)	15	<b>4E185</b>	179				
1.09	I	27600 (123000)				1.09	I	28400 (126000)	15	<b>4F180</b>	179				
1.37	I	27600 (123000)				1.37	I	28400 (126000)	15	<b>4F185</b>	179				
1.51	II	27600 (123000)				1.65	II	28400 (126000)	15	<b>4F190</b>	179				
1.51	II	27600 (123000)				1.82	II	28400 (126000)	15	<b>4F195</b>	179				
7.02	122000 (13800)		0.84	-	12200 (54300)	8.47	101000 (11400)	0.89	-	18700 (83100)	15	<b>4E180</b>	207		
			0.84	-	12200 (54300)	1.01	I	18700 (83100)	15	<b>4E185</b>	207				
			0.89	-	26900 (120000)	0.89	-	27800 (124000)	15	<b>4F180</b>	207				
			1.09	I	26900 (120000)	1.09	I	27800 (124000)	15	<b>4F185</b>	207				
			1.30	I	26900 (120000)	1.39	I	27800 (124000)	15	<b>4F190</b>	207				
			1.30	I	26900 (120000)	1.57	II	27800 (124000)	15	<b>4F195</b>	207				
5.84	147000 (16600)		0.89	-	25800 (115000)	7.04	122000 (13800)	0.89	-	26900 (120000)	15	<b>4F185</b>	249		
			1.08	I	25800 (115000)	1.23	I	26900 (120000)	15	<b>4F190</b>	249				
			1.08	I	25800 (115000)	1.31	I	26900 (120000)	15	<b>4F195</b>	249				
4.76	180000 (20300)	0.88	-	24400 (108000)	5.75	149000 (16900)	1.07	I	25700 (114000)	15	<b>4F190</b>	305			

Notes: [1] For Y4 Double Reductions (4XXXDX) refer to the above table; for Y4 single reduction refer to tables on pages 2.91-2.130.

[2] Variable Frequency Drive (VFD) notes (see page 2.8 for Constant Torque Speed Ranges):

All 1HP+ motors require EP suffix in model number and can be used with a VFD, unless noted.

(-) = For Inverter Operation, starting condition may require ambient temperature of 5° C or higher.

# Standard Mounting Selection Tables

**20 HP**  
(15 kW)

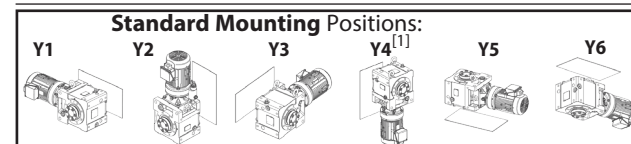

Dimension Pages:  
Single Reduction 2.132-2.143  
Single Reduction, Y2 2.144  
Double Reduction 2.146-2.161  
Double Reduction, Y2 2.162

Frequency	50 Hz	60 Hz
Input Speed	1450 RPM	1750 RPM
Number of Poles	4	

50Hz				60 Hz				Selection							
Output Speed (RPM)	Output Torque		Service Factor	Solid Shaft Overhung Load		Output Speed (RPM)	Output Torque		Service Factor	Solid Shaft Overhung Load		Base			VFD <sup>[2]</sup>
	in-lbs	(N·m)		lbs	(N)		in-lbs	(N·m)		lbs	(N)	Motor Power Code	Frame Size	Ratio	
138	8470 (956)		1.22	I	2940 (13100)	167	7010 (792)	1.35	I	2920 (13000)	20	<b>4A145</b>	11		
			1.47	II	4640 (20600)	1.47	II	4490 (20000)	20	<b>4B145</b>	11				
			1.69	II	4630 (20600)	1.69	II	4490 (20000)	20	<b>4B160</b>	11				
			1.93	II	4630 (20600)	1.93	II	4490 (20000)	20	<b>4B165</b>	11				
			2.00	III	6840 (30400)	2.00	III	6560 (29200)	20	<b>4C165</b>	11				
			2.77	III	6840 (30400)	2.77	III	6560 (29200)	20	<b>4C170</b>	11	(#)			
			2.77	III	10400 (46100)	2.77	III	9880 (43900)	20	<b>4D170</b>	11	(#)			
113	10300 (1170)		1.10	I	2930 (13000)	137	8550 (966)	1.11	I	2930 (13100)	20	<b>4A140</b>	13		
			1.27	I	4750 (21100)	1.27	I	4620 (20600)	20	<b>4B140</b>	13				
			1.47	II	4750 (21100)	1.47	II	4620 (20600)	20	<b>4B145</b>	13				
			1.69	II	4750 (21100)	1.69	II	4620 (20500)	20	<b>4B160</b>	13				
			1.93	II	4750 (21100)	1.93	II	4620 (20500)	20	<b>4B165</b>	13				
			2.00	III	7080 (31500)	2.00	III	6800 (30300)	20	<b>4C165</b>	13				
			2.77	III	7110 (31600)	2.77	III	6840 (30400)	20	<b>4C170</b>	13	(#)			
2.77	III	10900 (48300)	2.77	III	10400 (46100)	20	<b>4D170</b>	13	(#)						
104	11300 (1280)		1.01	I	2910 (13000)	125	9350 (1060)	1.01	I	2940 (13100)	20	<b>4A140</b>	14		
			1.27	I	4810 (21400)	1.27	I	4690 (20900)	20	<b>4B140</b>	14				
			1.47	II	4810 (21400)	1.47	II	4690 (20900)	20	<b>4B145</b>	14				
			1.69	II	4800 (21400)	1.69	II	4680 (20800)	20	<b>4B160</b>	14				
			1.86	II	4800 (21400)	1.93	II	4680 (20800)	20	<b>4B165</b>	14				
			2.00	III	7210 (32100)	2.00	III	6940 (30900)	20	<b>4C165</b>	14				
			2.77	III	7240 (32200)	2.77	III	6970 (31000)	20	<b>4C170</b>	14	(#)			
2.77	III	11100 (49400)	2.77	III	10600 (47100)	20	<b>4D170</b>	14	(#)						
90.6	12900 (1460)		1.27	I	4870 (21700)	109	10700 (1210)	1.27	I	4770 (21200)	20	<b>4B140</b>	16		
			1.47	II	4870 (21700)	1.47	II	4770 (21200)	20	<b>4B145</b>	16				
			1.67	II	4880 (21700)	1.76	II	4780 (21300)	20	<b>4B165</b>	16				
			2.00	III	7410 (33000)	2.00	III	7150 (31800)	20	<b>4C165</b>	16				
			2.77	III	7400 (32900)	2.77	III	7140 (31800)	20	<b>4C170</b>	16	(#)			
			2.95	III	7400 (32900)	3.00	III	7140 (31800)	20	<b>4C175</b>	16	(#)			
2.77	III	11400 (50800)	2.77	III	10900 (48600)	20	<b>4D170</b>	16	(#)						
82.9	14100 (1590)		1.27	I	4920 (21900)	100.0	11700 (1320)	1.27	I	4820 (21500)	20	<b>4B140</b>	18		
			1.47	II	4920 (21900)	1.47	II	4820 (21500)	20	<b>4B145</b>	18				
			1.58	II	4920 (21900)	1.61	II	4830 (21500)	20	<b>4B160</b>	18				
			1.69	II	7530 (33500)	1.69	II	7280 (32400)	20	<b>4C160</b>	18				
			2.00	III	7530 (33500)	2.00	III	7280 (32400)	20	<b>4C165</b>	18				
			2.76	III	7530 (33500)	2.77	III	7270 (32300)	20	<b>4C170</b>	18	(#)			
			2.76	III	7530 (33500)	3.00	III	7270 (32300)	20	<b>4C175</b>	18	(#)			
			2.77	III	11700 (51900)	2.77	III	11200 (49600)	20	<b>4D170</b>	18	(#)			

Notes: [1] For Y4 Double Reductions (4XXXDX) refer to the above table; for Y4 single reduction refer to tables on pages 2.91-2.130.

[2] Variable Frequency Drive (VFD) notes (see page 2.8 for Constant Torque Speed Ranges):

All 1HP+ motors require EP suffix in model number and can be used with a VFD, unless noted.

(#) = Mounting positions Y2, F2, G2, K2, V2, W2 operation is limited to 75 %ED (duty cycle) for a 10 minute total cycle (7.5 minutes max. on time).

# Standard Mounting Selection Tables

**20 HP  
(15 kW)**

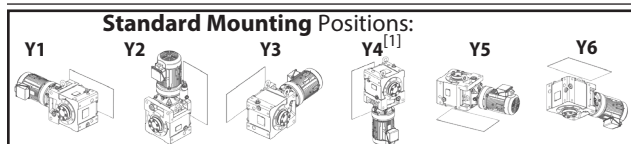

Dimension Pages:  
Single Reduction 2.132-2.143  
Single Reduction, Y2 2.144  
Double Reduction 2.146-2.161  
Double Reduction, Y2 2.162

Frequency	50 Hz	60 Hz
Input Speed	1450 RPM	1750 RPM
Number of Poles	4	

50Hz					60 Hz					Selection							
Output Speed (RPM)	Output Torque		Service Factor		Solid Shaft Overhung Load		Output Speed (RPM)	Output Torque		Service Factor		Solid Shaft Overhung Load		Base			VFD <sup>[2]</sup>
	in-lbs	(N·m)	SF	AGMA Class	lbs	(N)		in-lbs	(N·m)	SF	AGMA Class	lbs	(N)	Motor Power Code	Frame Size	Ratio	
69.0	16900 (1910)		1.01	I	4970 (22100)	83.3	14000 (1580)	1.01	I	4910 (21900)	20	<b>4B145</b>	21				
			1.34	I	4970 (22100)			1.34	I	4910 (21900)	20	<b>4B160</b>	21				
			1.69	II	7740 (34400)			1.69	II	7500 (33400)	20	<b>4C160</b>	21				
			2.00	III	7740 (34400)			2.00	III	7500 (33400)	20	<b>4C165</b>	21				
			2.26	III	7740 (34400)			2.26	III	7500 (33400)	20	<b>4C170</b>	21				
			2.40	III	7740 (34400)			2.40	III	7500 (33400)	20	<b>4C175</b>	21				
			2.77	III	12100 (53900)			2.77	III	11600 (51700)	20	<b>4D180</b>	21				(-),(#)
64.7	18100 (2040)		1.01	I	4980 (22200)	78.1	15000 (1690)	1.01	I	4940 (22000)	20	<b>4B145</b>	22				
			1.26	I	4980 (22200)			1.26	I	4940 (22000)	20	<b>4B160</b>	22				
			1.35	I	7820 (34800)			1.35	I	7590 (33700)	20	<b>4C160</b>	22				
			2.26	III	7820 (34800)			2.26	III	7590 (33700)	20	<b>4C170</b>	22				
			2.34	III	7820 (34800)			2.40	III	7590 (33700)	20	<b>4C175</b>	22				
			2.47	III	12300 (54700)			2.47	III	11800 (52500)	20	<b>4D175</b>	22				
			2.77	III	12300 (54700)			2.77	III	11800 (52500)	20	<b>4D180</b>	22				(-),(#)
59.2	19800 (2230)		1.01	I	4990 (22200)	71.4	16400 (1850)	1.01	I	4970 (22100)	20	<b>4B145</b>	25				
			1.15	I	4990 (22200)			1.15	I	4970 (22100)	20	<b>4B160</b>	25				
			1.35	I	7920 (35200)			1.35	I	7700 (34300)	20	<b>4C160</b>	25				
			1.61	II	7920 (35200)			1.61	II	7700 (34300)	20	<b>4C165</b>	25				
			2.15	III	7920 (35200)			2.30	III	7700 (34300)	20	<b>4C175</b>	25				
			2.26	III	12500 (55800)			2.26	III	12000 (53500)	20	<b>4D170</b>	25				
			2.47	III	12500 (55800)			2.47	III	12000 (53500)	20	<b>4D175</b>	25				
2.77	III	12500 (55800)	2.77	III	12000 (53500)	20	<b>4D180</b>	25	(-),(#)								
51.8	22600 (2550)		1.01	I	4980 (22100)	62.5	18700 (2110)	1.01	I	4990 (22200)	20	<b>4B145</b>	28				
			1.31	I	8050 (35800)			1.31	I	7860 (35000)	20	<b>4C160</b>	28				
			1.61	II	8050 (35800)			1.61	II	7860 (35000)	20	<b>4C165</b>	28				
			1.96	II	8050 (35800)			2.02	III	7860 (35000)	20	<b>4C170</b>	28				
			2.26	III	12900 (57300)			2.26	III	12400 (55100)	20	<b>4D170</b>	28				
			2.47	III	12900 (57300)			2.47	III	12400 (55100)	20	<b>4D175</b>	28				
			2.77	III	12900 (57300)			2.77	III	12400 (55100)	20	<b>4D180</b>	28				(-),(#)
41.2	28400 (3210)		1.01	I	8220 (36600)	49.7	23500 (2660)	1.01	I	8080 (36000)	20	<b>4C145</b>	35				
			1.31	I	8220 (36600)			1.31	I	8080 (36000)	20	<b>4C160</b>	35				
			1.60	II	8220 (36600)			1.60	II	8080 (36000)	20	<b>4C165</b>	35				
			1.84	II	13500 (59900)			1.84	II	13000 (57800)	20	<b>4D170</b>	35				
			2.01	III	13500 (59900)			2.01	III	13000 (57800)	20	<b>4D175</b>	35				
			2.65	III	13500 (59900)			2.77	III	13000 (57800)	20	<b>4D180</b>	35				(-),(#)
			2.77	III	18100 (80700)			2.77	III	17400 (77300)	20	<b>4E180</b>	35				(-),(#)

Notes: [1] For Y4 Double Reductions (4XXXDX) refer to the above table; for Y4 single reduction refer to tables on pages 2.91-2.130.

[2] Variable Frequency Drive (VFD) notes (see page 2.8 for Constant Torque Speed Ranges):

All 1HP+ motors require EP suffix in model number and can be used with a VFD, unless noted.

(-) = For Inverter Operation, starting condition may require ambient temperature of 5° C or higher.

(#) = Mounting positions Y2, F2, G2, K2, V2, W2 operation is limited to 75 %ED (duty cycle) for a 10 minute total cycle (7.5 minutes max. on time).

# Standard Mounting Selection Tables

**20 HP  
(15 kW)**

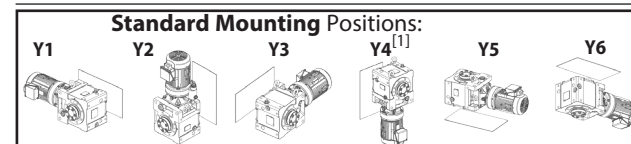

Dimension Pages:  
Single Reduction 2.132-2.143  
Single Reduction, Y2 2.144  
Double Reduction 2.146-2.161  
Double Reduction, Y2 2.162

Frequency	50 Hz	60 Hz
Input Speed	1450 RPM	1750 RPM
Number of Poles	4	

50Hz					60 Hz					Selection							
Output Speed (RPM)	Output Torque		Service Factor		Solid Shaft Overhung Load		Output Speed (RPM)	Output Torque		Service Factor		Solid Shaft Overhung Load		Base			VFD <sup>[2]</sup>
	in-lbs	(N·m)	SF	AGMA Class	lbs	(N)		in-lbs	(N·m)	SF	AGMA Class	lbs	(N)	Motor Power Code	Frame Size	Ratio	
37.7	31000 (3510)		1.01	I	8270 (36800)	45.5	25700 (2910)	1.01	I	8160 (36300)	20	<b>4C145</b>	39				
			1.31	I	8270 (36800)			1.31	I	8160 (36300)	20	<b>4C160</b>	39				
			1.43	II	8270 (36800)			1.47	II	8160 (36300)	20	<b>4C165</b>	39				
			1.61	II	13700 (60900)			1.61	II	13200 (58800)	20	<b>4D165</b>	39				
			1.84	II	13700 (60900)			1.84	II	13200 (58800)	20	<b>4D170</b>	39				
			2.01	III	13700 (60900)			2.01	III	13200 (58800)	20	<b>4D175</b>	39				
			2.44	III	13700 (60900)			2.77	III	13200 (58800)	20	<b>4D180</b>	39				(-)
			2.77	III	18500 (82200)			2.77	III	17700 (78900)	20	<b>4E180</b>	39				(-)
			2.80	III	18500 (82200)			3.00	III	17700 (78900)	20	<b>4E185</b>	39				(-)
			2.80	III	18500 (82200)			3.37	III	17700 (78900)	20	<b>4E190</b>	39				(-)
			2.80	III	18500 (82200)			3.38	III	17700 (78900)	20	<b>4E195</b>	39				(-)
31.9	36700 (4140)		1.01	I	8310 (37000)	38.5	30400 (3430)	1.01	I	8260 (36700)	20	<b>4C145</b>	46				
			1.21	I	8310 (37000)			1.24	I	8260 (36700)	20	<b>4C160</b>	46				
			1.31	I	14100 (62500)			1.31	I	13600 (60600)	20	<b>4D160</b>	46				
			1.51	II	14100 (62500)			1.51	II	13600 (60600)	20	<b>4D165</b>	46				
			1.82	II	14100 (62500)			1.82	II	13600 (60600)	20	<b>4D170</b>	46				
			2.01	III	14100 (62500)			2.01	III	13600 (60600)	20	<b>4D175</b>	46				
			2.10	III	14100 (62500)			2.48	III	13600 (60600)	20	<b>4D180</b>	46				(-)
			2.37	III	19100 (85200)			2.77	III	18400 (81900)	20	<b>4E180</b>	46				(-)
			2.37	III	19100 (85200)			2.86	III	18400 (81900)	20	<b>4E185</b>	46				(-)
			2.37	III	19100 (85200)			2.86	III	18400 (81900)	20	<b>4E190</b>	46				(-)
			2.37	III	19100 (85200)			2.86	III	18400 (81900)	20	<b>4E195</b>	46				(-)
27.6	42300 (4780)		0.96	-	8290 (36900)	33.3	35100 (3960)	0.97	-	8300 (36900)	20	<b>4C145</b>	53				
			1.05	I	8290 (36900)			1.07	I	8300 (36900)	20	<b>4C160</b>	53				
			1.25	I	14400 (63800)			1.25	I	14000 (62100)	20	<b>4D160</b>	53				
			1.49	II	14400 (63800)			1.51	II	14000 (62100)	20	<b>4D165</b>	53				
			1.70	II	14400 (63800)			1.70	II	14000 (62100)	20	<b>4D170</b>	53				
			1.82	II	14400 (63800)			1.82	II	14000 (62100)	20	<b>4D175</b>	53				
			1.82	II	14400 (63800)			2.16	III	14000 (62100)	20	<b>4D180</b>	53				(-)
			2.01	III	19700 (87600)			2.01	III	19000 (84400)	20	<b>4E175</b>	53				
			2.06	III	19700 (87600)			2.16	III	19000 (84400)	20	<b>4E180</b>	53				(-)
			2.06	III	19700 (87600)			2.48	III	19000 (84400)	20	<b>4E185</b>	53				(-)
			2.06	III	19700 (87600)			2.48	III	19000 (84400)	20	<b>4E190</b>	53				(-)
2.06	III	19700 (87600)	2.48	III	19000 (84400)	20	<b>4E195</b>	53	(-)								
2.16	III	30300 (135000)	2.16	III	30700 (136000)	20	<b>4F180</b>	53	(-)								
2.60	III	30300 (135000)	2.60	III	30700 (136000)	20	<b>4F185</b>	53	(-)								

Notes: [1] For Y4 Double Reductions (4XXXDX) refer to the above table; for Y4 single reduction refer to tables on pages 2.91-2.130.

[2] Variable Frequency Drive (VFD) notes (see page 2.8 for Constant Torque Speed Ranges):

All 1HP+ motors require EP suffix in model number and can be used with a VFD, unless noted.

(-) = For Inverter Operation, starting condition may require ambient temperature of 5° C or higher.



# Standard Mounting Selection Tables

**20 HP  
(15 kW)**

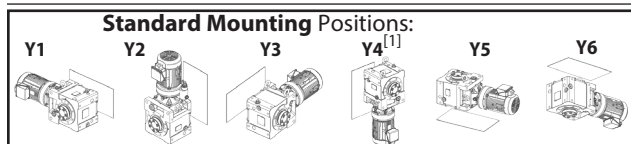

Dimension Pages:  
Single Reduction 2.132-2.143  
Single Reduction, Y2 2.144  
Double Reduction 2.146-2.161  
Double Reduction, Y2 2.162

Frequency	50 Hz	60 Hz
Input Speed	1450 RPM	1750 RPM
Number of Poles	4	

50Hz					60 Hz					Selection							
Output Speed (RPM)	Output Torque		Service Factor		Solid Shaft Overhung Load		Output Speed (RPM)	Output Torque		Service Factor		Solid Shaft Overhung Load		Base			VFD <sup>[2]</sup>
	in-lbs	(N·m)	SF	AGMA Class	lbs	(N)		in-lbs	(N·m)	SF	AGMA Class	lbs	(N)	Motor Power Code	Frame Size	Ratio	
24.4	48000 (5420)		1.25	I	14600 (64800)	29.4	39700 (4490)	1.25	I	14200 (63300)	20	<b>4D165</b>	60				
			1.31	I	14600 (64800)			1.31	I	14200 (63300)	20	<b>4D170</b>	60				
			1.61	II	14600 (64800)			1.61	II	14200 (63300)	20	<b>4D175</b>	60				
			1.61	II	14600 (64800)			1.94	II	14200 (63300)	20	<b>4D180</b>	60				
			1.81	II	20100 (89600)			2.04	III	19400 (86500)	20	<b>4E180</b>	60				
			1.81	II	20100 (89600)			2.19	III	19400 (86500)	20	<b>4E185</b>	60				
			1.81	II	20100 (89600)			2.19	III	19400 (86500)	20	<b>4E190</b>	60				(-)
			1.81	II	20100 (89600)			2.19	III	19400 (86500)	20	<b>4E195</b>	60				(-)
			2.04	III	30100 (134000)			2.04	III	30400 (135000)	20	<b>4F180</b>	60				
			2.55	III	30100 (134000)			2.60	III	30400 (135000)	20	<b>4F185</b>	60				
21.6	54200 (6120)		1.07	I	14800 (65700)	26.0	44900 (5070)	1.07	I	14500 (64300)	20	<b>4D165</b>	67				
			1.24	I	14800 (65700)			1.30	I	14500 (64300)	20	<b>4D170</b>	67				
			1.42	II	14800 (65700)			1.42	II	14500 (64300)	20	<b>4D175</b>	67				
			1.42	II	14800 (65700)			1.72	II	14500 (64300)	20	<b>4D180</b>	67				
			1.57	II	20600 (91500)			1.61	II	19900 (88500)	20	<b>4E175</b>	67				
			1.61	II	20600 (91500)			1.94	II	19900 (88500)	20	<b>4E180</b>	67				
			1.61	II	20600 (91500)			1.94	II	19900 (88500)	20	<b>4E185</b>	67				
			1.61	II	20600 (91500)			1.94	II	19900 (88500)	20	<b>4E190</b>	67				(-)
			1.61	II	20600 (91500)			1.94	II	19900 (88500)	20	<b>4E195</b>	67				(-)
			2.00	III	29800 (133000)			2.00	III	30200 (134000)	20	<b>4F180</b>	67				
			2.54	III	29800 (133000)			2.60	III	30200 (134000)	20	<b>4F185</b>	67				
			2.73	III	29800 (133000)			2.73	III	30200 (134000)	20	<b>4F190</b>	67				(-)
			2.94	III	29800 (133000)			3.21	III	30200 (134000)	20	<b>4F195</b>	67				(-)
			19.7	59300 (6690)				1.07	I	14900 (66200)	23.8	49100 (5550)	1.07				I
1.24	I	14900 (66200)				1.30	I	14600 (65000)	20	<b>4D170</b>			74				
1.30	I	14900 (66200)				1.30	I	14600 (65000)	20	<b>4D175</b>			74				
1.30	I	14900 (66200)				1.57	II	14600 (65000)	20	<b>4D180</b>			74				
1.47	II	20800 (92500)				1.47	II	20200 (90000)	20	<b>4E175</b>			74				
1.47	II	20800 (92500)				1.77	II	20200 (90000)	20	<b>4E180</b>			74				
1.47	II	20800 (92500)				1.77	II	20200 (90000)	20	<b>4E185</b>			74				
1.47	II	20800 (92500)				1.77	II	20200 (90000)	20	<b>4E190</b>			74	(-)			
1.47	II	20800 (92500)				1.77	II	20200 (90000)	20	<b>4E195</b>			74	(-)			
2.00	III	29600 (132000)				2.00	III	30000 (134000)	20	<b>4F180</b>			74				
2.54	III	29600 (132000)				2.60	III	30000 (134000)	20	<b>4F185</b>			74				
2.69	III	29600 (132000)				2.73	III	30000 (134000)	20	<b>4F190</b>			74	(-)			
2.69	III	29600 (132000)				3.21	III	30000 (134000)	20	<b>4F195</b>			74	(-)			

Notes: [1] For Y4 Double Reductions (4XXXDX) refer to the above table; for Y4 single reduction refer to tables on pages 2.91-2.130.

[2] Variable Frequency Drive (VFD) notes (see page 2.8 for Constant Torque Speed Ranges):

All 1HP+ motors require EP suffix in model number and can be used with a VFD, unless noted.

(-) = For Inverter Operation, starting condition may require ambient temperature of 5° C or higher.

# Standard Mounting Selection Tables

**20 HP  
(15 kW)**

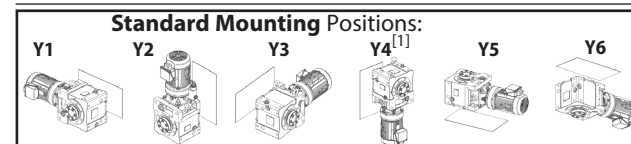

Dimension Pages:  
Single Reduction 2.132-2.143  
Single Reduction, Y2 2.144  
Double Reduction 2.146-2.161  
Double Reduction, Y2 2.162

Frequency	50 Hz	60 Hz
Input Speed	1450 RPM	1750 RPM
Number of Poles	4	

50Hz					60 Hz					Selection														
Output Speed (RPM)	Output Torque		Service Factor		Solid Shaft Overhung Load		Output Speed (RPM)	Output Torque		Service Factor		Solid Shaft Overhung Load		Base			VFD <sup>[2]</sup>							
	in-lbs	(N·m)	SF	AGMA Class	lbs	(N)		in-lbs	(N·m)	SF	AGMA Class	lbs	(N)	Motor Power Code	Frame Size	Ratio								
18.1	64500 (7290)		1.04	I	15000 (66500)	21.9	53400 (6040)	1.05	I	14700 (65600)	20	<b>4D170</b>	80											
			1.20	I	15000 (66500)			1.20	I	14700 (65600)	20	<b>4D175</b>	80											
			1.20	I	15000 (66500)			1.44	II	14700 (65600)	20	<b>4D180</b>	80											
			1.30	I	20500 (91400)			1.30	I	20500 (91300)	20	<b>4E175</b>	80											
			1.35	I	20500 (91400)			1.61	II	20500 (91300)	20	<b>4E180</b>	80											
			1.35	I	20500 (91400)			1.63	II	20500 (91300)	20	<b>4E185</b>	80											
			1.35	I	20500 (91400)			1.63	II	20500 (91300)	20	<b>4E190</b>	80				(-)							
			1.35	I	20500 (91400)			1.63	II	20500 (91300)	20	<b>4E195</b>	80				(-)							
			1.61	II	29400 (131000)			1.61	II	29900 (133000)	20	<b>4F180</b>	80											
			2.01	III	29400 (131000)			2.01	III	29900 (133000)	20	<b>4F185</b>	80											
			2.35	III	29400 (131000)			2.35	III	29900 (133000)	20	<b>4F190</b>	80				(-)							
			2.47	III	29400 (131000)			2.70	III	29900 (133000)	20	<b>4F195</b>	80				(-)							
			16.6	70500 (7970)				0.90	-	13700 (61100)	20.0	58400 (6600)	1.01				I	14900 (66100)	20	<b>4D165</b>	88			
								1.04	I	13700 (61100)			1.05				I	14900 (66100)	20	<b>4D170</b>	88			
1.09	I	13700 (61100)				1.09	I	14900 (66100)	20	<b>4D175</b>			88											
1.09	I	13700 (61100)				1.32	I	14900 (66100)	20	<b>4D180</b>			88											
1.23	I	20200 (90000)				1.23	I	20800 (92600)	20	<b>4E175</b>			88											
1.23	I	20200 (90000)				1.49	II	20800 (92600)	20	<b>4E180</b>			88											
1.23	I	20200 (90000)				1.49	II	20800 (92600)	20	<b>4E185</b>			88											
1.23	I	20200 (90000)				1.49	II	20800 (92600)	20	<b>4E190</b>			88	(-)										
1.23	I	20200 (90000)				1.49	II	20800 (92600)	20	<b>4E195</b>			88	(-)										
1.61	II	29100 (130000)				1.61	II	29600 (132000)	20	<b>4F180</b>			88											
2.01	III	29100 (130000)				2.01	III	29600 (132000)	20	<b>4F185</b>			88											
2.26	III	29100 (130000)				2.35	III	29600 (132000)	20	<b>4F190</b>			88	(-)										
2.26	III	29100 (130000)				2.70	III	29600 (132000)	20	<b>4F195</b>			88	(-)										
14.3	81800 (9250)					0.94	-	9220 (41000)	17.2	67800 (7660)			0.94	-	14500 (64700)	20	<b>4D175</b>	102						
			0.94	-	9220 (41000)	1.14	I	14500 (64700)			20	<b>4D180</b>	102											
			1.06	I	19700 (87400)	1.06	I	20400 (90600)			20	<b>4E175</b>	102											
			1.06	I	19700 (87400)	1.28	I	20400 (90600)			20	<b>4E180</b>	102											
			1.06	I	19700 (87400)	1.28	I	20400 (90600)			20	<b>4E185</b>	102											
			1.06	I	19700 (87400)	1.28	I	20400 (90600)			20	<b>4E190</b>	102											
			1.06	I	19700 (87400)	1.28	I	20400 (90600)			20	<b>4E195</b>	102											
			1.30	I	28600 (127000)	1.30	I	29200 (130000)			20	<b>4F180</b>	102											
			1.61	II	28600 (127000)	1.61	II	29200 (130000)			20	<b>4F185</b>	102											
			1.95	II	28600 (127000)	2.05	III	29200 (130000)			20	<b>4F190</b>	102											
			1.95	II	28600 (127000)	2.35	III	29200 (130000)			20	<b>4F195</b>	102											

Notes: [1] For Y4 Double Reductions (4XXXDX) refer to the above table; for Y4 single reduction refer to tables on pages 2.91-2.130.

[2] Variable Frequency Drive (VFD) notes (see page 2.8 for Constant Torque Speed Ranges):

All 1HP+ motors require EP suffix in model number and can be used with a VFD, unless noted.

(-) = For Inverter Operation, starting condition may require ambient temperature of 5° C or higher.

# Standard Mounting Selection Tables

**20 HP  
(15 kW)**

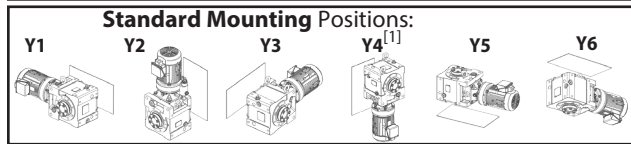

Dimension Pages:  
Single Reduction 2.132-2.143  
Single Reduction, Y2 2.144  
Double Reduction 2.146-2.161  
Double Reduction, Y2 2.162

Frequency	50 Hz	60 Hz
Input Speed	1450 RPM	1750 RPM
Number of Poles	4	

50Hz					60 Hz					Selection							
Output Speed (RPM)	Output Torque		Service Factor		Solid Shaft Overhung Load		Output Speed (RPM)	Output Torque		Service Factor		Solid Shaft Overhung Load		Base			VFD <sup>[2]</sup>
	in-lbs	(N·m)	SF	AGMA Class	lbs	(N)		in-lbs	(N·m)	SF	AGMA Class	lbs	(N)	Motor Power Code	Frame Size	Ratio	
12.9	90300 (10200)		0.85	-	-	-	15.6	74800 (8450)		1.03	I	12300 (54700)	20	<b>4D180</b>	112		
			0.96	-	19200 (85500)	1.01				I	20000 (89000)	20	<b>4E175</b>	112			
			1.14	I	19200 (85500)	1.25				I	20000 (89000)	20	<b>4E180</b>	112			
			1.14	I	19200 (85500)	1.37				I	20000 (89000)	20	<b>4E185</b>	112			
			1.23	I	28300 (126000)	1.25				I	28900 (129000)	20	<b>4F180</b>	112			
			1.51	II	28300 (126000)	1.51				II	28900 (129000)	20	<b>4F185</b>	112			
			1.62	II	28300 (126000)	1.62				II	28900 (129000)	20	<b>4F190</b>	112			
			1.76	II	28300 (126000)	2.01				III	28900 (129000)	20	<b>4F195</b>	112			
11.8	98800 (11200)		0.96	-	18800 (83600)	-	14.3	81800 (9250)		1.01	I	19700 (87400)	20	<b>4E175</b>	123		
			1.04	I	18800 (83600)	1.25				I	19700 (87400)	20	<b>4E180</b>	123			
			1.04	I	18800 (83600)	1.25				I	19700 (87400)	20	<b>4E185</b>	123			
			1.23	I	27900 (124000)	1.25				I	28600 (127000)	20	<b>4F180</b>	123			
			1.51	II	27900 (124000)	1.51				II	28600 (127000)	20	<b>4F185</b>	123			
			1.61	II	27900 (124000)	1.62				II	28600 (127000)	20	<b>4F190</b>	123			
			1.61	II	27900 (124000)	1.95				II	28600 (127000)	20	<b>4F195</b>	123			
			9.63	121000 (13700)		0.85				-	12500 (55800)	-	11.6	101000 (11400)		1.01	I
0.85	-	12500 (55800)				1.02	I	18700 (83200)	20	<b>4E185</b>	151						
1.00	I	26900 (120000)				1.01	I	27800 (124000)	20	<b>4F180</b>	151						
1.24	I	26900 (120000)				1.25	I	27800 (124000)	20	<b>4F185</b>	151						
1.31	I	26900 (120000)				1.39	I	27800 (124000)	20	<b>4F190</b>	151						
1.31	I	26900 (120000)				1.58	II	27800 (124000)	20	<b>4F195</b>	151						
8.12	144000 (16300)		1.01	I	25900 (115000)	-	9.80	119000 (13500)		1.01	I	27000 (120000)	20	<b>4F185</b>	179		
			1.11	I	25900 (115000)	1.21				I	27000 (120000)	20	<b>4F190</b>	179			
			1.11	I	25900 (115000)	1.34				I	27000 (120000)	20	<b>4F195</b>	179			
7.02	166000 (18800)		0.96	-	25000 (111000)	-	8.47	138000 (15600)		1.02	I	26200 (117000)	20	<b>4F190</b>	207		
			0.96	-	25000 (111000)	1.15				I	26200 (117000)	20	<b>4F195</b>	207			

Notes: [1] For Y4 Double Reductions (4XXXDX) refer to the above table; for Y4 single reduction refer to tables on pages 2.91-2.130.

[2] Variable Frequency Drive (VFD) notes (see page 2.8 for Constant Torque Speed Ranges):  
All 1HP+ motors require EP suffix in model number and can be used with a VFD, unless noted.

# Standard Mounting Selection Tables

**25 HP  
(18.5 kW)**

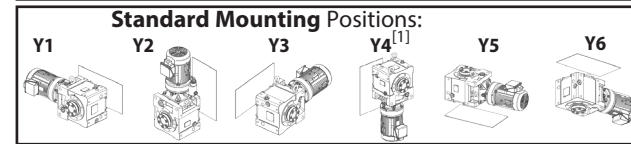

Dimension Pages:  
Single Reduction 2.132-2.143  
Single Reduction, Y2 2.144  
Double Reduction 2.146-2.161  
Double Reduction, Y2 2.162

Frequency	50 Hz	60 Hz
Input Speed	1450 RPM	1750 RPM
Number of Poles	4	

50Hz					60 Hz					Selection							
Output Speed (RPM)	Output Torque		Service Factor		Solid Shaft Overhung Load		Output Speed (RPM)	Output Torque		Service Factor		Solid Shaft Overhung Load		Base			VFD <sup>[2]</sup>
	in-lbs	(N·m)	SF	AGMA Class	lbs	(N)		in-lbs	(N·m)	SF	AGMA Class	lbs	(N)	Motor Power Code	Frame Size	Ratio	
138	10400 (1180)		1.37	I	4410 (19600)	-	167	8650 (977)		1.37	I	4310 (19200)	25	<b>4B160</b>	11		
			1.57	II	4410 (19600)	1.57				II	4310 (19200)	25	<b>4B165</b>	11			
			1.62	II	6640 (29600)	1.62				II	6400 (28500)	25	<b>4C165</b>	11	(#)		
			2.24	III	6650 (29600)	2.24				III	6400 (28500)	25	<b>4C170</b>	11	(#)		
			2.43	III	6650 (29600)	2.43				III	6400 (28500)	25	<b>4C175</b>	11	(#)		
			2.24	III	10200 (45400)	2.24				III	9740 (43300)	25	<b>4D170</b>	11	(#)		
			2.43	III	10200 (45400)	2.43				III	9740 (43300)	25	<b>4D175</b>	11	(#)		
			2.89	III	10100 (45000)	2.89				III	9660 (43000)	25	<b>4D180</b>	11	(-),(#)		
113	12700 (1440)		1.37	I	4490 (20000)	-	137	10500 (1190)		1.37	I	4400 (19600)	25	<b>4B160</b>	13		
			1.57	II	4490 (20000)	1.57				II	4400 (19600)	25	<b>4B165</b>	13			
			1.62	II	6850 (30500)	1.62				II	6610 (29400)	25	<b>4C165</b>	13	(#)		
			2.24	III	6880 (30600)	2.24				III	6640 (29500)	25	<b>4C170</b>	13	(#)		
			2.43	III	6880 (30600)	2.43				III	6640 (29500)	25	<b>4C175</b>	13	(#)		
			2.24	III	10700 (47400)	2.24				III	10200 (45400)	25	<b>4D170</b>	13	(#)		
			2.43	III	10700 (47400)	2.43				III	10200 (45400)	25	<b>4D175</b>	13	(#)		
			2.89	III	10700 (47400)	2.89				III	10200 (45400)	25	<b>4D180</b>	13	(-),(#)		
104	13900 (1570)		1.37	I	4520 (20100)	-	125	11500 (1300)		1.37	I	4450 (19800)	25	<b>4B160</b>	14		
			1.51	II	4520 (20100)	1.51				II	4450 (19800)	25	<b>4B165</b>	14			
			1.62	II	6960 (30900)	1.62				II	6730 (29900)	25	<b>4C165</b>	14	(#)		
			2.24	III	6980 (31100)	2.24				III	6760 (30100)	25	<b>4C170</b>	14	(#)		
			2.43	III	6980 (31100)	2.43				III	6760 (30100)	25	<b>4C175</b>	14	(#)		
			2.24	III	10900 (48400)	2.24				III	10400 (46300)	25	<b>4D170</b>	14	(#)		
			2.43	III	10900 (48400)	2.43				III	10400 (46300)	25	<b>4D175</b>	14	(#)		
			2.89	III	10900 (48400)	2.89				III	10400 (46300)	25	<b>4D180</b>	14	(-),(#)		
90.6	15900 (1800)		1.35	I	4550 (20200)	-	109	13200 (1490)		1.43	II	4510 (20000)	25	<b>4B165</b>	16		
			1.62	II	7120 (31700)	1.62				II	6910 (30700)	25	<b>4C165</b>	16	(#)		
			2.24	III	7120 (31700)	2.24				III	6900 (30700)	25	<b>4C170</b>	16	(#)		
			2.39	III	7120 (31700)	2.43				III	6900 (30700)	25	<b>4C175</b>	16	(#)		
			2.24	III	11200 (49700)	2.24				III	10700 (47700)	25	<b>4D170</b>	16	(#)		
			2.43	III	11200 (49700)	2.43				III	10700 (47700)	25	<b>4D175</b>	16	(#)		
			2.43	III	11200 (49700)	2.43				III	10700 (47700)	25	<b>4D175</b>	16	(#)		
			2.89	III	11100 (49400)	2.89				III	10600 (47300)	25	<b>4D180</b>	16	(-),(#)		

Notes: [1] For Y4 Double Reductions (4XXXDX) refer to the above table; for Y4 single reduction refer to tables on pages 2.91-2.130.

[2] Variable Frequency Drive (VFD) notes (see page 2.8 for Constant Torque Speed Ranges):  
All 1HP+ motors require EP suffix in model number and can be used with a VFD, unless noted.  
(-) = For Inverter Operation, starting condition may require ambient temperature of 5° C or higher.  
(#) = Mounting positions Y2, F2, G2, K2, V2, W2 operation is limited to 75 %ED (duty cycle) for a 10 minute total cycle (7.5 minutes max. on time).

# Standard Mounting Selection Tables

**25 HP**  
(18.5 kW)

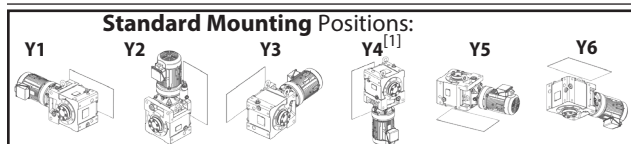

Dimension Pages:  
Single Reduction 2.132-2.143  
Single Reduction, Y2 2.144  
Double Reduction 2.146-2.161  
Double Reduction, Y2 2.162

Frequency	50 Hz	60 Hz
Input Speed	1450 RPM	1750 RPM
Number of Poles	4	

50Hz					60 Hz					Selection					
Output Speed (RPM)	Output Torque		Service Factor	Solid Shaft Overhung Load	Output Speed (RPM)	Output Torque		Service Factor	Solid Shaft Overhung Load	Base			VFD <sup>[2]</sup>		
	in-lbs	(N·m)				in-lbs	(N·m)			Motor Power Code	Frame Size	Ratio			
82.9	17400 (1970)		1.28	I	4560 (20300)	100.0	14400 (1630)		1.31	I	4530 (20200)	25	<b>4B160</b>	18	
			1.37	I	7220 (32100)				1.37	I	7010 (31200)	25	<b>4C160</b>	18	
			1.62	II	7220 (32100)				1.62	II	7010 (31200)	25	<b>4C165</b>	18	
			2.24	III	7210 (32100)				2.24	III	7010 (31200)	25	<b>4C170</b>	18	(#)
			2.24	III	7210 (32100)				2.43	III	7010 (31200)	25	<b>4C175</b>	18	(#)
			2.24	III	11400 (50700)				2.24	III	10900 (48600)	25	<b>4D170</b>	18	(#)
			2.43	III	11400 (50700)				2.43	III	10900 (48600)	25	<b>4D175</b>	18	(#)
			2.89	III	11300 (50300)				2.89	III	10900 (48300)	25	<b>4D180</b>	18	(-),(#)
69.0	20900 (2360)		1.09	I	4550 (20200)	83.3	17300 (1950)		1.09	I	4560 (20300)	25	<b>4B160</b>	21	
			1.37	I	7370 (32800)				1.37	I	7190 (32000)	25	<b>4C160</b>	21	
			1.62	II	7370 (32800)				1.62	II	7190 (32000)	25	<b>4C165</b>	21	
			1.83	II	7370 (32800)				1.83	II	7190 (32000)	25	<b>4C170</b>	21	
			1.95	II	7370 (32800)				1.95	II	7190 (32000)	25	<b>4C175</b>	21	
			2.00	III	11800 (52500)				2.00	III	11400 (50500)	25	<b>4D175</b>	21	
			2.24	III	11800 (52500)				2.24	III	11400 (50500)	25	<b>4D180</b>	21	(-),(#)
			2.43	III	11800 (52500)				2.43	III	11400 (50500)	25	<b>4D185</b>	21	(-),(#)
64.7	22300 (2520)		1.02	I	4530 (20100)	78.1	18500 (2090)		1.02	I	4560 (20300)	25	<b>4B160</b>	22	
			1.10	I	7420 (33000)				1.10	I	7260 (32300)	25	<b>4C160</b>	22	
			1.30	I	7420 (33000)				1.30	I	7260 (32300)	25	<b>4C165</b>	22	
			1.83	II	7420 (33000)				1.83	II	7260 (32300)	25	<b>4C170</b>	22	
			2.00	III	12000 (53200)				2.00	III	11500 (51200)	25	<b>4D175</b>	22	
			2.24	III	12000 (53200)				2.24	III	11500 (51200)	25	<b>4D180</b>	22	(-),(#)
			2.43	III	12000 (53200)				2.43	III	11500 (51200)	25	<b>4D185</b>	22	(-),(#)
			2.74	III	16000 (71200)				2.74	III	15300 (68200)	25	<b>4E190</b>	22	(-),(#)
59.2	24400 (2750)		0.93	-	4490 (20000)	71.4	20200 (2280)		0.93	-	4550 (20300)	25	<b>4B160</b>	25	
			1.10	I	7480 (33300)				1.10	I	7340 (32600)	25	<b>4C160</b>	25	
			1.30	I	7480 (33300)				1.30	I	7340 (32600)	25	<b>4C165</b>	25	
			1.75	II	7480 (33300)				1.87	II	7340 (32600)	25	<b>4C175</b>	25	
			1.83	II	12200 (54100)				1.83	II	11700 (52200)	25	<b>4D170</b>	25	
			2.00	III	12200 (54100)				2.00	III	11700 (52200)	25	<b>4D175</b>	25	
			2.24	III	12200 (54100)				2.24	III	11700 (52200)	25	<b>4D180</b>	25	(-),(#)
			2.43	III	12200 (54100)				2.43	III	11700 (52200)	25	<b>4D185</b>	25	(-),(#)
51.8	27800 (3150)		1.06	I	7550 (33600)	62.5	23100 (2610)		1.06	I	7550 (33600)	25	<b>4C160</b>	28	
			1.30	I	7550 (33600)				1.30	I	7440 (33100)	25	<b>4C165</b>	28	
			1.59	II	7550 (33600)				1.59	II	7440 (33100)	25	<b>4C170</b>	28	
			1.83	II	12500 (55400)				1.83	II	12000 (53600)	25	<b>4D170</b>	28	
			2.00	III	12500 (55400)				2.00	III	12000 (53600)	25	<b>4D175</b>	28	
			2.24	III	12500 (55400)				2.24	III	12000 (53600)	25	<b>4D180</b>	28	(-),(#)
			2.43	III	12500 (55400)				2.43	III	12000 (53600)	25	<b>4D185</b>	28	(-),(#)
			2.24	III	16800 (74900)				2.24	III	16100 (71800)	25	<b>4E180</b>	28	(-),(#)
41.2	35000 (3950)		1.06	I	7590 (33800)	49.7	29000 (3280)		1.06	I	7560 (33600)	25	<b>4C160</b>	35	
			1.30	I	7590 (33800)				1.30	I	7560 (33600)	25	<b>4C165</b>	35	
			1.49	II	12900 (57500)				1.49	II	12600 (55800)	25	<b>4D170</b>	35	
			1.63	II	12900 (57500)				1.63	II	12600 (55800)	25	<b>4D175</b>	35	
			2.15	III	12900 (57500)				2.15	III	12600 (55800)	25	<b>4D180</b>	35	(#)
			2.24	III	17600 (78500)				2.24	III	17000 (75500)	25	<b>4E180</b>	35	(#)
			2.43	III	17600 (78500)				2.43	III	17000 (75500)	25	<b>4E185</b>	35	(#)
			2.49	III	17600 (78500)				2.49	III	17000 (75500)	25	<b>4E190</b>	35	(-),(#)
37.7	38300 (4330)		1.06	I	7580 (33700)	45.5	31700 (3580)		1.06	I	7590 (33800)	25	<b>4C160</b>	39	
			1.16	I	7580 (33700)				1.16	I	7590 (33800)	25	<b>4C165</b>	39	
			1.30	I	13100 (58300)				1.30	I	12700 (56700)	25	<b>4D165</b>	39	
			1.49	II	13100 (58300)				1.49	II	12700 (56700)	25	<b>4D170</b>	39	
			1.63	II	13100 (58300)				1.63	II	12700 (56700)	25	<b>4D175</b>	39	
			1.98	II	13100 (58300)				1.98	II	12700 (56700)	25	<b>4D180</b>	39	
			2.24	III	18000 (79900)				2.24	III	17300 (77000)	25	<b>4E180</b>	39	
			2.27	III	18000 (79900)				2.27	III	17300 (77000)	25	<b>4E185</b>	39	

**Notes:** [1] For Y4 Double Reductions (4XXXDX) refer to the above table; for Y4 single reduction refer to tables on pages 2.91-2.130.  
[2] Variable Frequency Drive (VFD) notes (see page 2.8 for Constant Torque Speed Ranges):  
All 1HP+ motors require EP suffix in model number and can be used with a VFD, unless noted.  
(-) = For Inverter Operation, starting condition may require ambient temperature of 5° C or higher.  
(#) = Mounting positions Y2, F2, G2, K2, V2, W2 operation is limited to 75 %ED (duty cycle) for a 10 minute total cycle (7.5 minutes max. on time).

# Standard Mounting Selection Tables

**25 HP**  
(18.5 kW)

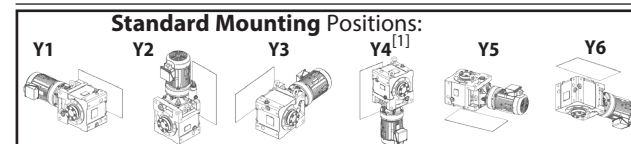

Dimension Pages:  
Single Reduction 2.132-2.143  
Single Reduction, Y2 2.144  
Double Reduction 2.146-2.161  
Double Reduction, Y2 2.162

Frequency	50 Hz	60 Hz
Input Speed	1450 RPM	1750 RPM
Number of Poles	4	

50Hz					60 Hz					Selection					
Output Speed (RPM)	Output Torque		Service Factor	Solid Shaft Overhung Load	Output Speed (RPM)	Output Torque		Service Factor	Solid Shaft Overhung Load	Base			VFD <sup>[2]</sup>		
	in-lbs	(N·m)				in-lbs	(N·m)			Motor Power Code	Frame Size	Ratio			
51.8	27800 (3150)		1.06	I	7550 (33600)	62.5	23100 (2610)		1.06	I	7440 (33100)	25	<b>4C160</b>	28	
			1.30	I	7550 (33600)				1.30	I	7440 (33100)	25	<b>4C165</b>	28	
			1.59	II	7550 (33600)				1.59	II	7440 (33100)	25	<b>4C170</b>	28	
			1.83	II	12500 (55400)				1.83	II	12000 (53600)	25	<b>4D170</b>	28	
			2.00	III	12500 (55400)				2.00	III	12000 (53600)	25	<b>4D175</b>	28	
			2.24	III	12500 (55400)				2.24	III	12000 (53600)	25	<b>4D180</b>	28	(-),(#)
			2.43	III	12500 (55400)				2.43	III	12000 (53600)	25	<b>4D185</b>	28	(-),(#)
			2.24	III	16800 (74900)				2.24	III	16100 (71800)	25	<b>4E180</b>	28	(-),(#)
41.2	35000 (3950)		1.06	I	7590 (33800)	49.7	29000 (3280)		1.06	I	7560 (33600)	25	<b>4C160</b>	35	
			1.30	I	7590 (33800)				1.30	I	7560 (33600)	25	<b>4C165</b>	35	
			1.49	II	12900 (57500)				1.49	II	12600 (55800)	25	<b>4D170</b>	35	
			1.63	II	12900 (57500)				1.63	II	12600 (55800)	25	<b>4D175</b>	35	
			2.15	III	12900 (57500)				2.15	III	12600 (55800)	25	<b>4D180</b>	35	(#)
			2.24	III	17600 (78500)				2.24	III	17000 (75500)	25	<b>4E180</b>	35	(#)
			2.43	III	17600 (78500)				2.43	III	17000 (75500)	25	<b>4E185</b>	35	(#)
			2.49	III	17600 (78500)				2.49	III	17000 (75500)	25	<b>4E190</b>	35	(-),(#)
37.7	38300 (4330)		1.06	I	7580 (33700)	45.5	31700 (3580)		1.06	I	7590 (33800)	25	<b>4C160</b>	39	
			1.16	I	7580 (33700)				1.16	I	7590 (33800)	25	<b>4C165</b>	39	
			1.30	I	13100 (58300)				1.30	I	12700 (56700)	25	<b>4D165</b>	39	
			1.49	II	13100 (58300)				1.49	II	12700 (56700)	25	<b>4D170</b>	39	
			1.63	II	13100 (58300)				1.63	II	12700 (56700)	25	<b>4D175</b>	39	
			1.98	II	13100 (58300)				1.98	II	12700 (56700)	25	<b>4D180</b>	39	
			2.24	III	18000 (79900)				2.24	III	17300 (77000)	25	<b>4E180</b>	39	
			2.27	III	18000 (79900)				2.27	III	17300 (77000)	25	<b>4E185</b>	39	

**Notes:** [1] For Y4 Double Reductions (4XXXDX) refer to the above table; for Y4 single reduction refer to tables on pages 2.91-2.130.  
[2] Variable Frequency Drive (VFD) notes (see page 2.8 for Constant Torque Speed Ranges):  
All 1HP+ motors require EP suffix in model number and can be used with a VFD, unless noted.  
(-) = For Inverter Operation, starting condition may require ambient temperature of 5° C or higher.  
(#) = Mounting positions Y2, F2, G2, K2, V2, W2 operation is limited to 75 %ED (duty cycle) for a 10 minute total cycle (7.5 minutes max. on time).

# Standard Mounting Selection Tables

**25 HP**  
(18.5 kW)

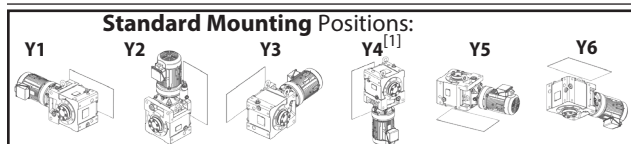

Dimension Pages:  
Single Reduction, Y2 2.132-2.143  
Single Reduction, Y2 2.144  
Double Reduction 2.146-2.161  
Double Reduction, Y2 2.162

Frequency	50 Hz	60 Hz
Input Speed	1450 RPM	1750 RPM
Number of Poles	4	

50Hz					60 Hz					Selection							
Output Speed (RPM)	Output Torque		Service Factor		Solid Shaft Overhung Load		Output Speed (RPM)	Output Torque		Service Factor		Solid Shaft Overhung Load		Base			VFD <sup>[2]</sup>
	in-lbs	(N·m)	SF	AGMA Class	lbs	(N)		in-lbs	(N·m)	SF	AGMA Class	lbs	(N)	Motor Power Code	Frame Size	Ratio	
31.9	45200 (5110)		0.98	-	7500 (33400)	38.5	37500 (4240)	1.01	I	7590 (33800)	25	<b>4C160</b>	46				
			1.22	I	13400 (59500)			25	<b>4D165</b>	46							
			1.48	II	13400 (59500)			25	<b>4D170</b>	46							
			1.63	II	13400 (59500)			25	<b>4D175</b>	46							
			1.71	II	13400 (59500)			25	<b>4D180</b>	46							
			1.92	II	18500 (82400)			25	<b>4E180</b>	46							
			1.92	II	18500 (82400)			25	<b>4E185</b>	46							
			1.92	II	18500 (82400)			25	<b>4E190</b>	46	(-)						
			1.92	II	18500 (82400)			25	<b>4E195</b>	46	(-)						
			2.24	III	30200 (134000)			25	<b>4F180</b>	46							
			2.43	III	30200 (134000)			25	<b>4F185</b>	46							
			2.74	III	30200 (134000)			25	<b>4F190</b>	46	(-)						
			2.97	III	30200 (134000)			25	<b>4F195</b>	46	(-)						
27.6	52200 (5900)		0.85	-	5880 (26100)	33.3	43300 (4890)	0.87	-	7530 (33500)	25	<b>4C160</b>	53				
			1.01	I	13600 (60300)			25	<b>4D160</b>	53							
			1.21	I	13600 (60300)			25	<b>4D165</b>	53							
			1.38	I	13600 (60300)			25	<b>4D170</b>	53							
			1.48	II	13600 (60300)			25	<b>4D175</b>	53							
			1.48	II	13600 (60300)			25	<b>4D180</b>	53							
			1.63	II	19000 (84400)			25	<b>4E175</b>	53							
			1.67	II	19000 (84400)			25	<b>4E180</b>	53							
			1.67	II	19000 (84400)			25	<b>4E185</b>	53							
			1.67	II	19000 (84400)			25	<b>4E190</b>	53	(-)						
			1.67	II	19000 (84400)			25	<b>4E195</b>	53	(-)						
			1.75	II	29900 (133000)			25	<b>4F180</b>	53							
			2.11	III	29900 (133000)			25	<b>4F185</b>	53							
			2.74	III	29900 (133000)			25	<b>4F190</b>	53	(-)						
			2.97	III	29900 (133000)			25	<b>4F195</b>	53	(-)						

# Standard Mounting Selection Tables

**25 HP**  
(18.5 kW)

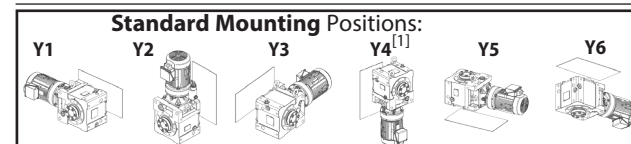

Dimension Pages:  
Single Reduction 2.132-2.143  
Single Reduction, Y2 2.144  
Double Reduction 2.146-2.161  
Double Reduction, Y2 2.162

Frequency	50 Hz	60 Hz
Input Speed	1450 RPM	1750 RPM
Number of Poles	4	

50Hz					60 Hz					Selection							
Output Speed (RPM)	Output Torque		Service Factor		Solid Shaft Overhung Load		Output Speed (RPM)	Output Torque		Service Factor		Solid Shaft Overhung Load		Base			VFD <sup>[2]</sup>
	in-lbs	(N·m)	SF	AGMA Class	lbs	(N)		in-lbs	(N·m)	SF	AGMA Class	lbs	(N)	Motor Power Code	Frame Size	Ratio	
24.4	59200 (6680)		1.02	I	13700 (60800)	29.4	49000 (5540)	1.02	I	13500 (60000)	25	<b>4D165</b>	60				
			1.06	I	13700 (60800)			25	<b>4D170</b>	60							
			1.30	I	13700 (60800)			25	<b>4D175</b>	60							
			1.30	I	13700 (60800)			25	<b>4D180</b>	60							
			1.47	II	19300 (86000)			25	<b>4E180</b>	60							
			1.47	II	19300 (86000)			25	<b>4E185</b>	60							
			1.47	II	19300 (86000)			25	<b>4E190</b>	60	(-)						
			1.47	II	19300 (86000)			25	<b>4E195</b>	60	(-)						
			1.65	II	29600 (132000)			25	<b>4F180</b>	60							
			2.06	III	29600 (132000)			25	<b>4F185</b>	60							
			2.69	III	29600 (132000)			25	<b>4F190</b>	60	(-)						
			2.69	III	29600 (132000)			25	<b>4F195</b>	60	(-)						
			21.6	66800 (7550)				1.00	I	13700 (61100)	26.0	55400 (6260)	1.05				I
1.16	I	13700 (61100)				25	<b>4D175</b>	67									
1.16	I	13700 (61100)				25	<b>4D180</b>	67									
1.27	I	19600 (87400)				25	<b>4E175</b>	67									
1.30	I	19600 (87400)				25	<b>4E180</b>	67									
1.30	I	19600 (87400)				25	<b>4E185</b>	67									
1.30	I	19600 (87400)				25	<b>4E190</b>	67	(-)								
1.30	I	19600 (87400)				25	<b>4E195</b>	67	(-)								
1.62	II	29300 (130000)				25	<b>4F180</b>	67									
2.06	III	29300 (130000)				25	<b>4F185</b>	67									
2.22	III	29300 (130000)				25	<b>4F190</b>	67	(-)								
2.38	III	29300 (130000)				25	<b>4F195</b>	67	(-)								
19.7	73100 (8260)					0.86	-	12900 (57400)	23.8	60600 (6840)			0.87	-	13700 (60900)	25	<b>4D165</b>
			1.00	I	12900 (57400)	25	<b>4D170</b>	74									
			1.06	I	12900 (57400)	25	<b>4D175</b>	74									
			1.06	I	12900 (57400)	25	<b>4D180</b>	74									
			1.19	I	19900 (88300)	25	<b>4E175</b>	74									
			1.19	I	19900 (88300)	25	<b>4E180</b>	74									
			1.19	I	19900 (88300)	25	<b>4E185</b>	74									
			1.19	I	19900 (88300)	25	<b>4E190</b>	74									
			1.19	I	19900 (88300)	25	<b>4E195</b>	74									
			1.62	II	29000 (129000)	25	<b>4F180</b>	74									
			2.06	III	29000 (129000)	25	<b>4F185</b>	74									
			2.18	III	29000 (129000)	25	<b>4F190</b>	74									
			2.18	III	29000 (129000)	25	<b>4F195</b>	74									

Notes: [1] For Y4 Double Reductions (4XXXDX) refer to the above table; for Y4 single reduction refer to tables on pages 2.91-2.130.

[2] Variable Frequency Drive (VFD) notes (see page 2.8 for Constant Torque Speed Ranges):

All 1HP+ motors require EP suffix in model number and can be used with a VFD, unless noted.

(-) = For Inverter Operation, starting condition may require ambient temperature of 5° C or higher.

Notes: [1] For Y4 Double Reductions (4XXXDX) refer to the above table; for Y4 single reduction refer to tables on pages 2.91-2.130.

[2] Variable Frequency Drive (VFD) notes (see page 2.8 for Constant Torque Speed Ranges):

All 1HP+ motors require EP suffix in model number and can be used with a VFD, unless noted.

(-) = For Inverter Operation, starting condition may require ambient temperature of 5° C or higher.



# Standard Mounting Selection Tables

**25 HP  
(18.5 kW)**

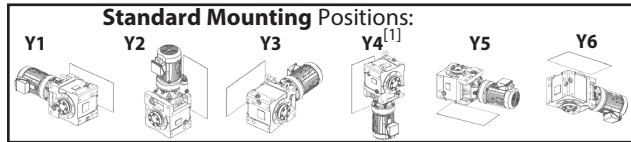

Dimension Pages:  
Single Reduction 2.132-2.143  
Single Reduction, Y2 2.144  
Double Reduction 2.146-2.161  
Double Reduction, Y2 2.162

Frequency	50 Hz	60 Hz
Input Speed	1450 RPM	1750 RPM
Number of Poles	4	

50Hz				60 Hz				Selection							
Output Speed (RPM)	Output Torque		Service Factor	Solid Shaft Overhung Load		Output Speed (RPM)	Output Torque		Service Factor	Solid Shaft Overhung Load		Base			VFD <sup>[2]</sup>
	in-lbs	(N·m)		lbs	(N)		in-lbs	(N·m)		lbs	(N)	Motor Power Code	Frame Size	Ratio	
18.1	79500 (8990)		0.97	-	10400 (46100)	21.9	65900 (7450)		0.97	-	13700 (61100)	25	4D175	80	
			0.97	-	10400 (46100)				1.17	I	13700 (61100)				
			1.05	I	19800 (88000)				1.05	I	19600 (87200)				
			1.09	I	19800 (88000)				1.30	I	19600 (87200)				
			1.09	I	19800 (88000)				1.32	I	19600 (87200)				
			1.09	I	19800 (88000)				1.32	I	19600 (87200)				
			1.09	I	19800 (88000)				1.32	I	19600 (87200)				
			1.30	I	28700 (128000)				1.30	I	29300 (130000)				
			1.63	II	28700 (128000)				1.63	II	29300 (130000)				
			1.90	II	28700 (128000)				1.90	II	29300 (130000)				
2.00	III	28700 (128000)	2.19	III	29300 (130000)										
16.6	87000 (9830)		0.89	-	5680 (25300)	20.0	72100 (8140)		1.07	I	13200 (58900)	25	4D180	88	
			1.00	I	19400 (86300)				1.00	I	19800 (88200)				
			1.00	I	19400 (86300)				1.21	I	19800 (88200)				
			1.00	I	19400 (86300)				1.21	I	19800 (88200)				
			1.00	I	19400 (86300)				1.21	I	19800 (88200)				
			1.00	I	19400 (86300)				1.21	I	19800 (88200)				
			1.00	I	19400 (86300)				1.21	I	19800 (88200)				
			1.30	I	28400 (126000)				1.30	I	29100 (129000)				
			1.63	II	28400 (126000)				1.63	II	29100 (129000)				
			1.83	II	28400 (126000)				1.90	II	29100 (129000)				
1.83	II	28400 (126000)	2.19	III	29100 (129000)										
14.3	101000 (11400)		0.86	-	18700 (83100)	17.2	83600 (9450)		0.86	-	19600 (87000)	25	4E175	102	
			0.86	-	18700 (83100)				1.04	I	19600 (87000)				
			0.86	-	18700 (83100)				1.04	I	19600 (87000)				
			0.86	-	18700 (83100)				1.04	I	19600 (87000)				
			0.86	-	18700 (83100)				1.04	I	19600 (87000)				
			1.05	I	27800 (124000)				1.05	I	28600 (127000)				
			1.30	I	27800 (124000)				1.30	I	28600 (127000)				
			1.58	II	27800 (124000)				1.66	II	28600 (127000)				
			1.58	II	27800 (124000)				1.91	II	28600 (127000)				
12.9	111000 (12600)		0.92	-	16100 (71500)	15.6	92300 (10400)		1.02	I	19100 (85100)	25	4E180	112	
			0.92	-	16100 (71500)				1.11	I	19100 (85100)				
			1.00	I	27400 (122000)				1.02	I	28200 (125000)				
			1.22	I	27400 (122000)				1.22	I	28200 (125000)				
			1.31	I	27400 (122000)				1.31	I	28200 (125000)				
			1.43	II	27400 (122000)				1.63	II	28200 (125000)				

Notes: [1] For Y4 Double Reductions (4XXXDX) refer to the above table; for Y4 single reduction refer to tables on pages 2.91-2.130.  
[2] Variable Frequency Drive (VFD) notes (see page 2.8 for Constant Torque Speed Ranges):  
All 1HP+ motors require EP suffix in model number and can be used with a VFD, unless noted.

# Standard Mounting Selection Tables

**25 HP  
(18.5 kW)**

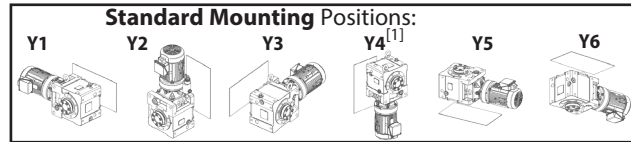

Dimension Pages:  
Single Reduction 2.132-2.143  
Single Reduction, Y2 2.144  
Double Reduction 2.146-2.161  
Double Reduction, Y2 2.162

Frequency	50 Hz	60 Hz
Input Speed	1450 RPM	1750 RPM
Number of Poles	4	

50Hz				60 Hz				Selection							
Output Speed (RPM)	Output Torque		Service Factor	Solid Shaft Overhung Load		Output Speed (RPM)	Output Torque		Service Factor	Solid Shaft Overhung Load		Base			VFD <sup>[2]</sup>
	in-lbs	(N·m)		lbs	(N)		in-lbs	(N·m)		lbs	(N)	Motor Power Code	Frame Size	Ratio	
11.8	122000 (13800)		0.84	-	12300 (54900)	14.3	101000 (11400)		1.02	I	18700 (83100)	25	4E180	123	
			0.84	-	12300 (54900)				1.02	I	18700 (83100)				
			1.00	I	26900 (120000)				1.02	I	27800 (124000)				
			1.22	I	26900 (120000)				1.22	I	27800 (124000)				
			1.31	I	26900 (120000)				1.31	I	27800 (124000)				
			1.31	I	26900 (120000)				1.58	II	27800 (124000)				
			1.31	I	26900 (120000)				1.58	II	27800 (124000)				
9.63	150000 (16900)		0.81	-	25700 (114000)	11.6	124000 (14000)		0.82	-	26800 (119000)	25	4F180	151	
			1.00	I	25700 (114000)				1.02	I	26800 (119000)				
			1.06	I	25700 (114000)				1.13	I	26800 (119000)				
			1.06	I	25700 (114000)				1.28	I	26800 (119000)				
8.12	177000 (20100)		0.82	-	24500 (109000)	9.80	147000 (16600)		0.82	-	25800 (115000)	25	4F185	179	
			0.90	-	24500 (109000)				0.98	-	25800 (115000)				
			0.90	-	24500 (109000)				1.08	I	25800 (115000)				

Notes: [1] For Y4 Double Reductions (4XXXDX) refer to the above table; for Y4 single reduction refer to tables on pages 2.91-2.130.  
[2] Variable Frequency Drive (VFD) notes (see page 2.8 for Constant Torque Speed Ranges):  
All 1HP+ motors require EP suffix in model number and can be used with a VFD, unless noted.

Selection Tables

Selection Tables

# Standard Mounting Selection Tables

**30 HP  
(22 kW)**

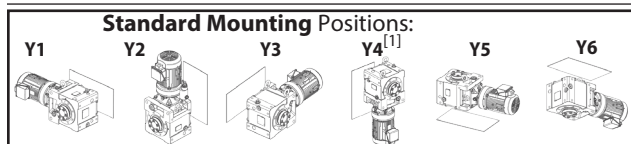

Dimension Pages:  
Single Reduction 2.132-2.143  
Single Reduction, Y2 2.144  
Double Reduction 2.146-2.161  
Double Reduction, Y2 2.162

Frequency	50 Hz	60 Hz
Input Speed	1450 RPM	1750 RPM
Number of Poles	4	

50Hz					60 Hz					Selection							
Output Speed (RPM)	Output Torque		Service Factor		Solid Shaft Overhung Load		Output Speed (RPM)	Output Torque		Service Factor		Solid Shaft Overhung Load		Base			VFD <sup>[2]</sup>
	in-lbs	(N·m)	SF	AGMA Class	lbs	(N)		in-lbs	(N·m)	SF	AGMA Class	lbs	(N)	Motor Power Code	Frame Size	Ratio	
138	12400 (1400)		1.15	I	4190 (18700)	167	10300 (1160)	1.15	I	4130 (18300)	30	<b>4B160</b>	11				
			1.32	I	4190 (18700)			1.32	I	4130 (18300)	30	<b>4B165</b>	11				
			1.36	I	6450 (28700)			1.36	I	6240 (27800)	30	<b>4C165</b>	11				
			1.89	II	6450 (28700)			1.89	II	6240 (27800)	30	<b>4C170</b>	11	(#)			
			2.05	III	6450 (28700)			2.05	III	6240 (27800)	30	<b>4C175</b>	11	(#)			
			1.89	II	10000 (44600)			1.89	II	9610 (42700)	30	<b>4D170</b>	11	(#)			
			2.05	III	10000 (44600)			2.05	III	9610 (42700)	30	<b>4D175</b>	11	(#)			
			2.43	III	9960 (44300)			2.43	III	9530 (42400)	30	<b>4D180</b>	11	(-),(#)			
2.73	III	9960 (44300)	2.73	III	9530 (42400)	30	<b>4D185</b>	11	(-),(#)								
113	15100 (1710)		1.15	I	4230 (18800)	137	12500 (1420)	1.15	I	4190 (18600)	30	<b>4B160</b>	13				
			1.32	I	4230 (18800)			1.32	I	4190 (18600)	30	<b>4B165</b>	13				
			1.36	I	6620 (29400)			1.36	I	6420 (28600)	30	<b>4C165</b>	13				
			1.89	II	6640 (29500)			1.89	II	6450 (28700)	30	<b>4C170</b>	13	(#)			
			2.05	III	6640 (29500)			2.05	III	6450 (28700)	30	<b>4C175</b>	13	(#)			
			1.89	II	10500 (46500)			1.89	II	10000 (44600)	30	<b>4D170</b>	13	(#)			
			2.05	III	10500 (46500)			2.05	III	10000 (44600)	30	<b>4D175</b>	13	(#)			
			2.43	III	10500 (46500)			2.43	III	10000 (44600)	30	<b>4D180</b>	13	(-),(#)			
2.73	III	10500 (46500)	2.73	III	10000 (44600)	30	<b>4D185</b>	13	(-),(#)								
104	16600 (1870)		1.15	I	4240 (18800)	125	13700 (1550)	1.15	I	4210 (18700)	30	<b>4B160</b>	14				
			1.27	I	4240 (18800)			1.32	I	4210 (18700)	30	<b>4B165</b>	14				
			1.36	I	6710 (29800)			1.36	I	6520 (29000)	30	<b>4C165</b>	14				
			1.89	II	6730 (29900)			1.89	II	6550 (29100)	30	<b>4C170</b>	14	(#)			
			2.05	III	6730 (29900)			2.05	III	6550 (29100)	30	<b>4C175</b>	14	(#)			
			1.89	II	10700 (47400)			1.89	II	10200 (45500)	30	<b>4D170</b>	14	(#)			
			2.05	III	10700 (47400)			2.05	III	10200 (45500)	30	<b>4D175</b>	14	(#)			
			2.43	III	10700 (47400)			2.43	III	10200 (45500)	30	<b>4D180</b>	14	(-),(#)			
2.73	III	10700 (47400)	2.73	III	10200 (45500)	30	<b>4D185</b>	14	(-),(#)								
90.6	18900 (2140)		1.14	I	4220 (18800)	109	15700 (1770)	1.15	I	4230 (18800)	30	<b>4B160</b>	16				
			1.14	I	4220 (18800)			1.20	I	4230 (18800)	30	<b>4B165</b>	16				
			1.15	I	6830 (30400)			1.15	I	6670 (29700)	30	<b>4C160</b>	16				
			1.36	I	6830 (30400)			1.36	I	6670 (29700)	30	<b>4C165</b>	16				
			1.89	II	6830 (30400)			1.89	II	6660 (29600)	30	<b>4C170</b>	16	(#)			
			2.01	III	6830 (30400)			2.05	III	6660 (29600)	30	<b>4C175</b>	16	(#)			
			1.89	II	10900 (48600)			1.89	II	10500 (46800)	30	<b>4D170</b>	16	(#)			
			2.05	III	10900 (48600)			2.05	III	10500 (46800)	30	<b>4D175</b>	16	(#)			
			2.43	III	10900 (48300)			2.43	III	10400 (46400)	30	<b>4D180</b>	16	(-),(#)			
			2.73	III	10900 (48300)			2.73	III	10400 (46400)	30	<b>4D185</b>	16	(-),(#)			

Notes: [1] For Y4 Double Reductions (4XXXDX) refer to the above table; for Y4 single reduction refer to tables on pages 2.91-2.130.

[2] Variable Frequency Drive (VFD) notes (see page 2.8 for Constant Torque Speed Ranges):

All 1HP+ motors require EP suffix in model number and can be used with a VFD, unless noted.

(-) = For Inverter Operation, starting condition may require ambient temperature of 5° C or higher.

(#) = Mounting positions Y2, F2, G2, K2, V2, W2 operation is limited to 75 %ED (duty cycle) for a 10 minute total cycle (7.5 minutes max. on time).

# Standard Mounting Selection Tables

**30 HP  
(22 kW)**

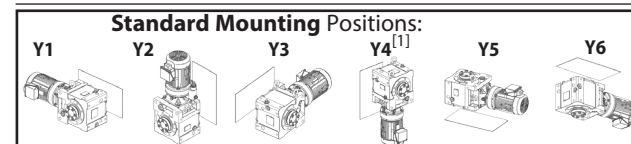

Dimension Pages:  
Single Reduction 2.132-2.143  
Single Reduction, Y2 2.144  
Double Reduction 2.146-2.161  
Double Reduction, Y2 2.162

Frequency	50 Hz	60 Hz
Input Speed	1450 RPM	1750 RPM
Number of Poles	4	

50Hz					60 Hz					Selection											
Output Speed (RPM)	Output Torque		Service Factor		Solid Shaft Overhung Load		Output Speed (RPM)	Output Torque		Service Factor		Solid Shaft Overhung Load		Base			VFD <sup>[2]</sup>				
	in-lbs	(N·m)	SF	AGMA Class	lbs	(N)		in-lbs	(N·m)	SF	AGMA Class	lbs	(N)	Motor Power Code	Frame Size	Ratio					
82.9	20700 (2340)		1.07	I	4200 (18700)	100.0	17100 (1940)	1.10	I	4230 (18800)	30	<b>4B160</b>	18								
			1.15	I	6900 (30700)			1.15	I	6750 (30000)	30	<b>4C160</b>	18								
			1.36	I	6900 (30700)			1.36	I	6750 (30000)	30	<b>4C165</b>	18								
			1.88	II	6890 (30700)			1.89	II	6750 (30000)	30	<b>4C170</b>	18	(#)							
			1.88	II	6890 (30700)			2.05	III	6750 (30000)	30	<b>4C175</b>	18	(#)							
			1.89	II	11100 (49500)			1.89	II	10700 (47700)	30	<b>4D170</b>	18	(#)							
			2.05	III	11100 (49500)			2.05	III	10700 (47700)	30	<b>4D175</b>	18	(#)							
			2.43	III	11100 (49200)			2.43	III	10600 (47300)	30	<b>4D180</b>	18	(-),(#)							
			2.73	III	11100 (49200)			2.73	III	10600 (47300)	30	<b>4D185</b>	18	(-),(#)							
			2.73	III	14800 (65800)			2.73	III	14200 (63000)	30	<b>4E185</b>	18	(-),(#)							
			69.0	24800 (2810)				1.15	I	6990 (31100)	83.3	20600 (2320)	1.15	I	6880 (30600)	30	<b>4C160</b>	21			
1.36	I	6990 (31100)				1.36	I	6880 (30600)	30	<b>4C165</b>			21								
1.54	II	6990 (31100)				1.54	II	6880 (30600)	30	<b>4C170</b>			21								
1.64	II	6990 (31100)				1.64	II	6880 (30600)	30	<b>4C175</b>			21								
1.68	II	11500 (51100)				1.68	II	11100 (49300)	30	<b>4D175</b>			21								
1.89	II	11500 (51100)				1.89	II	11100 (49300)	30	<b>4D180</b>			21	(-),(#)							
2.05	III	11500 (51100)				2.05	III	11100 (49300)	30	<b>4D185</b>			21	(-),(#)							
2.30	III	15500 (68900)				2.30	III	14900 (66100)	30	<b>4E190</b>			21	(-),(#)							
2.50	III	15500 (68900)				2.50	III	14900 (66100)	30	<b>4E195</b>			21	(-),(#)							
64.7	26500 (2990)					0.92	-	7020 (31200)	78.1	21900 (2480)			0.92	-	6920 (30800)	30	<b>4C160</b>	22			
						1.10	I	7020 (31200)					1.10	I	6920 (30800)	30	<b>4C165</b>	22			
			1.54	II	7020 (31200)	1.54	II	6920 (30800)			30	<b>4C170</b>	22								
			1.59	II	7020 (31200)	1.64	II	6920 (30800)			30	<b>4C175</b>	22								
			1.68	II	11600 (51700)	1.68	II	11200 (50000)			30	<b>4D175</b>	22								
			1.89	II	11600 (51700)	1.89	II	11200 (50000)			30	<b>4D180</b>	22	(-),(#)							
			2.05	III	11600 (51700)	2.05	III	11200 (50000)			30	<b>4D185</b>	22	(-),(#)							
			2.30	III	15700 (69900)	2.30	III	15100 (67000)			30	<b>4E190</b>	22	(-),(#)							
			2.50	III	15700 (69900)	2.50	III	15100 (67000)			30	<b>4E195</b>	22	(-),(#)							
			59.2	29000 (3270)		1.10	I	7040 (31300)			71.4	24000 (2710)	1.10	I	6980 (31000)	30	<b>4C165</b>	25			
						1.47	II	7040 (31300)					1.57	II	6980 (31000)	30	<b>4C175</b>	25			
1.68	II	11800 (52500)				1.68	II	11400 (50800)	30	<b>4D175</b>			25								
1.89	II	11800 (52500)				1.89	II	11400 (50800)	30	<b>4D180</b>			25	(-),(#)							
2.05	III	11800 (52500)				2.05	III	11400 (50800)	30	<b>4D185</b>			25	(-),(#)							
2.05	III	16000 (71200)				2.05	III	15400 (68400)	30	<b>4E185</b>			25	(-),(#)							
2.30	III	16000 (71200)				2.30	III	15400 (68400)	30	<b>4E190</b>			25	(-),(#)							
2.50	III	16000 (71200)				2.50	III	15400 (68400)	30	<b>4E195</b>			25	(-),(#)							

Notes: [1] For Y4 Double Reductions (4XXXDX) refer to the above table; for Y4 single reduction refer to tables on pages 2.91-2.130.

[2] Variable Frequency Drive (VFD) notes (see page 2.8 for Constant Torque Speed Ranges):

All 1HP+ motors require EP suffix in model number and can be used with a VFD, unless noted.

(-) = For Inverter Operation, starting condition may require ambient temperature of 5° C or higher.

(#) = Mounting positions Y2, F2, G2, K2, V2, W2 operation is limited to 75 %ED (duty cycle) for a 10 minute total cycle (7.5 minutes max. on time).

# Standard Mounting Selection Tables

**30 HP  
(22 kW)**

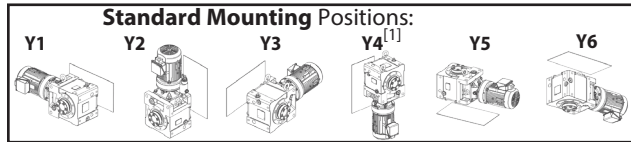

Dimension Pages:  
Single Reduction 2.132-2.143  
Single Reduction, Y2 2.144  
Double Reduction 2.146-2.161  
Double Reduction, Y2 2.162

Frequency	50 Hz	60 Hz
Input Speed	1450 RPM	1750 RPM
Number of Poles	4	

50Hz				60 Hz				Selection								
Output Speed (RPM)	Output Torque		Service Factor	Solid Shaft Overhung Load		Output Speed (RPM)	Output Torque		Service Factor	Solid Shaft Overhung Load		Base			VFD <sup>[2]</sup>	
	in-lbs	(N·m)		lbs	(N)		in-lbs	(N·m)		lbs	(N)	Motor Power Code	Frame Size	Ratio		
51.8	33100 (3740)		1.10	I	7050 (31400)	62.5	27400 (3100)		1.10	I	7030 (31300)	30	<b>4C165</b>	28		
			1.34	I	7050 (31400)				1.37	I	7030 (31300)	30	<b>4C170</b>	28		
			1.54	II	12000 (53600)				1.54	II	11700 (52000)	30	<b>4D170</b>	28		
			1.68	II	12000 (53600)				1.68	II	11700 (52000)	30	<b>4D175</b>	28		
			1.89	II	12000 (53600)				1.89	II	11700 (52000)	30	<b>4D180</b>	28		(-),(#)
			2.05	III	12000 (53600)				2.05	III	11700 (52000)	30	<b>4D185</b>	28		(-),(#)
			1.89	II	16400 (73200)				1.89	II	15800 (70400)	30	<b>4E180</b>	28		(-),(#)
			2.05	III	16400 (73200)				2.05	III	15800 (70400)	30	<b>4E185</b>	28		(-),(#)
			2.30	III	16400 (73200)				2.30	III	15800 (70400)	30	<b>4E190</b>	28		(-),(#)
			2.50	III	16400 (73200)				2.50	III	15800 (70400)	30	<b>4E195</b>	28		(-),(#)
2.50	III	29000 (129000)	2.50	III	27700 (123000)	30	<b>4F195</b>	28	(-),(#)							
41.2	41600 (4700)		1.09	I	6960 (31000)	49.7	34500 (3900)		1.09	I	7040 (31300)	30	<b>4C165</b>	35		
			1.25	I	12400 (55200)				1.25	I	12100 (53900)	30	<b>4D170</b>	35		
			1.37	I	12400 (55200)				1.37	I	12100 (53900)	30	<b>4D175</b>	35		
			1.81	II	12400 (55200)				1.89	II	12100 (53900)	30	<b>4D180</b>	35		(#)
			1.89	II	17200 (76300)				1.89	II	16600 (73700)	30	<b>4E180</b>	35		(#)
			2.05	III	17200 (76300)				2.05	III	16600 (73700)	30	<b>4E185</b>	35		(#)
			2.09	III	17200 (76300)				2.30	III	16600 (73700)	30	<b>4E190</b>	35		(-),(#)
			2.09	III	17200 (76300)				2.50	III	16600 (73700)	30	<b>4E195</b>	35		(-),(#)
			2.05	III	30400 (135000)				2.05	III	29300 (130000)	30	<b>4F185</b>	35		(#)
			2.30	III	30400 (135000)				2.30	III	29300 (130000)	30	<b>4F190</b>	35		(-),(#)
2.50	III	30400 (135000)	2.50	III	29300 (130000)	30	<b>4F195</b>	35	(-),(#)							
37.7	45500 (5140)		0.97	-	6900 (30700)	45.5	37700 (4260)		1.00	I	7020 (31200)	30	<b>4C165</b>	39		
			1.10	I	12500 (55700)				1.10	I	12300 (54500)	30	<b>4D165</b>	39		
			1.25	I	12500 (55700)				1.25	I	12300 (54500)	30	<b>4D170</b>	39		
			1.37	I	12500 (55700)				1.37	I	12300 (54500)	30	<b>4D175</b>	39		
			1.67	II	12500 (55700)				1.89	II	12300 (54500)	30	<b>4D180</b>	39		
			1.89	II	17400 (77500)				1.89	II	16900 (75000)	30	<b>4E180</b>	39		
			1.91	II	17400 (77500)				2.05	III	16900 (75000)	30	<b>4E185</b>	39		
			1.91	II	17400 (77500)				2.30	III	16900 (75000)	30	<b>4E190</b>	39		(-)
			1.91	II	17400 (77500)				2.31	III	16900 (75000)	30	<b>4E195</b>	39		(-)
			1.89	II	30200 (134000)				1.89	II	30000 (133000)	30	<b>4F180</b>	39		
			2.05	III	30200 (134000)				2.05	III	30000 (133000)	30	<b>4F185</b>	39		
			2.30	III	30200 (134000)				2.30	III	30000 (133000)	30	<b>4F190</b>	39		(-)
			2.50	III	30200 (134000)				2.50	III	30000 (133000)	30	<b>4F195</b>	39		(-)

# Standard Mounting Selection Tables

**30 HP  
(22 kW)**

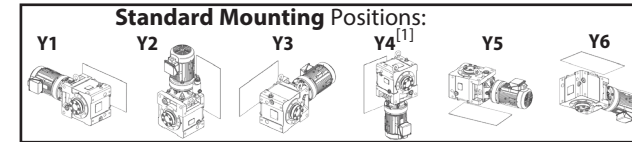

Dimension Pages:  
Single Reduction 2.132-2.143  
Single Reduction, Y2 2.144  
Double Reduction 2.146-2.161  
Double Reduction, Y2 2.162

Frequency	50 Hz	60 Hz
Input Speed	1450 RPM	1750 RPM
Number of Poles	4	

50Hz				60 Hz				Selection								
Output Speed (RPM)	Output Torque		Service Factor	Solid Shaft Overhung Load		Output Speed (RPM)	Output Torque		Service Factor	Solid Shaft Overhung Load		Base			VFD <sup>[2]</sup>	
	in-lbs	(N·m)		lbs	(N)		in-lbs	(N·m)		lbs	(N)	Motor Power Code	Frame Size	Ratio		
31.9	53800 (6080)		0.82	-	4520 (20100)	38.5	44600 (5040)		0.85	-	6920 (30800)	30	<b>4C160</b>	46		
			0.82	-	4520 (20100)				0.85	-	6920 (30800)	30	<b>4C165</b>	46		
			1.24	I	12700 (56400)				1.24	I	12500 (55600)	30	<b>4D170</b>	46		
			1.37	I	12700 (56400)				1.37	I	12500 (55600)	30	<b>4D175</b>	46		
			1.43	II	12700 (56400)				1.69	II	12500 (55600)	30	<b>4D180</b>	46		
			1.62	II	17900 (79600)				1.89	II	17400 (77200)	30	<b>4E180</b>	46		
			1.62	II	17900 (79600)				1.95	II	17400 (77200)	30	<b>4E185</b>	46		
			1.62	II	17900 (79600)				1.95	II	17400 (77200)	30	<b>4E190</b>	46		(-)
			1.62	II	17900 (79600)				1.95	II	17400 (77200)	30	<b>4E195</b>	46		(-)
			1.89	II	29800 (133000)				1.89	II	30200 (135000)	30	<b>4F180</b>	46		
			2.05	III	29800 (133000)				2.05	III	30200 (135000)	30	<b>4F185</b>	46		
			2.30	III	29800 (133000)				2.30	III	30200 (135000)	30	<b>4F190</b>	46		(-)
			2.50	III	29800 (133000)				2.50	III	30200 (135000)	30	<b>4F195</b>	46		(-)
27.6	62100 (7010)		1.02	I	12800 (56800)	33.3	51400 (5810)		1.03	I	12600 (56200)	30	<b>4D165</b>	53		
			1.16	I	12800 (56800)				1.16	I	12600 (56200)	30	<b>4D170</b>	53		
			1.24	I	12800 (56800)				1.24	I	12600 (56200)	30	<b>4D175</b>	53		
			1.24	I	12800 (56800)				1.47	II	12600 (56200)	30	<b>4D180</b>	53		
			1.37	I	18200 (81100)				1.37	I	17800 (79000)	30	<b>4E175</b>	53		
			1.40	II	18200 (81100)				1.47	II	17800 (79000)	30	<b>4E180</b>	53		
			1.40	II	18200 (81100)				1.69	II	17800 (79000)	30	<b>4E185</b>	53		
			1.40	II	18200 (81100)				1.69	II	17800 (79000)	30	<b>4E190</b>	53		(-)
			1.40	II	18200 (81100)				1.69	II	17800 (79000)	30	<b>4E195</b>	53		(-)
			1.47	II	29500 (131000)				1.47	II	29900 (133000)	30	<b>4F180</b>	53		
			1.77	II	29500 (131000)				1.77	II	29900 (133000)	30	<b>4F185</b>	53		
			2.30	III	29500 (131000)				2.30	III	29900 (133000)	30	<b>4F190</b>	53		(-)
			2.50	III	29500 (131000)				2.50	III	29900 (133000)	30	<b>4F195</b>	53		(-)
24.4	70400 (7950)		0.85	-	12800 (56800)	29.4	58300 (6590)		0.85	-	12700 (56700)	30	<b>4D165</b>	60		
			1.10	I	12800 (56800)				1.10	I	12700 (56700)	30	<b>4D175</b>	60		
			1.10	I	12800 (56800)				1.32	I	12700 (56700)	30	<b>4D180</b>	60		
			1.24	I	18500 (82300)				1.39	I	18100 (80500)	30	<b>4E180</b>	60		
			1.24	I	18500 (82300)				1.49	II	18100 (80500)	30	<b>4E185</b>	60		
			1.24	I	18500 (82300)				1.49	II	18100 (80500)	30	<b>4E190</b>	60		(-)
			1.24	I	18500 (82300)				1.49	II	18100 (80500)	30	<b>4E195</b>	60		(-)
			1.39	I	29100 (130000)				1.39	I	29600 (132000)	30	<b>4F180</b>	60		
			1.74	II	29100 (130000)				1.77	II	29600 (132000)	30	<b>4F185</b>	60		
			2.26	III	29100 (130000)				2.30	III	29600 (132000)	30	<b>4F190</b>	60		(-)
			2.26	III	29100 (130000)				2.50	III	29600 (132000)	30	<b>4F195</b>	60		(-)

Notes: [1] For Y4 Double Reductions (4XXXDX) refer to the above table; for Y4 single reduction refer to tables on pages 2.91-2.130.

[2] Variable Frequency Drive (VFD) notes (see page 2.8 for Constant Torque Speed Ranges):

All 1HP+ motors require EP suffix in model number and can be used with a VFD, unless noted.

(-) = For Inverter Operation, starting condition may require ambient temperature of 5° C or higher.

(#) = Mounting positions Y2, F2, G2, K2, V2, W2 operation is limited to 75 %ED (duty cycle) for a 10 minute total cycle (7.5 minutes max. on time).

Notes: [1] For Y4 Double Reductions (4XXXDX) refer to the above table; for Y4 single reduction refer to tables on pages 2.91-2.130.

[2] Variable Frequency Drive (VFD) notes (see page 2.8 for Constant Torque Speed Ranges):

All 1HP+ motors require EP suffix in model number and can be used with a VFD, unless noted.

(-) = For Inverter Operation, starting condition may require ambient temperature of 5° C or higher.

(#) = Mounting positions Y2, F2, G2, K2, V2, W2 operation is limited to 75 %ED (duty cycle) for a 10 minute total cycle (7.5 minutes max. on time).

# Standard Mounting Selection Tables

**30 HP  
(22 kW)**

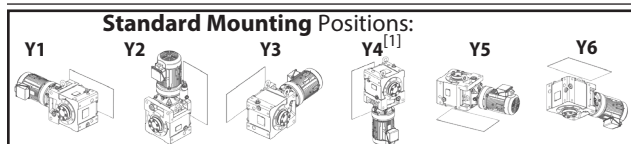

Dimension Pages:  
Single Reduction, Y2 2.132-2.143  
Single Reduction, Y2 2.144  
Double Reduction 2.146-2.161  
Double Reduction, Y2 2.162

Frequency	50 Hz	60 Hz
Input Speed	1450 RPM	1750 RPM
Number of Poles	4	

50Hz					60 Hz					Selection							
Output Speed (RPM)	Output Torque		Service Factor		Solid Shaft Overhung Load		Output Speed (RPM)	Output Torque		Service Factor		Solid Shaft Overhung Load		Base			VFD <sup>[2]</sup>
	in-lbs	(N·m)	SF	AGMA Class	lbs	(N)		in-lbs	(N·m)	SF	AGMA Class	lbs	(N)	Motor Power Code	Frame Size	Ratio	
21.6	79500 (8980)		0.97	-	10400 (46200)	26.0	65800 (7440)	0.97	-	12800 (56800)	30	<b>4D175</b>	67				
			0.97	-	10400 (46200)			1.17	I	12800 (56800)	30	<b>4D180</b>	67				
			1.07	I	18700 (83200)			1.09	I	18400 (81700)	30	<b>4E175</b>	67				
			1.09	I	18700 (83200)			1.32	I	18400 (81700)	30	<b>4E180</b>	67				
			1.09	I	18700 (83200)			1.32	I	18400 (81700)	30	<b>4E185</b>	67				
			1.09	I	18700 (83200)			1.32	I	18400 (81700)	30	<b>4E190</b>	67				
			1.09	I	18700 (83200)			1.32	I	18400 (81700)	30	<b>4E195</b>	67				
			1.36	I	28700 (128000)			1.36	I	29300 (130000)	30	<b>4F180</b>	67				
			1.73	II	28700 (128000)			1.77	II	29300 (130000)	30	<b>4F185</b>	67				
			1.86	II	28700 (128000)			1.86	II	29300 (130000)	30	<b>4F190</b>	67				
2.00	III	28700 (128000)	2.19	III	29300 (130000)	30	<b>4F195</b>	67									
19.7	86900 (9820)		0.89	-	5760 (25600)	23.8	72000 (8140)	0.89	-	12800 (56800)	30	<b>4D175</b>	74				
			0.89	-	5760 (25600)			1.07	I	12800 (56800)	30	<b>4D180</b>	74				
			1.00	I	18800 (83800)			1.00	I	18500 (82500)	30	<b>4E175</b>	74				
			1.00	I	18800 (83800)			1.21	I	18500 (82500)	30	<b>4E180</b>	74				
			1.00	I	18800 (83800)			1.21	I	18500 (82500)	30	<b>4E185</b>	74				
			1.00	I	18800 (83800)			1.21	I	18500 (82500)	30	<b>4E190</b>	74				
			1.00	I	18800 (83800)			1.21	I	18500 (82500)	30	<b>4E195</b>	74				
			1.36	I	28400 (126000)			1.36	I	29100 (129000)	30	<b>4F180</b>	74				
			1.73	II	28400 (126000)			1.77	II	29100 (129000)	30	<b>4F185</b>	74				
			1.83	II	28400 (126000)			1.86	II	29100 (129000)	30	<b>4F190</b>	74				
1.83	II	28400 (126000)	2.19	III	29100 (129000)	30	<b>4F195</b>	74									
18.1	94600 (10700)		0.82	-	-	21.9	78400 (8860)	0.98	-	10900 (48400)	30	<b>4D180</b>	80				
			0.89	-	18900 (84200)			0.89	-	18700 (83100)	30	<b>4E175</b>	80				
			0.92	-	18900 (84200)			1.10	I	18700 (83100)	30	<b>4E180</b>	80				
			0.92	-	18900 (84200)			1.11	I	18700 (83100)	30	<b>4E185</b>	80				
			0.92	-	18900 (84200)			1.11	I	18700 (83100)	30	<b>4E190</b>	80				
			0.92	-	18900 (84200)			1.11	I	18700 (83100)	30	<b>4E195</b>	80				
			1.10	I	28100 (125000)			1.10	I	28800 (128000)	30	<b>4F180</b>	80				
			1.37	I	28100 (125000)			1.37	I	28800 (128000)	30	<b>4F185</b>	80				
			1.60	II	28100 (125000)			1.60	II	28800 (128000)	30	<b>4F190</b>	80				
			1.68	II	28100 (125000)			1.84	II	28800 (128000)	30	<b>4F195</b>	80				

# Standard Mounting Selection Tables

**30 HP  
(22 kW)**

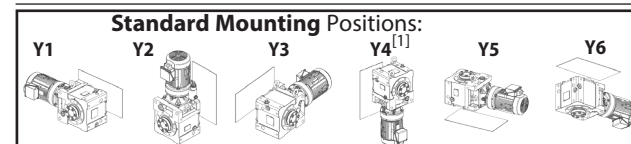

Dimension Pages:  
Single Reduction 2.132-2.143  
Single Reduction, Y2 2.144  
Double Reduction 2.146-2.161  
Double Reduction, Y2 2.162

Frequency	50 Hz	60 Hz
Input Speed	1450 RPM	1750 RPM
Number of Poles	4	

50Hz					60 Hz					Selection							
Output Speed (RPM)	Output Torque		Service Factor		Solid Shaft Overhung Load		Output Speed (RPM)	Output Torque		Service Factor		Solid Shaft Overhung Load		Base			VFD <sup>[2]</sup>
	in-lbs	(N·m)	SF	AGMA Class	lbs	(N)		in-lbs	(N·m)	SF	AGMA Class	lbs	(N)	Motor Power Code	Frame Size	Ratio	
16.6	103000 (11700)		0.84	-	18200 (81100)	20.0	85700 (9690)	0.84	-	18800 (83700)	30	<b>4E175</b>	88				
			0.84	-	18200 (81100)			1.01	I	18800 (83700)	30	<b>4E180</b>	88				
			0.84	-	18200 (81100)			1.01	I	18800 (83700)	30	<b>4E185</b>	88				
			0.84	-	18200 (81100)			1.01	I	18800 (83700)	30	<b>4E190</b>	88				
			0.84	-	18200 (81100)			1.01	I	18800 (83700)	30	<b>4E195</b>	88				
			1.10	I	27700 (123000)			1.10	I	28500 (127000)	30	<b>4F180</b>	88				
			1.37	I	27700 (123000)			1.37	I	28500 (127000)	30	<b>4F185</b>	88				
			1.54	II	27700 (123000)			1.60	II	28500 (127000)	30	<b>4F190</b>	88				
			1.54	II	27700 (123000)			1.84	II	28500 (127000)	30	<b>4F195</b>	88				
			14.3	120000 (13600)				0.89	-	27000 (120000)	17.2	99400 (11200)	0.89				-
1.10	I	27000 (120000)				1.10	I	27900 (124000)	30	<b>4F185</b>			102				
1.33	I	27000 (120000)				1.40	II	27900 (124000)	30	<b>4F190</b>			102				
1.33	I	27000 (120000)				1.60	II	27900 (124000)	30	<b>4F195</b>			102				
12.9	132000 (15000)		0.84	-	26400 (118000)	15.6	110000 (12400)	0.85	-	27400 (122000)	30	<b>4F180</b>	112				
			1.03	I	26400 (118000)			1.03	I	27400 (122000)	30	<b>4F185</b>	112				
			1.10	I	26400 (118000)			1.10	I	27400 (122000)	30	<b>4F190</b>	112				
			1.20	I	26400 (118000)			1.37	I	27400 (122000)	30	<b>4F195</b>	112				
			1.20	I	26400 (118000)			1.37	I	27400 (122000)	30	<b>4F195</b>	112				
11.8	145000 (16400)		0.84	-	25900 (115000)	14.3	120000 (13600)	0.85	-	27000 (120000)	30	<b>4F180</b>	123				
			1.03	I	25900 (115000)			1.03	I	27000 (120000)	30	<b>4F185</b>	123				
			1.10	I	25900 (115000)			1.10	I	27000 (120000)	30	<b>4F190</b>	123				
			1.10	I	25900 (115000)			1.33	I	27000 (120000)	30	<b>4F195</b>	123				
			1.10	I	25900 (115000)			1.33	I	27000 (120000)	30	<b>4F195</b>	123				
9.63	178000 (20100)		0.84	-	24500 (109000)	11.6	147000 (16700)	0.85	-	25800 (115000)	30	<b>4F185</b>	151				
			0.90	-	24500 (109000)			0.95	-	25800 (115000)	30	<b>4F190</b>	151				
			0.90	-	24500 (109000)			1.08	I	25800 (115000)	30	<b>4F195</b>	151				

Notes: [1] For Y4 Double Reductions (4XXXDX) refer to the above table; for Y4 single reduction refer to tables on pages 2.91-2.130.

[2] Variable Frequency Drive (VFD) notes (see page 2.8 for Constant Torque Speed Ranges):

All 1HP+ motors require EP suffix in model number and can be used with a VFD, unless noted.

Notes: [1] For Y4 Double Reductions (4XXXDX) refer to the above table; for Y4 single reduction refer to tables on pages 2.91-2.130..

[2] Variable Frequency Drive (VFD) notes (see page 2.8 for Constant Torque Speed Ranges):

All 1HP+ motors require EP suffix in model number and can be used with a VFD, unless noted.



# Standard Mounting Selection Tables

**40 HP  
(30 kW)**

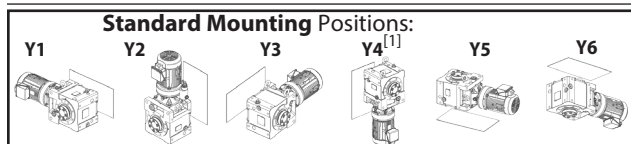

Dimension Pages:  
Single Reduction 2.132-2.143  
Single Reduction, Y2 2.144  
Double Reduction 2.146-2.161  
Double Reduction, Y2 2.162

Frequency	50 Hz	60 Hz
Input Speed	1450 RPM	1750 RPM
Number of Poles	4	

50Hz					60 Hz					Selection							
Output Speed (RPM)	Output Torque		Service Factor		Solid Shaft Overhung Load		Output Speed (RPM)	Output Torque		Service Factor		Solid Shaft Overhung Load		Base			VFD <sup>[2]</sup>
	in-lbs	(N·m)	SF	AGMA Class	lbs	(N)		in-lbs	(N·m)	SF	AGMA Class	lbs	(N)	Motor Power Code	Frame Size	Ratio	
138	16900 (1910)		1.38	I	6010 (26700)	167	14000 (1580)	1.38	I	5870 (26100)	40	<b>4C170</b>	11	(#)			
			1.50	II	6010 (26700)		1.50	II	5870 (26100)	40	<b>4C175</b>	11	(#)				
			1.38	I	9660 (43000)		1.38	I	9290 (41300)	40	<b>4D170</b>	11	(#)				
			1.50	II	9660 (43000)		1.50	II	9290 (41300)	40	<b>4D175</b>	11	(#)				
			1.78	II	9590 (42700)		1.78	II	9230 (41000)	40	<b>4D180</b>	11	(-),(#)				
			2.00	III	9590 (42700)		2.00	III	9230 (41000)	40	<b>4D185</b>	11	(-),(#)				
			2.28	III	12900 (57400)		2.28	III	12400 (54900)	40	<b>4E190</b>	11	(-),(#)				
			2.50	III	12900 (57400)		2.50	III	12400 (54900)	40	<b>4E195</b>	11	(-),(#)				
113	20600 (2330)		1.38	I	6110 (27200)	137	17100 (1930)	1.38	I	6010 (26700)	40	<b>4C170</b>	13	(#)			
			1.50	II	6110 (27200)		1.50	II	6010 (26700)	40	<b>4C175</b>	13	(#)				
			1.38	I	10000 (44500)		1.38	I	9660 (43000)	40	<b>4D170</b>	13	(#)				
			1.50	II	10000 (44500)		1.50	II	9660 (43000)	40	<b>4D175</b>	13	(#)				
			1.78	II	10000 (44500)		1.78	II	9660 (43000)	40	<b>4D180</b>	13	(-),(#)				
			2.00	III	10000 (44500)		2.00	III	9660 (43000)	40	<b>4D185</b>	13	(-),(#)				
			2.28	III	13500 (59900)		2.28	III	12900 (57400)	40	<b>4E190</b>	13	(-),(#)				
			2.50	III	13500 (59900)		2.50	III	12900 (57400)	40	<b>4E195</b>	13	(-),(#)				
104	22600 (2550)		1.38	I	6140 (27300)	125	18700 (2110)	1.38	I	6060 (27000)	40	<b>4C170</b>	14	(#)			
			1.50	II	6140 (27300)		1.50	II	6060 (27000)	40	<b>4C175</b>	14	(#)				
			1.38	I	10200 (45200)		1.38	I	9830 (43700)	40	<b>4D170</b>	14	(#)				
			1.50	II	10200 (45200)		1.50	II	9830 (43700)	40	<b>4D175</b>	14	(#)				
			1.78	II	10200 (45200)		1.78	II	9830 (43700)	40	<b>4D180</b>	14	(-),(#)				
			2.00	III	10200 (45200)		2.00	III	9830 (43700)	40	<b>4D185</b>	14	(-),(#)				
			2.28	III	13700 (61000)		2.28	III	13200 (58600)	40	<b>4E190</b>	14	(-),(#)				
			2.50	III	13700 (61000)		2.50	III	13200 (58600)	40	<b>4E195</b>	14	(-),(#)				
90.6	25800 (2910)		1.38	I	6170 (27400)	109	21400 (2420)	1.38	I	6120 (27200)	40	<b>4C170</b>	16	(#)			
			1.47	II	6170 (27400)		1.50	II	6120 (27200)	40	<b>4C175</b>	16	(#)				
			1.38	I	10400 (46100)		1.38	I	10000 (44700)	40	<b>4D170</b>	16	(#)				
			1.50	II	10400 (46100)		1.50	II	10000 (44700)	40	<b>4D175</b>	16	(#)				
			1.78	II	10300 (45900)		1.78	II	9990 (44400)	40	<b>4D180</b>	16	(-),(#)				
			2.00	III	10300 (45900)		2.00	III	9990 (44400)	40	<b>4D185</b>	16	(-),(#)				
			2.28	III	14000 (62100)		2.28	III	13400 (59700)	40	<b>4E190</b>	16	(-),(#)				
			2.50	III	14000 (62100)		2.50	III	13400 (59700)	40	<b>4E195</b>	16	(-),(#)				

Notes: [1] For Y4 Double Reductions (4XXXDX) refer to the above table; for Y4 single reduction refer to tables on pages 2.91-2.130.

[2] Variable Frequency Drive (VFD) notes (see page 2.8 for Constant Torque Speed Ranges):

All 1HP+ motors require EP suffix in model number and can be used with a VFD, unless noted.

(-) = For Inverter Operation, starting condition may require ambient temperature of 5° C or higher.

(#) = Mounting positions Y2, F2, G2, K2, V2, W2 operation is limited to 75 %ED (duty cycle) for a 10 minute total cycle (7.5 minutes max. on time).

# Standard Mounting Selection Tables

**40 HP  
(30 kW)**

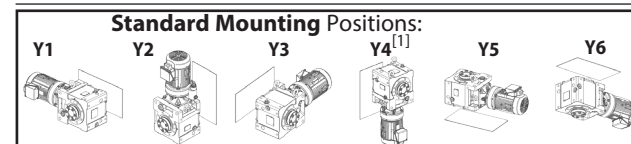

Dimension Pages:  
Single Reduction 2.132-2.143  
Single Reduction, Y2 2.144  
Double Reduction 2.146-2.161  
Double Reduction, Y2 2.162

Frequency	50 Hz	60 Hz
Input Speed	1450 RPM	1750 RPM
Number of Poles	4	

50Hz					60 Hz					Selection									
Output Speed (RPM)	Output Torque		Service Factor		Solid Shaft Overhung Load		Output Speed (RPM)	Output Torque		Service Factor		Solid Shaft Overhung Load		Base			VFD <sup>[2]</sup>		
	in-lbs	(N·m)	SF	AGMA Class	lbs	(N)		in-lbs	(N·m)	SF	AGMA Class	lbs	(N)	Motor Power Code	Frame Size	Ratio			
82.9	28200 (3190)		1.38	I	6170 (27500)	100.0	23400 (2640)	1.38	I	6150 (27400)	40	<b>4C170</b>	18	(#)					
			1.38	I	6170 (27500)		1.50	II	6150 (27400)	40	<b>4C175</b>	18	(#)						
			1.38	I	10500 (46800)		1.38	I	10200 (45400)	40	<b>4D170</b>	18	(#)						
			1.50	II	10500 (46800)		1.50	II	10200 (45400)	40	<b>4D175</b>	18	(#)						
			1.78	II	10500 (46600)		1.78	II	10100 (45100)	40	<b>4D180</b>	18	(-),(#)						
			2.00	III	10500 (46600)		2.00	III	10100 (45100)	40	<b>4D185</b>	18	(-),(#)						
			2.00	III	14300 (63400)		2.00	III	13700 (61000)	40	<b>4E185</b>	18	(-),(#)						
			2.28	III	14200 (63300)		2.28	III	13700 (60800)	40	<b>4E190</b>	18	(-),(#)						
69.0	33900 (3830)		1.23	I	10800 (47900)	83.3	28100 (3170)	1.23	I	10500 (46700)	40	<b>4D175</b>	21	(#)					
			1.38	I	10800 (47900)		1.38	I	10500 (46700)	40	<b>4D180</b>	21	(-),(#)						
			1.50	II	10800 (47900)		1.50	II	10500 (46700)	40	<b>4D185</b>	21	(-),(#)						
			1.69	II	14800 (66000)		1.69	II	14300 (63600)	40	<b>4E190</b>	21	(-),(#)						
			1.83	II	14800 (66000)		1.83	II	14300 (63600)	40	<b>4E195</b>	21	(-),(#)						
			64.7	36100 (4080)		1.13	I	6100 (27100)	78.1	29900 (3380)	1.13	I	6170 (27400)	40	<b>4C170</b>	22	(#)		
						1.17	I	6100 (27100)		1.20	I	6170 (27400)	40	<b>4C175</b>	22	(#)			
						1.23	I	10800 (48200)		1.23	I	10600 (47100)	40	<b>4D175</b>	22	(#)			
1.38	I	10800 (48200)					1.38	I	10600 (47100)	40	<b>4D180</b>	22	(-),(#)						
1.50	II	10800 (48200)					1.50	II	10600 (47100)	40	<b>4D185</b>	22	(-),(#)						
1.69	II	15000 (66700)					1.69	II	14500 (64400)	40	<b>4E190</b>	22	(-),(#)						
1.83	II	15000 (66700)					1.83	II	14500 (64400)	40	<b>4E195</b>	22	(-),(#)						
59.2	39500 (4460)					1.13	I	10900 (48700)	71.4	32700 (3700)	1.13	I	10700 (47700)	40	<b>4D170</b>	25	(#)		
			1.23	I	10900 (48700)		1.23	I	10700 (47700)	40	<b>4D175</b>	25	(#)						
			1.38	I	10900 (48700)		1.38	I	10700 (47700)	40	<b>4D180</b>	25	(-),(#)						
			1.50	II	10900 (48700)		1.50	II	10700 (47700)	40	<b>4D185</b>	25	(-),(#)						
			1.50	II	15200 (67800)		1.50	II	14700 (65600)	40	<b>4E185</b>	25	(-),(#)						
			1.69	II	15200 (67800)		1.69	II	14700 (65600)	40	<b>4E190</b>	25	(-),(#)						
			1.83	II	15200 (67800)		1.83	II	14700 (65600)	40	<b>4E195</b>	25	(-),(#)						

Notes: [1] For Y4 Double Reductions (4XXXDX) refer to the above table; for Y4 single reduction refer to tables on pages 2.91-2.130.

[2] Variable Frequency Drive (VFD) notes (see page 2.8 for Constant Torque Speed Ranges):

All 1HP+ motors require EP suffix in model number and can be used with a VFD, unless noted.

(-) = For Inverter Operation, starting condition may require ambient temperature of 5° C or higher.

(#) = Mounting positions Y2, F2, G2, K2, V2, W2 operation is limited to 75 %ED (duty cycle) for a 10 minute total cycle (7.5 minutes max. on time).

# Standard Mounting Selection Tables

**40 HP  
(30 kW)**

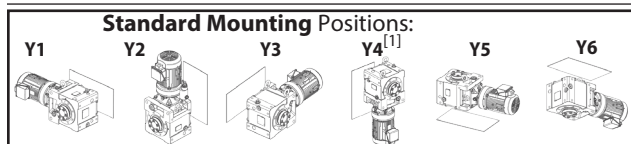

Dimension Pages:  
Single Reduction, Y2 2.132-2.143  
Single Reduction, Y2 2.144  
Double Reduction 2.146-2.161  
Double Reduction, Y2 2.162

Frequency	50 Hz	60 Hz
Input Speed	1450 RPM	1750 RPM
Number of Poles	4	

50Hz					60 Hz					Selection										
Output Speed (RPM)	Output Torque		Service Factor		Solid Shaft Overhung Load		Output Speed (RPM)	Output Torque		Service Factor		Solid Shaft Overhung Load		Base			VFD <sup>[2]</sup>			
	in-lbs	(N·m)	SF	AGMA Class	lbs	(N)		in-lbs	(N·m)	SF	AGMA Class	lbs	(N)	Motor Power Code	Frame Size	Ratio				
51.8	45100 (5100)		0.98	-	5910 (26300)	62.5	37400 (4230)		1.01	I	6080 (27100)	40	4C170	28						
			1.13	I	11100 (49300)				1.13	I	10900 (48400)						40	4D170	28	
			1.23	I	11100 (49300)				1.23	I	10900 (48400)						40	4D175	28	
			1.38	I	11100 (49300)				1.38	I	10900 (48400)						40	4D180	28	(-),(#)
			1.50	II	11100 (49300)				1.50	II	10900 (48400)						40	4D185	28	(-),(#)
			1.38	I	15600 (69200)				1.38	I	15100 (67100)						40	4E180	28	(-),(#)
			1.50	II	15600 (69200)				1.50	II	15100 (67100)						40	4E185	28	(-),(#)
			1.69	II	15600 (69200)				1.69	II	15100 (67100)						40	4E190	28	(-),(#)
			1.83	II	15600 (69200)				1.83	II	15100 (67100)						40	4E195	28	(-),(#)
			1.83	II	28300 (126000)				1.83	II	27000 (120000)						40	4F195	28	(-),(#)
41.2	56800 (6410)		1.00	I	11200 (49700)	49.7	47000 (5310)		1.00	I	11100 (49400)	40	4D175	35						
			1.33	I	11200 (49700)				1.38	I	11100 (49400)						40	4D180	35	(#)
			1.38	I	16000 (71400)				1.38	I	15700 (69600)						40	4E180	35	(#)
			1.50	II	16000 (71400)				1.50	II	15700 (69600)						40	4E185	35	(#)
			1.53	II	16000 (71400)				1.69	II	15700 (69600)						40	4E190	35	(-),(#)
			1.53	II	16000 (71400)				1.83	II	15700 (69600)						40	4E195	35	(-),(#)
			1.50	II	29700 (132000)				1.50	II	28500 (127000)						40	4F185	35	(#)
			1.69	II	29700 (132000)				1.69	II	28500 (127000)						40	4F190	35	(-),(#)
			1.83	II	29700 (132000)				1.83	II	28500 (127000)						40	4F195	35	(-),(#)
			37.7	62100 (7010)					1.00	I	11200 (49800)						45.5	51400 (5810)		1.00
1.22	I	11200 (49800)				1.38	I	11200 (49600)	40	4D180	39									
1.38	I	16200 (72100)				1.38	I	15900 (70500)	40	4E180	39									
1.40	II	16200 (72100)				1.50	II	15900 (70500)	40	4E185	39									
1.40	II	16200 (72100)				1.69	II	15900 (70500)	40	4E190	39	(-)								
1.40	II	16200 (72100)				1.69	II	15900 (70500)	40	4E195	39	(-)								
1.38	I	29500 (131000)				1.38	I	29100 (129000)	40	4F180	39									
1.50	II	29500 (131000)				1.50	II	29100 (129000)	40	4F185	39									
1.69	II	29500 (131000)				1.69	II	29100 (129000)	40	4F190	39	(-)								
1.83	II	29500 (131000)				1.83	II	29100 (129000)	40	4F195	39	(-)								

# Standard Mounting Selection Tables

**40 HP  
(30 kW)**

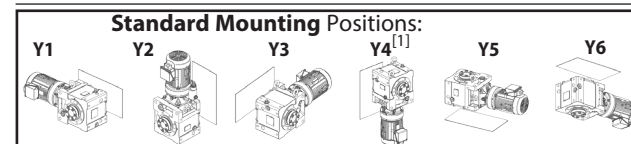

Dimension Pages:  
Single Reduction 2.132-2.143  
Single Reduction, Y2 2.144  
Double Reduction 2.146-2.161  
Double Reduction, Y2 2.162

Frequency	50 Hz	60 Hz
Input Speed	1450 RPM	1750 RPM
Number of Poles	4	

50Hz					60 Hz					Selection										
Output Speed (RPM)	Output Torque		Service Factor		Solid Shaft Overhung Load		Output Speed (RPM)	Output Torque		Service Factor		Solid Shaft Overhung Load		Base			VFD <sup>[2]</sup>			
	in-lbs	(N·m)	SF	AGMA Class	lbs	(N)		in-lbs	(N·m)	SF	AGMA Class	lbs	(N)	Motor Power Code	Frame Size	Ratio				
31.9	73400 (8290)		1.00	I	11100 (49400)	38.5	60800 (6870)		1.00	I	11200 (49800)	40	4D175	46						
			1.05	I	11100 (49400)				1.24	I	11200 (49800)						40	4D180	46	
			1.19	I	16500 (73200)				1.38	I	16200 (72000)						40	4E180	46	
			1.19	I	16500 (73200)				1.43	II	16200 (72000)						40	4E185	46	
			1.19	I	16500 (73200)				1.43	II	16200 (72000)						40	4E190	46	(-)
			1.19	I	16500 (73200)				1.43	II	16200 (72000)						40	4E195	46	(-)
			1.38	I	29000 (129000)				1.38	I	29500 (131000)						40	4F180	46	
			1.50	II	29000 (129000)				1.50	II	29500 (131000)						40	4F185	46	
			1.69	II	29000 (129000)				1.69	II	29500 (131000)						40	4F190	46	(-)
			1.83	II	29000 (129000)				1.83	II	29500 (131000)						40	4F195	46	(-)
27.6	84700 (9560)		0.91	-	7520 (33500)	33.3	70100 (7920)		0.91	-	11100 (49600)	40	4D175	53						
			0.91	-	7520 (33500)				1.08	I	11100 (49600)						40	4D180	53	
			1.00	I	16600 (73800)				1.00	I	16400 (72900)						40	4E175	53	
			1.03	I	16600 (73800)				1.08	I	16400 (72900)						40	4E180	53	
			1.03	I	16600 (73800)				1.24	I	16400 (72900)						40	4E185	53	
			1.03	I	16600 (73800)				1.24	I	16400 (72900)						40	4E190	53	(-)
			1.03	I	16600 (73800)				1.24	I	16400 (72900)						40	4E195	53	(-)
			1.08	I	28500 (127000)				1.08	I	29100 (130000)						40	4F180	53	
			1.30	I	28500 (127000)				1.30	I	29100 (130000)						40	4F185	53	
			1.69	II	28500 (127000)				1.69	II	29100 (130000)						40	4F190	53	(-)
1.83	II	28500 (127000)	1.83	II	29100 (130000)	40	4F195	53	(-)											
24.4	95900 (10800)		0.80	-	16600 (74000)	29.4	79500 (8980)		0.80	-	16500 (73600)	40	4E175	60						
			0.91	-	16600 (74000)				1.02	I	16500 (73600)						40	4E180	60	
			0.91	-	16600 (74000)				1.09	I	16500 (73600)						40	4E185	60	
			0.91	-	16600 (74000)				1.09	I	16500 (73600)						40	4E190	60	(-)
			0.91	-	16600 (74000)				1.09	I	16500 (73600)						40	4E195	60	(-)
			1.02	I	28000 (125000)				1.02	I	28700 (128000)						40	4F180	60	
			1.27	I	28000 (125000)				1.30	I	28700 (128000)						40	4F185	60	
			1.66	II	28000 (125000)				1.69	II	28700 (128000)						40	4F190	60	(-)
			1.66	II	28000 (125000)				1.83	II	28700 (128000)						40	4F195	60	(-)
			21.6	108000 (12200)					0.80	-	16600 (73800)						26.0	89800 (10100)		0.97
0.80	-	16600 (73800)				0.97	-	16600 (73900)	40	4E185	67									
0.80	-	16600 (73800)				0.97	-	16600 (73900)	40	4E190	67									
0.80	-	16600 (73800)				0.97	-	16600 (73900)	40	4E195	67									
1.00	I	27500 (122000)				1.00	I	28300 (126000)	40	4F180	67									
1.27	I	27500 (122000)				1.30	I	28300 (126000)	40	4F185	67									
1.37	I	27500 (122000)				1.37	I	28300 (126000)	40	4F190	67									
1.47	II	27500 (122000)				1.60	II	28300 (126000)	40	4F195	67									

Notes: [1] For Y4 Double Reductions (4XXXDX) refer to the above table; for Y4 single reduction refer to tables on pages 2.91-2.130.

[2] Variable Frequency Drive (VFD) notes (see page 2.8 for Constant Torque Speed Ranges):

All 1HP+ motors require EP suffix in model number and can be used with a VFD, unless noted.

(-) = For Inverter Operation, starting condition may require ambient temperature of 5° C or higher.

(#) = Mounting positions Y2, F2, G2, K2, V2, W2 operation is limited to 75 %ED (duty cycle) for a 10 minute total cycle (7.5 minutes max. on time).

Notes: [1] For Y4 Double Reductions (4XXXDX) refer to the above table; for Y4 single reduction refer to tables on pages 2.91-2.130.

[2] Variable Frequency Drive (VFD) notes (see page 2.8 for Constant Torque Speed Ranges):

All 1HP+ motors require EP suffix in model number and can be used with a VFD, unless noted.

(-) = For Inverter Operation, starting condition may require ambient temperature of 5° C or higher.

# Standard Mounting Selection Tables

**40 HP  
(30 kW)**

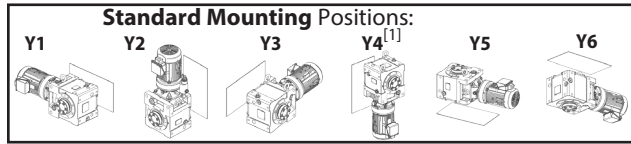

Dimension Pages:  
Single Reduction 2.132-2.143  
Single Reduction, Y2 2.144  
Double Reduction 2.146-2.161  
Double Reduction, Y2 2.162

Frequency	50 Hz	60 Hz
Input Speed	1450 RPM	1750 RPM
Number of Poles	4	

50Hz				60 Hz				Selection							
Output Speed (RPM)	Output Torque		Service Factor	Solid Shaft Overhung Load		Output Speed (RPM)	Output Torque		Service Factor	Solid Shaft Overhung Load		Base			VFD <sup>[2]</sup>
	in-lbs	(N·m)		lbs	(N)		in-lbs	(N·m)		lbs	(N)	Motor Power Code	Frame Size	Ratio	
19.7	119000 (13400)		1.00	I	27000 (120000)	23.8	98200 (11100)		1.00	I	27900 (124000)	40	4F180	74	
			1.27	I	27000 (120000)				1.30	I	27900 (124000)				
			1.34	I	27000 (120000)				1.37	I	27900 (124000)				
			1.34	I	27000 (120000)				1.60	II	27900 (124000)				
18.1	129000 (14600)		0.80	-	26600 (118000)	21.9	107000 (12100)		0.80	-	27500 (123000)	40	4F180	80	
			1.00	I	26600 (118000)				1.00	I	27500 (123000)				
			1.17	I	26600 (118000)				1.17	I	27500 (123000)				
			1.24	I	26600 (118000)				1.35	I	27500 (123000)				
16.6	141000 (15900)		0.80	-	26100 (116000)	20.0	117000 (13200)		0.80	-	27100 (121000)	40	4F180	88	
			1.00	I	26100 (116000)				1.00	I	27100 (121000)				
			1.13	I	26100 (116000)				1.17	I	27100 (121000)				
			1.13	I	26100 (116000)				1.35	I	27100 (121000)				
14.3	164000 (18500)		0.80	-	25100 (112000)	17.2	136000 (15300)		0.80	-	26300 (117000)	40	4F185	102	
			0.97	-	25100 (112000)				1.02	I	26300 (117000)				
			0.97	-	25100 (112000)				1.17	I	26300 (117000)				
12.9	181000 (20400)		0.81	-	24400 (108000)	15.6	150000 (16900)		0.81	-	25700 (114000)	40	4F190	112	
			0.88	-	24400 (108000)				1.00	I	25700 (114000)				

# Standard Mounting Selection Tables

**50 HP  
(37 kW)**

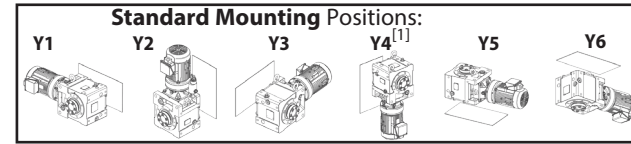

Dimension Pages:  
Single Reduction 2.132-2.143  
Single Reduction, Y2 2.144  
Double Reduction 2.146-2.161  
Double Reduction, Y2 2.162

Frequency	50 Hz	60 Hz
Input Speed	1450 RPM	1750 RPM
Number of Poles	4	

50Hz				60 Hz				Selection							
Output Speed (RPM)	Output Torque		Service Factor	Solid Shaft Overhung Load		Output Speed (RPM)	Output Torque		Service Factor	Solid Shaft Overhung Load		Base			VFD <sup>[2]</sup>
	in-lbs	(N·m)		lbs	(N)		in-lbs	(N·m)		lbs	(N)	Motor Power Code	Frame Size	Ratio	
138	20900 (2360)		1.44	II	9280 (41300)	167	17300 (1950)		1.44	II	8960 (39900)	50	4D180	11	(-),(#)
			1.62	II	9280 (41300)				1.62	II	8960 (39900)				
			1.85	II	12600 (56100)				1.85	II	12100 (53800)				
			2.03	III	12600 (56100)				2.03	III	12100 (53800)				
			1.44	II	9610 (42700)				1.44	II	9330 (41500)				
113	25500 (2880)		1.44	II	9610 (42700)	137	21100 (2380)		1.44	II	9330 (41500)	50	4D180	13	(-),(#)
			1.62	II	9610 (42700)				1.62	II	9330 (41500)				
			1.85	II	13100 (58300)				1.85	II	12600 (56100)				
			2.03	III	13100 (58300)				2.03	III	12600 (56100)				
104	27800 (3150)		1.44	II	9730 (43300)	125	23100 (2610)		1.44	II	9470 (42100)	50	4D180	14	(-),(#)
			1.62	II	9730 (43300)				1.62	II	9470 (42100)				
			1.85	II	13300 (59300)				1.85	II	12800 (57100)				
			2.03	III	13300 (59300)				2.03	III	12800 (57100)				
90.6	31800 (3590)		1.44	II	9840 (43800)	109	26400 (2980)		1.44	II	9600 (42700)	50	4D180	16	(-),(#)
			1.62	II	9840 (43800)				1.62	II	9600 (42700)				
			1.85	II	13500 (60200)				1.85	II	13100 (58100)				
			2.03	III	13500 (60200)				2.03	III	13100 (58100)				
			1.44	II	9950 (44200)				1.44	II	9720 (43200)				
82.9	34800 (3930)		1.44	II	9950 (44200)	100.0	28800 (3260)		1.44	II	9720 (43200)	50	4D180	18	(-),(#)
			1.62	II	9950 (44200)				1.62	II	9720 (43200)				
			1.62	II	13800 (61300)				1.62	II	13300 (59200)				
			1.85	II	13800 (61200)				1.85	II	13300 (59100)				
			2.03	III	13800 (61200)				2.03	III	13300 (59100)				
69.0	41800 (4720)		1.12	I	10100 (45100)	83.3	34600 (3910)		1.12	I	9970 (44300)	50	4D180	21	(-),(#)
			1.22	I	10100 (45100)				1.22	I	9970 (44300)				
			1.37	I	14300 (63400)				1.37	I	13800 (61500)				
			1.49	II	14300 (63400)				1.49	II	13800 (61500)				
			1.12	I	10200 (45200)				1.12	I	10000 (44600)				
64.7	44500 (5030)		1.12	I	10200 (45200)	78.1	36900 (4170)		1.12	I	10000 (44600)	50	4D180	22	(-),(#)
			1.22	I	10200 (45200)				1.22	I	10000 (44600)				
			1.37	I	14400 (64000)				1.37	I	14000 (62200)				
			1.49	II	14400 (64000)				1.49	II	14000 (62200)				
59.2	48700 (5500)		1.12	I	10200 (45400)	71.4	40400 (4560)		1.12	I	10100 (45000)	50	4D180	25	(-),(#)
			1.22	I	10200 (45400)				1.22	I	10100 (45000)				
			1.22	I	14600 (64800)				1.22	I	14200 (63100)				
			1.37	I	14600 (64800)				1.37	I	14200 (63100)				

Notes: [1] For Y4 Double Reductions (4XXXDX) refer to the above table; for Y4 single reduction refer to tables on pages 2.91-2.130.

[2] Variable Frequency Drive (VFD) notes (see page 2.8 for Constant Torque Speed Ranges):  
All 1HP+ motors require EP suffix in model number and can be used with a VFD, unless noted.

Notes: [1] For Y4 Double Reductions (4XXXDX) refer to the above table; for Y4 single reduction refer to tables on pages 2.91-2.130..

[2] Variable Frequency Drive (VFD) notes (see page 2.8 for Constant Torque Speed Ranges):  
All 1HP+ motors require EP suffix in model number and can be used with a VFD, unless noted.  
(-) = For Inverter Operation, starting condition may require ambient temperature of 5° C or higher.  
(#) = Mounting positions Y2, F2, G2, K2, V2, W2 operation is limited to 75 %ED (duty cycle) for a 10 minute total cycle (7.5 minutes max. on time).

# Standard Mounting Selection Tables

**50 HP  
(37 kW)**

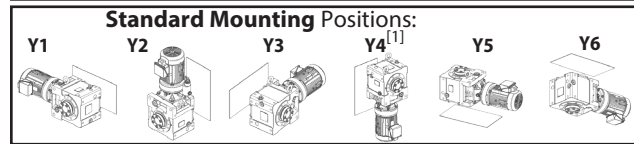

Dimension Pages:  
Single Reduction 2.132-2.143  
Single Reduction, Y2 2.144  
Double Reduction 2.146-2.161  
Double Reduction, Y2 2.162

Frequency	50 Hz	60 Hz
Input Speed	1450 RPM	1750 RPM
Number of Poles	4	

50Hz					60 Hz					Selection							
Output Speed (RPM)	Output Torque		Service Factor		Solid Shaft Overhung Load		Output Speed (RPM)	Output Torque		Service Factor		Solid Shaft Overhung Load		Base			VFD <sup>[2]</sup>
	in-lbs	(N·m)	SF	AGMA Class	lbs	(N)		in-lbs	(N·m)	SF	AGMA Class	lbs	(N)	Motor Power Code	Frame Size	Ratio	
51.8	55700 (6290)		1.12	I	10200 (45300)	62.5	46100 (5210)	1.12	I	10200 (45300)	50	<b>4D180</b>	28	(-),(#)			
			1.22	I	10200 (45300)			50	<b>4D185</b>	28	(-),(#)						
			1.12	I	14800 (65800)			50	<b>4E180</b>	28	(-),(#)						
			1.22	I	14800 (65800)			50	<b>4E185</b>	28	(-),(#)						
			1.37	I	14800 (65800)			50	<b>4E190</b>	28	(-),(#)						
			1.49	II	14800 (65800)			50	<b>4E195</b>	28	(-),(#)						
			1.49	II	27600 (123000)			50	<b>4F195</b>	28	(-),(#)						
41.2	70000 (7910)		1.08	I	10100 (45000)	49.7	58000 (6550)	1.12	I	10200 (45400)	50	<b>4D180</b>	35	(#)			
			1.12	I	15100 (67100)			50	<b>4E180</b>	35	(#)						
			1.22	I	15100 (67100)			50	<b>4E185</b>	35	(#)						
			1.24	I	15100 (67100)			50	<b>4E190</b>	35	(-),(#)						
			1.24	I	15100 (67100)			50	<b>4E195</b>	35	(-),(#)						
			1.22	I	28800 (128000)			50	<b>4F185</b>	35	(#)						
			1.37	I	28800 (128000)			50	<b>4F190</b>	35	(-),(#)						
1.49	II	28800 (128000)	50	<b>4F195</b>	35	(-),(#)											
37.7	76600 (8650)		0.99	-	10000 (44600)	45.5	63400 (7170)	1.12	I	10200 (45300)	50	<b>4D180</b>	39				
			1.12	I	15200 (67400)			50	<b>4E180</b>	39							
			1.14	I	15200 (67400)			50	<b>4E185</b>	39							
			1.14	I	15200 (67400)			50	<b>4E190</b>	39	(-)						
			1.14	I	15200 (67400)			50	<b>4E195</b>	39	(-)						
			1.12	I	28900 (128000)			50	<b>4F180</b>	39							
			1.22	I	28900 (128000)			50	<b>4F185</b>	39							
1.37	I	28900 (128000)	50	<b>4F190</b>	39	(-)											
1.49	II	28900 (128000)	50	<b>4F195</b>	39	(-)											
31.9	90500 (10200)		0.96	-	15200 (67600)	38.5	75000 (8470)	1.12	I	15100 (67300)	50	<b>4E180</b>	46				
			0.96	-	15200 (67600)			50	<b>4E185</b>	46							
			0.96	-	15200 (67600)			50	<b>4E190</b>	46	(-)						
			0.96	-	15200 (67600)			50	<b>4E195</b>	46	(-)						
			1.12	I	28300 (126000)			50	<b>4F180</b>	46							
			1.22	I	28300 (126000)			50	<b>4F185</b>	46							
			1.37	I	28300 (126000)			50	<b>4F190</b>	46	(-)						
1.49	II	28300 (126000)	50	<b>4F195</b>	46	(-)											

Notes: [1] For Y4 Double Reductions (4XXXDX) refer to the above table; for Y4 single reduction refer to tables on pages 2.91-2.130.

[2] Variable Frequency Drive (VFD) notes (see page 2.8 for Constant Torque Speed Ranges):

All 1HP+ motors require EP suffix in model number and can be used with a VFD, unless noted.

(-) = For Inverter Operation, starting condition may require ambient temperature of 5° C or higher.

(#) = Mounting positions Y2, F2, G2, K2, V2, W2 operation is limited to 75 %ED (duty cycle) for a 10 minute total cycle (7.5 minutes max. on time).

# Standard Mounting Selection Tables

**50 HP  
(37 kW)**

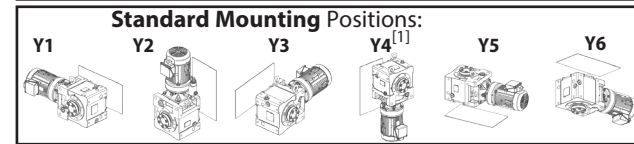

Dimension Pages:  
Single Reduction 2.132-2.143  
Single Reduction, Y2 2.144  
Double Reduction 2.146-2.161  
Double Reduction, Y2 2.162

Frequency	50 Hz	60 Hz
Input Speed	1450 RPM	1750 RPM
Number of Poles	4	

50Hz					60 Hz					Selection							
Output Speed (RPM)	Output Torque		Service Factor		Solid Shaft Overhung Load		Output Speed (RPM)	Output Torque		Service Factor		Solid Shaft Overhung Load		Base			VFD <sup>[2]</sup>
	in-lbs	(N·m)	SF	AGMA Class	lbs	(N)		in-lbs	(N·m)	SF	AGMA Class	lbs	(N)	Motor Power Code	Frame Size	Ratio	
27.6	104000 (11800)		0.83	-	15100 (67300)	33.3	86500 (9770)	0.88	-	15200 (67600)	50	<b>4E180</b>	53				
			0.83	-	15100 (67300)			50	<b>4E185</b>	53							
			0.83	-	15100 (67300)			50	<b>4E190</b>	53	(-)						
			0.83	-	15100 (67300)			50	<b>4E195</b>	53	(-)						
			0.88	-	27700 (123000)			50	<b>4F180</b>	53							
			1.05	I	27700 (123000)			50	<b>4F185</b>	53							
			1.37	I	27700 (123000)			50	<b>4F190</b>	53	(-)						
1.49	II	27700 (123000)	50	<b>4F195</b>	53	(-)											
24.4	118000 (13400)		0.83	-	27100 (120000)	29.4	98000 (11100)	0.83	-	27900 (124000)	50	<b>4F180</b>	60				
			1.03	I	27100 (120000)			50	<b>4F185</b>	60							
			1.35	I	27100 (120000)			50	<b>4F190</b>	60	(-)						
			1.35	I	27100 (120000)			50	<b>4F195</b>	60	(-)						
21.6	134000 (15100)		0.81	-	26400 (117000)	26.0	111000 (12500)	0.81	-	27400 (122000)	50	<b>4F180</b>	67				
			1.03	I	26400 (117000)			50	<b>4F185</b>	67							
			1.11	I	26400 (117000)			50	<b>4F190</b>	67							
			1.19	I	26400 (117000)			50	<b>4F195</b>	67							
19.7	146000 (16500)		0.81	-	25900 (115000)	23.8	121000 (13700)	0.81	-	26900 (120000)	50	<b>4F180</b>	74				
			1.03	I	25900 (115000)			50	<b>4F185</b>	74							
			1.09	I	25900 (115000)			50	<b>4F190</b>	74							
			1.09	I	25900 (115000)			50	<b>4F195</b>	74							
18.1	159000 (18000)		0.81	-	25300 (113000)	21.9	132000 (14900)	0.81	-	26500 (118000)	50	<b>4F185</b>	80				
			0.95	-	25300 (113000)			50	<b>4F190</b>	80							
			1.00	I	25300 (113000)			50	<b>4F195</b>	80							
16.6	174000 (19700)		0.81	-	24600 (110000)	20.0	144000 (16300)	0.81	-	25900 (115000)	50	<b>4F185</b>	88				
			0.92	-	24600 (110000)			50	<b>4F190</b>	88							
			0.92	-	24600 (110000)			50	<b>4F195</b>	88							

Notes: [1] For Y4 Double Reductions (4XXXDX) refer to the above table; for Y4 single reduction refer to tables on pages 2.91-2.130.

[2] Variable Frequency Drive (VFD) notes (see page 2.8 for Constant Torque Speed Ranges):

All 1HP+ motors require EP suffix in model number and can be used with a VFD, unless noted.

(-) = For Inverter Operation, starting condition may require ambient temperature of 5° C or higher.



# Standard Mounting Selection Tables

**60 HP  
(45 kW)**

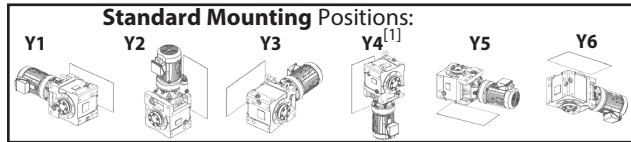

Dimension Pages:  
Single Reduction 2.132-2.143  
Single Reduction, Y2 2.144  
Double Reduction 2.146-2.161  
Double Reduction, Y2 2.162

Frequency	50 Hz	60 Hz
Input Speed	1450 RPM	1750 RPM
Number of Poles	4	

50Hz					60 Hz					Selection							
Output Speed (RPM)	Output Torque		Service Factor		Solid Shaft Overhung Load		Output Speed (RPM)	Output Torque		Service Factor		Solid Shaft Overhung Load		Base			VFD <sup>[2]</sup>
	in-lbs	(N·m)	SF	AGMA Class	lbs	(N)		in-lbs	(N·m)	SF	AGMA Class	lbs	(N)	Motor Power Code	Frame Size	Ratio	
138	25400 (2870)		1.52	II	12300 (54600)		167	21000 (2380)		1.52	II	11800 (52600)		60	<b>4E190</b>	11	(#)
			1.67	II	12300 (54600)					1.67	II	11800 (52600)		60	<b>4E195</b>	11	(#)
113	31000 (3500)		1.52	II	12700 (56400)		137	25700 (2900)		1.52	II	12300 (54500)		60	<b>4E190</b>	13	(#)
			1.67	II	12700 (56400)					1.67	II	12300 (54500)		60	<b>4E195</b>	13	(#)
104	33900 (3830)		1.52	II	12900 (57300)		125	28100 (3170)		1.52	II	12500 (55500)		60	<b>4E190</b>	14	(#)
			1.67	II	12900 (57300)					1.67	II	12500 (55500)		60	<b>4E195</b>	14	(#)
90.6	38700 (4370)		1.52	II	13000 (58000)		109	32100 (3620)		1.52	II	12700 (56300)		60	<b>4E190</b>	16	(#)
			1.67	II	13000 (58000)					1.67	II	12700 (56300)		60	<b>4E195</b>	16	(#)
82.9	42300 (4780)		1.52	II	13200 (58800)		100.0	35100 (3960)		1.52	II	12800 (57200)		60	<b>4E190</b>	18	(#)
			1.67	II	13200 (58800)					1.67	II	12800 (57200)		60	<b>4E195</b>	18	(#)
			1.67	II	24100 (107000)					1.67	II	23100 (103000)		60	<b>4F195</b>	18	(#)
69.0	50800 (5740)		1.12	I	13600 (60400)		83.3	42100 (4750)		1.12	I	13300 (59100)		60	<b>4E190</b>	21	(#)
			1.22	I	13600 (60400)					1.22	I	13300 (59100)		60	<b>4E195</b>	21	(#)
64.7	54200 (6120)		1.12	I	13700 (60800)		78.1	44900 (5070)		1.12	I	13400 (59600)		60	<b>4E190</b>	22	(#)
			1.22	I	13700 (60800)					1.22	I	13400 (59600)		60	<b>4E195</b>	22	(#)
59.2	59300 (6690)		1.12	I	13800 (61300)		71.4	49100 (5550)		1.12	I	13500 (60200)		60	<b>4E190</b>	25	(#)
			1.22	I	13800 (61300)					1.22	I	13500 (60200)		60	<b>4E195</b>	25	(#)
51.8	67700 (7650)		1.12	I	13900 (61900)		62.5	56100 (6340)		1.12	I	13700 (61000)		60	<b>4E190</b>	28	(#)
			1.22	I	13900 (61900)					1.22	I	13700 (61000)		60	<b>4E195</b>	28	(#)
			1.22	I	26800 (119000)					1.22	I	25800 (115000)		60	<b>4F195</b>	28	(#)
41.2	85100 (9620)		1.02	I	14000 (62100)		49.7	70500 (7970)		1.12	I	13900 (62000)		60	<b>4E190</b>	35	(#)
			1.02	I	14000 (62100)					1.22	I	13900 (62000)		60	<b>4E195</b>	35	(#)
			1.12	I	27800 (124000)					1.12	I	26900 (120000)		60	<b>4F190</b>	35	(#)
			1.22	I	27800 (124000)					1.22	I	26900 (120000)		60	<b>4F195</b>	35	(#)
37.7	93100 (10500)		0.93	-	13900 (62000)		45.5	77200 (8720)		1.12	I	14000 (62100)		60	<b>4E190</b>	39	
			0.93	-	13900 (62000)					1.13	I	14000 (62100)		60	<b>4E195</b>	39	
			1.12	I	28100 (125000)					1.12	I	27400 (122000)		60	<b>4F190</b>	39	
			1.22	I	28100 (125000)					1.22	I	27400 (122000)		60	<b>4F195</b>	39	
31.9	110000 (12400)		1.12	I	27400 (122000)		38.5	91200 (10300)		1.12	I	28200 (125000)		60	<b>4F190</b>	46	
			1.22	I	27400 (122000)					1.22	I	28200 (125000)		60	<b>4F195</b>	46	
27.6	127000 (14300)		1.12	I	26700 (119000)		33.3	105000 (11900)		1.12	I	27600 (123000)		60	<b>4F190</b>	53	
			1.22	I	26700 (119000)					1.22	I	27600 (123000)		60	<b>4F195</b>	53	
24.4	144000 (16300)		1.11	I	25900 (115000)		29.4	119000 (13500)		1.12	I	27000 (120000)		60	<b>4F190</b>	60	
			1.11	I	25900 (115000)					1.22	I	27000 (120000)		60	<b>4F195</b>	60	
21.6	163000 (18400)		0.91	-	25100 (112000)		26.0	135000 (15200)		0.91	-	26300 (117000)		60	<b>4F190</b>	67	
			0.98	-	25100 (112000)					1.07	I	26300 (117000)		60	<b>4F195</b>	67	
19.7	178000 (20100)		0.90	-	24500 (109000)		23.8	147000 (16600)		0.91	-	25800 (115000)		60	<b>4F190</b>	74	
			0.90	-	24500 (109000)					1.07	I	25800 (115000)		60	<b>4F195</b>	74	
18.1	193000 (21900)		0.82	-	21100 (94000)		21.9	160000 (18100)		0.90	-	25200 (112000)		60	<b>4F195</b>	80	

Notes: [1] For Y4 Double Reductions (4XXXDX) refer to the above table; for Y4 single reduction refer to tables on pages 2.91-2.130.  
[2] Variable Frequency Drive (VFD) notes (see page 2.8 for Constant Torque Speed Ranges):  
All 1HP+ motors require EP suffix in model number and can be used with a VFD, unless noted.  
(#) = Mounting positions Y2, F2, G2, K2, V2, W2 operation is limited to 75 %ED (duty cycle) for a 10 minute total cycle (7.5 minutes max. on time).

# Y4 Mounting Single Reduction Selection Tables

**1/4 HP  
(0.2 kW)**

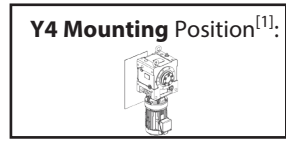

Dimension Pages:  
Single Reduction 2.132-2.143  
Single Reduction, Y2 2.144  
Double Reduction 2.146-2.161  
Double Reduction, Y2 2.162

Frequency	50 Hz	60 Hz
Input Speed	1450 RPM	1750 RPM
Number of Poles	4	

50Hz					60 Hz					Selection							
Output Speed (RPM)	Output Torque		Service Factor		Solid Shaft Overhung Load		Output Speed (RPM)	Output Torque		Service Factor		Solid Shaft Overhung Load		Base			VFD <sup>[1]</sup>
	in-lbs	(N·m)	SF	AGMA Class	lbs	(N)		in-lbs	(N·m)	SF	AGMA Class	lbs	(N)	Motor Power Code	Frame Size	Ratio	
8.12	1920 (217)		2.80	III	6090 (27100)		9.80	1590 (180)		2.80	III	6110 (27200)		02	<b>4A100</b>	179	(a)
7.02	2220 (251)		2.58	III	6070 (27000)		8.47	1840 (208)		2.58	III	6090 (27100)		02	<b>4A100</b>	207	(a)
5.84	2670 (302)		2.18	III	6030 (26800)		7.04	2210 (250)		2.18	III	6070 (27000)		02	<b>4A100</b>	249	(a)
			2.53	III	6030 (26800)					2.81	III	6070 (27000)		02	<b>4A105</b>	249	(a)
4.76	3270 (370)		2.17	III	5960 (26500)		5.75	2710 (306)		2.17	III	6020 (26800)		02	<b>4A100</b>	305	(a)
			2.51	III	5960 (26500)					2.83	III	6020 (26800)		02	<b>4A105</b>	305	(a)
3.48	4480 (506)		1.05	I	5790 (25800)		4.20	3710 (419)		1.05	I	5910 (26300)		02	<b>4A100</b>	417	(a)
			1.43	II	5790 (25800)					1.43	II	5910 (26300)		02	<b>4A105</b>	417	(a)

Notes: [1] For double reduction and 1/8 HP single reduction Y4 ratings, refer to selection tables on pages 2.91 thru 2.130.  
[2] Variable Frequency Drive (VFD) notes (see page 2.8 for Constant Torque Speed Ranges):

# Y4 Mounting Single Reduction Selection Tables

**1/3 HP  
(0.25 kW)**

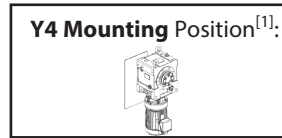

Dimension Pages:  
Single Reduction 2.132-2.143  
Single Reduction, Y2 2.144  
Double Reduction 2.146-2.161  
Double Reduction, Y2 2.162

Frequency	50 Hz	60 Hz
Input Speed	1450 RPM	1750 RPM
Number of Poles	4	

50Hz					60 Hz					Selection							
Output Speed (RPM)	Output Torque		Service Factor		Solid Shaft Overhung Load		Output Speed (RPM)	Output Torque		Service Factor <sup>[1]</sup>		Solid Shaft Overhung Load		Base			VFD <sup>[1]</sup>
	in-lbs	(N·m)	SF	AGMA Class	lbs	(N)		in-lbs	(N·m)	SF	AGMA Class	lbs	(N)	Motor Power Code	Frame Size	Ratio	
9.63	2020	(228)	3.12	III	6080	(27000)	11.6	1680	(189)	3.12	III	6100	(27100)	03	<b>4A100</b>	151	(a)
8.12	2400	(271)	2.24	III	6050	(26900)	9.80	1990	(225)	2.24	III	6080	(27100)	03	<b>4A100</b>	179	(a)
			3.10	III	6050	(26900)				3.10	III	6080	(27100)	03	<b>4A105</b>	179	(a)
7.02	2770	(313)	2.06	III	6020	(26800)	8.47	2300	(260)	2.06	III	6060	(27000)	03	<b>4A100</b>	207	(a)
			2.72	III	6020	(26800)				2.83	III	6060	(27000)	03	<b>4A105</b>	207	(a)
5.84	3340	(377)	1.74	II	5950	(26500)	7.04	2770	(313)	1.74	II	6020	(26800)	03	<b>4A100</b>	249	(a)
			2.02	III	5950	(26500)				2.24	III	6020	(26800)	03	<b>4A105</b>	249	(a)
4.76	4090	(462)	1.73	II	5850	(26000)	5.75	3390	(383)	1.73	II	5950	(26500)	03	<b>4A100</b>	305	(a)
			2.01	III	5850	(26000)				2.26	III	5950	(26500)	03	<b>4A105</b>	305	(a)
3.48	5600	(632)	0.84	-	5580	(24800)	4.20	4640	(524)	0.84	-	5760	(25600)	03	<b>4A100</b>	417	(a)
			1.15	I	5580	(24800)				1.15	I	5760	(25600)	03	<b>4A105</b>	417	(a)

# Y4 Mounting Single Reduction Selection Tables

**1/2 HP  
(0.4 kW)**

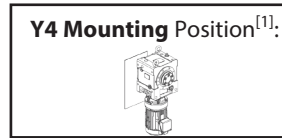

Dimension Pages:  
Single Reduction 2.132-2.143  
Single Reduction, Y2 2.144  
Double Reduction 2.146-2.161  
Double Reduction, Y2 2.162

Frequency	50 Hz	60 Hz
Input Speed	1450 RPM	1750 RPM
Number of Poles	4	

50Hz					60 Hz					Selection							
Output Speed (RPM)	Output Torque		Service Factor		Solid Shaft Overhung Load		Output Speed (RPM)	Output Torque		Service Factor <sup>[1]</sup>		Solid Shaft Overhung Load		Base			VFD <sup>[1]</sup>
	in-lbs	(N·m)	SF	AGMA Class	lbs	(N)		in-lbs	(N·m)	SF	AGMA Class	lbs	(N)	Motor Power Code	Frame Size	Ratio	
18.1	1720	(194)	3.17	III	6100	(27100)	21.9	1430	(161)	3.17	III	6120	(27200)	05	<b>4A100</b>	80	(a)
16.6	1880	(213)	3.17	III	6090	(27100)	20.0	1560	(176)	3.17	III	6110	(27200)	05	<b>4A100</b>	88	(a)
14.3	2180	(247)	3.03	III	6070	(27000)	17.2	1810	(204)	3.03	III	6090	(27100)	05	<b>4A100</b>	102	(a)
12.9	2410	(272)	2.44	III	6050	(26900)	15.6	2000	(225)	2.44	III	6080	(27100)	05	<b>4A100</b>	112	(a)
			3.00	III	6050	(26900)				3.00	III	6080	(27100)	05	<b>4A105</b>	112	(a)
11.8	2630	(298)	2.44	III	6030	(26800)	14.3	2180	(247)	2.44	III	6070	(27000)	05	<b>4A100</b>	123	(a)
			3.00	III	6030	(26800)				3.00	III	6070	(27000)	05	<b>4A105</b>	123	(a)
9.63	3240	(366)	1.95	II	5970	(26500)	11.6	2680	(303)	1.95	II	6020	(26800)	05	<b>4A100</b>	151	(a)
			2.71	III	5970	(26500)				2.71	III	6020	(26800)	05	<b>4A105</b>	151	(a)
8.12	3840	(434)	1.40	II	5890	(26200)	9.80	3180	(359)	1.40	II	5970	(26600)	05	<b>4A100</b>	179	(a)
			1.94	II	5890	(26200)				1.94	II	5970	(26600)	05	<b>4A105</b>	179	(a)
			2.36	III	5890	(26200)				2.36	III	5970	(26600)	05	<b>4A110</b>	179	(a)
			2.78	III	5890	(26200)				2.78	III	5970	(26600)	05	<b>4A115</b>	179	(a)
7.02	4440	(502)	1.29	I	5800	(25800)	8.47	3680	(416)	1.29	I	5910	(26300)	05	<b>4A100</b>	207	(a)
			1.70	II	5800	(25800)				1.77	II	5910	(26300)	05	<b>4A105</b>	207	(a)
			2.15	III	5800	(25800)				2.15	III	5910	(26300)	05	<b>4A110</b>	207	(a)
			2.53	III	5800	(25800)				2.53	III	5910	(26300)	05	<b>4A115</b>	207	(a)
5.84	5340	(604)	1.09	I	5630	(25000)	7.04	4430	(500)	1.09	I	5800	(25800)	05	<b>4A100</b>	249	(a)
			1.26	I	5630	(25000)				1.40	II	5800	(25800)	05	<b>4A105</b>	249	(a)
			1.67	II	5630	(25000)				1.67	II	5800	(25800)	05	<b>4A110</b>	249	(a)
			1.89	II	5630	(25000)				1.89	II	5800	(25800)	05	<b>4A115</b>	249	(a)
			2.14	III	5630	(25000)				2.14	III	5800	(25800)	05	<b>4A120</b>	249	(a)
			2.39	III	9860	(43900)				2.39	III	9920	(44100)	05	<b>4B120</b>	249	(a)
4.76	6550	(740)	1.08	I	5350	(23800)	5.75	5420	(613)	1.08	I	5610	(25000)	05	<b>4A100</b>	305	(a)
			1.26	I	5350	(23800)				1.41	II	5610	(25000)	05	<b>4A105</b>	305	(a)
			1.65	II	5350	(23800)				1.65	II	5610	(25000)	05	<b>4A110</b>	305	(a)
			1.74	II	5350	(23800)				1.74	II	5610	(25000)	05	<b>4A115</b>	305	(a)
			2.36	III	9760	(43400)				2.36	III	9850	(43800)	05	<b>4B120</b>	305	(a)
			2.57	III	9760	(43400)				2.83	III	9850	(43800)	05	<b>4B125</b>	305	(a)

Notes: [1] For double reduction and 1/8 HP single reduction Y4 ratings, refer to selection tables on pages 2.91 thru 2.130.  
[2] Variable Frequency Drive (VFD) notes (see page 2.8 for Constant Torque Speed Ranges):

Notes: [1] For double reduction and 1/8 HP single reduction Y4 ratings, refer to selection tables on pages 2.91 thru 2.130.  
[2] Variable Frequency Drive (VFD) notes (see page 2.8 for Constant Torque Speed Ranges):

# Y4 Mounting Single Reduction Selection Tables

**3/4 HP**  
(0.55 kW)

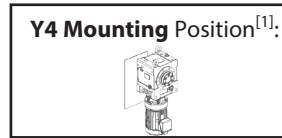

Dimension Pages:  
Single Reduction 2.132-2.143  
Single Reduction, Y2 2.144  
Double Reduction 2.146-2.161  
Double Reduction, Y2 2.162

Frequency	50 Hz	60 Hz
Input Speed	1450 RPM	1750 RPM
Number of Poles	4	

50Hz					60 Hz					Selection							
Output Speed (RPM)	Output Torque		Service Factor		Solid Shaft Overhung Load		Output Speed (RPM)	Output Torque		Service Factor <sup>[1]</sup>		Solid Shaft Overhung Load		Base			VFD <sup>[1]</sup>
	in-lbs	(N·m)	SF	AGMA Class	lbs	(N)		in-lbs	(N·m)	SF	AGMA Class	lbs	(N)	Motor Power Code	Frame Size	Ratio	
18.1	2360	(267)	2.31	III	6050	(26900)	21.9	1960	(221)	2.31	III	6080	(27100)	08	<b>4A100</b>	80	(a)
			3.04	III	6050	(26900)				3.04	III	6080	(27100)	08	<b>4A105</b>	80	(a)
16.6	2590	(292)	2.31	III	6030	(26800)	20.0	2140	(242)	2.31	III	6070	(27000)	08	<b>4A100</b>	88	(a)
			3.04	III	6030	(26800)				3.04	III	6070	(27000)	08	<b>4A105</b>	88	(a)
14.3	3000	(339)	2.20	III	5990	(26700)	17.2	2490	(281)	2.20	III	6040	(26900)	08	<b>4A100</b>	102	(a)
			2.89	III	5990	(26700)				2.89	III	6040	(26900)	08	<b>4A105</b>	102	(a)
12.9	3310	(374)	1.77	II	5960	(26500)	15.6	2740	(310)	1.77	II	6020	(26800)	08	<b>4A100</b>	112	(a)
			2.18	III	5960	(26500)				2.18	III	6020	(26800)	08	<b>4A105</b>	112	(a)
			2.73	III	5960	(26500)				2.73	III	6020	(26800)	08	<b>4A110</b>	112	(a)
11.8	3620	(409)	1.77	II	5920	(26300)	14.3	3000	(339)	1.77	II	5990	(26700)	08	<b>4A100</b>	123	(a)
			2.18	III	5920	(26300)				2.18	III	5990	(26700)	08	<b>4A105</b>	123	(a)
			2.73	III	5920	(26300)				2.73	III	5990	(26700)	08	<b>4A110</b>	123	(a)
			3.15	III	5920	(26300)				3.15	III	5990	(26700)	08	<b>4A115</b>	123	(a)
9.63	4450	(503)	1.42	II	5800	(25800)	11.6	3690	(416)	1.42	II	5910	(26300)	08	<b>4A100</b>	151	(a)
			1.97	II	5800	(25800)				1.97	II	5910	(26300)	08	<b>4A105</b>	151	(a)
			2.36	III	5800	(25800)				2.36	III	5910	(26300)	08	<b>4A110</b>	151	(a)
			2.57	III	5800	(25800)				2.57	III	5910	(26300)	08	<b>4A115</b>	151	(a)
8.12	5280	(596)	1.02	I	5640	(25100)	9.80	4370	(494)	1.02	I	5810	(25800)	08	<b>4A100</b>	179	(a)
			1.41	II	5640	(25100)				1.41	II	5810	(25800)	08	<b>4A105</b>	179	(a)
			1.72	II	5640	(25100)				1.72	II	5810	(25800)	08	<b>4A110</b>	179	(a)
			2.02	III	5640	(25100)				2.02	III	5810	(25800)	08	<b>4A115</b>	179	(a)
			2.16	III	5640	(25100)				2.16	III	5810	(25800)	08	<b>4A120</b>	179	(a)
			2.96	III	9860	(43900)				3.12	III	9920	(44100)	08	<b>4B120</b>	179	(a)
7.02	6100	(690)	0.94	-	5460	(24300)	8.47	5060	(571)	0.94	-	5690	(25300)	08	<b>4A100</b>	207	(a)
			1.24	I	5460	(24300)				1.29	I	5690	(25300)	08	<b>4A105</b>	207	(a)
			1.56	II	5460	(24300)				1.56	II	5690	(25300)	08	<b>4A110</b>	207	(a)
			1.84	II	5460	(24300)				1.84	II	5690	(25300)	08	<b>4A115</b>	207	(a)
			1.87	II	5460	(24300)				1.87	II	5690	(25300)	08	<b>4A120</b>	207	(a)
			2.37	III	9800	(43600)				2.37	III	9880	(43900)	08	<b>4B120</b>	207	(a)
			2.95	III	9800	(43600)				2.95	III	9880	(43900)	08	<b>4B125</b>	207	(a)
5.84	7350	(830)	0.92	-	5120	(22800)	7.04	6090	(688)	1.02	I	5470	(24300)	08	<b>4A105</b>	249	(a)
			1.22	I	5120	(22800)				1.22	I	5470	(24300)	08	<b>4A110</b>	249	(a)
			1.38	I	5120	(22800)				1.38	I	5470	(24300)	08	<b>4A115</b>	249	(a)
			1.55	II	5120	(22800)				1.55	II	5470	(24300)	08	<b>4A120</b>	249	(a)
			1.74	II	9690	(43100)				1.74	II	9800	(43600)	08	<b>4B120</b>	249	(a)
			2.07	III	9690	(43100)				2.18	III	9800	(43600)	08	<b>4B125</b>	249	(a)
			2.75	III	9690	(43100)				2.75	III	9800	(43600)	08	<b>4B140</b>	249	(a)
			3.10	III	9690	(43100)				3.10	III	9800	(43600)	08	<b>4B160</b>	249	(a), (-)

Notes: [1] For double reduction and 1/8 HP single reduction Y4 ratings, refer to selection tables on pages 2.91 thru 2.130.  
[2] Variable Frequency Drive (VFD) notes (see page 2.8 for Constant Torque Speed Ranges):

# Y4 Mounting Single Reduction Selection Tables

**3/4 HP**  
(0.55 kW)

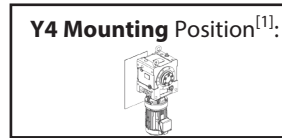

Dimension Pages:  
Single Reduction 2.132-2.143  
Single Reduction, Y2 2.144  
Double Reduction 2.146-2.161  
Double Reduction, Y2 2.162

Frequency	50 Hz	60 Hz
Input Speed	1450 RPM	1750 RPM
Number of Poles	4	

50Hz					60 Hz					Selection							
Output Speed (RPM)	Output Torque		Service Factor		Solid Shaft Overhung Load		Output Speed (RPM)	Output Torque		Service Factor <sup>[1]</sup>		Solid Shaft Overhung Load		Base			VFD <sup>[1]</sup>
	in-lbs	(N·m)	SF	AGMA Class	lbs	(N)		in-lbs	(N·m)	SF	AGMA Class	lbs	(N)	Motor Power Code	Frame Size	Ratio	
4.76	9000	(1020)	0.91	-	4520	(20100)	5.75	7460	(843)	1.03	I	5090	(22600)	08	<b>4A105</b>	305	(a)
			1.20	I	4520	(20100)				1.20	I	5090	(22600)	08	<b>4A110</b>	305	(a)
			1.27	I	4520	(20100)				1.27	I	5090	(22600)	08	<b>4A115</b>	305	(a)
			1.72	II	9500	(42300)				1.72	II	9680	(43000)	08	<b>4B120</b>	305	(a)
			1.87	II	9500	(42300)				2.05	III	9680	(43000)	08	<b>4B125</b>	305	(a)
2.53	III	9500	(42300)	2.53	III	9680	(43000)	08	<b>4B140</b>	305	(a)						

Notes: [1] For double reduction and 1/8 HP single reduction Y4 ratings, refer to selection tables on pages 2.91 thru 2.130.  
[2] Variable Frequency Drive (VFD) notes (see page 2.8 for Constant Torque Speed Ranges):

Selection Tables

Selection Tables

# Y4 Mounting Single Reduction Selection Tables

**1 HP**  
(0.75 kW)

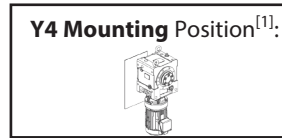

Dimension Pages:  
Single Reduction 2.132-2.143  
Single Reduction, Y2 2.144  
Double Reduction 2.146-2.161  
Double Reduction, Y2 2.162

Frequency	50 Hz	60 Hz
Input Speed	1450 RPM	1750 RPM
Number of Poles	4	

50Hz					60 Hz					Selection							
Output Speed (RPM)	Output Torque		Service Factor		Solid Shaft Overhung Load		Output Speed (RPM)	Output Torque		Service Factor <sup>[1]</sup>		Solid Shaft Overhung Load		Base			VFD <sup>[1]</sup>
	in-lbs	(N·m)	SF	AGMA Class	lbs	(N)		in-lbs	(N·m)	SF	AGMA Class	lbs	(N)	Motor Power Code	Frame Size	Ratio	
69.0	847	(96)	3.13	III	4930	(21900)	83.3	701	(79)	3.13	III	4670	(20800)	1	<b>4A100</b>	21	
51.8	1130	(128)	3.13	III	5340	(23800)	62.5	935	(106)	3.13	III	5070	(22500)	1	<b>4A100</b>	28	
41.2	1420	(160)	3.13	III	5690	(25300)	49.7	1180	(133)	3.13	III	5400	(24000)	1	<b>4A100</b>	35	
37.7	1550	(175)	3.13	III	5830	(26000)	45.5	1290	(145)	3.13	III	5540	(24600)	1	<b>4A100</b>	39	
31.9	1830	(207)	3.13	III	6090	(27100)	38.5	1520	(172)	3.13	III	5800	(25800)	1	<b>4A100</b>	46	
27.6	2120	(239)	3.13	III	6070	(27000)	33.3	1750	(198)	3.13	III	6030	(26800)	1	<b>4A100</b>	53	
24.4	2400	(271)	2.65	III	6050	(26900)	29.4	1990	(225)	2.65	III	6080	(27100)	1	<b>4A100</b>	60	
21.6	2710	(306)	2.54	III	6020	(26800)	26.0	2240	(254)	2.57	III	6060	(27000)	1	<b>4A100</b>	67	
			3.04	III	6020	(26800)				3.11	III	6060	(27000)		<b>4A105</b>	67	
19.7	2960	(335)	2.54	III	6000	(26700)	23.8	2450	(277)	2.57	III	6050	(26900)	1	<b>4A100</b>	74	
			3.04	III	6000	(26700)				3.11	III	6050	(26900)		<b>4A105</b>	74	
18.1	3220	(364)	1.69	II	5970	(26500)	21.9	2670	(302)	1.69	II	6030	(26800)	1	<b>4A100</b>	80	
			2.23	III	5970	(26500)				2.23	III	6030	(26800)		<b>4A105</b>	80	
			2.55	III	5970	(26500)				2.55	III	6030	(26800)		<b>4A110</b>	80	
			2.96	III	5970	(26500)				2.96	III	6030	(26800)		<b>4A115</b>	80	
16.6	3530	(399)	1.69	II	5930	(26400)	20.0	2920	(330)	1.69	II	6000	(26700)	1	<b>4A100</b>	88	
			2.23	III	5930	(26400)				2.23	III	6000	(26700)		<b>4A105</b>	88	
			2.55	III	5930	(26400)				2.55	III	6000	(26700)		<b>4A110</b>	88	
			2.96	III	5930	(26400)				2.96	III	6000	(26700)		<b>4A115</b>	88	
14.3	4090	(462)	1.61	II	5850	(26000)	17.2	3390	(383)	1.61	II	5950	(26500)	1	<b>4A100</b>	102	
			2.12	III	5850	(26000)				2.12	III	5950	(26500)		<b>4A105</b>	102	
			2.54	III	5850	(26000)				2.54	III	5950	(26500)		<b>4A110</b>	102	
			2.79	III	5850	(26000)				2.79	III	5950	(26500)		<b>4A115</b>	102	
12.9	4510	(510)	1.30	I	5780	(25700)	15.6	3740	(423)	1.30	I	5900	(26300)	1	<b>4A100</b>	112	
			1.60	II	5780	(25700)				1.60	II	5900	(26300)		<b>4A105</b>	112	
			2.00	III	5780	(25700)				2.00	III	5900	(26300)		<b>4A110</b>	112	
			2.41	III	5780	(25700)				2.41	III	5900	(26300)		<b>4A115</b>	112	
			2.53	III	5780	(25700)				2.53	III	5900	(26300)		<b>4A120</b>	112	
3.17	III	9910	(44100)	3.33	III	9960	(44300)	<b>4B120</b>	112								
11.8	4940	(558)	1.30	I	5710	(25400)	14.3	4090	(462)	1.30	I	5850	(26000)	1	<b>4A100</b>	123	
			1.60	II	5710	(25400)				1.60	II	5850	(26000)		<b>4A105</b>	123	
			2.00	III	5710	(25400)				2.00	III	5850	(26000)		<b>4A110</b>	123	
			2.31	III	5710	(25400)				2.31	III	5850	(26000)		<b>4A115</b>	123	
			3.17	III	9890	(44000)				3.33	III	9940	(44200)		<b>4B120</b>	123	

Notes: [1] For double reduction and 1/8 HP single reduction Y4 ratings, refer to selection tables on pages 2.91 thru 2.130.  
[2] Variable Frequency Drive (VFD) notes (see page 2.8 for Constant Torque Speed Ranges):

# Y4 Mounting Single Reduction Selection Tables

**1 HP**  
(0.75 kW)

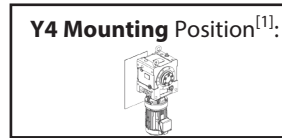

Dimension Pages:  
Single Reduction 2.132-2.143  
Single Reduction, Y2 2.144  
Double Reduction 2.146-2.161  
Double Reduction, Y2 2.162

Frequency	50 Hz	60 Hz
Input Speed	1450 RPM	1750 RPM
Number of Poles	4	

50Hz					60 Hz					Selection							
Output Speed (RPM)	Output Torque		Service Factor		Solid Shaft Overhung Load		Output Speed (RPM)	Output Torque		Service Factor <sup>[1]</sup>		Solid Shaft Overhung Load		Base			VFD <sup>[1]</sup>
	in-lbs	(N·m)	SF	AGMA Class	lbs	(N)		in-lbs	(N·m)	SF	AGMA Class	lbs	(N)	Motor Power Code	Frame Size	Ratio	
9.63	6070	(685)	1.04	I	5470	(24300)	11.6	5030	(568)	1.04	I	5690	(25300)	1	<b>4A100</b>	151	
			1.45	II	5470	(24300)				1.45	II	5690	(25300)		<b>4A105</b>	151	
			1.73	II	5470	(24300)				1.73	II	5690	(25300)		<b>4A110</b>	151	
			1.88	II	5470	(24300)				1.88	II	5690	(25300)		<b>4A115</b>	151	
			2.55	III	9800	(43600)				2.55	III	9880	(44000)		<b>4B120</b>	151	
3.12	III	9800	(43600)	3.17	III	9880	(44000)	<b>4B125</b>	151								
8.12	7200	(813)	1.03	I	5170	(23000)	9.80	5960	(674)	1.03	I	5490	(24400)	1	<b>4A105</b>	179	
			1.26	I	5170	(23000)				1.26	I	5490	(24400)		<b>4A110</b>	179	
			1.48	II	5170	(23000)				1.48	II	5490	(24400)		<b>4A115</b>	179	
			1.59	II	5170	(23000)				1.59	II	5490	(24400)		<b>4A120</b>	179	
			2.17	III	9700	(43200)				2.29	III	9810	(43600)		<b>4B120</b>	179	
2.63	III	9700	(43200)	3.04	III	9810	(43600)	<b>4B125</b>	179								
3.16	III	9700	(43200)	3.16	III	9810	(43600)	<b>4B160</b>	179	(-)							
7.02	8320	(940)	0.91	-	4790	(21300)	8.47	6900	(779)	0.94	-	5250	(23400)	1	<b>4A105</b>	207	
			1.15	I	4790	(21300)				1.15	I	5250	(23400)		<b>4A110</b>	207	
			1.35	I	4790	(21300)				1.35	I	5250	(23400)		<b>4A115</b>	207	
			1.37	I	4790	(21300)				1.37	I	5250	(23400)		<b>4A120</b>	207	
			1.74	II	9580	(42600)				1.74	II	9730	(43300)		<b>4B120</b>	207	
2.16	III	9580	(42600)	2.16	III	9730	(43300)	<b>4B125</b>	207								
2.73	III	9580	(42600)	2.73	III	9730	(43300)	<b>4B140</b>	207								
5.84	10000	(1130)	1.01	I	4030	(17900)	7.04	8300	(938)	1.01	I	4800	(21300)	1	<b>4A115</b>	249	
			1.14	I	4030	(17900)				1.14	I	4800	(21300)		<b>4A120</b>	249	
			1.28	I	9370	(41700)				1.28	I	9590	(42600)		<b>4B120</b>	249	
			1.52	II	9370	(41700)				1.60	II	9590	(42600)		<b>4B125</b>	249	
			2.02	III	9370	(41700)				2.02	III	9590	(42600)		<b>4B140</b>	249	
2.27	III	9370	(41700)	2.27	III	9590	(42600)	<b>4B160</b>	249								
4.76	12300	(1390)	0.93	-	2330	(10300)	5.75	10200	(1150)	0.93	-	3950	(17600)	1	<b>4A115</b>	305	
			1.26	I	9000	(40100)				1.26	I	9340	(41600)		<b>4B120</b>	305	
			1.37	I	9000	(40100)				1.51	II	9340	(41600)		<b>4B125</b>	305	
			1.85	II	9000	(40100)				1.85	II	9340	(41600)		<b>4B140</b>	305	
2.02	III	15700	(70100)	2.02	III	15900	(70600)	<b>4C140</b>	305								

Notes: [1] For double reduction and 1/8 HP single reduction Y4 ratings, refer to selection tables on pages 2.91 thru 2.130.  
[2] Variable Frequency Drive (VFD) notes (see page 2.8 for Constant Torque Speed Ranges):



# Y4 Mounting Single Reduction Selection Tables

**1.5 HP**  
(1.1 kW)

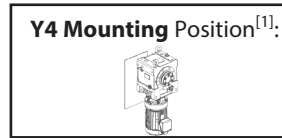

Dimension Pages:

Single Reduction	2.132-2.143
Single Reduction, Y2	2.144
Double Reduction	2.146-2.161
Double Reduction, Y2	2.162

Frequency	50 Hz	60 Hz
Input Speed	1450 RPM	1750 RPM
Number of Poles	4	

50Hz					60 Hz					Selection							
Output Speed (RPM)	Output Torque		Service Factor		Solid Shaft Overhung Load		Output Speed (RPM)	Output Torque		Service Factor <sup>[1]</sup>		Solid Shaft Overhung Load		Base			VFD <sup>[1]</sup>
	in-lbs	(N·m)	SF	AGMA Class	lbs	(N)		in-lbs	(N·m)	SF	AGMA Class	lbs	(N)	Motor Power Code	Frame Size	Ratio	
69.0	1240	(140)	2.13	III	4870	(21700)	83.3	1030	(116)	2.13	III	4620	(20600)	1H	<b>4A100</b>	21	
			2.89	III	4870	(21700)				2.89	III	4620	(20600)	1H	<b>4A105</b>	21	
51.8	1660	(187)	2.13	III	5270	(23400)	62.5	1370	(155)	2.13	III	5010	(22300)	1H	<b>4A100</b>	28	
			2.89	III	5270	(23400)				2.89	III	5010	(22300)	1H	<b>4A105</b>	28	
41.2	2080	(235)	2.13	III	5600	(24900)	49.7	1720	(195)	2.13	III	5330	(23700)	1H	<b>4A100</b>	35	
			2.89	III	5600	(24900)				2.89	III	5330	(23700)	1H	<b>4A105</b>	35	
37.7	2280	(257)	2.13	III	5740	(25500)	45.5	1890	(213)	2.13	III	5460	(24300)	1H	<b>4A100</b>	39	
			2.89	III	5740	(25500)				2.89	III	5460	(24300)	1H	<b>4A105</b>	39	
31.9	2690	(304)	2.13	III	5990	(26600)	38.5	2230	(252)	2.13	III	5700	(25400)	1H	<b>4A100</b>	46	
			2.89	III	5990	(26600)				2.89	III	5700	(25400)	1H	<b>4A105</b>	46	
27.6	3100	(351)	2.13	III	5980	(26600)	33.3	2570	(291)	2.13	III	5920	(26300)	1H	<b>4A100</b>	53	
			2.89	III	5980	(26600)				2.89	III	5920	(26300)	1H	<b>4A105</b>	53	
24.4	3520	(397)	1.81	II	5930	(26400)	29.4	2910	(329)	1.81	II	6000	(26700)	1H	<b>4A100</b>	60	
			2.23	III	5930	(26400)				2.23	III	6000	(26700)	1H	<b>4A105</b>	60	
			2.89	III	5930	(26400)				2.89	III	6000	(26700)	1H	<b>4A110</b>	60	
21.6	3970	(449)	1.73	II	5870	(26100)	26.0	3290	(372)	1.75	II	5960	(26500)	1H	<b>4A100</b>	67	
			2.08	III	5870	(26100)				2.12	III	5960	(26500)	1H	<b>4A105</b>	67	
			2.48	III	5870	(26100)				2.48	III	5960	(26500)	1H	<b>4A110</b>	67	
			2.83	III	5870	(26100)				2.83	III	5960	(26500)	1H	<b>4A115</b>	67	
			2.87	III	5870	(26100)				2.87	III	5960	(26500)	1H	<b>4A120</b>	67	
			1.73	II	5870	(26100)				1.75	II	5960	(26500)	1H	<b>4A120</b>	67	
19.7	4350	(491)	1.73	II	5810	(25900)	23.8	3600	(407)	1.75	II	5920	(26300)	1H	<b>4A100</b>	74	
			2.08	III	5810	(25900)				2.12	III	5920	(26300)	1H	<b>4A105</b>	74	
			2.48	III	5810	(25900)				2.48	III	5920	(26300)	1H	<b>4A110</b>	74	
			2.63	III	5810	(25900)				2.63	III	5920	(26300)	1H	<b>4A115</b>	74	
18.1	4730	(534)	1.15	I	5750	(25600)	21.9	3920	(443)	1.15	I	5880	(26100)	1H	<b>4A100</b>	80	
			1.52	II	5750	(25600)				1.52	II	5880	(26100)	1H	<b>4A105</b>	80	
			1.74	II	5750	(25600)				1.74	II	5880	(26100)	1H	<b>4A110</b>	80	
			2.02	III	5750	(25600)				2.02	III	5880	(26100)	1H	<b>4A115</b>	80	
			2.41	III	5750	(25600)				2.41	III	5880	(26100)	1H	<b>4A120</b>	80	
			2.81	III	9650	(42900)				2.81	III	9180	(40800)	1H	<b>4B120</b>	80	
16.6	5170	(584)	1.15	I	5660	(25200)	20.0	4290	(484)	1.15	I	5820	(25900)	1H	<b>4A100</b>	88	
			1.52	II	5660	(25200)				1.52	II	5820	(25900)	1H	<b>4A105</b>	88	
			1.74	II	5660	(25200)				1.74	II	5820	(25900)	1H	<b>4A110</b>	88	
			2.02	III	5660	(25200)				2.02	III	5820	(25900)	1H	<b>4A115</b>	88	
			2.21	III	5660	(25200)				2.21	III	5820	(25900)	1H	<b>4A120</b>	88	
			2.81	III	9870	(43900)				2.81	III	9400	(41800)	1H	<b>4B120</b>	88	

Notes: [1] For double reduction and 1/8 HP single reduction Y4 ratings, refer to selection tables on pages 2.91 thru 2.130.  
[2] Variable Frequency Drive (VFD) notes (see page 2.8 for Constant Torque Speed Ranges):

# Y4 Mounting Single Reduction Selection Tables

**1.5 HP**  
(1.1 kW)

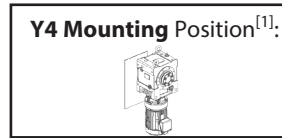

Dimension Pages:

Single Reduction	2.132-2.143
Single Reduction, Y2	2.144
Double Reduction	2.146-2.161
Double Reduction, Y2	2.162

Frequency	50 Hz	60 Hz
Input Speed	1450 RPM	1750 RPM
Number of Poles	4	

50Hz					60 Hz					Selection							
Output Speed (RPM)	Output Torque		Service Factor		Solid Shaft Overhung Load		Output Speed (RPM)	Output Torque		Service Factor <sup>[1]</sup>		Solid Shaft Overhung Load		Base			VFD <sup>[1]</sup>
	in-lbs	(N·m)	SF	AGMA Class	lbs	(N)		in-lbs	(N·m)	SF	AGMA Class	lbs	(N)	Motor Power Code	Frame Size	Ratio	
14.3	6000	(678)	1.10	I	5490	(24400)	17.2	4970	(562)	1.10	I	5700	(25400)	1H	<b>4A100</b>	102	
			1.45	II	5490	(24400)				1.45	II	5700	(25400)	1H	<b>4A105</b>	102	
			1.73	II	5490	(24400)				1.73	II	5700	(25400)	1H	<b>4A110</b>	102	
			1.90	II	5490	(24400)				1.90	II	5700	(25400)	1H	<b>4A115</b>	102	
			2.61	III	9810	(43600)				2.72	III	9770	(43500)	1H	<b>4B120</b>	102	
12.9	6620	(748)	0.89	-	5330	(23700)	15.6	5490	(620)	0.89	-	5600	(24900)	1H	<b>4A100</b>	112	
			1.09	I	5330	(23700)				1.09	I	5600	(24900)	1H	<b>4A105</b>	112	
			1.37	I	5330	(23700)				1.37	I	5600	(24900)	1H	<b>4A110</b>	112	
			1.64	II	5330	(23700)				1.64	II	5600	(24900)	1H	<b>4A115</b>	112	
			1.72	II	5330	(23700)				1.72	II	5600	(24900)	1H	<b>4A120</b>	112	
11.8	7240	(818)	0.89	-	5150	(22900)	14.3	6000	(678)	0.89	-	5490	(24400)	1H	<b>4A100</b>	123	
			1.09	I	5150	(22900)				1.09	I	5490	(24400)	1H	<b>4A105</b>	123	
			1.37	I	5150	(22900)				1.37	I	5490	(24400)	1H	<b>4A110</b>	123	
			1.58	II	5150	(22900)				1.58	II	5490	(24400)	1H	<b>4A115</b>	123	
			2.16	III	9700	(43100)				2.27	III	9810	(43600)	1H	<b>4B120</b>	123	
9.63	8900	(1010)	0.99	-	4560	(20300)	11.6	7370	(833)	0.99	-	5110	(22700)	1H	<b>4A105</b>	151	
			1.18	I	4560	(20300)				1.18	I	5110	(22700)	1H	<b>4A110</b>	151	
			1.28	I	4560	(20300)				1.28	I	5110	(22700)	1H	<b>4A115</b>	151	
			1.74	II	9510	(42300)				1.74	II	9680	(43100)	1H	<b>4B120</b>	151	
			2.13	III	9510	(42300)				2.16	III	9680	(43100)	1H	<b>4B125</b>	151	
8.12	10600	(1190)	0.86	-	3720	(16600)	9.80	8740	(988)	0.86	-	4620	(20600)	1H	<b>4A110</b>	179	
			1.01	I	3720	(16600)				1.01	I	4620	(20600)	1H	<b>4A115</b>	179	
			1.08	I	3720	(16600)				1.08	I	4620	(20600)	1H	<b>4A120</b>	179	
			1.48	II	9290	(41300)				1.56	II	9530	(42400)	1H	<b>4B120</b>	179	
			1.79	II	9290	(41300)				2.07	III	9530	(42400)	1H	<b>4B125</b>	179	
			2.16	III	9290	(41300)				2.16	III	9530	(42400)	1H	<b>4B160</b>	179	

Notes: [1] For double reduction and 1/8 HP single reduction Y4 ratings, refer to selection tables on pages 2.91 thru 2.130.  
[2] Variable Frequency Drive (VFD) notes (see page 2.8 for Constant Torque Speed Ranges):

# Y4 Mounting Single Reduction Selection Tables

**1.5 HP**  
(1.1 kW)

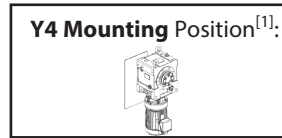

Dimension Pages:  
Single Reduction 2.132-2.143  
Single Reduction, Y2 2.144  
Double Reduction 2.146-2.161  
Double Reduction, Y2 2.162

Frequency	50 Hz	60 Hz
Input Speed	1450 RPM	1750 RPM
Number of Poles	4	

50Hz					60 Hz					Selection							
Output Speed (RPM)	Output Torque		Service Factor		Solid Shaft Overhung Load		Output Speed (RPM)	Output Torque		Service Factor <sup>[1]</sup>		Solid Shaft Overhung Load		Base			VFD <sup>[1]</sup>
	in-lbs	(N·m)	SF	AGMA Class	lbs	(N)		in-lbs	(N·m)	SF	AGMA Class	lbs	(N)	Motor Power Code	Frame Size	Ratio	
7.02	12200 (1380)		0.78	-	2400 (10700)	8.47	10100 (1140)	0.78	-	3980 (17700)	1H	<b>4A110</b>	207				
			0.92	-	2400 (10700)			0.92	-	3980 (17700)	1H	<b>4A115</b>	207				
			0.94	-	2400 (10700)			0.94	-	3980 (17700)	1H	<b>4A120</b>	207				
			1.19	I	9020 (40100)			1.19	I	9350 (41600)	1H	<b>4B120</b>	207				
			1.47	II	9020 (40100)			1.47	II	9350 (41600)	1H	<b>4B125</b>	207				
			1.86	II	9020 (40100)			1.86	II	9350 (41600)	1H	<b>4B140</b>	207				
			2.02	III	15800 (70100)			2.02	III	15900 (70600)	1H	<b>4C140</b>	207				
5.84	14700 (1660)		1.03	I	8510 (37900)	7.04	12200 (1380)	1.09	I	9020 (40100)	1H	<b>4B125</b>	249				
			1.38	I	8510 (37900)			1.38	I	9020 (40100)	1H	<b>4B140</b>	249				
			1.55	II	8510 (37900)			1.55	II	9020 (40100)	1H	<b>4B160</b>	249				
			2.02	III	15600 (69300)			2.02	III	15800 (70100)	1H	<b>4C160</b>	249				
			2.02	III	21800 (97000)			2.02	III	21900 (97500)	1H	<b>4D160</b>	249				
4.76	18000 (2030)		0.93	-	7630 (33900)	5.75	14900 (1690)	1.03	I	8460 (37600)	1H	<b>4B125</b>	305				
			1.26	I	7630 (33900)			1.26	I	8460 (37600)	1H	<b>4B140</b>	305				
			1.38	I	15300 (68000)			1.38	I	15600 (69200)	1H	<b>4C140</b>	305				
			2.02	III	15300 (68000)			2.02	III	15600 (69200)	1H	<b>4C160</b>	305				
			2.02	III	21700 (96400)			2.02	III	21800 (97000)	1H	<b>4D160</b>	305				

# Y4 Mounting Single Reduction Selection Tables

**2 HP**  
(1.5 kW)

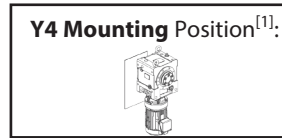

Dimension Pages:  
Single Reduction 2.132-2.143  
Single Reduction, Y2 2.144  
Double Reduction 2.146-2.161  
Double Reduction, Y2 2.162

Frequency	50 Hz	60 Hz
Input Speed	1450 RPM	1750 RPM
Number of Poles	4	

50Hz					60 Hz					Selection							
Output Speed (RPM)	Output Torque		Service Factor		Solid Shaft Overhung Load		Output Speed (RPM)	Output Torque		Service Factor <sup>[1]</sup>		Solid Shaft Overhung Load		Base			VFD <sup>[1]</sup>
	in-lbs	(N·m)	SF	AGMA Class	lbs	(N)		in-lbs	(N·m)	SF	AGMA Class	lbs	(N)	Motor Power Code	Frame Size	Ratio	
69.0	1690 (191)		1.56	II	4810 (21400)	83.3	1400 (158)	1.56	II	4570 (20300)	2	<b>4A100</b>	21				
			2.12	III	4810 (21400)			2.12	III	4570 (20300)	2	<b>4A105</b>	21				
			2.37	III	4810 (21400)			2.37	III	4570 (20300)	2	<b>4A110</b>	21				
			2.61	III	4810 (21400)			2.61	III	4570 (20300)	2	<b>4A115</b>	21				
			51.8	2260 (255)	1.56			II	5190 (23100)	62.5	1870 (211)	1.56	II		4940 (22000)	2	<b>4A100</b>
2.12	III	5190 (23100)	2.12	III	4940 (22000)	2	<b>4A105</b>	28									
2.37	III	5190 (23100)	2.37	III	4940 (22000)	2	<b>4A110</b>	28									
2.61	III	5190 (23100)	2.61	III	4940 (22000)	2	<b>4A115</b>	28									
41.2	2840 (321)		1.56	II	5500 (24500)	49.7	2350 (266)	1.56	II	5240 (23300)	2	<b>4A100</b>	35				
			2.12	III	5500 (24500)			2.12	III	5240 (23300)	2	<b>4A105</b>	35				
			2.37	III	5500 (24500)			2.37	III	5240 (23300)	2	<b>4A110</b>	35				
			2.61	III	5500 (24500)			2.61	III	5240 (23300)	2	<b>4A115</b>	35				
37.7	3100 (351)		1.56	II	5620 (25000)	45.5	2570 (291)	1.56	II	5360 (23900)	2	<b>4A100</b>	39				
			2.12	III	5620 (25000)			2.12	III	5360 (23900)	2	<b>4A105</b>	39				
			2.37	III	5620 (25000)			2.37	III	5360 (23900)	2	<b>4A110</b>	39				
			2.61	III	5620 (25000)			2.61	III	5360 (23900)	2	<b>4A115</b>	39				
			31.9	3670 (414)	1.56			II	5860 (26000)	38.5	3040 (343)	1.56	II		5590 (24900)	2	<b>4A100</b>
2.12	III	5860 (26000)	2.12	III	5590 (24900)	2	<b>4A105</b>	46									
2.37	III	5860 (26000)	2.37	III	5590 (24900)	2	<b>4A110</b>	46									
2.60	III	5860 (26000)	2.60	III	5590 (24900)	2	<b>4A115</b>	46									
27.6	4230 (478)		1.56	II	5830 (25900)	33.3	3510 (396)	1.56	II	5790 (25800)	2	<b>4A100</b>	53				
			2.12	III	5830 (25900)			2.12	III	5790 (25800)	2	<b>4A105</b>	53				
			2.37	III	5830 (25900)			2.37	III	5790 (25800)	2	<b>4A110</b>	53				
			2.60	III	5830 (25900)			2.60	III	5790 (25800)	2	<b>4A115</b>	53				
			2.70	III	5830 (25900)			2.70	III	5790 (25800)	2	<b>4A120</b>	53				
24.4	4800 (542)		1.32	I	5740 (25500)	29.4	3970 (449)	1.32	I	5870 (26100)	2	<b>4A100</b>	60				
			1.64	II	5740 (25500)			1.64	II	5870 (26100)	2	<b>4A105</b>	60				
			2.12	III	5740 (25500)			2.12	III	5870 (26100)	2	<b>4A110</b>	60				
			2.38	III	5740 (25500)			2.38	III	5870 (26100)	2	<b>4A115</b>	60				
21.6	5420 (612)		1.27	I	5610 (25000)	26.0	4490 (507)	1.28	I	5790 (25700)	2	<b>4A100</b>	67				
			1.52	II	5610 (25000)			1.56	II	5790 (25700)	2	<b>4A105</b>	67				
			1.82	II	5610 (25000)			1.82	II	5790 (25700)	2	<b>4A110</b>	67				
			2.07	III	5610 (25000)			2.07	III	5790 (25700)	2	<b>4A115</b>	67				
			2.11	III	5610 (25000)			2.11	III	5790 (25700)	2	<b>4A120</b>	67				
			2.64	III	9050 (40300)			2.64	III	8630 (38400)	2	<b>4B120</b>	67				
			3.20	III	9050 (40300)			3.26	III	8630 (38400)	2	<b>4B125</b>	67				

Notes: [1] For double reduction and 1/8 HP single reduction Y4 ratings, refer to selection tables on pages 2.91 thru 2.130.  
[2] Variable Frequency Drive (VFD) notes (see page 2.8 for Constant Torque Speed Ranges):

Notes: [1] For double reduction and 1/8 HP single reduction Y4 ratings, refer to selection tables on pages 2.91 thru 2.130.  
[2] Variable Frequency Drive (VFD) notes (see page 2.8 for Constant Torque Speed Ranges):

# Y4 Mounting Single Reduction Selection Tables

**2 HP  
(1.5 kW)**

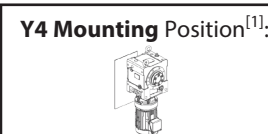

Dimension Pages:  
Single Reduction 2.132-2.143  
Single Reduction, Y2 2.144  
Double Reduction 2.146-2.161  
Double Reduction, Y2 2.162

Frequency	50 Hz	60 Hz
Input Speed	1450 RPM	1750 RPM
Number of Poles	4	

50Hz					60 Hz					Selection							
Output Speed (RPM)	Output Torque		Service Factor		Solid Shaft Overhung Load		Output Speed (RPM)	Output Torque		Service Factor <sup>[1]</sup>		Solid Shaft Overhung Load		Base			VFD <sup>[1]</sup>
	in-lbs	(N·m)	SF	AGMA Class	lbs	(N)		in-lbs	(N·m)	SF	AGMA Class	lbs	(N)	Motor Power Code	Frame Size	Ratio	
19.7	5930	(669)	1.27	I	5500	(24500)	23.8	4910	(555)	1.28	I	5710	(25400)	2	4A100	74	
			1.52	II	5500	(24500)				1.56	II	5710	(25400)				
			1.82	II	5500	(24500)				1.82	II	5710	(25400)				
			1.93	II	5500	(24500)				1.93	II	5710	(25400)				
			2.64	III	9260	(41200)				2.64	III	8830	(39300)				
			3.20	III	9260	(41200)				3.26	III	8830	(39300)				
18.1	6450	(729)	0.85	-	5370	(23900)	21.9	5340	(604)	0.85	-	5630	(25000)	2	4A100	80	
			1.12	I	5370	(23900)				1.12	I	5630	(25000)				
			1.28	I	5370	(23900)				1.28	I	5630	(25000)				
			1.48	II	5370	(23900)				1.48	II	5630	(25000)				
			1.77	II	5370	(23900)				1.77	II	5630	(25000)				
			2.06	III	9460	(42100)				2.06	III	9020	(40100)				
16.6	7050	(797)	0.85	-	5210	(23200)	20.0	5840	(660)	0.85	-	5520	(24600)	2	4A100	88	
			1.12	I	5210	(23200)				1.12	I	5520	(24600)				
			1.28	I	5210	(23200)				1.28	I	5520	(24600)				
			1.48	II	5210	(23200)				1.48	II	5520	(24600)				
			1.62	II	5210	(23200)				1.62	II	5520	(24600)				
			2.06	III	9670	(43000)				2.06	III	9230	(41100)				
14.3	8180	(925)	0.81	-	4840	(21500)	17.2	6780	(766)	0.81	-	5290	(23500)	2	4A100	102	
			1.06	I	4840	(21500)				1.06	I	5290	(23500)				
			1.27	I	4840	(21500)				1.27	I	5290	(23500)				
			1.40	II	4840	(21500)				1.40	II	5290	(23500)				
			1.91	II	9600	(42700)				2.00	III	9580	(42600)				
			2.31	III	9600	(42700)				2.51	III	9580	(42600)				
12.9	9030	(1020)	0.80	-	4500	(20000)	15.6	7480	(845)	0.80	-	5080	(22600)	2	4A105	112	
			1.00	I	4500	(20000)				1.00	I	5080	(22600)				
			1.21	I	4500	(20000)				1.21	I	5080	(22600)				
			1.26	I	4500	(20000)				1.26	I	5080	(22600)				
			1.58	II	9500	(42200)				1.66	II	9670	(43000)				
			1.92	II	9500	(42200)				2.12	III	9670	(43000)				
11.8	9880	(1120)	0.80	-	4100	(18300)	14.3	8180	(925)	0.80	-	4840	(21500)	2	4A105	123	
			1.00	I	4100	(18300)				1.00	I	4840	(21500)				
			1.16	I	4100	(18300)				1.16	I	4840	(21500)				
			1.58	II	9390	(41800)				1.66	II	9600	(42700)				
			1.92	II	9390	(41800)				2.12	III	9600	(42700)				
			2.30	III	9390	(41800)				2.30	III	9600	(42700)				
9.63	12100	(1370)	0.87	-	2480	(11000)	11.6	10100	(1140)	0.87	-	4010	(17800)	2	4A110	151	
			0.94	-	2480	(11000)				0.94	-	4010	(17800)				
			1.28	I	9030	(40200)				1.28	I	9360	(41600)				
			1.56	II	9030	(40200)				1.59	II	9360	(41600)				
			1.87	II	9030	(40200)				1.87	II	9360	(41600)				
			2.49	III	15700	(69900)				2.49	III	15000	(66700)				
8.12	14400	(1630)	1.09	I	8580	(38200)	9.80	11900	(1350)	1.14	I	9070	(40300)	2	4B120	179	
			1.32	I	8580	(38200)				1.52	II	9070	(40300)				
			1.58	II	8580	(38200)				1.58	II	9070	(40300)				
			2.49	III	15600	(69400)				2.49	III	15700	(69600)				
			2.49	III	21800	(97100)				2.49	III	21900	(97500)				
			2.49	III	21900	(97500)				2.49	III	22000	(97800)				
7.02	16600	(1880)	0.87	-	8030	(35700)	8.47	13800	(1560)	0.87	-	8710	(38700)	2	4B120	207	
			1.08	I	8030	(35700)				1.08	I	8710	(38700)				
			1.37	I	8030	(35700)				1.37	I	8710	(38700)				
			1.48	II	15400	(68600)				1.48	II	15600	(69600)				
			2.49	III	15400	(68600)				2.49	III	15600	(69600)				
			2.49	III	21700	(96700)				2.49	III	21900	(97200)				
5.84	20000	(2260)	1.01	I	6930	(30800)	7.04	16600	(1880)	1.01	I	8040	(35800)	2	4B140	249	
			1.14	I	6930	(30800)				1.14	I	8040	(35800)				
			1.48	II	15100	(67100)				1.48	II	15400	(68600)				
			1.48	II	21600	(95900)				1.48	II	21700	(96700)				
			1.48	II	21600	(95900)				1.48	II	21700	(96700)				
			1.48	II	21600	(95900)				1.48	II	21700	(96700)				
4.76	24500	(2770)	0.93	-	4640	(20600)	5.75	20300	(2300)	0.93	-	6810	(30300)	2	4B140	305	
			1.01	I	14500	(64500)				1.01	I	15000	(66900)				
			1.48	II	14500	(64500)				1.48	II	15000	(66900)				
			1.48	II	21300	(94600)				1.48	II	21500	(95800)				
			1.48	II	21300	(94600)				1.48	II	21500	(95800)				
			1.48	II	21300	(94600)				1.48	II	21500	(95800)				

Notes: [1] For double reduction and 1/8 HP single reduction Y4 ratings, refer to selection tables on pages 2.91 thru 2.130.  
[2] Variable Frequency Drive (VFD) notes (see page 2.8 for Constant Torque Speed Ranges):

# Y4 Mounting Single Reduction Selection Tables

**2 HP  
(1.5 kW)**

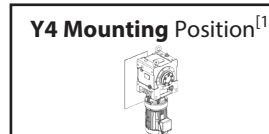

Dimension Pages:  
Single Reduction 2.132-2.143  
Single Reduction, Y2 2.144  
Double Reduction 2.146-2.161  
Double Reduction, Y2 2.162

Frequency	50 Hz	60 Hz
Input Speed	1450 RPM	1750 RPM
Number of Poles	4	

50Hz					60 Hz					Selection							
Output Speed (RPM)	Output Torque		Service Factor		Solid Shaft Overhung Load		Output Speed (RPM)	Output Torque		Service Factor <sup>[1]</sup>		Solid Shaft Overhung Load		Base			VFD <sup>[1]</sup>
	in-lbs	(N·m)	SF	AGMA Class	lbs	(N)		in-lbs	(N·m)	SF	AGMA Class	lbs	(N)	Motor Power Code	Frame Size	Ratio	
11.8	9880	(1120)	0.80	-	4100	(18300)	14.3	8180	(925)	0.80	-	4840	(21500)	2	4A105	123	
			1.00	I	4100	(18300)				1.00	I	4840	(21500)				
			1.16	I	4100	(18300)				1.16	I	4840	(21500)				
			1.58	II	9390	(41800)				1.66	II	9600	(42700)				
			1.92	II	9390	(41800)				2.12	III	9600	(42700)				
			2.30	III	9390	(41800)				2.30	III	9600	(42700)				
9.63	12100	(1370)	0.87	-	2480	(11000)	11.6	10100	(1140)	0.87	-	4010	(17800)	2	4A110	151	
			0.94	-	2480	(11000)				0.94	-	4010	(17800)				
			1.28	I	9030	(40200)				1.28	I	9360	(41600)				
			1.56	II	9030	(40200)				1.59	II	9360	(41600)				
			1.87	II	9030	(40200)				1.87	II	9360	(41600)				
			2.49	III	15700	(69900)				2.49	III	15000	(66700)				
8.12	14400	(1630)	1.09	I	8580	(38200)	9.80	11900	(1350)	1.14	I	9070	(40300)	2	4B120	179	
			1.32	I	8580	(38200)				1.52	II	9070	(40300)				
			1.58	II	8580	(38200)				1.58	II	9070	(40300)				
			2.49	III	15600	(69400)				2.49	III	15700	(69600)				
			2.49	III	21800	(97100)				2.49	III	21900	(97500)				
			2.49	III	21900	(97500)				2.49	III	22000	(97800)				
7.02	16600	(1880)	0.87	-	8030	(35700)	8.47	13800	(1560)	0.87	-	8710	(38700)	2	4B120	207	
			1.08	I	8030	(35700)				1.08	I	8710	(38700)				
			1.37	I	8030	(35700)				1.37	I	8710	(38700)				
			1.48	II	15400	(68600)				1.48	II	15600	(69600)				
			2.49	III	15400	(68600)				2.49	III	15600	(69600)				
			2.49	III	21700	(96700)				2.49	III	21900	(97200)				
5.84	20000	(2260)	1.01	I	6930	(30800)	7.04	16600	(1880)	1.01	I	8040	(35800)	2	4B140	249	
			1.14	I	6930	(30800)				1.14	I	8040	(35800)				
			1.48	II	15100	(67100)				1.48	II	15400	(68600)				
			1.48	II	21600	(95900)				1.48	II	21700	(96700)				
			1.48	II	21600	(95900)				1.48	II	21700	(96700)				
			1.48	II	21600	(95900)				1.48	II	21700	(96700)				
4.76	24500	(2770)	0.93	-	4640	(20600)	5.75	20300	(2300)	0.93	-	6810	(30300)	2	4B140	305	
			1.01	I	14500	(64500)				1.01	I	15000	(66900)				
			1.48	II	14500	(64500)				1.48	II	15000	(66900)				
			1.48	II	21300	(94600)				1.48	II	21500	(95800)				
			1.48	II	21300	(94600)				1.48	II	21500	(95800)				
			1.48	II	21300	(94600)				1.48	II	21500	(95800)				

Notes: [1] For double reduction and 1/8 HP single reduction Y4 ratings, refer to selection tables on pages 2.91 thru 2.130.  
[2] Variable Frequency Drive (VFD) notes (see page 2.8 for Constant Torque Speed Ranges):

# Y4 Mounting Single Reduction Selection Tables

**3 HP  
(2.2 kW)**



Dimension Pages:  
 Single Reduction 2.132-2.143  
 Single Reduction, Y2 2.144  
 Double Reduction 2.146-2.161  
 Double Reduction, Y2 2.162

Frequency	50 Hz	60 Hz
Input Speed	1450 RPM	1750 RPM
Number of Poles	4	

50Hz					60 Hz					Selection							
Output Speed (RPM)	Output Torque		Service Factor		Solid Shaft Overhung Load		Output Speed (RPM)	Output Torque		Service Factor <sup>[1]</sup>		Solid Shaft Overhung Load		Base			VFD <sup>[1]</sup>
	in-lbs	(N·m)	SF	AGMA Class	lbs	(N)		in-lbs	(N·m)	SF	AGMA Class	lbs	(N)	Motor Power Code	Frame Size	Ratio	
69.0	2480	(281)	1.07	I	4700	(20900)	83.3	2060	(232)	1.07	I	4480	(19900)	3	<b>4A100</b>	21	
			1.45	II	4700	(20900)				1.45	II	4480	(19900)	3	<b>4A105</b>	21	
			1.61	II	4700	(20900)				1.61	II	4480	(19900)	3	<b>4A110</b>	21	
			1.78	II	4700	(20900)				1.78	II	4480	(19900)	3	<b>4A115</b>	21	
			2.30	III	4700	(20900)				2.30	III	4480	(19900)	3	<b>4A120</b>	21	
			3.16	III	4700	(20900)				2.64	III	4480	(19900)	3	<b>4A125</b>	21	
			3.16	III	6530	(29100)				2.64	III	6200	(27600)	3	<b>4B125</b>	21	
64.7	2650	(299)	2.30	III	4780	(21200)	78.1	2190	(248)	2.30	III	4560	(20300)	3	<b>4A120</b>	22	
			3.16	III	4780	(21200)				3.16	III	4560	(20300)	3	<b>4A125</b>	22	
			3.16	III	6650	(29600)				3.16	III	6320	(28100)	3	<b>4B125</b>	22	
59.2	2900	(327)	2.30	III	4880	(21700)	71.4	2400	(271)	2.30	III	4660	(20700)	3	<b>4A120</b>	25	
			3.16	III	4880	(21700)				3.16	III	4660	(20700)	3	<b>4A125</b>	25	
			3.16	III	6810	(30300)				3.16	III	6470	(28800)	3	<b>4B125</b>	25	
51.8	3310	(374)	1.07	I	5040	(22400)	62.5	2740	(310)	1.07	I	4820	(21400)	3	<b>4A100</b>	28	
			1.45	II	5040	(22400)				1.45	II	4820	(21400)	3	<b>4A105</b>	28	
			1.61	II	5040	(22400)				1.61	II	4820	(21400)	3	<b>4A110</b>	28	
			1.78	II	5040	(22400)				1.78	II	4820	(21400)	3	<b>4A115</b>	28	
			2.30	III	5040	(22400)				2.30	III	4820	(21400)	3	<b>4A120</b>	28	
			3.16	III	5040	(22400)				3.16	III	4820	(21400)	3	<b>4A125</b>	28	
			3.16	III	7060	(31400)				3.16	III	6710	(29800)	3	<b>4B125</b>	28	
41.2	4160	(470)	1.07	I	5320	(23600)	49.7	3450	(390)	1.07	I	5090	(22600)	3	<b>4A100</b>	35	
			1.45	II	5320	(23600)				1.45	II	5090	(22600)	3	<b>4A105</b>	35	
			1.61	II	5320	(23600)				1.61	II	5090	(22600)	3	<b>4A110</b>	35	
			1.78	II	5320	(23600)				1.78	II	5090	(22600)	3	<b>4A115</b>	35	
			2.30	III	5320	(23600)				2.30	III	5090	(22600)	3	<b>4A120</b>	35	
			2.69	III	5320	(23600)				2.69	III	5090	(22600)	3	<b>4A125</b>	35	
			2.74	III	5320	(23600)				2.74	III	5090	(22600)	3	<b>4A140</b>	35	
			2.69	III	7490	(33300)				2.69	III	7130	(31700)	3	<b>4B125</b>	35	
37.7	4550	(514)	1.07	I	5420	(24100)	45.5	3770	(426)	1.07	I	5200	(23100)	3	<b>4A100</b>	39	
			1.45	II	5420	(24100)				1.45	II	5200	(23100)	3	<b>4A105</b>	39	
			1.61	II	5420	(24100)				1.61	II	5200	(23100)	3	<b>4A110</b>	39	
			1.78	II	5420	(24100)				1.78	II	5200	(23100)	3	<b>4A115</b>	39	
			2.30	III	5420	(24100)				2.30	III	5200	(23100)	3	<b>4A120</b>	39	
			2.51	III	5420	(24100)				2.51	III	5200	(23100)	3	<b>4A125</b>	39	
			2.69	III	7660	(34100)				2.69	III	7300	(32500)	3	<b>4B125</b>	39	

Notes: [1] For double reduction and 1/8 HP single reduction Y4 ratings, refer to selection tables on pages 2.91 thru 2.130.  
 [2] Variable Frequency Drive (VFD) notes (see page 2.8 for Constant Torque Speed Ranges):

# Y4 Mounting Single Reduction Selection Tables

**3 HP  
(2.2 kW)**



Dimension Pages:  
 Single Reduction 2.132-2.143  
 Single Reduction, Y2 2.144  
 Double Reduction 2.146-2.161  
 Double Reduction, Y2 2.162

Frequency	50 Hz	60 Hz
Input Speed	1450 RPM	1750 RPM
Number of Poles	4	

50Hz					60 Hz					Selection							
Output Speed (RPM)	Output Torque		Service Factor		Solid Shaft Overhung Load		Output Speed (RPM)	Output Torque		Service Factor <sup>[1]</sup>		Solid Shaft Overhung Load		Base			VFD <sup>[1]</sup>
	in-lbs	(N·m)	SF	AGMA Class	lbs	(N)		in-lbs	(N·m)	SF	AGMA Class	lbs	(N)	Motor Power Code	Frame Size	Ratio	
31.9	5380	(608)	1.07	I	5620	(25000)	38.5	4460	(504)	1.07	I	5400	(24000)	3	<b>4A100</b>	46	
			1.45	II	5620	(25000)				1.45	II	5400	(24000)	3	<b>4A105</b>	46	
			1.61	II	5620	(25000)				1.61	II	5400	(24000)	3	<b>4A110</b>	46	
			1.77	II	5620	(25000)				1.77	II	5400	(24000)	3	<b>4A115</b>	46	
			2.12	III	5620	(25000)				2.12	III	5400	(24000)	3	<b>4A120</b>	46	
			2.30	III	7990	(35600)				2.30	III	7620	(33900)	3	<b>4B120</b>	46	
			2.69	III	7990	(35600)				2.69	III	7620	(33900)	3	<b>4B125</b>	46	
27.6	6210	(701)	1.07	I	5440	(24200)	33.3	5140	(581)	1.07	I	5570	(24800)	3	<b>4A100</b>	53	
			1.45	II	5440	(24200)				1.45	II	5570	(24800)	3	<b>4A105</b>	53	
			1.61	II	5440	(24200)				1.61	II	5570	(24800)	3	<b>4A110</b>	53	
			1.77	II	5440	(24200)				1.77	II	5570	(24800)	3	<b>4A115</b>	53	
			1.84	II	5440	(24200)				1.84	II	5570	(24800)	3	<b>4A120</b>	53	
			2.30	III	8280	(36800)				2.30	III	7900	(35200)	3	<b>4B120</b>	53	
24.4	7040	(795)	0.90	-	5210	(23200)	29.4	5830	(659)	0.90	-	5530	(24600)	3	<b>4A100</b>	60	
			1.12	I	5210	(23200)				1.12	I	5530	(24600)	3	<b>4A105</b>	60	
			1.44	II	5210	(23200)				1.44	II	5530	(24600)	3	<b>4A110</b>	60	
			1.62	II	5210	(23200)				1.62	II	5530	(24600)	3	<b>4A115</b>	60	
			2.22	III	8530	(38000)				2.22	III	8150	(36300)	3	<b>4B120</b>	60	
			2.57	III	8530	(38000)				2.57	III	8150	(36300)	3	<b>4B125</b>	60	
			2.53	III	12100	(53900)				2.53	III	11500	(51200)	3	<b>4C140</b>	60	
21.6	7950	(898)	0.86	-	4920	(21900)	26.0	6580	(744)	0.86	-	5340	(23800)	3	<b>4A100</b>	67	
			1.04	I	4920	(21900)				1.06	I	5340	(23800)	3	<b>4A105</b>	67	
			1.24	I	4920	(21900)				1.24	I	5340	(23800)	3	<b>4A110</b>	67	
			1.41	II	4920	(21900)				1.41	II	5340	(23800)	3	<b>4A115</b>	67	
			1.44	II	4920	(21900)				1.44	II	5340	(23800)	3	<b>4A120</b>	67	
			1.80	II	8780	(39100)				1.80	II	8400	(37400)	3	<b>4B120</b>	67	
			2.18	III	8780	(39100)				2.22	III	8400	(37400)	3	<b>4B125</b>	67	
			2.53	III	8780	(39100)				2.53	III	8400	(37400)	3	<b>4B140</b>	67	
			2.86	III	8780	(39100)				2.86	III	8400	(37400)	3	<b>4B160</b>	67	
19.7	8690	(982)	0.86	-	4650	(20700)	23.8	7200	(814)	0.86	-	5170	(23000)	3	<b>4A100</b>	74	
			1.04	I	4650	(20700)				1.06	I	5170	(23000)	3	<b>4A105</b>	74	
			1.24	I	4650	(20700)				1.24	I	5170	(23000)	3	<b>4A110</b>	74	
			1.31	I	4650	(20700)				1.31	I	5170	(23000)	3	<b>4A115</b>	74	
			1.80	II	8960	(39900)				1.80	II	8580	(38200)	3	<b>4B120</b>	74	
			2.18	III	8960	(39900)				2.22	III	8580	(38200)	3	<b>4B125</b>	74	
			2.53	III	8960	(39900)				2.53	III	8580	(38200)	3	<b>4B140</b>	74	
			2.62	III	8960	(39900)				2.62	III	8580	(38200)	3	<b>4B160</b>	74	

Notes: [1] For double reduction and 1/8 HP single reduction Y4 ratings, refer to selection tables on pages 2.91 thru 2.130.  
 [2] Variable Frequency Drive (VFD) notes (see page 2.8 for Constant Torque Speed Ranges):



# Y4 Mounting Single Reduction Selection Tables

**3 HP  
(2.2 kW)**



Dimension Pages:  
Single Reduction 2.132-2.143  
Single Reduction, Y2 2.144  
Double Reduction 2.146-2.161  
Double Reduction, Y2 2.162

Frequency	50 Hz	60 Hz
Input Speed	1450 RPM	1750 RPM
Number of Poles	4	

50Hz					60 Hz					Selection							
Output Speed (RPM)	Output Torque		Service Factor		Solid Shaft Overhung Load		Output Speed (RPM)	Output Torque		Service Factor <sup>[1]</sup>		Solid Shaft Overhung Load		Base			VFD <sup>[1]</sup>
	in-lbs	(N·m)	SF	AGMA Class	lbs	(N)		in-lbs	(N·m)	SF	AGMA Class	lbs	(N)	Motor Power Code	Frame Size	Ratio	
18.1	9460	(1070)	0.76	-	4310	(19200)	21.9	7840	(886)	0.76	-	4960	(22100)	3	<b>4A105</b>	80	
			0.87	-	4310	(19200)				0.87	-	4960	(22100)	3	<b>4A110</b>	80	
			1.01	I	4310	(19200)				1.01	I	4960	(22100)	3	<b>4A115</b>	80	
			1.21	I	4310	(19200)				1.21	I	4960	(22100)	3	<b>4A120</b>	80	
			1.40	II	9140	(40600)				1.40	II	8750	(38900)	3	<b>4B120</b>	80	
			1.80	II	9140	(40600)				1.80	II	8750	(38900)	3	<b>4B125</b>	80	
			2.40	III	9140	(40600)				2.40	III	8750	(38900)	3	<b>4B140</b>	80	
			2.53	III	13100	(58100)				2.53	III	12500	(55400)	3	<b>4C140</b>	80	
16.6	10300	(1170)	0.76	-	3850	(17100)	20.0	8570	(969)	0.76	-	4690	(20900)	3	<b>4A105</b>	88	
			0.87	-	3850	(17100)				0.87	-	4690	(20900)	3	<b>4A110</b>	88	
			1.01	I	3850	(17100)				1.01	I	4690	(20900)	3	<b>4A115</b>	88	
			1.10	I	3850	(17100)				1.10	I	4690	(20900)	3	<b>4A120</b>	88	
			1.40	II	9320	(41400)				1.40	II	8940	(39800)	3	<b>4B120</b>	88	
			1.80	II	9320	(41400)				1.80	II	8940	(39800)	3	<b>4B125</b>	88	
			2.20	III	9320	(41400)				2.20	III	8940	(39800)	3	<b>4B140</b>	88	
			2.53	III	13400	(59400)				2.53	III	12700	(56700)	3	<b>4C140</b>	88	
14.3	12000	(1360)	0.87	-	2610	(11600)	17.2	9940	(1120)	0.87	-	4070	(18100)	3	<b>4A110</b>	102	
			0.95	-	2610	(11600)				0.95	-	4070	(18100)	3	<b>4A115</b>	102	
			1.30	I	9050	(40300)				1.36	I	9240	(41100)	3	<b>4B120</b>	102	
			1.58	II	9050	(40300)				1.71	II	9240	(41100)	3	<b>4B125</b>	102	
			1.90	II	9050	(40300)				1.90	II	9240	(41100)	3	<b>4B160</b>	102	
12.9	13200	(1500)	0.82	-	290	(1290)	15.6	11000	(1240)	0.82	-	3450	(15400)	3	<b>4A115</b>	112	
			0.86	-	290	(1290)				0.86	-	3450	(15400)	3	<b>4A120</b>	112	
			1.08	I	8820	(39200)				1.13	I	9220	(41000)	3	<b>4B120</b>	112	
			1.31	I	8820	(39200)				1.45	II	9220	(41000)	3	<b>4B125</b>	112	
			1.70	II	8820	(39200)				1.70	II	9220	(41000)	3	<b>4B140</b>	112	
			1.72	II	8820	(39200)				1.72	II	9220	(41000)	3	<b>4B160</b>	112	
11.8	14500	(1640)	1.08	I	8560	(38100)	14.3	12000	(1360)	1.13	I	9050	(40300)	3	<b>4B120</b>	123	
			1.31	I	8560	(38100)				1.45	II	9050	(40300)	3	<b>4B125</b>	123	
			1.57	II	8560	(38100)				1.57	II	9050	(40300)	3	<b>4B140</b>	123	
			1.70	II	14500	(64500)				1.70	II	13900	(61600)	3	<b>4C140</b>	123	
			3.14	III	14500	(64500)				3.14	III	13900	(61600)	3	<b>4C160</b>	123	
9.63	17800	(2010)	0.87	-	7690	(34200)	11.6	14700	(1670)	0.87	-	8500	(37800)	3	<b>4B120</b>	151	
			1.06	I	7690	(34200)				1.08	I	8500	(37800)	3	<b>4B125</b>	151	
			1.28	I	7690	(34200)				1.28	I	8500	(37800)	3	<b>4B160</b>	151	
			1.70	II	15200	(67600)				1.70	II	14600	(64700)	3	<b>4C160</b>	151	
			2.56	III	15200	(67600)				2.56	III	14600	(64700)	3	<b>4C170</b>	151	

Notes: [1] For double reduction and 1/8 HP single reduction Y4 ratings, refer to selection tables on pages 2.91 thru 2.130.  
[2] Variable Frequency Drive (VFD) notes (see page 2.8 for Constant Torque Speed Ranges):

# Y4 Mounting Single Reduction Selection Tables

**3 HP  
(2.2 kW)**



Dimension Pages:  
Single Reduction 2.132-2.143  
Single Reduction, Y2 2.144  
Double Reduction 2.146-2.161  
Double Reduction, Y2 2.162

Frequency	50 Hz	60 Hz
Input Speed	1450 RPM	1750 RPM
Number of Poles	4	

50Hz					60 Hz					Selection							
Output Speed (RPM)	Output Torque		Service Factor		Solid Shaft Overhung Load		Output Speed (RPM)	Output Torque		Service Factor <sup>[1]</sup>		Solid Shaft Overhung Load		Base			VFD <sup>[1]</sup>
	in-lbs	(N·m)	SF	AGMA Class	lbs	(N)		in-lbs	(N·m)	SF	AGMA Class	lbs	(N)	Motor Power Code	Frame Size	Ratio	
8.12	21100	(2380)	0.74	-	6500	(28900)	9.80	17500	(1980)	0.78	-	7790	(34600)	3	<b>4B120</b>	179	
			0.90	-	6500	(28900)				1.04	I	7790	(34600)	3	<b>4B125</b>	179	
			1.08	I	6500	(28900)				1.08	I	7790	(34600)	3	<b>4B160</b>	179	
			1.70	II	15000	(66500)				1.70	II	15100	(67300)	3	<b>4C160</b>	179	
			2.16	III	15000	(66500)				2.16	III	15100	(67300)	3	<b>4C170</b>	179	
			7.02	24400	(2760)	0.93				-	4730	(21000)	8.47	20200	(2290)	0.93	
1.01	I	14500	(64600)	1.01	I	15100	(67000)	3	<b>4C140</b>	207							
1.70	II	14500	(64600)	1.70	II	15100	(67000)	3	<b>4C160</b>	207							
1.86	II	14500	(64600)	1.86	II	15100	(67000)	3	<b>4C170</b>	207							
5.84	29400	(3320)	1.01	I	13700	(61100)	7.04	24300	(2750)	1.01	I	14500	(64700)	3	<b>4C160</b>	249	
			1.55	II	13700	(61100)				1.55	II	14500	(64700)	3	<b>4C170</b>	249	
			1.70	II	20900	(93000)				1.70	II	21300	(94700)	3	<b>4D170</b>	249	
			2.53	III	20900	(93000)				2.53	III	21300	(94700)	3	<b>4D180</b>	249	
			2.53	III	22300	(99300)				2.53	III	22600	(100000)	3	<b>4E180</b>	249	
4.76	36000	(4070)	1.01	I	12400	(55000)	5.75	29800	(3370)	1.01	I	13700	(60800)	3	<b>4C160</b>	305	
			1.26	I	12400	(55000)				1.26	I	13700	(60800)	3	<b>4C170</b>	305	
			1.70	II	20300	(90200)				1.70	II	20900	(92800)	3	<b>4D170</b>	305	
			2.14	III	20300	(90200)				2.53	III	20900	(92800)	3	<b>4D180</b>	305	
			2.53	III	22000	(97800)				2.53	III	22300	(99200)	3	<b>4E180</b>	305	

Notes: [1] For double reduction and 1/8 HP single reduction Y4 ratings, refer to selection tables on pages 2.91 thru 2.130.  
[2] Variable Frequency Drive (VFD) notes (see page 2.8 for Constant Torque Speed Ranges):

# Y4 Mounting Single Reduction Selection Tables

**5 HP  
(3.7 kW)**



Dimension Pages:

Single Reduction	2.132-2.143
Single Reduction, Y2	2.144
Double Reduction	2.146-2.161
Double Reduction, Y2	2.162

Frequency	50 Hz	60 Hz
Input Speed	1450 RPM	1750 RPM
Number of Poles	4	

50Hz					60 Hz					Selection							
Output Speed (RPM)	Output Torque		Service Factor		Solid Shaft Overhung Load		Output Speed (RPM)	Output Torque		Service Factor <sup>[1]</sup>		Solid Shaft Overhung Load		Base			VFD <sup>[1]</sup>
	in-lbs	(N·m)	SF	AGMA Class	lbs	(N)		in-lbs	(N·m)	SF	AGMA Class	lbs	(N)	Motor Power Code	Frame Size	Ratio	
69.0	4180	(472)	1.06	I	4470	(19900)	83.3	3460	(391)	1.06	I	4290	(19100)	5	<b>4A115</b>	21	
			1.37	I	4470	(19900)				1.37	I	4290	(19100)	5	<b>4A120</b>	21	
			1.88	II	4470	(19900)				1.57	II	4290	(19100)	5	<b>4A125</b>	21	
			2.73	III	4470	(19900)				2.73	III	4290	(19100)	5	<b>4A140</b>	21	
			1.88	II	6350	(28200)				1.57	II	6050	(26900)	5	<b>4B125</b>	21	
			3.00	III	6350	(28200)				3.00	III	6050	(26900)	5	<b>4B140</b>	21	
			3.00	III	8950	(39800)				3.00	III	8510	(37800)	5	<b>4C140</b>	21	
64.7	4450	(503)	1.37	I	4530	(20100)	78.1	3690	(417)	1.37	I	4350	(19400)	5	<b>4A120</b>	22	
			1.88	II	4530	(20100)				1.88	II	4350	(19400)	5	<b>4A125</b>	22	
			2.56	III	4530	(20100)				2.56	III	4350	(19400)	5	<b>4A140</b>	22	
			1.88	II	6450	(28700)				1.88	II	6150	(27400)	5	<b>4B125</b>	22	
			3.00	III	6450	(28700)				3.00	III	6150	(27400)	5	<b>4B140</b>	22	
			3.00	III	9110	(40500)				3.00	III	8660	(38500)	5	<b>4C140</b>	22	
			59.2	4870	(550)	1.37				I	4610	(20500)	71.4	4040	(456)	1.37	
1.88	II	4610				(20500)	1.88	II	4440	(19700)	5	<b>4A125</b>				25	
2.34	III	4610				(20500)	2.34	III	4440	(19700)	5	<b>4A140</b>				25	
1.88	II	6600				(29300)	1.88	II	6300	(28000)	5	<b>4B125</b>				25	
3.00	III	6600				(29300)	3.00	III	6300	(28000)	5	<b>4B140</b>				25	
3.00	III	9330				(41500)	3.00	III	8870	(39500)	5	<b>4C140</b>				25	
51.8	5570	(629)				1.06	I	4730	(21100)	62.5	4610	(521)				1.06	I
			1.37	I	4730	(21100)	1.37	I	4560				(20300)	5	<b>4A120</b>	28	
			1.88	II	4730	(21100)	1.88	II	4560				(20300)	5	<b>4A125</b>	28	
			2.05	III	4730	(21100)	2.05	III	4560				(20300)	5	<b>4A140</b>	28	
			1.88	II	6810	(30300)	1.88	II	6510				(28900)	5	<b>4B125</b>	28	
			3.00	III	6810	(30300)	3.00	III	6510				(28900)	5	<b>4B140</b>	28	
			3.00	III	9660	(43000)	3.00	III	9190				(40900)	5	<b>4C140</b>	28	
41.2	7000	(791)	1.06	I	4930	(21900)	49.7	5800	(655)	1.06	I	4770	(21200)	5	<b>4A115</b>	35	
			1.37	I	4930	(21900)				1.37	I	4770	(21200)	5	<b>4A120</b>	35	
			1.60	II	4930	(21900)				1.60	II	4770	(21200)	5	<b>4A125</b>	35	
			1.63	II	4930	(21900)				1.63	II	4770	(21200)	5	<b>4A140</b>	35	
			1.60	II	7180	(32000)				1.60	II	6880	(30600)	5	<b>4B125</b>	35	
			3.00	III	7180	(32000)				3.00	III	6880	(30600)	5	<b>4B140</b>	35	
			3.00	III	10200	(45600)				3.00	III	9760	(43400)	5	<b>4C140</b>	35	

Notes: [1] For double reduction and 1/8 HP single reduction Y4 ratings, refer to selection tables on pages 2.91 thru 2.130.  
[2] Variable Frequency Drive (VFD) notes (see page 2.8 for Constant Torque Speed Ranges):

# Y4 Mounting Single Reduction Selection Tables

**5 HP  
(3.7 kW)**

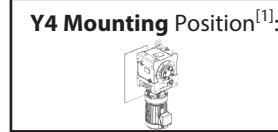

Dimension Pages:

Single Reduction	2.132-2.143
Single Reduction, Y2	2.144
Double Reduction	2.146-2.161
Double Reduction, Y2	2.162

Frequency	50 Hz	60 Hz
Input Speed	1450 RPM	1750 RPM
Number of Poles	4	

50Hz					60 Hz					Selection								
Output Speed (RPM)	Output Torque		Service Factor		Solid Shaft Overhung Load		Output Speed (RPM)	Output Torque		Service Factor <sup>[1]</sup>		Solid Shaft Overhung Load		Base			VFD <sup>[1]</sup>	
	in-lbs	(N·m)	SF	AGMA Class	lbs	(N)		in-lbs	(N·m)	SF	AGMA Class	lbs	(N)	Motor Power Code	Frame Size	Ratio		
37.7	7660	(865)	1.06	I	5000	(22200)	45.5	6340	(717)	1.06	I	4850	(21600)	5	<b>4A115</b>	39		
			1.37	I	5000	(22200)				1.37	I	4850	(21600)	5	<b>4A120</b>	39		
			1.49	II	5000	(22200)				1.49	II	4850	(21600)	5	<b>4A125</b>	39		
			1.60	II	7330	(32600)				1.60	II	7020	(31200)	5	<b>4B125</b>	39		
			2.97	III	7330	(32600)				2.97	III	7020	(31200)	5	<b>4B140</b>	39		
			3.00	III	10500	(46600)				3.00	III	9990	(44500)	5	<b>4C140</b>	39		
			31.9	9050	(1020)	1.05				I	4500	(20000)	38.5	7500	(847)	1.05		I
1.26	I	4500				(20000)	1.26	I	4980	(22200)	5	<b>4A120</b>				46		
1.37	I	7600				(33800)	1.37	I	7300	(32500)	5	<b>4B120</b>				46		
1.60	II	7600				(33800)	1.60	II	7300	(32500)	5	<b>4B125</b>				46		
2.05	III	7600				(33800)	2.05	III	7300	(32500)	5	<b>4B140</b>				46		
2.51	III	7600				(33800)	2.51	III	7300	(32500)	5	<b>4B160</b>				46	(-)	
3.00	III	10900				(48600)	3.00	III	10400	(46400)	5	<b>4C160</b>				46	(-)	
27.6	10400	(1180)	1.05	I	3790	(16900)	33.3	8650	(977)	1.05	I	4660	(20700)	5	<b>4A115</b>	53		
			1.09	I	3790	(16900)				1.09	I	4660	(20700)	5	<b>4A120</b>	53		
			1.37	I	7820	(34800)				1.37	I	7530	(33500)	5	<b>4B120</b>	53		
			1.60	II	7820	(34800)				1.60	II	7530	(33500)	5	<b>4B125</b>	53		
			2.05	III	7820	(34800)				2.05	III	7530	(33500)	5	<b>4B140</b>	53		
			2.18	III	7820	(34800)				2.18	III	7530	(33500)	5	<b>4B160</b>	53		
			3.00	III	11300	(50300)				3.00	III	10800	(48100)	5	<b>4C160</b>	53		
24.4	11800	(1340)	0.96	-	2780	(12300)	29.4	9800	(1110)	0.96	-	4140	(18400)	5	<b>4A115</b>	60		
			1.32	I	8020	(35700)				1.32	I	7730	(34400)	5	<b>4B120</b>	60		
			1.53	II	8020	(35700)				1.53	II	7730	(34400)	5	<b>4B125</b>	60		
			1.92	II	8020	(35700)				1.92	II	7730	(34400)	5	<b>4B160</b>	60		
			3.00	III	11700	(51800)				3.00	III	11100	(49600)	5	<b>4C160</b>	60		
			3.00	III	17500	(77800)				3.00	III	16600	(74000)	5	<b>4D160</b>	60		
			2.62	III	22800	(101000)				2.62	III	21600	(96300)	5	<b>4E170</b>	60		
21.6	13400	(1510)	1.07	I	8200	(36500)	26.0	11100	(1250)	1.07	I	7910	(35200)	5	<b>4B120</b>	67		
			1.30	I	8200	(36500)				1.32	I	7910	(35200)	5	<b>4B125</b>	67		
			1.50	II	8200	(36500)				1.50	II	7910	(35200)	5	<b>4B140</b>	67		
			1.70	II	8200	(36500)				1.70	II	7910	(35200)	5	<b>4B160</b>	67		
			2.05	III	12000	(53300)				2.05	III	11500	(51000)	5	<b>4C160</b>	67		
			2.62	III	12000	(53300)				2.62	III	11500	(51000)	5	<b>4C170</b>	67		
			2.62	III	18000	(80300)				2.62	III	17200	(76400)	5	<b>4D170</b>	67		
2.62	III	23100	(103000)	2.62	III	22400	(99600)	5	<b>4E170</b>	67								

Notes: [1] For double reduction and 1/8 HP single reduction Y4 ratings, refer to selection tables on pages 2.91 thru 2.130.  
[2] Variable Frequency Drive (VFD) notes (see page 2.8 for Constant Torque Speed Ranges):

# Y4 Mounting Single Reduction Selection Tables

**5 HP  
(3.7 kW)**



Dimension Pages:

Single Reduction	2.132-2.143
Single Reduction, Y2	2.144
Double Reduction	2.146-2.161
Double Reduction, Y2	2.162

Frequency	50 Hz	60 Hz
Input Speed	1450 RPM	1750 RPM
Number of Poles	4	

50Hz				60 Hz				Selection										
Output Speed (RPM)	Output Torque		Service Factor	Solid Shaft Overhung Load		Output Speed (RPM)	Output Torque		Service Factor <sup>[1]</sup>	Solid Shaft Overhung Load		Base			VFD <sup>[1]</sup>			
	in-lbs	(N·m)		lbs	(N)		in-lbs	(N·m)		lbs	(N)	Motor Power Code	Frame Size	Ratio				
19.7	14600	(1650)	1.07	I	8320	(37000)	23.8	12100	(1370)	1.07	I	8050	(35800)	5	<b>4B120</b>	74		
			1.30	I	8320	(37000)				1.32	I	8050	(35800)	5	<b>4B125</b>	74		
			1.50	II	8320	(37000)				1.50	II	8050	(35800)	5	<b>4B140</b>	74		
			1.56	II	8320	(37000)				1.56	II	8050	(35800)	5	<b>4B160</b>	74		
			2.05	III	12200	(54400)				2.05	III	11700	(52100)	5	<b>4C160</b>	74		
			2.62	III	12200	(54400)				2.62	III	11700	(52100)	5	<b>4C170</b>	74		
			2.62	III	18500	(82100)				2.62	III	17600	(78200)	5	<b>4D170</b>	74		
			2.62	III	23100	(103000)				2.62	III	22900	(102000)	5	<b>4E170</b>	74		
18.1	15900	(1800)	0.83	-	8220	(36600)	21.9	13200	(1490)	0.83	-	8180	(36400)	5	<b>4B120</b>	80		
			1.07	I	8220	(36600)				1.07	I	8180	(36400)	5	<b>4B125</b>	80		
			1.43	II	8220	(36600)				1.43	II	8180	(36400)	5	<b>4B140</b>	80		
			1.50	II	12500	(55400)				1.50	II	11900	(53100)	5	<b>4C140</b>	80		
			2.05	III	12500	(55400)				2.05	III	11900	(53100)	5	<b>4C160</b>	80		
			2.86	III	12500	(55400)				2.86	III	11900	(53100)	5	<b>4C170</b>	80		(-)
			3.00	III	18900	(83900)				3.00	III	18000	(80000)	5	<b>4D170</b>	80		(-)
			3.00	III	23000	(102000)				3.00	III	23100	(103000)	5	<b>4E170</b>	80		(-)
16.6	17400	(1970)	0.83	-	7810	(34700)	20.0	14400	(1630)	0.83	-	8310	(36900)	5	<b>4B120</b>	88		
			1.07	I	7810	(34700)				1.07	I	8310	(36900)	5	<b>4B125</b>	88		
			1.31	I	7810	(34700)				1.31	I	8310	(36900)	5	<b>4B140</b>	88		
			1.50	II	12700	(56500)				1.50	II	12200	(54200)	5	<b>4C140</b>	88		
			2.05	III	12700	(56500)				2.05	III	12200	(54200)	5	<b>4C160</b>	88		
			2.61	III	12700	(56500)				2.61	III	12200	(54200)	5	<b>4C170</b>	88		(-)
			3.00	III	19300	(85800)				3.00	III	18400	(81900)	5	<b>4D170</b>	88		(-)
			3.00	III	22900	(102000)				3.00	III	23100	(103000)	5	<b>4E170</b>	88		(-)
14.3	20200	(2280)	0.77	-	6870	(30600)	17.2	16700	(1890)	0.81	-	8000	(35600)	5	<b>4B120</b>	102		
			0.94	-	6870	(30600)				1.02	I	8000	(35600)	5	<b>4B125</b>	102		
			1.13	I	6870	(30600)				1.13	I	8000	(35600)	5	<b>4B160</b>	102		
			2.05	III	13100	(58200)				2.05	III	12600	(56000)	5	<b>4C160</b>	102		
			2.25	III	13100	(58200)				2.25	III	12600	(56000)	5	<b>4C170</b>	102		(-)
			3.00	III	20000	(89000)				3.00	III	19100	(85000)	5	<b>4D170</b>	102		(-)
			3.00	III	22800	(101000)				3.00	III	23000	(102000)	5	<b>4E170</b>	102		(-)
			2.62	III	31300	(139000)				2.62	III	31400	(140000)	5	<b>4F180</b>	102		(-)

Notes: [1] For double reduction and 1/8 HP single reduction Y4 ratings, refer to selection tables on pages 2.91 thru 2.130.  
[2] Variable Frequency Drive (VFD) notes (see page 2.8 for Constant Torque Speed Ranges):

# Y4 Mounting Single Reduction Selection Tables

**5 HP  
(3.7 kW)**



Dimension Pages:

Single Reduction	2.132-2.143
Single Reduction, Y2	2.144
Double Reduction	2.146-2.161
Double Reduction, Y2	2.162

Frequency	50 Hz	60 Hz
Input Speed	1450 RPM	1750 RPM
Number of Poles	4	

50Hz				60 Hz				Selection																
Output Speed (RPM)	Output Torque		Service Factor	Solid Shaft Overhung Load		Output Speed (RPM)	Output Torque		Service Factor <sup>[1]</sup>	Solid Shaft Overhung Load		Base			VFD <sup>[1]</sup>									
	in-lbs	(N·m)		lbs	(N)		in-lbs	(N·m)		lbs	(N)	Motor Power Code	Frame Size	Ratio										
12.9	22300	(2520)	0.78	-	5960	(26500)	15.6	18500	(2090)	0.86	-	7490	(33300)	5	<b>4B125</b>	112								
			1.01	I	5960	(26500)				1.01	I	7490	(33300)	5	<b>4B140</b>	112								
			1.02	I	5960	(26500)				1.02	I	7490	(33300)	5	<b>4B160</b>	112								
			2.04	III	13300	(59300)				2.04	III	12800	(57100)	5	<b>4C160</b>	112								
			2.05	III	20500	(91200)				2.05	III	19600	(87100)	5	<b>4D160</b>	112								
			2.62	III	20500	(91200)				2.62	III	19600	(87100)	5	<b>4D180</b>	112								
			2.62	III	22700	(101000)				2.62	III	22900	(102000)	5	<b>4E180</b>	112								
			2.62	III	31200	(139000)				2.62	III	31400	(140000)	5	<b>4F180</b>	112								
11.8	24400	(2750)	0.78	-	4760	(21200)	14.3	20200	(2280)	0.86	-	6870	(30600)	5	<b>4B125</b>	123								
			0.93	-	4760	(21200)				0.93	-	6870	(30600)	5	<b>4B140</b>	123								
			1.01	I	13600	(60300)				1.01	I	13100	(58200)	5	<b>4C140</b>	123								
			1.87	II	13600	(60300)				1.87	II	13100	(58200)	5	<b>4C160</b>	123								
			2.05	III	20900	(93100)				2.05	III	20000	(89000)	5	<b>4D160</b>	123								
			2.62	III	20900	(93100)				2.62	III	20000	(89000)	5	<b>4D180</b>	123								
			2.62	III	22600	(100000)				2.62	III	22800	(101000)	5	<b>4E180</b>	123								
			2.62	III	31100	(138000)				2.62	III	31300	(139000)	5	<b>4F180</b>	123								
9.63	29900	(3380)	1.01	I	13600	(60700)	11.6	24800	(2800)	1.01	I	13600	(60500)	5	<b>4C160</b>	151								
			1.52	II	13600	(60700)				1.52	II	13600	(60500)	5	<b>4C170</b>	151								
			2.05	III	20900	(92800)				2.05	III	21000	(93500)	5	<b>4D170</b>	151								
			2.05	III	22300	(99100)				2.05	III	22500	(100000)	5	<b>4E170</b>	151								
			2.62	III	22300	(99100)				2.62	III	22500	(100000)	5	<b>4E190</b>	151								
			2.62	III	30900	(137000)				2.62	III	31100	(138000)	5	<b>4F190</b>	151								
			8.12	35500	(4010)	1.01				I	12500	(55600)	9.80	29400	(3320)	1.01		I	13700	(61100)	5	<b>4C160</b>	179	
						1.28				I	12500	(55600)				1.28		I	13700	(61100)	5	<b>4C170</b>	179	
1.50	II	20300				(90400)	1.50	II	20900	(93000)	5	<b>4D170</b>				179								
1.50	II	22000				(97900)	1.50	II	22300	(99300)	5	<b>4E170</b>				179								
1.92	II	22000				(97900)	1.92	II	22300	(99300)	5	<b>4E190</b>				179								
1.92	II	30600				(136000)	1.92	II	30900	(137000)	5	<b>4F190</b>				179								
7.02	41100	(4640)				1.01	I	11000	(48900)	8.47	34000	(3840)				1.01	I	12800	(57100)	5	<b>4C160</b>	207		
						1.11	I	11000	(48900)							1.11	I	12800	(57100)	5	<b>4C170</b>	207		
			1.50	II	19700	(87500)	1.50	II	20500				(91100)	5	<b>4D170</b>	207								
			1.88	II	19700	(87500)	2.05	III	20500				(91100)	5	<b>4D180</b>	207	(-)							
			2.05	III	21700	(96600)	2.05	III	22100				(98200)	5	<b>4E180</b>	207	(-)							
			2.05	III	30400	(135000)	2.05	III	30700				(137000)	5	<b>4F180</b>	207	(-)							
			5.84	49400	(5580)	1.01	I	18500	(82200)				7.04	40900	(4630)	1.01	I	19700	(87600)	5	<b>4D170</b>	249		
						1.50	II	18500	(82200)							1.50	II	19700	(87600)	5	<b>4D180</b>	249		
1.50	II	21300				(94800)	1.50	II	21700	(96700)	5	<b>4E180</b>				249	(-)							
1.50	II	30000				(134000)	1.50	II	30400	(135000)	5	<b>4F180</b>				249	(-)							

Notes: [1] For double reduction and 1/8 HP single reduction Y4 ratings, refer to selection tables on pages 2.91 thru 2.130.  
[2] Variable Frequency Drive (VFD) notes (see page 2.8 for Constant Torque Speed Ranges):

# Y4 Mounting Single Reduction Selection Tables

**5 HP  
(3.7 kW)**



Dimension Pages:

Single Reduction	2.132-2.143
Single Reduction, Y2	2.144
Double Reduction	2.146-2.161
Double Reduction, Y2	2.162

Frequency	50 Hz	60 Hz
Input Speed	1450 RPM	1750 RPM
Number of Poles	4	

50Hz				60 Hz				Selection										
Output Speed (RPM)	Output Torque		Service Factor	Solid Shaft Overhung Load		Output Speed (RPM)	Output Torque		Service Factor <sup>[1]</sup>	Solid Shaft Overhung Load		Base			VFD <sup>[1]</sup>			
	in-lbs	(N·m)		lbs	(N)		in-lbs	(N·m)		lbs	(N)	Motor Power Code	Frame Size	Ratio				
4.76	60600 (6840)		1.01	I	16400 (72800)	5.75	50200 (5670)		1.01	I	18400 (81700)	5	4D170	305				
			1.27	I	16400 (72800)				1.50	II	18400 (81700)					4D180	305	(-)
			1.50	II	20700 (92200)				1.50	II	21300 (94600)							
			1.50	II	29600 (131000)				1.50	II	30000 (133000)					4F180	305	(-)

# Y4 Mounting Single Reduction Selection Tables

**7.5 HP  
(5.5 kW)**



Dimension Pages:

Single Reduction	2.132-2.143
Single Reduction, Y2	2.144
Double Reduction	2.146-2.161
Double Reduction, Y2	2.162

Frequency	50 Hz	60 Hz
Input Speed	1450 RPM	1750 RPM
Number of Poles	4	

50Hz				60 Hz				Selection									
Output Speed (RPM)	Output Torque		Service Factor	Solid Shaft Overhung Load		Output Speed (RPM)	Output Torque		Service Factor <sup>[1]</sup>	Solid Shaft Overhung Load		Base			VFD <sup>[1]</sup>		
	in-lbs	(N·m)		lbs	(N)		in-lbs	(N·m)		lbs	(N)	Motor Power Code	Frame Size	Ratio			
69.0	6210 (701)		0.92	-	4190 (18600)	83.3	5140 (581)		0.92	-	4060 (18100)	8	4A120	21			
			1.27	I	4190 (18600)				1.06	I	4060 (18100)					4A125	21
			1.84	II	4190 (18600)				1.84	II	4060 (18100)						
			1.27	I	6130 (27300)				1.06	I	5870 (26100)					4B125	21
			2.02	III	6130 (27300)				2.02	III	5870 (26100)						
			2.02	III	8760 (39000)				2.02	III	8350 (37100)					4C140	21
64.7	6620 (748)		0.92	-	4230 (18800)	78.1	5490 (620)		0.92	-	4110 (18300)	8	4A120	22			
			1.27	I	4230 (18800)				1.27	I	4110 (18300)					4A125	22
			1.72	II	4230 (18800)				1.72	II	4110 (18300)						
			1.27	I	6220 (27700)				1.27	I	5960 (26500)					4B125	22
			2.02	III	6220 (27700)				2.02	III	5960 (26500)						
			2.75	III	6220 (27700)				2.75	III	5960 (26500)					4B160	22
			2.75	III	8900 (39600)				2.75	III	8490 (37700)						
			2.75	III	13200 (58800)				2.75	III	12600 (55900)					4D160	22
59.2	7240 (818)		0.92	-	4290 (19100)	71.4	6000 (678)		0.92	-	4170 (18500)	8	4A120	25			
			1.27	I	4290 (19100)				1.27	I	4170 (18500)					4A125	25
			1.58	II	4290 (19100)				1.58	II	4170 (18500)						
			1.27	I	6340 (28200)				1.27	I	6080 (27100)					4B125	25
			2.02	III	6340 (28200)				2.02	III	6080 (27100)						
			2.75	III	6340 (28200)				2.75	III	6080 (27100)					4B160	25
			2.75	III	9100 (40500)				2.75	III	8680 (38600)						
			2.75	III	13500 (60300)				2.75	III	12900 (57200)					4D160	25
51.8	8280 (935)		0.92	-	4360 (19400)	62.5	6860 (775)		0.92	-	4250 (18900)	8	4A120	28			
			1.26	I	4360 (19400)				1.26	I	4250 (18900)					4A125	28
			1.38	I	4360 (19400)				1.38	I	4250 (18900)						
			1.26	I	6520 (29000)				1.26	I	6270 (27900)					4B125	28
			2.02	III	6520 (29000)				2.02	III	6270 (27900)						
			2.75	III	6520 (29000)				2.75	III	6270 (27900)					4B160	28
			2.75	III	9400 (41800)				2.75	III	8980 (39900)						
			2.75	III	14000 (62400)				2.75	III	13300 (59400)					4D160	28

Notes: [1] For double reduction and 1/8 HP single reduction Y4 ratings, refer to selection tables on pages 2.91 thru 2.130.  
[2] Variable Frequency Drive (VFD) notes (see page 2.8 for Constant Torque Speed Ranges):

(-) = For inverter operation, starting conditions may require ambient temperature of 5° C or higher.

Notes: [1] For double reduction and 1/8 HP single reduction Y4 ratings, refer to selection tables on pages 2.91 thru 2.130.  
[2] Variable Frequency Drive (VFD) notes (see page 2.8 for Constant Torque Speed Ranges):



# Y4 Mounting Single Reduction Selection Tables

**7.5 HP**  
(5.5 kW)

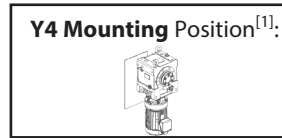

Dimension Pages:  
Single Reduction 2.132-2.143  
Single Reduction, Y2 2.144  
Double Reduction 2.146-2.161  
Double Reduction, Y2 2.162

Frequency	50 Hz	60 Hz
Input Speed	1450 RPM	1750 RPM
Number of Poles	4	

50Hz					60 Hz					Selection							
Output Speed (RPM)	Output Torque		Service Factor		Solid Shaft Overhung Load		Output Speed (RPM)	Output Torque		Service Factor <sup>[1]</sup>		Solid Shaft Overhung Load		Base			VFD <sup>[1]</sup>
	in-lbs	(N·m)	SF	AGMA Class	lbs	(N)		in-lbs	(N·m)	SF	AGMA Class	lbs	(N)	Motor Power Code	Frame Size	Ratio	
41.2	10400 (1180)		0.92	-	3810 (17000)	49.7	8620 (974)	0.92	-	4380 (19500)	8	<b>4A120</b>	35				
			1.08	I	3810 (17000)			1.08	I	4380 (19500)	8	<b>4A125</b>	35				
			1.10	I	3810 (17000)			1.10	I	4380 (19500)	8	<b>4A140</b>	35				
			1.08	I	6820 (30300)			1.08	I	6570 (29200)	8	<b>4B125</b>	35				
			2.02	III	6820 (30300)			2.02	III	6570 (29200)	8	<b>4B140</b>	35				
			2.19	III	6820 (30300)			2.19	III	6570 (29200)	8	<b>4B160</b>	35				
			2.75	III	9930 (44200)			2.75	III	9500 (42200)	8	<b>4C160</b>	35				
			2.75	III	14900 (66300)			2.75	III	14200 (63100)	8	<b>4D160</b>	35				
			2.59	III	19400 (86500)			2.59	III	18500 (82200)	8	<b>4E170</b>	35				
37.7	11400 (1290)		0.92	-	3160 (14000)	45.5	9430 (1070)	0.92	-	4320 (19200)	8	<b>4A120</b>	39				
			1.00	I	3160 (14000)			1.00	I	4320 (19200)	8	<b>4A125</b>	39				
			1.08	I	6930 (30800)			1.08	I	6690 (29800)	8	<b>4B125</b>	39				
			2.00	III	6930 (30800)			2.00	III	6690 (29800)	8	<b>4B140</b>	39				
			2.02	III	10100 (45100)			2.02	III	9700 (43200)	8	<b>4C140</b>	39				
			2.75	III	10100 (45100)			2.75	III	9700 (43200)	8	<b>4C160</b>	39				
			2.75	III	15300 (67900)			2.75	III	14500 (64600)	8	<b>4D160</b>	39				
			2.59	III	19900 (88700)			2.59	III	18900 (84200)	8	<b>4E170</b>	39				
			31.9	13400 (1520)				0.92	-	7120 (31700)	38.5	11100 (1260)	0.92		-	6900 (30700)	8
1.08	I	7120 (31700)				1.08	I	6900 (30700)	8	<b>4B125</b>			46				
1.38	I	7120 (31700)				1.38	I	6900 (30700)	8	<b>4B140</b>			46				
1.69	II	7120 (31700)				1.69	II	6900 (30700)	8	<b>4B160</b>			46				
2.02	III	10500 (46800)				2.02	III	10100 (44900)	8	<b>4C160</b>			46				
2.59	III	10500 (46800)				2.59	III	10100 (44900)	8	<b>4C170</b>			46				
2.59	III	15900 (70900)				2.59	III	15200 (67500)	8	<b>4D170</b>			46				
2.59	III	20800 (92700)				2.59	III	19800 (88100)	8	<b>4E170</b>			46				
27.6	15500 (1750)					0.92	-	7280 (32400)	33.3	12900 (1450)			0.92	-	7070 (31500)	8	<b>4B120</b>
			1.08	I	7280 (32400)	1.08	I	7070 (31500)			8	<b>4B125</b>	53				
			1.38	I	7280 (32400)	1.38	I	7070 (31500)			8	<b>4B140</b>	53				
			1.47	II	7280 (32400)	1.47	II	7070 (31500)			8	<b>4B160</b>	53				
			2.02	III	10800 (48200)	2.02	III	10400 (46300)			8	<b>4C160</b>	53				
			2.18	III	10800 (48200)	2.18	III	10400 (46300)			8	<b>4C170</b>	53				
			2.18	III	16500 (73400)	2.18	III	15700 (70100)			8	<b>4D170</b>	53				
			2.59	III	16500 (73400)	2.59	III	15700 (70100)			8	<b>4D180</b>	53				
			2.59	III	21700 (96300)	2.59	III	20600 (91600)			8	<b>4E180</b>	53				
			2.59	III	31500 (140000)	2.59	III	31600 (141000)			8	<b>4F180</b>	53				

Notes: [1] For double reduction and 1/8 HP single reduction Y4 ratings, refer to selection tables on pages 2.91 thru 2.130.  
[2] Variable Frequency Drive (VFD) notes (see page 2.8 for Constant Torque Speed Ranges):

# Y4 Mounting Single Reduction Selection Tables

**7.5 HP**  
(5.5 kW)

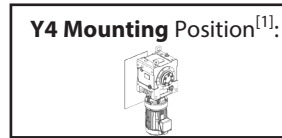

Dimension Pages:  
Single Reduction 2.132-2.143  
Single Reduction, Y2 2.144  
Double Reduction 2.146-2.161  
Double Reduction, Y2 2.162

Frequency	50 Hz	60 Hz
Input Speed	1450 RPM	1750 RPM
Number of Poles	4	

50Hz					60 Hz					Selection							
Output Speed (RPM)	Output Torque		Service Factor		Solid Shaft Overhung Load		Output Speed (RPM)	Output Torque		Service Factor <sup>[1]</sup>		Solid Shaft Overhung Load		Base			VFD <sup>[1]</sup>
	in-lbs	(N·m)	SF	AGMA Class	lbs	(N)		in-lbs	(N·m)	SF	AGMA Class	lbs	(N)	Motor Power Code	Frame Size	Ratio	
24.4	17600 (1990)		0.89	-	7400 (32900)	29.4	14600 (1650)	0.89	-	7210 (32100)	8	<b>4B120</b>	60				
			1.03	I	7400 (32900)			1.03	I	7210 (32100)	8	<b>4B125</b>	60				
			1.29	I	7400 (32900)			1.29	I	7210 (32100)	8	<b>4B160</b>	60				
			2.02	III	11100 (49400)			2.02	III	10700 (47600)	8	<b>4C160</b>	60				
			2.02	III	17000 (75700)			2.02	III	16300 (72300)	8	<b>4D160</b>	60				
			2.59	III	17000 (75700)			2.59	III	16300 (72300)	8	<b>4D180</b>	60				
			2.59	III	22400 (99500)			2.59	III	21300 (94700)	8	<b>4E180</b>	60				
			2.59	III	31400 (140000)			2.59	III	31500 (140000)	8	<b>4F180</b>	60				
			21.6	19900 (2240)				0.87	-	6990 (31100)	26.0	16500 (1860)	0.89		-	7330 (32600)	8
1.01	I	6990 (31100)				1.01	I	7330 (32600)	8	<b>4B140</b>			67				
1.15	I	6990 (31100)				1.15	I	7330 (32600)	8	<b>4B160</b>			67				
1.38	I	11400 (50600)				1.38	I	11000 (48800)	8	<b>4C160</b>			67				
1.77	II	11400 (50600)				1.77	II	11000 (48800)	8	<b>4C170</b>			67				
1.77	II	17500 (77900)				1.77	II	16700 (74500)	8	<b>4D170</b>			67				
2.59	III	17500 (77900)				2.59	III	16700 (74500)	8	<b>4D180</b>			67				
2.59	III	22800 (101000)				2.59	III	22000 (97800)	8	<b>4E180</b>			67				
2.59	III	31300 (139000)				2.59	III	31500 (140000)	8	<b>4F180</b>			67				
19.7	21700 (2450)		0.87	-	6220 (27700)	23.8	18000 (2030)	0.89	-	7420 (33000)	8	<b>4B125</b>	74				
			1.01	I	6220 (27700)			1.01	I	7420 (33000)	8	<b>4B140</b>	74				
			1.05	I	6220 (27700)			1.05	I	7420 (33000)	8	<b>4B160</b>	74				
			1.38	I	11600 (51400)			1.38	I	11200 (49600)	8	<b>4C160</b>	74				
			1.77	II	11600 (51400)			1.77	II	11200 (49600)	8	<b>4C170</b>	74				
			1.77	II	17900 (79600)			1.77	II	17100 (76100)	8	<b>4D170</b>	74				
			2.59	III	17900 (79600)			2.59	III	17100 (76100)	8	<b>4D180</b>	74				
			2.59	III	22700 (101000)			2.59	III	22500 (100000)	8	<b>4E180</b>	74				
			2.59	III	31200 (139000)			2.59	III	31400 (140000)	8	<b>4F180</b>	74				
18.1	23600 (2670)		0.96	-	5220 (23200)	21.9	19600 (2210)	0.96	-	7090 (31600)	8	<b>4B140</b>	80				
			1.01	I	11700 (52100)			1.01	I	11300 (50400)	8	<b>4C140</b>	80				
			1.38	I	11700 (52100)			1.38	I	11300 (50400)	8	<b>4C160</b>	80				
			1.92	II	11700 (52100)			1.92	II	11300 (50400)	8	<b>4C170</b>	80				
			2.02	III	18200 (81200)			2.02	III	17500 (77700)	8	<b>4D170</b>	80				
			2.18	III	18200 (81200)			2.18	III	17500 (77700)	8	<b>4D180</b>	80				
			2.18	III	22600 (101000)			2.18	III	22800 (101000)	8	<b>4E180</b>	80				
			2.59	III	22600 (101000)			2.59	III	22800 (101000)	8	<b>4E190</b>	80				
			2.59	III	31100 (139000)			2.59	III	31300 (139000)	8	<b>4F190</b>	80				

Notes: [1] For double reduction and 1/8 HP single reduction Y4 ratings, refer to selection tables on pages 2.91 thru 2.130.  
[2] Variable Frequency Drive (VFD) notes (see page 2.8 for Constant Torque Speed Ranges):

# Y4 Mounting Single Reduction Selection Tables

**7.5 HP  
(5.5 kW)**

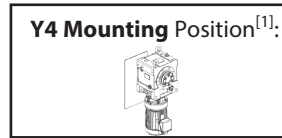

Dimension Pages:  
 Single Reduction 2.132-2.143  
 Single Reduction,Y2 2.144  
 Double Reduction 2.146-2.161  
 Double Reduction, Y2 2.162

Frequency	50 Hz	60 Hz
Input Speed	1450 RPM	1750 RPM
Number of Poles	4	

50Hz					60 Hz					Selection							
Output Speed (RPM)	Output Torque		Service Factor		Solid Shaft Overhung Load		Output Speed (RPM)	Output Torque		Service Factor <sup>[1]</sup>		Solid Shaft Overhung Load		Base			VFD <sup>[1]</sup>
	in-lbs	(N·m)	SF	AGMA Class	lbs	(N)		in-lbs	(N·m)	SF	AGMA Class	lbs	(N)	Motor Power Code	Frame Size	Ratio	
16.6	25900 (2920)		0.88	-	3570 (15900)	20.0	21400 (2420)	0.88	-	6350 (28300)	8	<b>4B140</b>	88				
			1.01	I	11900 (52900)			1.01	I	11500 (51300)	8	<b>4C140</b>	88				
			1.38	I	11900 (52900)			1.38	I	11500 (51300)	8	<b>4C160</b>	88				
			1.76	II	11900 (52900)			1.76	II	11500 (51300)	8	<b>4C170</b>	88				
			2.02	III	18600 (82800)			2.02	III	17800 (79300)	8	<b>4D170</b>	88				
			2.18	III	18600 (82800)			2.18	III	17800 (79300)	8	<b>4D180</b>	88				
			2.18	III	22500 (100000)			2.18	III	22700 (101000)	8	<b>4E180</b>	88				
			2.59	III	22500 (100000)			2.59	III	22700 (101000)	8	<b>4E190</b>	88				
			2.59	III	31000 (138000)			2.59	III	31200 (139000)	8	<b>4F190</b>	88				
14.3	30000 (3390)		1.38	I	12200 (54000)	17.2	24900 (2810)	1.38	I	11800 (52600)	8	<b>4C160</b>	102				
			1.52	II	12200 (54000)			1.52	II	11800 (52600)	8	<b>4C170</b>	102				
			2.02	III	19200 (85500)			2.02	III	18500 (82100)	8	<b>4D170</b>	102				
			2.02	III	22300 (99100)			2.02	III	22500 (100000)	8	<b>4E170</b>	102				
			2.59	III	22300 (99100)			2.59	III	22500 (100000)	8	<b>4E190</b>	102				
			2.59	III	30900 (137000)			2.59	III	31100 (138000)	8	<b>4F190</b>	102				
12.9	33100 (3740)		1.37	I	12300 (54700)	15.6	27400 (3100)	1.37	I	12000 (53300)	8	<b>4C160</b>	112				
			1.38	I	19600 (87300)			1.38	I	18900 (83900)	8	<b>4D160</b>	112				
			1.77	II	19600 (87300)			1.77	II	18900 (83900)	8	<b>4D180</b>	112		(-)		
			1.77	II	22100 (98400)			1.77	II	22400 (99700)	8	<b>4E180</b>	112		(-)		
			2.18	III	22100 (98400)			2.18	III	22400 (99700)	8	<b>4E190</b>	112				
			2.18	III	30700 (137000)			2.18	III	31000 (138000)	8	<b>4F190</b>	112				
11.8	36200 (4090)		1.26	I	12300 (54800)	14.3	30000 (3390)	1.26	I	12200 (54000)	8	<b>4C160</b>	123				
			1.38	I	20000 (88900)			1.38	I	19200 (85500)	8	<b>4D160</b>	123				
			1.77	II	20000 (88900)			1.77	II	19200 (85500)	8	<b>4D180</b>	123		(-)		
			1.77	II	22000 (97700)			1.77	II	22300 (99100)	8	<b>4E180</b>	123		(-)		
			2.18	III	22000 (97700)			2.18	III	22300 (99100)	8	<b>4E190</b>	123				
			2.18	III	30600 (136000)			2.18	III	30900 (137000)	8	<b>4F190</b>	123				
9.63	44500 (5030)		1.02	I	9820 (43700)	11.6	36900 (4160)	1.02	I	12200 (54100)	8	<b>4C170</b>	151				
			1.38	I	19200 (85500)			1.38	I	20100 (89200)	8	<b>4D170</b>	151				
			1.38	I	21600 (95900)			1.38	I	21900 (97600)	8	<b>4E170</b>	151				
			1.77	II	21600 (95900)			1.77	II	21900 (97600)	8	<b>4E190</b>	151				
			1.77	II	30200 (135000)			1.77	II	30600 (136000)	8	<b>4F190</b>	151				
8.12	52800 (5960)		0.86	-	5440 (24200)	9.80	43700 (4940)	0.86	-	10100 (44900)	8	<b>4C170</b>	179				
			1.01	I	17900 (79700)			1.01	I	19300 (86000)	8	<b>4D170</b>	179				
			1.01	I	21100 (94000)			1.01	I	21600 (96000)	8	<b>4E170</b>	179				
			1.29	I	21100 (94000)			1.29	I	21600 (96000)	8	<b>4E190</b>	179				
			1.29	I	29900 (133000)			1.29	I	30300 (135000)	8	<b>4F190</b>	179				

Notes: [1] For double reduction and 1/8 HP single reduction Y4 ratings, refer to selection tables on pages 2.91 thru 2.130.  
 [2] Variable Frequency Drive (VFD) notes (see page 2.8 for Constant Torque Speed Ranges):

# Y4 Mounting Single Reduction Selection Tables

**7.5 HP  
(5.5 kW)**

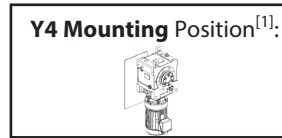

Dimension Pages:  
 Single Reduction 2.132-2.143  
 Single Reduction,Y2 2.144  
 Double Reduction 2.146-2.161  
 Double Reduction, Y2 2.162

Frequency	50 Hz	60 Hz
Input Speed	1450 RPM	1750 RPM
Number of Poles	4	

50Hz					60 Hz					Selection							
Output Speed (RPM)	Output Torque		Service Factor		Solid Shaft Overhung Load		Output Speed (RPM)	Output Torque		Service Factor <sup>[1]</sup>		Solid Shaft Overhung Load		Base			VFD <sup>[1]</sup>
	in-lbs	(N·m)	SF	AGMA Class	lbs	(N)		in-lbs	(N·m)	SF	AGMA Class	lbs	(N)	Motor Power Code	Frame Size	Ratio	
7.02	61000 (6900)		1.01	I	16300 (72300)	8.47	50600 (5710)	1.01	I	18300 (81400)	8	<b>4D170</b>	207				
			1.26	I	16300 (72300)			1.38	I	18300 (81400)	8	<b>4D180</b>	207				
			1.38	I	20700 (92100)			1.38	I	21200 (94500)	8	<b>4E180</b>	207				
			1.38	I	29500 (131000)			1.38	I	30000 (133000)	8	<b>4F180</b>	207				
5.84	73500 (8300)		1.01	I	12800 (56900)	7.04	60900 (6880)	1.01	I	16300 (72500)	8	<b>4D180</b>	249				
			1.01	I	20100 (89300)			1.01	I	20700 (92200)	8	<b>4E180</b>	249				
			1.01	I	29000 (129000)			1.01	I	29500 (131000)	8	<b>4F180</b>	249				
4.76	90000 (10200)		0.86	-	272 (1210)	5.75	74600 (8430)	1.01	I	12400 (55100)	8	<b>4D180</b>	305				
			1.01	I	19200 (85600)			1.01	I	20000 (89100)	8	<b>4E180</b>	305				
			1.01	I	28300 (126000)			1.01	I	28900 (129000)	8	<b>4F180</b>	305				

Notes: [1] For double reduction and 1/8 HP single reduction Y4 ratings, refer to selection tables on pages 2.91 thru 2.130.  
 [2] Variable Frequency Drive (VFD) notes (see page 2.8 for Constant Torque Speed Ranges):

# Y4 Mounting Single Reduction Selection Tables

**10 HP  
(7.5 kW)**

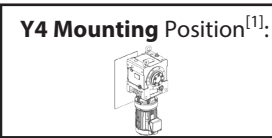

Dimension Pages:

Single Reduction	2.132-2.143
Single Reduction, Y2	2.144
Double Reduction	2.146-2.161
Double Reduction, Y2	2.162

Frequency	50 Hz	60 Hz
Input Speed	1450 RPM	1750 RPM
Number of Poles	4	

50Hz					60 Hz					Selection							
Output Speed (RPM)	Output Torque		Service Factor		Solid Shaft Overhung Load		Output Speed (RPM)	Output Torque		Service Factor <sup>[1]</sup>		Solid Shaft Overhung Load		Base			VFD <sup>[1]</sup>
	in-lbs	(N·m)	SF	AGMA Class	lbs	(N)		in-lbs	(N·m)	SF	AGMA Class	lbs	(N)	Motor Power Code	Frame Size	Ratio	
69.0	8470 (956)		1.35	I	3880 (17300)	83.3	7010 (792)		1.35	I	3800 (16900)	10	<b>4A140</b>	21			
			1.48	II	5890 (26200)				1.48	II	5670 (25200)	10	<b>4B140</b>	21			
			1.48	II	8540 (38000)				1.48	II	8170 (36300)	10	<b>4C140</b>	21			
64.7	9030 (1020)		1.26	I	3900 (17400)	78.1	7480 (845)		1.26	I	3830 (17000)	10	<b>4A140</b>	22			
			1.48	II	5960 (26500)				1.48	II	5740 (25600)	10	<b>4B140</b>	22			
			2.02	III	5960 (26500)				2.02	III	5740 (25600)	10	<b>4B160</b>	22			
			2.02	III	8670 (38600)				2.02	III	8300 (36900)	10	<b>4C160</b>	22			
			2.02	III	13000 (57900)				2.02	III	12400 (55100)	10	<b>4D160</b>	22			
59.2	9880 (1120)		1.16	I	3930 (17500)	71.4	8180 (925)		1.16	I	3870 (17200)	10	<b>4A140</b>	25			
			1.48	II	6060 (26900)				1.48	II	5850 (26000)	10	<b>4B140</b>	25			
			2.02	III	6060 (26900)				2.02	III	5850 (26000)	10	<b>4B160</b>	25			
			2.02	III	8850 (39400)				2.02	III	8480 (37700)	10	<b>4C160</b>	25			
			2.02	III	13300 (59300)				2.02	III	12700 (56500)	10	<b>4D160</b>	25			
51.8	11300 (1280)		1.01	I	3230 (14400)	62.5	9350 (1060)		1.01	I	3910 (17400)	10	<b>4A140</b>	28			
			1.48	II	6200 (27600)				1.48	II	6000 (26700)	10	<b>4B140</b>	28			
			2.02	III	6200 (27600)				2.02	III	6000 (26700)	10	<b>4B160</b>	28			
			2.02	III	9120 (40600)				2.02	III	8740 (38900)	10	<b>4C160</b>	28			
			2.02	III	13800 (61400)				2.02	III	13100 (58500)	10	<b>4D160</b>	28			
			3.19	III	13800 (61400)				3.19	III	13100 (58500)	10	<b>4D160</b>	28			
41.2	14200 (1600)		1.48	II	6410 (28500)	49.7	11800 (1330)		1.48	II	6230 (27700)	10	<b>4B140</b>	35			
			1.60	II	6410 (28500)				1.60	II	6230 (27700)	10	<b>4B160</b>	35			
			2.02	III	9570 (42600)				2.02	III	9200 (40900)	10	<b>4C160</b>	35			
			2.02	III	14600 (65000)				2.02	III	13900 (62000)	10	<b>4D160</b>	35			
			2.59	III	14600 (65000)				2.59	III	13900 (62000)	10	<b>4D180</b>	35			
			2.59	III	19200 (85300)				2.59	III	18200 (81100)	10	<b>4E180</b>	35			
			3.19	III	19200 (85300)				3.19	III	18200 (81100)	10	<b>4E190</b>	35			
			3.19	III	31600 (140000)				3.19	III	30800 (137000)	10	<b>4F190</b>	35			
			3.19	III	31600 (140000)				3.19	III	30800 (137000)	10	<b>4F190</b>	35			
37.7	15500 (1750)		1.47	II	6480 (28800)	45.5	12900 (1450)		1.47	II	6320 (28100)	10	<b>4B140</b>	39			
			1.48	II	9740 (43300)				1.48	II	9380 (41700)	10	<b>4C140</b>	39			
			2.02	III	9740 (43300)				2.02	III	9380 (41700)	10	<b>4C160</b>	39			
			2.02	III	14900 (66400)				2.02	III	14300 (63400)	10	<b>4D160</b>	39			
			2.59	III	14900 (66400)				2.59	III	14300 (63400)	10	<b>4D180</b>	39			
			2.59	III	19600 (87300)				2.59	III	18700 (83100)	10	<b>4E180</b>	39			
			3.19	III	19600 (87300)				3.19	III	18700 (83100)	10	<b>4E190</b>	39			
			3.19	III	31500 (140000)				3.19	III	31600 (141000)	10	<b>4F190</b>	39			
			3.19	III	31500 (140000)				3.19	III	31600 (141000)	10	<b>4F190</b>	39			

Notes: [1] For double reduction and 1/8 HP single reduction Y4 ratings, refer to selection tables on pages 2.91 thru 2.130.  
[2] Variable Frequency Drive (VFD) notes (see page 2.8 for Constant Torque Speed Ranges):

# Y4 Mounting Single Reduction Selection Tables

**10 HP  
(7.5 kW)**

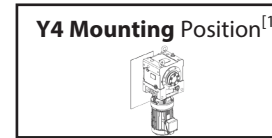

Dimension Pages:

Single Reduction	2.132-2.143
Single Reduction, Y2	2.144
Double Reduction	2.146-2.161
Double Reduction, Y2	2.162

Frequency	50 Hz	60 Hz
Input Speed	1450 RPM	1750 RPM
Number of Poles	4	

50Hz					60 Hz					Selection							
Output Speed (RPM)	Output Torque		Service Factor		Solid Shaft Overhung Load		Output Speed (RPM)	Output Torque		Service Factor <sup>[1]</sup>		Solid Shaft Overhung Load		Base			VFD <sup>[1]</sup>
	in-lbs	(N·m)	SF	AGMA Class	lbs	(N)		in-lbs	(N·m)	SF	AGMA Class	lbs	(N)	Motor Power Code	Frame Size	Ratio	
31.9	18300 (2070)		1.01	I	6600 (29300)	38.5	15200 (1720)		1.01	I	6470 (28800)	10	<b>4B140</b>	46			
			1.24	I	6600 (29300)				1.24	I	6470 (28800)	10	<b>4B160</b>	46			
			1.48	II	10000 (44700)				1.48	II	9700 (43100)	10	<b>4C160</b>	46			
			1.90	II	10000 (44700)				1.90	II	9700 (43100)	10	<b>4C170</b>	46			
			1.90	II	15500 (69100)				1.90	II	14900 (66100)	10	<b>4D170</b>	46			
			2.59	III	15500 (69100)				2.59	III	14900 (66100)	10	<b>4D180</b>	46			
27.6	21200 (2390)		1.01	I	6470 (28800)	33.3	17500 (1980)		1.01	I	6570 (29200)	10	<b>4B140</b>	53			
			1.07	I	6470 (28800)				1.07	I	6570 (29200)	10	<b>4B160</b>	53			
			1.48	II	10300 (45800)				1.48	II	9970 (44300)	10	<b>4C160</b>	53			
			1.60	II	10300 (45800)				1.60	II	9970 (44300)	10	<b>4C170</b>	53			
			1.60	II	16100 (71400)				1.60	II	15400 (68400)	10	<b>4D170</b>	53			
			1.90	II	16100 (71400)				1.90	II	15400 (68400)	10	<b>4D180</b>	53			
24.4	24000 (2710)		0.95	-	5010 (22300)	29.4	19900 (2250)		0.95	-	6640 (29500)	10	<b>4B160</b>	60			
			1.48	II	10500 (46700)				1.48	II	10200 (45300)	10	<b>4C160</b>	60			
			1.48	II	16500 (73400)				1.48	II	15800 (70400)	10	<b>4D160</b>	60			
			1.90	II	16500 (73400)				1.90	II	15800 (70400)	10	<b>4D180</b>	60			
			1.90	II	21900 (97400)				1.90	II	20900 (93000)	10	<b>4E180</b>	60			
			3.19	III	21900 (97400)				3.19	III	20900 (93000)	10	<b>4E190</b>	60			
21.6	27100 (3060)		0.84	-	2050 (9110)	26.0	22400 (2540)		0.84	-	5880 (26100)	10	<b>4B160</b>	67			
			1.01	I	10700 (47500)				1.01	I	10400 (46200)	10	<b>4C160</b>	67			
			1.29	I	10700 (47500)				1.29	I	10400 (46200)	10	<b>4C170</b>	67			
			1.29	I	16900 (75400)				1.29	I	16300 (72400)	10	<b>4D170</b>	67			
			1.90	II	16900 (75400)				1.90	II	16300 (72400)	10	<b>4D180</b>	67			
			1.90	II	22400 (99800)				1.90	II	21500 (95800)	10	<b>4E180</b>	67			
19.7	29600 (3350)		1.01	I	10800 (48100)	23.8	24500 (2770)		1.01	I	10500 (46900)	10	<b>4C160</b>	74			
			1.29	I	10800 (48100)				1.29	I	10500 (46900)	10	<b>4C170</b>	74			
			1.29	I	17300 (76800)				1.29	I	16600 (73800)	10	<b>4D170</b>	74			
			1.90	II	17300 (76800)				1.90	II	16600 (73800)	10	<b>4D180</b>	74			
			1.90	II	22300 (99200)				1.90	II	22000 (98000)	10	<b>4E180</b>	74			
			1.90	II	30900 (137000)				1.90	II	31100 (138000)	10	<b>4F180</b>	74			

Notes: [1] For double reduction and 1/8 HP single reduction Y4 ratings, refer to selection tables on pages 2.91 thru 2.130.  
[2] Variable Frequency Drive (VFD) notes (see page 2.8 for Constant Torque Speed Ranges):

(-) = For inverter operation, starting conditions may require ambient temperature of 5° C or higher.

# Y4 Mounting Single Reduction Selection Tables

**10 HP  
(7.5 kW)**

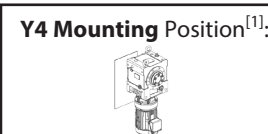

Dimension Pages:  
Single Reduction 2.132-2.143  
Single Reduction, Y2 2.144  
Double Reduction 2.146-2.161  
Double Reduction, Y2 2.162

Frequency	50 Hz	60 Hz
Input Speed	1450 RPM	1750 RPM
Number of Poles	4	

50Hz				60 Hz				Selection									
Output Speed (RPM)	Output Torque		Service Factor		Solid Shaft Overhung Load		Output Speed (RPM)	Output Torque		Service Factor <sup>[1]</sup>		Solid Shaft Overhung Load		Base			VFD <sup>[1]</sup>
	in-lbs	(N·m)	SF	AGMA Class	lbs	(N)		in-lbs	(N·m)	SF	AGMA Class	lbs	(N)	Motor Power Code	Frame Size	Ratio	
18.1	32200 (3640)		1.01	I	10900 (48500)	21.9	26700 (3020)	1.01	I	10700 (47400)	10	<b>4C160</b>	80				
			1.41	II	10900 (48500)			1.41	II	10700 (47400)	10	<b>4C170</b>	80				
			1.48	II	17600 (78100)			1.48	II	16900 (75100)	10	<b>4D170</b>	80				
			1.60	II	17600 (78100)			1.60	II	16900 (75100)	10	<b>4D180</b>	80		(-)		
			1.60	II	22200 (98600)			1.60	II	22500 (99900)	10	<b>4E180</b>	80		(-)		
			1.90	II	22200 (98600)			1.90	II	22500 (99900)	10	<b>4E190</b>	80				
			1.90	II	30800 (137000)			1.90	II	31000 (138000)	10	<b>4F190</b>	80				
16.6	35300 (3990)		1.01	I	11000 (48900)	20.0	29200 (3300)	1.01	I	10800 (48000)	10	<b>4C160</b>	88				
			1.29	I	11000 (48900)			1.29	I	10800 (48000)	10	<b>4C170</b>	88				
			1.48	II	17900 (79400)			1.48	II	17200 (76600)	10	<b>4D170</b>	88				
			1.60	II	17900 (79400)			1.60	II	17200 (76600)	10	<b>4D180</b>	88		(-)		
			1.60	II	22000 (97900)			1.60	II	22300 (99300)	10	<b>4E180</b>	88		(-)		
			1.90	II	22000 (97900)			1.90	II	22300 (99300)	10	<b>4E190</b>	88				
			1.90	II	30600 (136000)			1.90	II	30900 (137000)	10	<b>4F190</b>	88				
14.3	40900 (4620)		1.01	I	11000 (49100)	17.2	33900 (3830)	1.01	I	11000 (48700)	10	<b>4C160</b>	102				
			1.11	I	11000 (49100)			1.11	I	11000 (48700)	10	<b>4C170</b>	102				
			1.48	II	18300 (81600)			1.48	II	17700 (78800)	10	<b>4D170</b>	102				
			1.48	II	21700 (96700)			1.48	II	22100 (98300)	10	<b>4E170</b>	102				
			1.90	II	21700 (96700)			1.90	II	22100 (98300)	10	<b>4E190</b>	102				
			1.90	II	30400 (135000)			1.90	II	30700 (137000)	10	<b>4F190</b>	102				
			12.9	45100 (5100)				1.01	I	9560 (42500)	15.6	37400 (4230)	1.01		I	11000 (49100)	10
1.01	I	18700 (83000)				1.01	I	18100 (80300)	10	<b>4D160</b>			112				
1.29	I	18700 (83000)				1.29	I	18100 (80300)	10	<b>4D180</b>			112	(-)			
1.29	I	21500 (95700)				1.29	I	21900 (97500)	10	<b>4E180</b>			112	(-)			
1.60	II	21500 (95700)				1.60	II	21900 (97500)	10	<b>4E190</b>			112				
1.60	II	30200 (134000)				1.60	II	30600 (136000)	10	<b>4F190</b>			112				
11.8	49400 (5580)					0.92	-	7640 (34000)	14.3	40900 (4620)			0.92	-	11000 (49100)	10	<b>4C160</b>
			1.01	I	18500 (82200)	1.01	I	18300 (81600)			10	<b>4D160</b>	123				
			1.29	I	18500 (82200)	1.29	I	18300 (81600)			10	<b>4D180</b>	123	(-)			
			1.29	I	21300 (94800)	1.29	I	21700 (96700)			10	<b>4E180</b>	123	(-)			
			1.60	II	21300 (94800)	1.60	II	21700 (96700)			10	<b>4E190</b>	123				
			1.60	II	30000 (134000)	1.60	II	30400 (135000)			10	<b>4F190</b>	123				
			9.63	60700 (6850)		1.01	I	16300 (72700)			11.6	50300 (5680)	1.01	I	18300 (81600)	10	<b>4D170</b>
1.01	I	20700 (92200)				1.01	I	21300 (94600)	10	<b>4E170</b>			151				
1.29	I	20700 (92200)				1.29	I	21300 (94600)	10	<b>4E190</b>			151	(-)			
1.29	I	29500 (131000)				1.29	I	30000 (133000)	10	<b>4F190</b>			151	(-)			
8.12	72000 (8130)		0.95	-	20200 (89700)	9.80	59600 (6740)	0.95	-	20800 (92500)	10	<b>4E190</b>	179	(-)			
			0.95	-	29100 (129000)			0.95	-	29600 (132000)	10	<b>4F190</b>	179	(-)			

Notes: [1] For double reduction and 1/8 HP single reduction Y4 ratings, refer to selection tables on pages 2.91 thru 2.130.  
[2] Variable Frequency Drive (VFD) notes (see page 2.8 for Constant Torque Speed Ranges):

(-) = For inverter operation, starting conditions may require ambient temperature of 5° C or higher.

# Y4 Mounting Single Reduction Selection Tables

**10 HP  
(7.5 kW)**

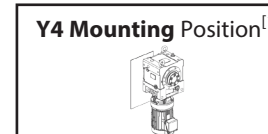

Dimension Pages:  
Single Reduction 2.132-2.143  
Single Reduction, Y2 2.144  
Double Reduction 2.146-2.161  
Double Reduction, Y2 2.162

Frequency	50 Hz	60 Hz
Input Speed	1450 RPM	1750 RPM
Number of Poles	4	

50Hz				60 Hz				Selection									
Output Speed (RPM)	Output Torque		Service Factor		Solid Shaft Overhung Load		Output Speed (RPM)	Output Torque		Service Factor <sup>[1]</sup>		Solid Shaft Overhung Load		Base			VFD <sup>[1]</sup>
	in-lbs	(N·m)	SF	AGMA Class	lbs	(N)		in-lbs	(N·m)	SF	AGMA Class	lbs	(N)	Motor Power Code	Frame Size	Ratio	
7.02	83200 (9400)		0.93	-	8420 (37500)		8.47	69000 (7790)	1.01	I	14200 (63200)	10	<b>4D180</b>	207			
			1.01	I	19600 (87100)				1.01	I	20300 (90300)	10	<b>4E180</b>	207			
			1.01	I	28600 (127000)				1.01	I	29200 (130000)	10	<b>4F180</b>	207			

Notes: [1] For double reduction and 1/8 HP single reduction Y4 ratings, refer to selection tables on pages 2.91 thru 2.130.  
[2] Variable Frequency Drive (VFD) notes (see page 2.8 for Constant Torque Speed Ranges):



# Y4 Mounting Single Reduction Selection Tables

**15 HP**  
(11 kW)



Dimension Pages:  
Single Reduction 2.132-2.143  
Single Reduction, Y2 2.144  
Double Reduction 2.146-2.161  
Double Reduction, Y2 2.162

Frequency	50 Hz	60 Hz
Input Speed	1450 RPM	1750 RPM
Number of Poles	4	

50Hz					60 Hz					Selection							
Output Speed (RPM)	Output Torque		Service Factor		Solid Shaft Overhung Load		Output Speed (RPM)	Output Torque		Service Factor <sup>(1)</sup>		Solid Shaft Overhung Load		Base			VFD <sup>(1)</sup>
	in-lbs	(N·m)	SF	AGMA Class	lbs	(N)		in-lbs	(N·m)	SF	AGMA Class	lbs	(N)	Motor Power Code	Frame Size	Ratio	
69.0	12400 (1400)		0.92	-	2160 (9600)	83.3	10300 (1160)		0.92	-	3350 (14900)	15	<b>4A140</b>	21			
			1.01	I	5460 (24300)				1.01	I	5320 (23700)	15	<b>4B140</b>	21			
			1.01	I	8170 (36300)				1.01	I	7860 (35000)	15	<b>4C140</b>	21			
64.7	13200 (1500)		0.86	-	290 (1290)	78.1	11000 (1240)		0.86	-	3350 (14900)	15	<b>4A140</b>	22			
			1.01	I	5500 (24500)				1.01	I	5370 (23900)	15	<b>4B140</b>	22			
			1.38	I	5500 (24500)				1.38	I	5370 (23900)	15	<b>4B160</b>	22			
			1.38	I	8270 (36800)				1.38	I	7970 (35400)	15	<b>4C160</b>	22			
			1.38	I	12700 (56400)				1.38	I	12100 (53900)	15	<b>4D160</b>	22			
59.2	14500 (1640)		1.01	I	5560 (24700)	71.4	12000 (1360)		1.01	I	5440 (24200)	15	<b>4B140</b>	25			
			1.38	I	5560 (24700)				1.38	I	5440 (24200)	15	<b>4B160</b>	25			
			1.38	I	8420 (37400)				1.38	I	8110 (36100)	15	<b>4C160</b>	25			
			1.38	I	13000 (57700)				1.38	I	12400 (55100)	15	<b>4D160</b>	25			
51.8	16600 (1870)		1.01	I	5630 (25000)	62.5	13700 (1550)		1.01	I	5530 (24600)	15	<b>4B140</b>	28			
			1.37	I	5630 (25000)				1.37	I	5530 (24600)	15	<b>4B160</b>	28			
			1.38	I	8620 (38300)				1.38	I	8330 (37100)	15	<b>4C160</b>	28			
			1.38	I	13400 (59500)				1.38	I	12800 (56900)	15	<b>4D160</b>	28			
			1.38	I					1.38	I		15	<b>4D160</b>	28			
41.2	20800 (2350)		1.01	I	5690 (25300)	49.7	17200 (1950)		1.01	I	5640 (25100)	15	<b>4B140</b>	35			
			1.09	I	5690 (25300)				1.09	I	5640 (25100)	15	<b>4B160</b>	35			
			1.38	I	8940 (39800)				1.38	I	8680 (38600)	15	<b>4C160</b>	35			
			1.38	I	14100 (62600)				1.38	I	13500 (60000)	15	<b>4D160</b>	35			
			1.77	II	14100 (62600)				1.77	II	13500 (60000)	15	<b>4D180</b>	35			
			1.77	II	18700 (83100)				1.77	II	17800 (79400)	15	<b>4E180</b>	35			
			2.18	III	18700 (83100)				2.18	III	17800 (79400)	15	<b>4E190</b>	35			
			2.18	III	31300 (139000)				2.18	III	30500 (135000)	15	<b>4F190</b>	35			
37.7	22800 (2570)		1.00	I	5700 (25400)	45.5	18900 (2130)		1.00	I	5670 (25200)	15	<b>4B140</b>	39			
			1.01	I	9050 (40300)				1.01	I	8810 (39200)	15	<b>4C140</b>	39			
			1.38	I	9050 (40300)				1.38	I	8810 (39200)	15	<b>4C160</b>	39			
			1.38	I	14300 (63800)				1.38	I	13800 (61300)	15	<b>4D160</b>	39			
			1.77	II	14300 (63800)				1.77	II	13800 (61300)	15	<b>4D180</b>	39			
			1.77	II	19100 (84900)				1.77	II	18200 (81100)	15	<b>4E180</b>	39			
			2.18	III	19100 (84900)				2.18	III	18200 (81100)	15	<b>4E190</b>	39			
			2.18	III	31200 (139000)				2.18	III	31200 (139000)	15	<b>4F190</b>	39			
			2.18	III					2.18	III		15	<b>4F190</b>	39			
			2.18	III					2.18	III		15	<b>4F190</b>	39			

Notes: [1] For double reduction and 1/8 HP single reduction Y4 ratings, refer to selection tables on pages 2.91 thru 2.130.  
[2] Variable Frequency Drive (VFD) notes (see page 2.8 for Constant Torque Speed Ranges):

# Y4 Mounting Single Reduction Selection Tables

**15 HP**  
(11 kW)



Dimension Pages:  
Single Reduction 2.132-2.143  
Single Reduction, Y2 2.144  
Double Reduction 2.146-2.161  
Double Reduction, Y2 2.162

Frequency	50 Hz	60 Hz
Input Speed	1450 RPM	1750 RPM
Number of Poles	4	

50Hz					60 Hz					Selection							
Output Speed (RPM)	Output Torque		Service Factor		Solid Shaft Overhung Load		Output Speed (RPM)	Output Torque		Service Factor <sup>(1)</sup>		Solid Shaft Overhung Load		Base			VFD <sup>(1)</sup>
	in-lbs	(N·m)	SF	AGMA Class	lbs	(N)		in-lbs	(N·m)	SF	AGMA Class	lbs	(N)	Motor Power Code	Frame Size	Ratio	
31.9	26900 (3040)		0.85	-	2350 (10500)	38.5	22300 (2520)		0.85	-	5700 (25400)	15	<b>4B160</b>	46			
			1.01	I	9240 (41100)				1.01	I	9030 (40200)	15	<b>4C160</b>	46			
			1.29	I	9240 (41100)				1.29	I	9030 (40200)	15	<b>4C170</b>	46		(-)	
			1.29	I	14800 (66000)				1.29	I	14300 (63500)	15	<b>4D170</b>	46		(-)	
			1.77	II	14800 (66000)				1.77	II	14300 (63500)	15	<b>4D180</b>	46			
27.6	31000 (3510)		1.01	I	9360 (41600)	33.3	25700 (2910)		1.01	I	9190 (40900)	15	<b>4C160</b>	53			
			1.09	I	9360 (41600)				1.09	I	9190 (40900)	15	<b>4C170</b>	53			
			1.09	I	15300 (67900)				1.09	I	14700 (65500)	15	<b>4D170</b>	53			
			1.29	I	15300 (67900)				1.29	I	14700 (65500)	15	<b>4D180</b>	53			
			1.29	I	20500 (91200)				1.29	I	19700 (87400)	15	<b>4E180</b>	53			
			2.18	III	20500 (91200)				2.18	III	19700 (87400)	15	<b>4E190</b>	53			
			2.18	III	30800 (137000)				2.18	III	31100 (138000)	15	<b>4F190</b>	53			
24.4	35200 (3970)		1.01	I	9440 (42000)	29.4	29100 (3290)		1.01	I	9310 (41400)	15	<b>4C160</b>	60			
			1.01	I	15600 (69400)				1.01	I	15100 (67100)	15	<b>4D160</b>	60			
			1.29	I	15600 (69400)				1.29	I	15100 (67100)	15	<b>4D180</b>	60		(-)	
			1.29	I	21100 (93800)				1.29	I	20200 (90000)	15	<b>4E180</b>	60		(-)	
			2.18	III	21100 (93800)				2.18	III	20200 (90000)	15	<b>4E190</b>	60			
			2.18	III	30600 (136000)				2.18	III	30900 (137000)	15	<b>4F190</b>	60			
21.6	39700 (4490)		0.88	-	9480 (42200)	26.0	32900 (3720)		0.88	-	9400 (41800)	15	<b>4C170</b>	67			
			0.88	-	15900 (70800)				0.88	-	15400 (68600)	15	<b>4D170</b>	67			
			1.29	I	15900 (70800)				1.29	I	15400 (68600)	15	<b>4D180</b>	67		(-)	
			1.29	I	21600 (96200)				1.29	I	20800 (92400)	15	<b>4E180</b>	67		(-)	
			1.29	I	30500 (135000)				1.29	I	30700 (137000)	15	<b>4F180</b>	67		(-)	
19.7	43500 (4910)		0.88	-	9490 (42200)	23.8	36000 (4070)		0.88	-	9450 (42000)	15	<b>4C170</b>	74			
			0.88	-	16100 (71800)				0.88	-	15700 (69700)	15	<b>4D170</b>	74			
			1.29	I	16100 (71800)				1.29	I	15700 (69700)	15	<b>4D180</b>	74		(-)	
			1.29	I	21600 (96100)				1.29	I	21200 (94200)	15	<b>4E180</b>	74		(-)	
			1.29	I	30300 (135000)				1.29	I	30600 (136000)	15	<b>4F180</b>	74		(-)	
18.1	47300 (5340)		0.96	-	8660 (38500)	21.9	39200 (4430)		0.96	-	9480 (42200)	15	<b>4C170</b>	80			
			1.01	I	16300 (72700)				1.01	I	15900 (70700)	15	<b>4D170</b>	80			
			1.09	I	16300 (72700)				1.09	I	15900 (70700)	15	<b>4D180</b>	80			
			1.09	I	21400 (95200)				1.09	I	21600 (95900)	15	<b>4E180</b>	80			
			1.29	I	21400 (95200)				1.29	I	21600 (95900)	15	<b>4E190</b>	80			
			1.29	I	30100 (134000)				1.29	I	30500 (136000)	15	<b>4F190</b>	80			

Notes: [1] For double reduction and 1/8 HP single reduction Y4 ratings, refer to selection tables on pages 2.91 thru 2.130.  
[2] Variable Frequency Drive (VFD) notes (see page 2.8 for Constant Torque Speed Ranges):

# Y4 Mounting Single Reduction Selection Tables

**15 HP**  
(11 kW)



Dimension Pages:

Single Reduction	2.132-2.143
Single Reduction, Y2	2.144
Double Reduction	2.146-2.161
Double Reduction, Y2	2.162

Frequency	50 Hz	60 Hz
Input Speed	1450 RPM	1750 RPM
Number of Poles	4	

50Hz					60 Hz					Selection							
Output Speed (RPM)	Output Torque		Service Factor		Solid Shaft Overhung Load		Output Speed (RPM)	Output Torque		Service Factor <sup>[1]</sup>		Solid Shaft Overhung Load		Base			VFD <sup>[1]</sup>
	in-lbs	(N·m)	SF	AGMA Class	lbs	(N)		in-lbs	(N·m)	SF	AGMA Class	lbs	(N)	Motor Power Code	Frame Size	Ratio	
16.6	51700 (5840)		0.88	-	6210 (27600)	20.0	42900 (4840)		0.88	-	9490 (42200)	15	<b>4C170</b>	88			
			1.01	I	16500 (73600)				1.01	I	16100 (71700)	15	<b>4D170</b>	88			
			1.09	I	16500 (73600)				1.09	I	16100 (71700)	15	<b>4D180</b>	88			
			1.09	I	21200 (94200)				1.09	I	21600 (96200)	15	<b>4E180</b>	88			
			1.29	I	21200 (94200)				1.29	I	21600 (96200)	15	<b>4E190</b>	88			
			1.29	I	29900 (133000)				1.29	I	30300 (135000)	15	<b>4F190</b>	88			
14.3	60000 (6780)		1.01	I	16500 (73300)	17.2	49700 (5620)		1.01	I	16500 (73200)	15	<b>4D170</b>	102			
			1.01	I	20800 (92400)				1.01	I	21300 (94700)	15	<b>4E170</b>	102			
			1.29	I	20800 (92400)				1.29	I	21300 (94700)	15	<b>4E190</b>	102	(-)		
			1.29	I	29600 (132000)				1.29	I	30000 (134000)	15	<b>4F190</b>	102	(-)		
12.9	66200 (7480)		0.88	-	15000 (66600)	15.6	54900 (6200)		0.88	-	16600 (74100)	15	<b>4D180</b>	112			
			0.88	-	20400 (91000)				0.88	-	21000 (93500)	15	<b>4E180</b>	112			
			1.09	I	20400 (91000)				1.09	I	21000 (93500)	15	<b>4E190</b>	112	(-)		
			1.09	I	29300 (130000)				1.09	I	29800 (133000)	15	<b>4F190</b>	112	(-)		
11.8	72400 (8180)		0.88	-	13100 (58400)	14.3	60000 (6780)		0.88	-	16500 (73300)	15	<b>4D180</b>	123			
			0.88	-	20100 (89600)				0.88	-	20800 (92400)	15	<b>4E180</b>	123			
			1.09	I	20100 (89600)				1.09	I	20800 (92400)	15	<b>4E190</b>	123	(-)		
			1.09	I	29000 (129000)				1.09	I	29600 (132000)	15	<b>4F190</b>	123	(-)		
9.63	89000 (10100)		0.88	-	19300 (85800)	11.6	73700 (8330)		0.88	-	20100 (89300)	15	<b>4E190</b>	151			
			0.88	-	28300 (126000)				0.88	-	29000 (129000)	15	<b>4F190</b>	151			

# Y4 Mounting Single Reduction Selection Tables

**20 HP**  
(15 kW)



Dimension Pages:

Single Reduction	2.132-2.143
Single Reduction, Y2	2.144
Double Reduction	2.146-2.161
Double Reduction, Y2	2.162

Frequency	50 Hz	60 Hz
Input Speed	1450 RPM	1750 RPM
Number of Poles	4	

50Hz					60 Hz					Selection							
Output Speed (RPM)	Output Torque		Service Factor		Solid Shaft Overhung Load		Output Speed (RPM)	Output Torque		Service Factor <sup>[1]</sup>		Solid Shaft Overhung Load		Base			VFD <sup>[1]</sup>
	in-lbs	(N·m)	SF	AGMA Class	lbs	(N)		in-lbs	(N·m)	SF	AGMA Class	lbs	(N)	Motor Power Code	Frame Size	Ratio	
64.7	18100 (2040)		1.01	I	4980 (22200)	78.1	15000 (1690)		1.01	I	4940 (22000)	20	<b>4B160</b>	22			
			1.01	I	7820 (34800)				1.01	I	7590 (33700)	20	<b>4C160</b>	22			
			1.01	I	12300 (54700)				1.01	I	11800 (52500)	20	<b>4D160</b>	22			
59.2	19800 (2230)		1.01	I	4990 (22200)	71.4	16400 (1850)		1.01	I	4970 (22100)	20	<b>4B160</b>	25			
			1.01	I	7920 (35200)				1.01	I	7700 (34300)	20	<b>4C160</b>	25			
			1.01	I	12500 (55800)				1.01	I	12000 (53500)	20	<b>4D160</b>	25			
51.8	22600 (2550)		1.01	I	4980 (22100)	62.5	18700 (2110)		1.01	I	4990 (22200)	20	<b>4B160</b>	28			
			1.01	I	8050 (35800)				1.01	I	7860 (35000)	20	<b>4C160</b>	28			
			1.01	I	12900 (57300)				1.01	I	12400 (55100)	20	<b>4D160</b>	28			
41.2	28400 (3210)		1.01	I	8220 (36600)	49.7	23500 (2660)		1.01	I	8080 (36000)	20	<b>4C160</b>	35			
			1.01	I	13500 (59900)				1.01	I	13000 (57800)	20	<b>4D160</b>	35			
			1.29	I	13500 (59900)				1.29	I	13000 (57800)	20	<b>4D180</b>	35	(-)		
			1.29	I	18100 (80700)				1.29	I	17400 (77300)	20	<b>4E180</b>	35	(-)		
			1.60	II	18100 (80700)				1.60	II	17400 (77300)	20	<b>4E190</b>	35			
			1.60	II	30900 (138000)				1.60	II	30000 (134000)	20	<b>4F190</b>	35			
37.7	31000 (3510)		1.01	I	8270 (36800)	45.5	25700 (2910)		1.01	I	8160 (36300)	20	<b>4C160</b>	39			
			1.01	I	13700 (60900)				1.01	I	13200 (58800)	20	<b>4D160</b>	39			
			1.29	I	13700 (60900)				1.29	I	13200 (58800)	20	<b>4D180</b>	39	(-)		
			1.29	I	18500 (82200)				1.29	I	17700 (78900)	20	<b>4E180</b>	39	(-)		
			1.60	II	18500 (82200)				1.60	II	17700 (78900)	20	<b>4E190</b>	39			
			1.60	II	30800 (137000)				1.60	II	30800 (137000)	20	<b>4F190</b>	39			
31.9	36700 (4140)		0.95	-	8310 (37000)	38.5	30400 (3430)		0.95	-	8260 (36700)	20	<b>4C170</b>	46			
			0.95	-	14100 (62500)				0.95	-	13600 (60600)	20	<b>4D170</b>	46			
			1.29	I	14100 (62500)				1.29	I	13600 (60600)	20	<b>4D180</b>	46	(-)		
			1.29	I	19100 (85200)				1.29	I	18400 (81900)	20	<b>4E180</b>	46	(-)		
			1.60	II	19100 (85200)				1.60	II	18400 (81900)	20	<b>4E190</b>	46			
			1.60	II	30600 (136000)				1.60	II	30900 (137000)	20	<b>4F190</b>	46			
27.6	42300 (4780)		0.80	-	8290 (36900)	33.3	35100 (3960)		0.80	-	8300 (36900)	20	<b>4C170</b>	53			
			0.80	-	14400 (63800)				0.80	-	14000 (62100)	20	<b>4D170</b>	53			
			0.95	-	14400 (63800)				0.95	-	14000 (62100)	20	<b>4D180</b>	53	(-)		
			0.95	-	19700 (87600)				0.95	-	19000 (84400)	20	<b>4E180</b>	53	(-)		
			1.60	II	19700 (87600)				1.60	II	19000 (84400)	20	<b>4E190</b>	53			
			1.60	II	30300 (135000)				1.60	II	30700 (136000)	20	<b>4F190</b>	53			
24.4	48000 (5420)		0.95	-	14600 (64800)	29.4	39700 (4490)		0.95	-	14200 (63300)	20	<b>4D180</b>	60			
			0.95	-	20100 (89600)				0.95	-	19400 (86500)	20	<b>4E180</b>	60			
			1.60	II	20100 (89600)				1.60	II	19400 (86500)	20	<b>4E190</b>	60			
			1.60	II	30100 (134000)				1.60	II	30400 (135000)	20	<b>4F190</b>	60			

Notes: [1] For double reduction and 1/8 HP single reduction Y4 ratings, refer to selection tables on pages 2.91 thru 2.130.  
[2] Variable Frequency Drive (VFD) notes (see page 2.8 for Constant Torque Speed Ranges):

Notes: [1] For double reduction and 1/8 HP single reduction Y4 ratings, refer to selection tables on pages 2.91 thru 2.130.  
[2] Variable Frequency Drive (VFD) notes (see page 2.8 for Constant Torque Speed Ranges):

# Y4 Mounting Single Reduction Selection Tables

**20 HP  
(15 kW)**

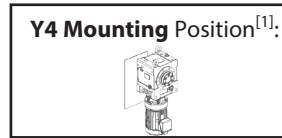

Dimension Pages:

Single Reduction	2.132-2.143
Single Reduction, Y2	2.144
Double Reduction	2.146-2.161
Double Reduction, Y2	2.162

Frequency	50 Hz	60 Hz
Input Speed	1450 RPM	1750 RPM
Number of Poles	4	

50Hz					60 Hz					Selection							
Output Speed (RPM)	Output Torque		Service Factor		Solid Shaft Overhung Load		Output Speed (RPM)	Output Torque		Service Factor <sup>[1]</sup>		Solid Shaft Overhung Load		Base			VFD <sup>[1]</sup>
	in-lbs	(N·m)	SF	AGMA Class	lbs	(N)		in-lbs	(N·m)	SF	AGMA Class	lbs	(N)	Motor Power Code	Frame Size	Ratio	
21.6	54200 (6120)		0.95	-	14800 (65700)	26.0	44900 (5070)		0.95	-	14500 (64300)	20	<b>4D180</b>	67			
			0.95	-	20600 (91500)				0.95	-	19900 (88500)	20	<b>4E180</b>	67			
			0.95	-	29800 (133000)				0.95	-	30200 (134000)	20	<b>4F180</b>	67			
19.7	59300 (6690)		0.95	-	14900 (66200)	23.8	49100 (5550)		0.95	-	14600 (65000)	20	<b>4D180</b>	74			
			0.95	-	20800 (92500)				0.95	-	20200 (90000)	20	<b>4E180</b>	74			
			0.95	-	29600 (132000)				0.95	-	30000 (134000)	20	<b>4F180</b>	74			
18.1	64500 (7290)		0.80	-	15000 (66500)	21.9	53400 (6040)		0.80	-	14700 (65600)	20	<b>4D180</b>	80			
			0.80	-	20500 (91400)				0.80	-	20500 (91300)	20	<b>4E180</b>	80			
			0.95	-	20500 (91400)				0.95	-	20500 (91300)	20	<b>4E190</b>	80	(-)		
			0.95	-	29400 (131000)				0.95	-	29900 (133000)	20	<b>4F190</b>	80	(-)		
16.6	70500 (7970)		0.80	-	13700 (61100)	20.0	58400 (6600)		0.80	-	14900 (66100)	20	<b>4D180</b>	88			
			0.80	-	20200 (90000)				0.80	-	20800 (92600)	20	<b>4E180</b>	88			
			0.95	-	20200 (90000)				0.95	-	20800 (92600)	20	<b>4E190</b>	88	(-)		
			0.95	-	29100 (130000)				0.95	-	29600 (132000)	20	<b>4F190</b>	88	(-)		
14.3	81800 (9250)		0.95	-	19700 (87400)	17.2	67800 (7660)		0.95	-	20400 (90600)	20	<b>4E190</b>	102			
			0.95	-	28600 (127000)				0.95	-	29200 (130000)	20	<b>4F190</b>	102			
12.9	90300 (10200)		0.80	-	19200 (85500)	15.6	74800 (8450)		0.80	-	20000 (89000)	20	<b>4E190</b>	112			
			0.80	-	28300 (126000)				0.80	-	28900 (129000)	20	<b>4F190</b>	112			
11.8	98800 (11200)		0.80	-	18800 (83600)	14.3	81800 (9250)		0.80	-	19700 (87400)	20	<b>4E190</b>	123			
			0.80	-	27900 (124000)				0.80	-	28600 (127000)	20	<b>4F190</b>	123			

Notes: [1] For double reduction and 1/8 HP single reduction Y4 ratings, refer to selection tables on pages 2.91 thru 2.130.  
[2] Variable Frequency Drive (VFD) notes (see page 2.8 for Constant Torque Speed Ranges):

# Y4 Mounting Single Reduction Selection Tables

**25 HP  
(18.5 kW)**

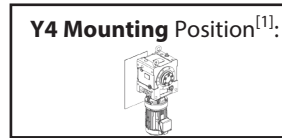

Dimension Pages:

Single Reduction	2.132-2.143
Single Reduction, Y2	2.144
Double Reduction	2.146-2.161
Double Reduction, Y2	2.162

Frequency	50 Hz	60 Hz
Input Speed	1450 RPM	1750 RPM
Number of Poles	4	

50Hz					60 Hz					Selection							
Output Speed (RPM)	Output Torque		Service Factor		Solid Shaft Overhung Load		Output Speed (RPM)	Output Torque		Service Factor <sup>[1]</sup>		Solid Shaft Overhung Load		Base			VFD <sup>[1]</sup>
	in-lbs	(N·m)	SF	AGMA Class	lbs	(N)		in-lbs	(N·m)	SF	AGMA Class	lbs	(N)	Motor Power Code	Frame Size	Ratio	
64.7	22300 (2520)		0.82	-	4530 (20100)	78.1	18500 (2090)		0.82	-	4560 (20300)	25	<b>4B160</b>	22			
			0.82	-	7420 (33000)				0.82	-	7260 (32300)	25	<b>4C160</b>	22			
			0.82	-	12000 (53200)				0.82	-	11500 (51200)	25	<b>4D160</b>	22			
59.2	24400 (2750)		0.82	-	4490 (20000)	71.4	20200 (2280)		0.82	-	4550 (20300)	25	<b>4B160</b>	25			
			0.82	-	7480 (33300)				0.82	-	7340 (32600)	25	<b>4C160</b>	25			
			0.82	-	12200 (54100)				0.82	-	11700 (52200)	25	<b>4D160</b>	25			
51.8	27800 (3150)		0.82	-	7550 (33600)	62.5	23100 (2610)		0.82	-	7440 (33100)	25	<b>4C160</b>	28			
			0.82	-	12500 (55400)				0.82	-	12000 (53600)	25	<b>4D160</b>	28			
41.2	35000 (3950)		0.82	-	7590 (33800)	49.7	29000 (3280)		0.82	-	7560 (33600)	25	<b>4C160</b>	35			
			0.82	-	12900 (57500)				0.82	-	12600 (55800)	25	<b>4D160</b>	35			
			1.05	I	12900 (57500)				1.05	I	12600 (55800)	25	<b>4D180</b>	35			
			1.05	I	17600 (78500)				1.05	I	17000 (75500)	25	<b>4E180</b>	35			
			1.29	I	17600 (78500)				1.29	I	17000 (75500)	25	<b>4E190</b>	35	(-)		
37.7	38300 (4330)		0.82	-	7580 (33700)	45.5	31700 (3580)		0.82	-	7590 (33800)	25	<b>4C160</b>	39			
			0.82	-	13100 (58300)				0.82	-	12700 (56700)	25	<b>4D160</b>	39			
			1.05	I	13100 (58300)				1.05	I	12700 (56700)	25	<b>4D180</b>	39			
			1.05	I	18000 (79900)				1.05	I	17300 (77000)	25	<b>4E180</b>	39			
			1.29	I	18000 (79900)				1.29	I	17300 (77000)	25	<b>4E190</b>	39	(-)		
31.9	45200 (5110)		0.77	-	7500 (33400)	38.5	37500 (4240)		0.77	-	7590 (33800)	25	<b>4C170</b>	46			
			0.77	-	13400 (59500)				0.77	-	13100 (58100)	25	<b>4D170</b>	46			
			1.05	I	13400 (59500)				1.05	I	13100 (58100)	25	<b>4D180</b>	46			
			1.05	I	18500 (82400)				1.05	I	17900 (79600)	25	<b>4E180</b>	46			
			1.29	I	18500 (82400)				1.29	I	17900 (79600)	25	<b>4E190</b>	46	(-)		
27.6	52200 (5900)		0.77	-	13600 (60300)	33.3	43300 (4890)		0.77	-	13300 (59200)	25	<b>4D180</b>	53			
			0.77	-	19000 (84400)				0.77	-	18400 (81700)	25	<b>4E180</b>	53			
			1.29	I	19000 (84400)				1.29	I	18400 (81700)	25	<b>4E190</b>	53	(-)		
			1.29	I	29900 (133000)				1.29	I	30300 (135000)	25	<b>4F190</b>	53	(-)		
24.4	59200 (6680)		0.77	-	13700 (60800)	29.4	49000 (5540)		0.77	-	13500 (60000)	25	<b>4D180</b>	60			
			0.77	-	19300 (86000)				0.77	-	18800 (83500)	25	<b>4E180</b>	60			
			1.29	I	19300 (86000)				1.29	I	18800 (83500)	25	<b>4E190</b>	60	(-)		
			1.29	I	29600 (132000)				1.29	I	30000 (134000)	25	<b>4F190</b>	60	(-)		
21.6	66800 (7550)		0.77	-	13700 (61100)	26.0	55400 (6260)		0.77	-	13600 (60600)	25	<b>4D180</b>	67			
			0.77	-	19600 (87400)				0.77	-	19100 (85100)	25	<b>4E180</b>	67			
			0.77	-	29300 (130000)				0.77	-	29800 (132000)	25	<b>4F180</b>	67			

Notes: [1] For double reduction and 1/8 HP single reduction Y4 ratings, refer to selection tables on pages 2.91 thru 2.130.  
[2] Variable Frequency Drive (VFD) notes (see page 2.8 for Constant Torque Speed Ranges):

# Y4 Mounting Single Reduction Selection Tables

**25 HP**  
(18.5 kW)

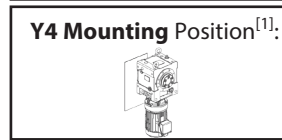

Dimension Pages:

Single Reduction	2.132-2.143
Single Reduction, Y2	2.144
Double Reduction	2.146-2.161
Double Reduction, Y2	2.162

Frequency	50 Hz	60 Hz
Input Speed	1450 RPM	1750 RPM
Number of Poles	4	

50Hz					60 Hz					Selection							
Output Speed (RPM)	Output Torque		Service Factor		Solid Shaft Overhung Load		Output Speed (RPM)	Output Torque		Service Factor <sup>[1]</sup>		Solid Shaft Overhung Load		Base			VFD <sup>[1]</sup>
	in-lbs	(N·m)	SF	AGMA Class	lbs	(N)		in-lbs	(N·m)	SF	AGMA Class	lbs	(N)	Motor Power Code	Frame Size	Ratio	
19.7	73100 (8260)		0.77	-	12900 (57400)	23.8	60600 (6840)		0.77	-	13700 (60900)	25	<b>4D180</b>	74			
			0.77	-	19900 (88300)				0.77	-	19400 (86200)	25	<b>4E180</b>	74			
			0.77	-	29000 (129000)				0.77	-	29600 (131000)	25	<b>4F180</b>	74			
18.1	79500 (8990)		0.77	-	19800 (88000)	21.9	65900 (7450)		0.77	-	19600 (87200)	25	<b>4E190</b>	80			
			0.77	-	28700 (128000)				0.77	-	29300 (130000)	25	<b>4F190</b>	80			
16.6	87000 (9830)		0.77	-	19400 (86300)	20.0	72100 (8140)		0.77	-	19800 (88200)	25	<b>4E190</b>	88			
			0.77	-	28400 (126000)				0.77	-	29100 (129000)	25	<b>4F190</b>	88			
14.3	101000 (11400)		0.77	-	18700 (83100)	17.2	83600 (9450)		0.77	-	19600 (87000)	25	<b>4E190</b>	102			
			0.77	-	27800 (124000)				0.77	-	28600 (127000)	25	<b>4F190</b>	102			

# Y4 Mounting Single Reduction Selection Tables

**30 HP**  
(22 kW)

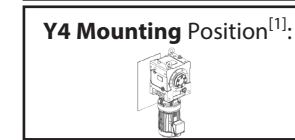

Dimension Pages:

Single Reduction	2.132-2.143
Single Reduction, Y2	2.144
Double Reduction	2.146-2.161
Double Reduction, Y2	2.162

Frequency	50 Hz	60 Hz
Input Speed	1450 RPM	1750 RPM
Number of Poles	4	

50Hz					60 Hz					Selection							
Output Speed (RPM)	Output Torque		Service Factor		Solid Shaft Overhung Load		Output Speed (RPM)	Output Torque		Service Factor <sup>[1]</sup>		Solid Shaft Overhung Load		Base			VFD <sup>[1]</sup>
	in-lbs	(N·m)	SF	AGMA Class	lbs	(N)		in-lbs	(N·m)	SF	AGMA Class	lbs	(N)	Motor Power Code	Frame Size	Ratio	
41.2	41600 (4700)		0.88	-	12400 (55200)	49.7	34500 (3900)		0.88	-	12100 (53900)	30	<b>4D180</b>	35			
			0.88	-	17200 (76300)				0.88	-	16600 (73700)	30	<b>4E180</b>	35			
			1.09	I	17200 (76300)				1.09	I	16600 (73700)	30	<b>4E190</b>	35	(-)		
			1.09	I	30400 (135000)				1.09	I	29300 (130000)	30	<b>4F190</b>	35	(-)		
37.7	45500 (5140)		0.88	-	12500 (55700)	45.5	37700 (4260)		0.88	-	12300 (54500)	30	<b>4D180</b>	39			
			0.88	-	17400 (77500)				0.88	-	16900 (75000)	30	<b>4E180</b>	39			
			1.09	I	17400 (77500)				1.09	I	16900 (75000)	30	<b>4E190</b>	39	(-)		
			1.09	I	30200 (134000)				1.09	I	30000 (133000)	30	<b>4F190</b>	39	(-)		
31.9	53800 (6080)		0.88	-	12700 (56400)	38.5	44600 (5040)		0.88	-	12500 (55600)	30	<b>4D180</b>	46			
			0.88	-	17900 (79600)				0.88	-	17400 (77200)	30	<b>4E180</b>	46			
			1.09	I	17900 (79600)				1.09	I	17400 (77200)	30	<b>4E190</b>	46	(-)		
			1.09	I	29800 (133000)				1.09	I	30200 (135000)	30	<b>4F190</b>	46	(-)		
27.6	62100 (7010)		1.09	I	18200 (81100)	33.3	51400 (5810)		1.09	I	17800 (79000)	30	<b>4E190</b>	53	(-)		
			1.09	I	29500 (131000)				1.09	I	29900 (133000)	30	<b>4F190</b>	53	(-)		
24.4	70400 (7950)		1.09	I	18500 (82300)	29.4	58300 (6590)		1.09	I	18100 (80500)	30	<b>4E190</b>	60	(-)		
			1.09	I	29100 (130000)				1.09	I	29600 (132000)	30	<b>4F190</b>	60	(-)		

Notes: [1] For double reduction and 1/8 HP single reduction Y4 ratings, refer to selection tables on pages 2.91 thru 2.130.  
[2] Variable Frequency Drive (VFD) notes (see page 2.8 for Constant Torque Speed Ranges):

Notes: [1] For double reduction and 1/8 HP single reduction Y4 ratings, refer to selection tables on pages 2.91 thru 2.130.  
[2] Variable Frequency Drive (VFD) notes (see page 2.8 for Constant Torque Speed Ranges):



# Y4 Mounting Single Reduction Selection Tables

**40 HP  
(30 kW)**

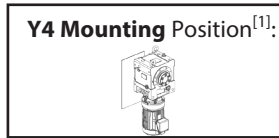

Dimension Pages:

Single Reduction	2.132-2.143
Single Reduction, Y2	2.144
Double Reduction	2.146-2.161
Double Reduction, Y2	2.162

Frequency	50 Hz	60 Hz
Input Speed	1450 RPM	1750 RPM
Number of Poles	4	

Page intentionally left blank.

50Hz				60 Hz				Selection			VFD <sup>[1]</sup>					
Output Speed (RPM)	Output Torque		Service Factor		Solid Shaft Overhung Load		Output Speed (RPM)	Output Torque		Service Factor <sup>[1]</sup>		Solid Shaft Overhung Load		Base		
	in-lbs	(N·m)	SF	AGMA Class	lbs	(N)		in-lbs	(N·m)	SF	AGMA Class	lbs	(N)	Motor Power Code	Frame Size	Ratio
41.2	56800 (6410)		0.80	-	16000 (71400)	49.7	47000 (5310)		0.80	-	15700 (69600)	40	4E190	35	(-)	
			0.80	-	29700 (132000)				0.80	-	28500 (127000)					
37.7	62100 (7010)		0.80	-	16200 (72100)	45.5	51400 (5810)		0.80	-	15900 (70500)	40	4E190	39	(-)	
			0.80	-	29500 (131000)				0.80	-	29100 (129000)					
31.9	73400 (8290)		0.80	-	16500 (73200)	38.5	60800 (6870)		0.80	-	16200 (72000)	40	4E190	46		
			0.80	-	29000 (129000)				0.80	-	29500 (131000)					
27.6	84700 (9560)		0.80	-	16600 (73800)	33.3	70100 (7920)		0.80	-	16400 (72900)	40	4E190	53		
			0.80	-	28500 (127000)				0.80	-	29100 (130000)					
24.4	95900 (10800)		0.80	-	16600 (74000)	29.4	79500 (8980)		0.80	-	16500 (73600)	40	4E190	60		
			0.80	-	28000 (125000)				0.80	-	28700 (128000)					

Cyclo® BBB4

Selection Tables

Notes: [1] For double reduction and 1/8 HP single reduction Y4 ratings, refer to selection tables on pages 2.91 thru 2.130.  
 [2] Variable Frequency Drive (VFD) notes (see page 2.8 for Constant Torque Speed Ranges):

# Dimensions

## Single Reduction Cyclo® LHYM-4A100Y~4A125Y

Minimum Engagement		
Frame Size	TT	
	inch	(mm)
4A	8.19	(208)

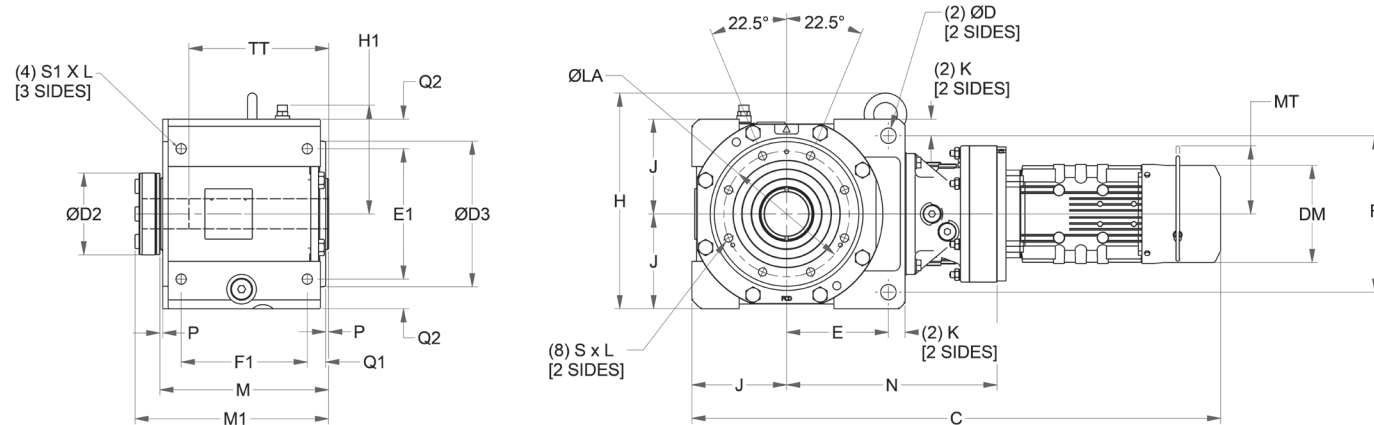
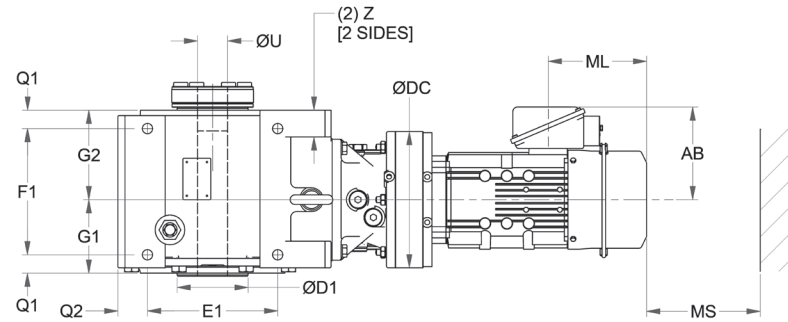

All dimensions are in inches (mm).  
For units ordered in the Y2 mounting configuration, please refer to page 2.115 for external lubricant piping dimensions.

Model	N	ØDC	J	E	F	K	Z	ØD	E1	F1	Q1	Q2	S1 x L
4A100, 4A105	9.33 (237)	5.91 (150)	4.33 (110)	4.49 (114)	7.24 (184)	0.71 (18)	1.38 (35)	0.71 (18)	5.91 (150)	6.30 (160)	0.91 (23)	1.38 (35)	M12 x 0.79 (M12 x 20)
4A110, 4A115	9.76 (248)	6.38 (162)											
4A120, 4A125	9.57 (243)	8.03 (204)											

Model	M	P	G1	G2	H	H1	ØLA	ØD3	S x L	M1	ØD1	ØD2	ØU	
													Std & Max	Min
4A100, 4A105 4A110, 4A115 4A120, 4A125	8.50 (216)	0.2 (5)	3.78 (96)	4.33 (110)	10.9 (276)	5.16 (131)	6.10 (155)	6.89 (175)	M10 x 0.67 (M10 x 17)	9.84 (250)	3.4 (85)	4.09 (104)	2-3/16 (55.56)	1-11/16 (42.86)

## LHYM01-4A105Y-AV ▶ LHYM2-4A125Y-EP

All dimensions are in inches (mm)

Model	4 Pole Motor HP (kW)	Without Brake					With Brake						
		C	DM <sup>[1]</sup>	AB	ML	Weight lb (kg)	C	DM <sup>[1]</sup>	AB	ML	MS	MT	Weight lb (kg)
LHYM01-4A105Y-AV	1/8 x 4 (0.1 x 4)	20.58 (523)	ø4.88 (ø124)	4.63 (118)	2.32 (59)	117 (53)	21.84 (555)	ø4.88 (ø124)	4.63 (118)	3.58 (91)	2.40 (61)	-	120 (55)
LHYM02-4A105Y	1/4 x 4 (0.2 x 4)	20.58 (523)	ø4.88 (ø124)	4.63 (118)	2.32 (59)	117 (53)	21.84 (555)	ø4.88 (ø124)	4.63 (118)	3.58 (91)	2.40 (61)	-	120 (55)
LHYM02-4A105Y-AV	1/4 x 4 (0.2 x 4)	21.37 (543)	ø4.88 (ø124)	4.63 (118)	2.32 (59)	120 (55)	22.63 (575)	ø4.88 (ø124)	4.63 (118)	3.58 (91)	2.40 (61)	-	123 (56)
LHYM03-4A105Y	1/3 x 4 (0.25 x 4)	20.58 (523)	ø4.88 (ø124)	4.63 (118)	2.32 (59)	117 (53)	21.84 (555)	ø4.88 (ø124)	4.63 (118)	3.58 (91)	2.40 (61)	-	120 (55)
LHYM03-4A105Y-AV	1/3 x 4 (0.25 x 4)	21.37 (543)	ø4.88 (ø124)	4.63 (118)	2.32 (59)	120 (55)	22.63 (575)	ø4.88 (ø124)	4.63 (118)	3.58 (91)	2.40 (61)	-	123 (56)
LHYM05-4A105Y	1/2 x 4 (0.4 x 4)	21.37 (543)	ø4.88 (ø124)	4.63 (118)	2.32 (59)	120 (55)	22.63 (575)	ø4.88 (ø124)	4.63 (118)	3.58 (91)	2.40 (61)	-	123 (56)
LHYM05-4A105Y-AV	1/2 x 4 (0.4 x 4)	22.98 (584)	ø5.94 (ø151)	5.67 (144)	3.82 (97)	127 (58)	24.68 (627)	ø5.94 (ø151)	5.67 (144)	5.51 (140)	3.66 (93)	3.94 (100)	133 (61)
LHYM08-4A105Y	3/4 x 4 (0.55 x 4)	22.98 (584)	ø5.94 (ø151)	5.67 (144)	3.82 (97)	124 (57)	24.68 (627)	ø5.94 (ø151)	5.67 (144)	5.51 (140)	3.66 (93)	3.94 (100)	130 (59)
LHYM08-4A105Y-AV	3/4 x 4 (0.55 x 4)	24.28 (617)	ø6.30 (ø160)	5.86 (149)	3.94 (100)	135 (62)	26.72 (679)	ø6.30 (ø160)	5.86 (149)	6.38 (162)	4.53 (115)	4.29 (109)	146 (66)
LHYM1-4A105Y-EP	1 x 4 (0.75 x 4)	24.72 (628)	6.22 (158)	5.98 (152)	3.82 (97)	140 (64)	27.22 (691)	6.22 (158)	5.98 (152)	6.32 (161)	4.80 (122)	4.25 (108)	150 (68)
LHYM1H-4A105Y-EP	1.5 x 4 (1.1 x 4)	25.78 (655)	6.57 (167)	6.16 (156)	3.82 (97)	148 (67)	28.52 (724)	6.57 (167)	6.16 (156)	6.56 (167)	5.04 (128)	4.61 (117)	159 (72)
LHYM2-4A105Y-EP	2 x 4 (1.5 x 4)	25.78 (655)	6.57 (167)	6.16 (156)	3.82 (97)	150 (69)	28.52 (724)	6.57 (167)	6.16 (156)	6.56 (167)	5.04 (128)	4.61 (117)	162 (74)
LHYM3-4A105Y-EP	3 x 4 (2.2 x 4)	26.61 (676)	7.24 (184)	6.71 (170)	4.53 (115)	167 (76)	29.68 (754)	7.24 (184)	6.71 (170)	7.60 (193)	5.43 (138)	5.04 (128)	183 (83)
LHYM03-4A115Y-AV	1/3 x 4 (0.25 x 4)	21.66 (550)	ø4.88 (ø124)	4.63 (118)	2.32 (59)	135 (62)	22.92 (582)	ø4.88 (ø124)	4.63 (118)	3.58 (91)	2.40 (61)	-	138 (63)
LHYM05-4A115Y	1/2 x 4 (0.4 x 4)	21.66 (550)	ø4.88 (ø124)	4.63 (118)	2.32 (59)	135 (62)	22.92 (582)	ø4.88 (ø124)	4.63 (118)	3.58 (91)	2.40 (61)	-	138 (63)
LHYM05-4A115Y-AV	1/2 x 4 (0.4 x 4)	23.27 (591)	ø5.94 (ø151)	5.67 (144)	3.82 (97)	142 (65)	24.96 (634)	ø5.94 (ø151)	5.67 (144)	5.51 (140)	3.66 (93)	3.94 (100)	148 (67)
LHYM08-4A115Y	3/4 x 4 (0.55 x 4)	23.27 (591)	ø5.94 (ø151)	5.67 (144)	3.82 (97)	139 (63)	24.96 (634)	ø5.94 (ø151)	5.67 (144)	5.51 (140)	3.66 (93)	3.94 (100)	145 (66)
LHYM08-4A115Y-AV	3/4 x 4 (0.55 x 4)	24.57 (624)	ø6.30 (ø160)	5.86 (149)	3.94 (100)	148 (68)	27.01 (686)	ø6.30 (ø160)	5.86 (149)	6.38 (162)	4.53 (115)	4.29 (109)	159 (72)
LHYM1-4A115Y-EP	1 x 4 (0.75 x 4)	25.00 (635)	6.22 (158)	5.98 (152)	3.82 (97)	153 (70)	27.50 (699)	6.22 (158)	5.98 (152)	6.32 (161)	4.80 (122)	4.25 (108)	163 (74)
LHYM1H-4A115Y-EP	1.5 x 4 (1.1 x 4)	26.07 (662)	6.57 (167)	6.16 (156)	3.82 (97)	160 (73)	28.80 (732)	6.57 (167)	6.16 (156)	6.56 (167)	5.04 (128)	4.61 (117)	172 (78)
LHYM2-4A115Y-EP	2 x 4 (1.5 x 4)	26.07 (662)	6.57 (167)	6.16 (156)	3.82 (97)	163 (74)	28.80 (732)	6.57 (167)	6.16 (156)	6.56 (167)	5.04 (128)	4.61 (117)	175 (80)
LHYM3-4A115Y-EP	3 x 4 (2.2 x 4)	25.95 (659)	7.24 (184)	6.71 (170)	4.53 (115)	175 (80)	29.02 (737)	7.24 (184)	6.71 (170)	7.60 (193)	5.43 (138)	5.04 (128)	192 (87)
LHYM5-4A115Y-EP	5 x 4 (3.7 x 4)	27.01 (686)	8.74 (222)	7.34 (186)	4.65 (118)	201 (91)	30.57 (777)	8.74 (222)	7.34 (186)	8.21 (209)	6.02 (153)	6.30 (160)	225 (102)
LHYM1-4A125Y-EP	1 x 4 (0.75 x 4)	24.96 (634)	6.22 (158)	5.98 (152)	3.82 (97)	157 (71)	27.46 (698)	6.22 (158)	5.98 (152)	6.32 (161)	4.80 (122)	4.25 (108)	167 (76)
LHYM1H-4A125Y-EP	1.5 x 4 (1.1 x 4)	26.03 (661)	6.57 (167)	6.16 (156)	3.82 (97)	164 (75)	28.76 (731)	6.57 (167)	6.16 (156)	6.56 (167)	5.04 (128)	4.61 (117)	175 (80)
LHYM2-4A125Y-EP	2 x 4 (1.5 x 4)	26.03 (661)	6.57 (167)	6.16 (156)	3.82 (97)	167 (76)	28.76 (731)	6.57 (167)	6.16 (156)	6.56 (167)	5.04 (128)	4.61 (117)	178 (81)

Notes [1]: DM Dimension Symbol ø = Round Fan Cover  
DM Dimension Symbol = Square Fan Cover

LXXX-4XX0/4XX5 Frame sizes have equal dimensions, different ratings.

# Dimensions

## Single Reduction Cyclo® LHYM-4A120Y~4B145Y

Minimum Engagement		
Frame Size	TT	
	inch	(mm)
4A	8.19	(208)
4B	9.53	(242)

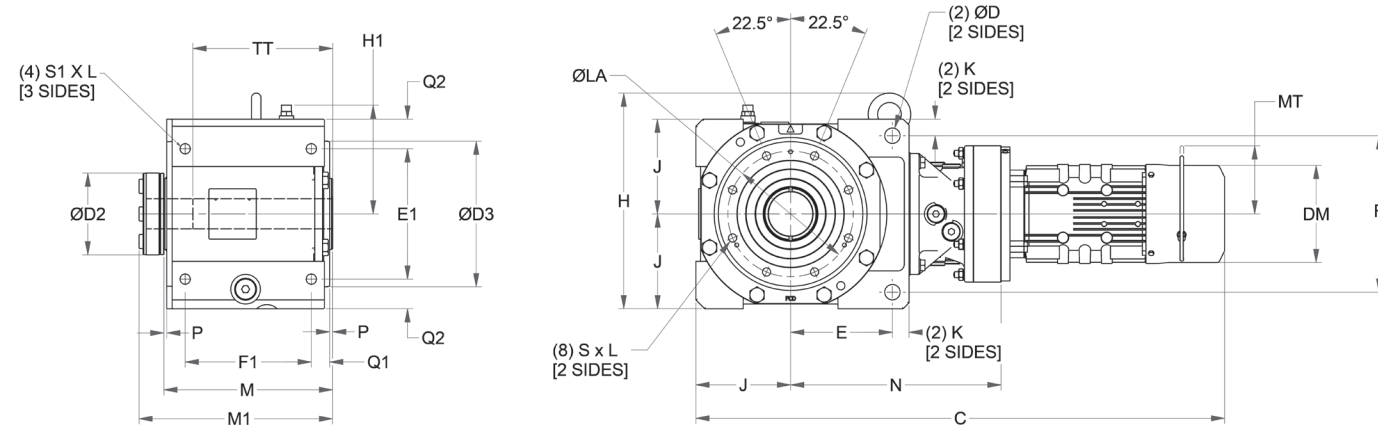
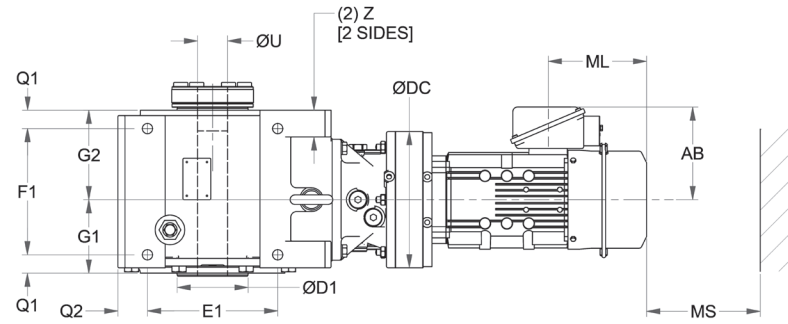

All dimensions are in inches (mm).  
For units ordered in the Y2 mounting configuration, please refer to page 2.115 for external lubricant piping dimensions.

Model	N	ØDC	J	E	F	K	Z	ØD	E1	F1	Q1	Q2	S1 x L
4A120, 4A125	9.57 (243)	8.03 (204)	4.33 (110)	4.49 (114)	7.24 (184)	0.71 (18)	1.38 (25)	0.71 (18)	5.91 (150)	6.30 (160)	0.91 (23)	1.38 (35)	M12 x 0.79 (M12 x 20)
4A140, 4A145	10.2 (265)	9.06 (230)											
4B120, 4B125	11.02 (280)	8.03 (204)	5.12 (130)	5.59 (142)	8.43 (214)	0.91 (23)	1.58 (40)	0.87 (22)	7.48 (190)	7.68 (195)	1.06 (27)	1.38 (35)	M16 x 1.02 (M16 x 26)
4B140, 4B145	11.69 (297)	9.06 (230)											

Model	M	P	G1	G2	H	H1	ØLA	ØD3	S x L	M1	ØD1	ØD2	ØU	
													Std & Max	Min
4B120, 4B125 4B140, 4B145	10.20 (259)	0.20 (5)	4.80 (122)	5.00 (127)	12.13 (308)	5.94 (151)	6.89 (175)	7.83 (199)	M12 x 0.79 (M12 x 20)	11.54 (293)	3.94 (100)	4.49 (114)	2-7/16 (61.91)	1-15/16 (49.21)
4B120, 4B125 4B140, 4B145	10.20 (259)	0.20 (5)	4.80 (122)	5.00 (127)	12.13 (308)	5.94 (151)	6.89 (175)	7.83 (199)	M12 x 0.79 (M12 x 20)	11.54 (293)	3.94 (100)	4.49 (114)	2-7/16 (61.91)	1-15/16 (49.21)

## LHYM3-4A125Y-EP ▶ LHYM10-4B145Y-EP

All dimensions are in inches (mm)

Model	4 Pole Motor HP (kW)	Without Brake					With Brake						
		C	DM <sup>[1]</sup>	AB	ML	Weight lb (kg)	C	DM <sup>[1]</sup>	AB	ML	MS	MT	Weight lb (kg)
LHYM3-4A125Y-EP	3 x 4 (2.2 x 4)	25.44 (646)	7.24 (184)	6.71 (170)	4.53 (115)	180 (82)	28.51 (724)	7.24 (184)	6.71 (170)	7.60 (193)	5.43 (138)	5.04 (128)	197 (89)
LHYM5-4A125Y-EP	5 x 4 (3.7 x 4)	26.89 (683)	8.74 (222)	7.34 (186)	4.65 (118)	205 (93)	30.46 (774)	8.74 (222)	7.34 (186)	8.21 (209)	6.02 (153)	6.30 (160)	229 (104)
LHYM8-4A125Y-EP	7.5 x 4 (5.5 x 4)	28.59 (726)	8.74 (222)	7.34 (186)	4.65 (118)	239 (109)	32.15 (817)	8.74 (222)	7.34 (186)	8.21 (209)	6.02 (153)	6.30 (160)	263 (120)
LHYM3-4A145Y-EP	3 x 4 (2.2 x 4)	26.29 (668)	7.24 (184)	6.71 (170)	4.53 (115)	195 (89)	29.36 (746)	7.24 (184)	6.71 (170)	7.60 (193)	5.43 (138)	5.04 (128)	212 (96)
LHYM5-4A145Y-EP	5 x 4 (3.7 x 4)	27.55 (700)	8.74 (222)	7.34 (186)	4.65 (118)	219 (100)	31.11 (790)	8.74 (222)	7.34 (186)	8.21 (209)	6.02 (153)	6.30 (160)	243 (111)
LHYM8-4A145Y-EP	7.5 x 4 (5.5 x 4)	29.24 (743)	8.74 (222)	7.34 (186)	4.65 (118)	253 (115)	32.80 (833)	8.74 (222)	7.34 (186)	8.21 (209)	6.02 (153)	6.30 (160)	277 (126)
LHYM10-4A145Y-EP	10 x 4 (7.5 x 4)	30.74 (781)	10.24 (260)	9.04 (230)	5.43 (138)	280 (127)	34.87 (886)	10.24 (260)	9.04 (230)	9.57 (243)	7.44 (189)	7.32 (186)	324 (147)
LHYM15-4A145Y-EP	15 x 4 (11 x 4)	33.18 (843)	10.24 (260)	9.04 (230)	5.43 (138)	293 (133)	37.31 (948)	10.24 (260)	9.04 (230)	9.57 (243)	7.44 (189)	7.32 (186)	337 (153)
LHYM20-4A145Y-EP	20 x 4 (15 x 4)	35.62 (905)	ø12.49 (ø317)	10.26 (261)	7.01 (178)	373 (170)	40.91 (1039)	ø12.61 (ø320)	10.26 (261)	12.30 (313)	9.53 (242)	-	459 (209)
LHYM05-4B125Y	1/2 x 4 (0.4 x 4)	24.05 (611)	ø4.88 (ø124)	4.63 (118)	2.32 (59)	204 (93)	25.31 (643)	ø4.88 (ø124)	4.63 (118)	3.58 (91)	2.40 (61)	-	207 (94)
LHYM05-4B125Y-AV	1/2 x 4 (0.4 x 4)	25.46 (647)	ø5.94 (ø151)	5.67 (144)	3.82 (97)	211 (96)	27.16 (690)	ø5.94 (ø151)	5.67 (144)	5.51 (140)	3.66 (93)	3.94 (100)	217 (99)
LHYM08-4B125Y	3/4 x 4 (0.55 x 4)	25.46 (647)	ø5.94 (ø151)	5.67 (144)	3.82 (97)	208 (95)	27.16 (690)	ø5.94 (ø151)	5.67 (144)	5.51 (140)	3.66 (93)	3.94 (100)	214 (97)
LHYM08-4B125Y-AV	3/4 x 4 (0.55 x 4)	26.76 (680)	ø6.30 (ø160)	5.86 (149)	3.94 (100)	217 (99)	29.20 (742)	ø6.30 (ø160)	5.86 (149)	6.38 (162)	4.53 (115)	4.29 (109)	227 (103)
LHYM1-4B125Y-EP	1 x 4 (0.75 x 4)	27.20 (691)	6.22 (158)	5.98 (152)	3.82 (97)	222 (101)	29.70 (754)	6.22 (158)	5.98 (152)	6.32 (161)	4.80 (122)	4.25 (108)	231 (105)
LHYM1H-4B125Y-EP	1.5 x 4 (1.1 x 4)	28.26 (718)	6.57 (167)	6.16 (156)	3.82 (97)	228 (104)	31.00 (787)	6.57 (167)	6.16 (156)	6.56 (167)	5.04 (128)	4.61 (117)	240 (109)
LHYM2-4B125Y-EP	2 x 4 (1.5 x 4)	28.26 (718)	6.57 (167)	6.16 (156)	3.82 (97)	231 (105)	31.00 (787)	6.57 (167)	6.16 (156)	6.56 (167)	5.04 (128)	4.61 (117)	243 (111)
LHYM3-4B125Y-EP	3 x 4 (2.2 x 4)	27.67 (703)	7.24 (184)	6.71 (170)	4.53 (115)	245 (111)	30.74 (781)	7.24 (184)	6.71 (170)	7.60 (193)	5.43 (138)	5.04 (128)	261 (119)
LHYM5-4B125Y-EP	5 x 4 (3.7 x 4)	29.13 (740)	8.74 (222)	7.34 (186)	4.65 (118)	270 (123)	32.69 (830)	8.74 (222)	7.34 (186)	8.21 (209)	6.02 (153)	6.30 (160)	294 (134)
LHYM8-4B125Y-EP	7.5 x 4 (5.5 x 4)	30.82 (783)	8.74 (222)	7.34 (186)	4.65 (118)	304 (138)	34.38 (873)	8.74 (222)	7.34 (186)	8.21 (209)	6.02 (153)	6.30 (160)	328 (149)
LHYM1-4B145Y-EP	1 x 4 (0.75 x 4)	27.89 (708)	6.22 (158)	5.98 (152)	3.82 (97)	241 (109)	30.39 (772)	6.22 (158)	5.98 (152)	6.32 (161)	4.80 (122)	4.25 (108)	250 (114)
LHYM1H-4B145Y-EP	1.5 x 4 (1.1 x 4)	28.95 (735)	6.57 (167)	6.16 (156)	3.82 (97)	247 (112)	31.69 (805)	6.57 (167)	6.16 (156)	6.56 (167)	5.04 (128)	4.61 (117)	259 (118)
LHYM2-4B145Y-EP	2 x 4 (1.5 x 4)	28.95 (735)	6.57 (167)	6.16 (156)	3.82 (97)	250 (114)	31.69 (805)	6.57 (167)	6.16 (156)	6.56 (167)	5.04 (128)	4.61 (117)	262 (119)
LHYM3-4B145Y-EP	3 x 4 (2.2 x 4)	28.36 (720)	7.24 (184)	6.71 (170)	4.53 (115)	262 (119)	31.43 (798)	7.24 (184)	6.71 (170)	7.60 (193)	5.43 (138)	5.04 (128)	279 (127)
LHYM5-4B145Y-EP	5 x 4 (3.7 x 4)	29.62 (752)	8.74 (222)	7.34 (186)	4.65 (118)	286 (130)	33.18 (843)	8.74 (222)	7.34 (186)	8.21 (209)	6.02 (153)	6.30 (160)	310 (141)
LHYM8-4B145Y-EP	7.5 x 4 (5.5 x 4)	31.31 (795)	8.74 (222)	7.34 (186)	4.65 (118)	320 (146)	34.88 (886)	8.74 (222)	7.34 (186)	8.21 (209)	6.02 (153)	6.30 (160)	344 (156)
LHYM10-4B145Y-EP	10 x 4 (7.5 x 4)	32.81 (833)	10.24 (260)	9.04 (230)	5.43 (138)	347 (158)	36.94 (938)	10.24 (260)	9.04 (230)	9.57 (243)	7.44 (189)	7.32 (186)	391 (178)
LHYM15-4B145Y-EP	15 x 4 (11 x 4)	35.25 (895)	10.24 (260)	9.04 (230)	5.43 (138)	360 (163)	39.38 (1000)	10.24 (260)	9.04 (230)	9.57 (243)	7.44 (189)	7.32 (186)	404 (184)

Notes [1]: DM Dimension Symbol ø = Round Fan Cover  
DM Dimension Symbol = Square Fan Cover

LXXX-4XX0/4XX5 Frame sizes have equal dimensions, different ratings.

# Dimensions

## LHYM15-4B145Y-EP ▶ LHYM30-4C165Y-EP

### Single Reduction Cyclo® LHYM-4B140Y~4C165Y

Minimum Engagement		
Frame Size	TT	
	inch	(mm)
4B	9.53	(242)
4C	10.98	(279)

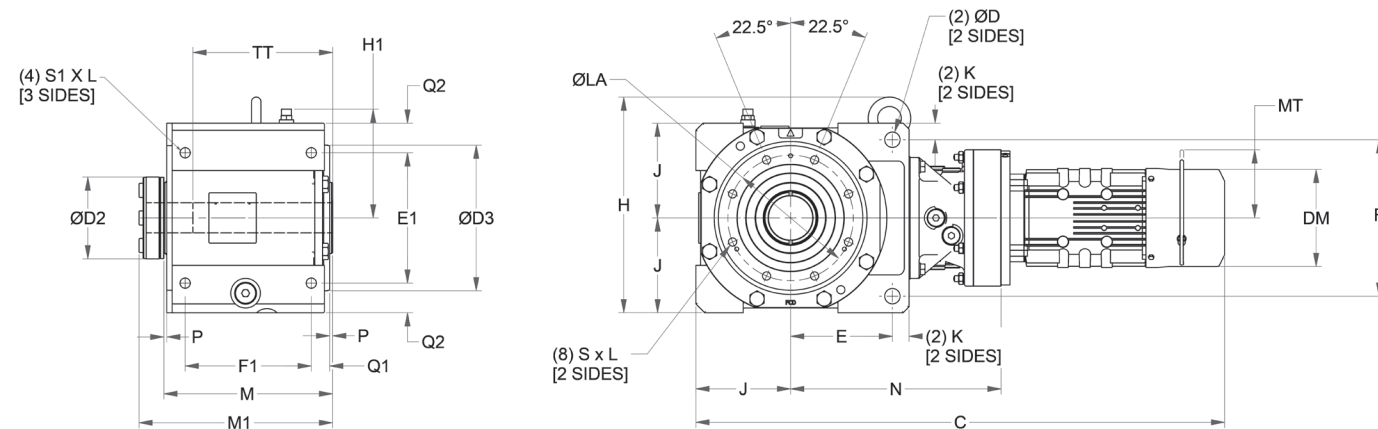
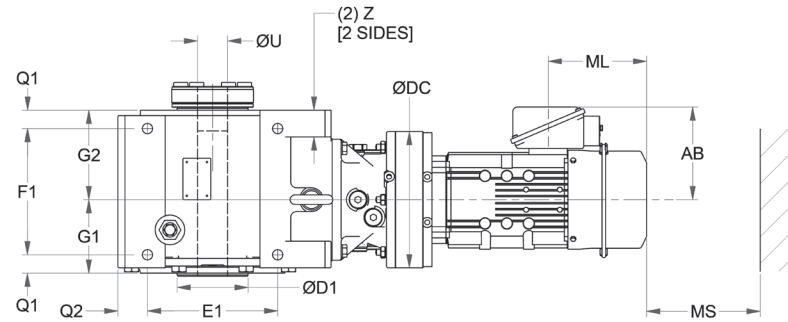

All dimensions are in inches (mm).  
For units ordered in the Y2 mounting configuration, please refer to page 2.115 for external lubricant piping dimensions.

Model	N	ØDC	J	E	F	K	Z	ØD	E1	F1	Q1	Q2	S1 x L
4B140, 4B145	11.69 (297)	9.06 (230)	5.12 (130)	5.59 (142)	8.43 (214)	0.91 (23)	1.58 (40)	0.87 (22)	7.48 (190)	7.68 (195)	1.06 (27)	1.38 (35)	M16 x 1.02 (M16 x 26)
4B160, 4B165	12.83 (326)	11.8 (300)											
4C140, 4C145	14.0 (356)	9.06 (230)	6.30 (160)	6.77 (172)	10.4 (264)	1.1 (28)	1.8 (45)	1.0 (26)	8.66 (220)	8.39 (213)	1.2 (31)	2.0 (50)	M20 x 1.30 (M20 x 33)
4C160, 4C165	14.8 (377)	11.8 (300)											

Model	M	P	G1	G2	H	H1	ØLA	ØD3	S x L	M1	ØD1	ØD2	ØU	
													Std & Max	Min
4B140, 4B145	10.20	0.20	4.80	5.00	12.13	5.94	6.89	7.83	M12 x 0.79	11.54	3.94	4.49	2-7/16	1-15/16
4B160, 4B165	(259)	(5)	(122)	(127)	(308)	(151)	(175)	(199)	(M12 x 20)	(293)	(100)	(114)	(61.91)	(49.21)
4C140, 4C145	11.2	0.2	4.88	5.94	14.33	7.20	8.35	9.61	M16 x 1.02	12.83	4.72	5.43	2-15/16	2-3/16
4C160, 4C165	(285)	(5)	(124)	(151)	(364)	(183)	(212)	(244)	(M16 x 26)	(326)	(120)	(138)	(74.61)	(55.56)

All dimensions are in inches (mm)

Model	4 Pole Motor HP (kW)	Without Brake					With Brake						
		C	DM <sup>[1]</sup>	AB	ML	Weight lb (kg)	C	DM <sup>[1]</sup>	AB	ML	MS	MT	Weight lb (kg)
LHYM20-4B145Y-EP	20 x 4 (15 x 4)	37.69 (957)	ø12.49 (ø317)	10.26 (261)	7.01 (178)	440 (200)	42.99 (1092)	ø12.61 (ø320)	10.26 (261)	12.30 (313)	9.53 (242)	-	526 (239)
LHYM10-4B165Y-EP	10 x 4 (7.5 x 4)	34.10 (866)	10.24 (260)	9.04 (230)	5.43 (138)	394 (179)	38.24 (971)	10.24 (260)	9.04 (230)	9.57 (243)	7.44 (189)	7.32 (186)	438 (199)
LHYM15-4B165Y-EP	15 x 4 (11 x 4)	36.54 (928)	10.24 (260)	9.04 (230)	5.43 (138)	407 (185)	40.68 (1033)	10.24 (260)	9.04 (230)	9.57 (243)	7.44 (189)	7.32 (186)	451 (205)
LHYM20-4B165Y-EP	20 x 4 (15 x 4)	38.83 (986)	ø12.49 (ø317)	10.26 (261)	7.01 (178)	490 (222)	44.12 (1121)	ø12.61 (ø320)	10.26 (261)	12.30 (313)	9.53 (242)	-	576 (261)
LHYM25-4B165Y-EP	25 x 4 (18.5 x 4)	43.00 (1092)	ø15.12 (ø384)	13.39 (340)	9.06 (230)	768 (348)	49.85 (1266)	ø15.28 (ø388)	13.39 (340)	15.91 (404)	12.13 (308)	-	865 (392)
LHYM30-4B165Y-EP	30 x 4 (22 x 4)	43.00 (1092)	ø15.12 (ø384)	13.39 (340)	9.06 (230)	768 (348)	49.85 (1266)	ø15.28 (ø388)	13.39 (340)	15.91 (404)	12.13 (308)	-	865 (392)
LHYM1-4C145Y-EP	1 x 4 (0.75 x 4)	31.36 (797)	6.22 (158)	5.98 (152)	3.82 (97)	347 (158)	33.86 (860)	6.22 (158)	5.98 (152)	6.32 (161)	4.80 (122)	4.25 (108)	357 (162)
LHYM1H-4C145Y-EP	1.5 x 4 (1.1 x 4)	32.42 (824)	6.57 (167)	6.16 (156)	3.82 (97)	354 (161)	35.16 (893)	6.57 (167)	6.16 (156)	6.56 (167)	5.04 (128)	4.61 (117)	366 (166)
LHYM2-4C145Y-EP	2 x 4 (1.5 x 4)	32.42 (824)	6.57 (167)	6.16 (156)	3.82 (97)	357 (162)	35.16 (893)	6.57 (167)	6.16 (156)	6.56 (167)	5.04 (128)	4.61 (117)	369 (168)
LHYM3-4C145Y-EP	3 x 4 (2.2 x 4)	31.83 (809)	7.24 (184)	6.71 (170)	4.53 (115)	369 (168)	34.90 (887)	7.24 (184)	6.71 (170)	7.60 (193)	5.43 (138)	5.04 (128)	386 (175)
LHYM5-4C145Y-EP	5 x 4 (3.7 x 4)	33.09 (841)	8.74 (222)	7.34 (186)	4.65 (118)	393 (179)	36.66 (931)	8.74 (222)	7.34 (186)	8.21 (209)	6.02 (153)	6.30 (160)	417 (189)
LHYM8-4C145Y-EP	7.5 x 4 (5.5 x 4)	34.79 (884)	8.74 (222)	7.34 (186)	4.65 (118)	427 (194)	38.35 (974)	8.74 (222)	7.34 (186)	8.21 (209)	6.02 (153)	6.30 (160)	451 (205)
LHYM10-4C145Y-EP	10 x 4 (7.5 x 4)	36.28 (922)	10.24 (260)	9.04 (230)	5.43 (138)	454 (206)	40.42 (1027)	10.24 (260)	9.04 (230)	9.57 (243)	7.44 (189)	7.32 (186)	498 (226)
LHYM15-4C145Y-EP	15 x 4 (11 x 4)	38.72 (984)	10.24 (260)	9.04 (230)	5.43 (138)	467 (212)	42.86 (1089)	10.24 (260)	9.04 (230)	9.57 (243)	7.44 (189)	7.32 (186)	511 (232)
LHYM20-4C145Y-EP	20 x 4 (15 x 4)	41.16 (1046)	ø12.49 (ø317)	10.26 (261)	7.01 (178)	547 (248)	46.46 (1180)	ø12.61 (ø320)	10.26 (261)	12.30 (313)	9.53 (242)	-	633 (287)
LHYM1H-4C165Y-EP	1.5 x 4 (1.1 x 4)	33.26 (845)	6.57 (167)	6.16 (156)	3.82 (97)	399 (181)	36.00 (914)	6.57 (167)	6.16 (156)	6.56 (167)	5.04 (128)	4.61 (117)	411 (187)
LHYM2-4C165Y-EP	2 x 4 (1.5 x 4)	33.26 (845)	6.57 (167)	6.16 (156)	3.82 (97)	402 (183)	36.00 (914)	6.57 (167)	6.16 (156)	6.56 (167)	5.04 (128)	4.61 (117)	414 (188)
LHYM3-4C165Y-EP	3 x 4 (2.2 x 4)	32.67 (830)	7.24 (184)	6.71 (170)	4.53 (115)	412 (187)	35.74 (908)	7.24 (184)	6.71 (170)	7.60 (193)	5.43 (138)	5.04 (128)	429 (195)
LHYM5-4C165Y-EP	5 x 4 (3.7 x 4)	34.13 (867)	8.74 (222)	7.34 (186)	4.65 (118)	437 (198)	37.69 (957)	8.74 (222)	7.34 (186)	8.21 (209)	6.02 (153)	6.30 (160)	461 (209)
LHYM8-4C165Y-EP	7.5 x 4 (5.5 x 4)	35.82 (910)	8.74 (222)	7.34 (186)	4.65 (118)	471 (214)	39.39 (1000)	8.74 (222)	7.34 (186)	8.21 (209)	6.02 (153)	6.30 (160)	495 (225)
LHYM10-4C165Y-EP	10 x 4 (7.5 x 4)	37.28 (947)	10.24 (260)	9.04 (230)	5.43 (138)	499 (227)	41.41 (1052)	10.24 (260)	9.04 (230)	9.57 (243)	7.44 (189)	7.32 (186)	543 (247)
LHYM15-4C165Y-EP	15 x 4 (11 x 4)	39.72 (1009)	10.24 (260)	9.04 (230)	5.43 (138)	511 (232)	43.85 (1114)	10.24 (260)	9.04 (230)	9.57 (243)	7.44 (189)	7.32 (186)	555 (252)
LHYM20-4C165Y-EP	20 x 4 (15 x 4)	42.00 (1067)	ø12.49 (ø317)	10.26 (261)	7.01 (178)	595 (270)	47.30 (1201)	ø12.61 (ø320)	10.26 (261)	12.30 (313)	9.53 (242)	-	681 (309)
LHYM25-4C165Y-EP	25 x 4 (18.5 x 4)	46.18 (1173)	ø15.12 (ø384)	13.39 (340)	9.06 (230)	872 (396)	53.03 (1347)	ø15.28 (ø388)	13.39 (340)	15.91 (404)	12.13 (308)	-	969 (440)
LHYM30-4C165Y-EP	30 x 4 (22 x 4)	46.18 (1173)	ø15.12 (ø384)	13.39 (340)	9.06 (230)	872 (396)	53.03 (1347)	ø15.28 (ø388)	13.39 (340)	15.91 (404)	12.13 (308)	-	969 (440)
LHYM15-4C175Y-EP	15 x 4 (11 x 4)	39.93 (1014)	10.24 (260)	9.04 (230)	5.43 (138)	567 (257)	44.06 (1119)	10.24 (260)	9.04 (230)	9.57 (243)	7.44 (189)	7.32 (186)	611 (277)

Notes [1]: DM Dimension Symbol ø = Round Fan Cover  
DM Dimension Symbol = Square Fan Cover

LXXX-4XX0/4XX5 Frame sizes have equal dimensions, different ratings.



# Dimensions

## Single Reduction Cyclo® LHYM-4C170Y~4D185Y

Minimum Engagement		
Frame Size	TT	
	inch	(mm)
4C	10.98	(279)
4D	12.83	(326)

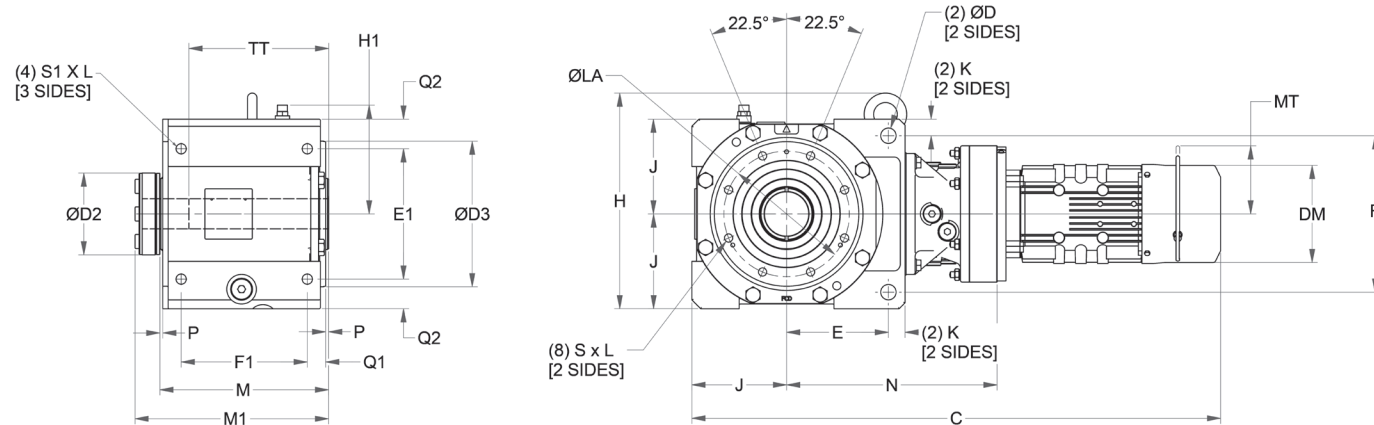
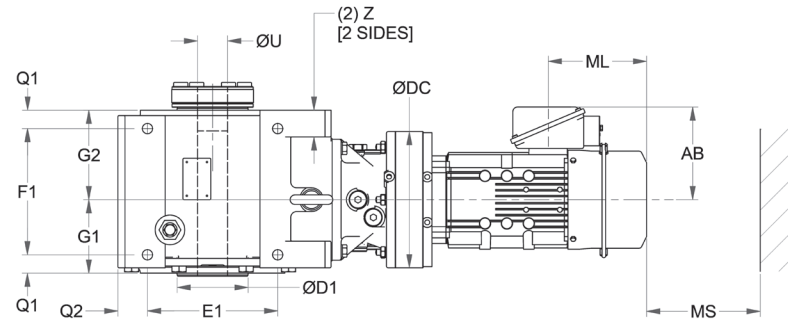

All dimensions are in inches (mm).  
For units ordered in the Y2 mounting configuration, please refer to page 2.115 for external lubricant piping dimensions.

Model	N	ØDC	J	E	F	K	Z	ØD	E1	F1	Q1	Q2	S1 x L
4C170, 4C175	15.5 (393)	13.4 (340)	6.30 (160)	6.77 (172)	10.4 (264)	1.1 (28)	1.8 (45)	1.0 (26)	8.66 (220)	8.39 (213)	1.2 (31)	2.0 (50)	M20 x 1.30 (M20 x 33)
4D170, 4D175	17.4 (443)	13.4 (340)	7.48 (190)	7.60 (193)	12.2 (310)	1.4 (35)	2.2 (55)	1.3 (33)	9.84 (250)	10.0 (254)	1.4 (36)	2.6 (65)	M24 x 1.57 (M24 x 40)
4D180, 4D185	17.6 (446)	14.6 (370)		17.6 (446)	14.6 (370)	17.6 (446)	14.6 (370)	17.6 (446)	14.6 (370)	17.6 (446)	14.6 (370)	17.6 (446)	14.6 (370)

Model	M	P	G1	G2	H	H1	ØLA	ØD3	S x L	M1	ØD1	ØD2	ØU	
													Std & Max	Min
4C170, 4C175	11.2 (285)	0.2 (5)	4.88 (124)	5.94 (151)	14.33 (364)	7.20 (183)	8.35 (212)	9.61 (244)	M16 x 1.02 (M16 x 26)	12.83 (326)	4.72 (120)	5.43 (138)	2-15/16 (74.61)	2-3/16 (55.56)
4D170, 4D175 4D180, 4D185	13.4 (340)	0.3 (7)	5.83 (148)	7.01 (178)	16.7 (424)	8.39 (213)	10.0 (255)	11.6 (295)	M20 x 1.30 (M20 x 33)	15.0 (381)	5.51 (140)	5.98 (152)	3-7/16 (87.31)	2-7/16 (61.91)

## LHYM15-4C175Y-EP ▶ LHYM15-4D185Y-EP

All dimensions are in inches (mm)

Model	4 Pole Motor HP (kW)	Without Brake					With Brake						
		C	DM <sup>[1]</sup>	AB	ML	Weight lb (kg)	C	DM <sup>[1]</sup>	AB	ML	MS	MT	Weight lb (kg)
LHYM20-4C175Y-EP	20 x 4 (15 x 4)	42.65 (1083)	ø12.49 (ø317)	10.26 (261)	7.01 (178)	647 (294)	47.94 (1218)	ø12.61 (ø320)	10.26 (261)	12.30 (313)	9.53 (242)	-	733 (333)
LHYM25-4C175Y-EP	25 x 4 (18.5 x 4)	46.82 (1189)	ø15.12 (ø384)	13.39 (340)	9.06 (230)	927 (421)	53.67 (1363)	ø15.28 (ø388)	13.39 (340)	15.91 (404)	12.13 (308)	-	1024 (465)
LHYM30-4C175Y-EP	30 x 4 (22 x 4)	46.82 (1189)	ø15.12 (ø384)	13.39 (340)	9.06 (230)	927 (421)	53.67 (1363)	ø15.28 (ø388)	13.39 (340)	15.91 (404)	12.13 (308)	-	1024 (465)
LHYM40-4C175Y-EP	40 x 4 (30 x 4)	51.70 (1313)	ø15.12 (ø384)	13.39 (340)	9.06 (230)	1040 (472)	58.55 (1487)	ø15.28 (ø388)	13.39 (340)	15.91 (404)	12.13 (308)	-	1137 (516)
LHYM2-4D165Y-EP	2 x 4 (1.5 x 4)	35.77 (909)	6.57 (167)	6.16 (156)	3.82 (97)	487 (221)	38.51 (978)	6.57 (167)	6.16 (156)	6.56 (167)	5.04 (128)	4.61 (117)	499 (226)
LHYM3-4D165Y-EP	3 x 4 (2.2 x 4)	35.52 (902)	7.24 (184)	6.71 (170)	4.53 (115)	487 (221)	38.59 (980)	7.24 (184)	6.71 (170)	7.60 (193)	5.43 (138)	5.04 (128)	504 (229)
LHYM5-4D165Y-EP	5 x 4 (3.7 x 4)	36.38 (924)	8.74 (222)	7.34 (186)	4.65 (118)	487 (221)	39.95 (1015)	8.74 (222)	7.34 (186)	8.21 (209)	6.02 (153)	6.30 (160)	511 (232)
LHYM8-4D165Y-EP	7.5 x 4 (5.5 x 4)	38.08 (967)	8.74 (222)	7.34 (186)	4.65 (118)	487 (221)	41.64 (1058)	8.74 (222)	7.34 (186)	8.21 (209)	6.02 (153)	6.30 (160)	511 (232)
LHYM10-4D165Y-EP	10 x 4 (7.5 x 4)	38.43 (976)	10.24 (260)	9.04 (230)	5.43 (138)	490 (222)	42.56 (1081)	10.24 (260)	9.04 (230)	9.57 (243)	7.44 (189)	7.32 (186)	534 (243)
LHYM15-4D165Y-EP	15 x 4 (11 x 4)	40.87 (1038)	10.24 (260)	9.04 (230)	5.43 (138)	490 (222)	45.01 (1143)	10.24 (260)	9.04 (230)	9.57 (243)	7.44 (189)	7.32 (186)	534 (242)
LHYM20-4D165Y-EP	20 x 4 (15 x 4)	42.49 (1079)	ø12.49 (ø317)	10.26 (261)	7.01 (178)	490 (222)	47.78 (1214)	ø12.61 (ø320)	10.26 (261)	12.30 (313)	9.53 (242)	-	576 (261)
LHYM25-4D165Y-EP	25 x 4 (18.5 x 4)	45.28 (1150)	ø15.12 (ø384)	13.39 (340)	9.06 (230)	506 (230)	52.13 (1324)	ø15.28 (ø388)	13.39 (340)	15.91 (404)	12.13 (308)	-	603 (274)
LHYM30-4D165Y-EP	30 x 4 (22 x 4)	45.28 (1150)	ø15.12 (ø384)	13.39 (340)	9.06 (230)	506 (230)	52.13 (1324)	ø15.28 (ø388)	13.39 (340)	15.91 (404)	12.13 (308)	-	603 (274)
LHYM5-4D175Y-EP	5 x 4 (3.7 x 4)	36.14 (918)	8.74 (222)	7.34 (186)	4.65 (118)	524 (238)	39.70 (1008)	8.74 (222)	7.34 (186)	8.21 (209)	6.02 (153)	6.30 (160)	547 (249)
LHYM8-4D175Y-EP	7.5 x 4 (5.5 x 4)	37.83 (961)	8.74 (222)	7.34 (186)	4.65 (118)	524 (238)	41.39 (1051)	8.74 (222)	7.34 (186)	8.21 (209)	6.02 (153)	6.30 (160)	547 (249)
LHYM10-4D175Y-EP	10 x 4 (7.5 x 4)	38.18 (970)	10.24 (260)	9.04 (230)	5.43 (138)	526 (239)	42.32 (1075)	10.24 (260)	9.04 (230)	9.57 (243)	7.44 (189)	7.32 (186)	571 (259)
LHYM15-4D175Y-EP	15 x 4 (11 x 4)	40.62 (1032)	10.24 (260)	9.04 (230)	5.43 (138)	526 (239)	44.76 (1137)	10.24 (260)	9.04 (230)	9.57 (243)	7.44 (189)	7.32 (186)	570 (259)
LHYM20-4D175Y-EP	20 x 4 (15 x 4)	42.24 (1073)	ø12.49 (ø317)	10.26 (261)	7.01 (178)	526 (239)	47.53 (1207)	ø12.61 (ø320)	10.26 (261)	12.30 (313)	9.53 (242)	-	612 (278)
LHYM25-4D175Y-EP	25 x 4 (18.5 x 4)	45.03 (1144)	ø15.12 (ø384)	13.39 (340)	9.06 (230)	542 (246)	51.88 (1318)	ø15.28 (ø388)	13.39 (340)	15.91 (404)	12.13 (308)	-	639 (290)
LHYM30-4D175Y-EP	30 x 4 (22 x 4)	45.03 (1144)	ø15.12 (ø384)	13.39 (340)	9.06 (230)	542 (246)	51.88 (1318)	ø15.28 (ø388)	13.39 (340)	15.91 (404)	12.13 (308)	-	639 (290)
LHYM40-4D175Y-EP	40 x 4 (30 x 4)	49.92 (1268)	ø15.12 (ø384)	13.39 (340)	9.06 (230)	542 (246)	56.77 (1442)	ø15.28 (ø388)	13.39 (340)	15.91 (404)	12.13 (308)	-	639 (290)
LHYM5-4D185Y-EP	5 x 4 (3.7 x 4)	36.26 (921)	8.74 (222)	7.34 (186)	4.65 (118)	537 (244)	39.82 (1012)	8.74 (222)	7.34 (186)	8.21 (209)	6.02 (153)	6.30 (160)	561 (255)
LHYM8-4D185Y-EP	7.5 x 4 (5.5 x 4)	37.95 (964)	8.74 (222)	7.34 (186)	4.65 (118)	537 (244)	41.52 (1055)	8.74 (222)	7.34 (186)	8.21 (209)	6.02 (153)	6.30 (160)	561 (255)
LHYM10-4D185Y-EP	10 x 4 (7.5 x 4)	38.31 (973)	10.24 (260)	9.04 (230)	5.43 (138)	540 (245)	42.44 (1078)	10.24 (260)	9.04 (230)	9.57 (243)	7.44 (189)	7.32 (186)	584 (265)
LHYM15-4D185Y-EP	15 x 4 (11 x 4)	40.75 (1035)	10.24 (260)	9.04 (230)	5.43 (138)	540 (245)	44.88 (1140)	10.24 (260)	9.04 (230)	9.57 (243)	7.44 (189)	7.32 (186)	584 (265)
LHYM20-4D185Y-EP	20 x 4 (15 x 4)	42.36 (1076)	ø12.49 (ø317)	10.26 (261)	7.01 (178)	540 (245)	47.66 (1211)	ø12.61 (ø320)	10.26 (261)	12.30 (313)	9.53 (242)	-	626 (284)
LHYM25-4D185Y-EP	25 x 4 (18.5 x 4)	45.16 (1147)	ø15.12 (ø384)	13.39 (340)	9.06 (230)	556 (252)	52.01 (1321)	ø15.28 (ø388)	13.39 (340)	15.91 (404)	12.13 (308)	-	653 (296)

Notes [1]: DM Dimension Symbol ø = Round Fan Cover  
DM Dimension Symbol = Square Fan Cover

LXXX-4XX0/4XX5 Frame sizes have equal dimensions, different ratings.

# Dimensions

## Single Reduction Cyclo® LHYM-4D180Y~4E195Y

Minimum Engagement		
Frame Size	TT	
	inch	(mm)
4D	12.83	(326)
4E	14.13	(359)

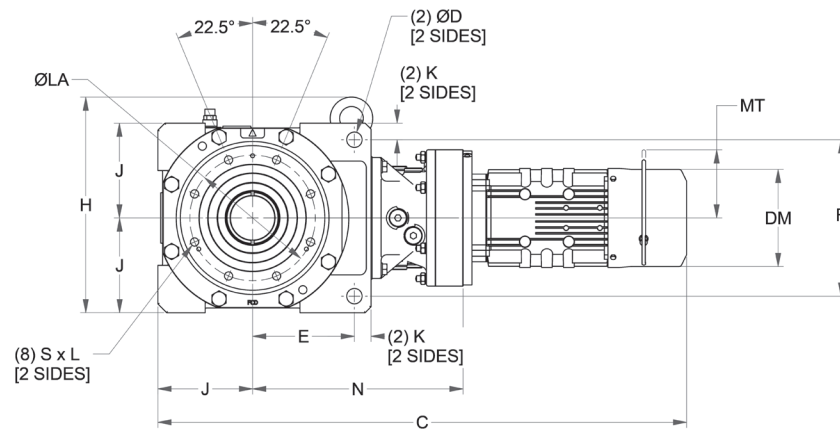
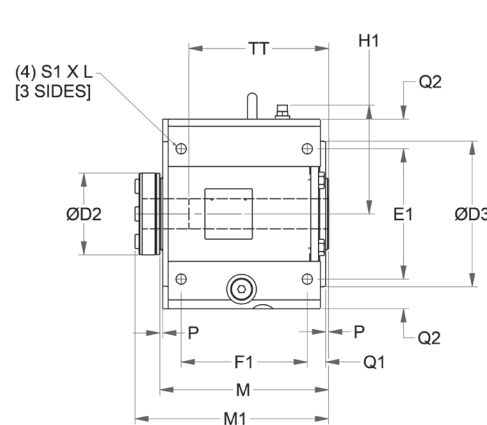
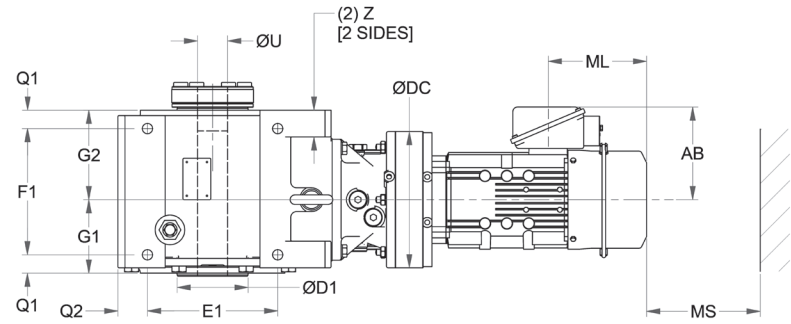

All dimensions are in inches (mm).  
For units ordered in the Y2 mounting configuration, please refer to page 2.115 for external lubricant piping dimensions.

Model	N	ØDC	J	E	F	K	Z	ØD	E1	F1	Q1	Q2	S1 x L
4D180, 4D185	17.6 (446)	14.6 (370)	7.48 (190)	7.60 (193)	12.2 (310)	1.4 (35)	2.2 (55)	1.3 (33)	9.84 (250)	10.0 (254)	1.4 (36)	2.6 (65)	M24 x 1.57 (M24 x 40)
4E170, 4E175	17.6 (446)	14.6 (370)	8.46 (215)	9.06 (230)	14.2 (360)	1.4 (35)	2.2 (55)	1.3 (33)	11.8 (300)	11.1 (283)	1.5 (38)	2.6 (65)	M24 x 1.57 (M24 x 40)
4E180, 4E185	18.5 (471)	14.6 (370)											
4E190, 4E195	19.3 (490)	16.9 (430)											

Model	M	P	G1	G2	H	H1	ØLA	ØD3	S x L	M1	ØD1	ØD2	ØU	
													Std & Max	Min
4D180, 4D185	13.4 (340)	0.3 (7)	5.83 (148)	7.01 (178)	16.7 (424)	8.39 (213)	10.0 (255)	11.6 (295)	M20 x 1.30 (M20 x 33)	15.0 (381)	5.51 (140)	5.98 (152)	3-7/16 (87.31)	2-7/16 (61.91)
4E170, 4E175 4E180, 4E185 4E190, 4E195	14.7 (373)	0.3 (7)	6.14 (156)	7.99 (203)	19.6 (498)	9.37 (238)	11.0 (280)	12.6 (320)	M20 x 1.38 (M20 x 35)	16.3 (414)	6.30 (160)	6.69 (170)	3-15/16 (100)	2-15/16 (74.61)

## LHYM20-4D185Y-EP ▶ LHYM25-4E195Y-EP

All dimensions are in inches (mm)

Model	4 Pole Motor HP (kW)	Without Brake					With Brake						
		C	DM <sup>[1]</sup>	AB	ML	Weight lb (kg)	C	DM <sup>[1]</sup>	AB	ML	MS	MT	Weight lb (kg)
LHYM30-4D185Y-EP	30 x 4 (22 x 4)	45.16 (1147)	ø15.12 (ø384)	13.39 (340)	9.06 (230)	556 (252)	52.01 (1321)	ø15.28 (ø388)	13.39 (340)	15.91 (404)	12.13 (308)	-	653 (296)
LHYM40-4D185Y-EP	40 x 4 (30 x 4)	50.04 (1271)	ø15.12 (ø384)	13.39 (340)	9.06 (230)	556 (252)	56.89 (1445)	ø15.28 (ø388)	13.39 (340)	15.91 (404)	12.13 (308)	-	653 (296)
LHYM50-4D185Y-EP	50 x 4 (37 x 4)	50.04 (1271)	ø15.12 (ø384)	13.39 (340)	9.06 (230)	556 (252)	-	-	-	-	-	-	-
LHYM5-4E175Y-EP	5 x 4 (3.7 x 4)	40.07 (1018)	8.74 (222)	7.34 (186)	4.65 (118)	796 (361)	43.64 (1108)	8.74 (222)	7.34 (186)	8.21 (209)	6.02 (153)	6.30 (160)	820 (372)
LHYM8-4E175Y-EP	7.5 x 4 (5.5 x 4)	41.77 (1061)	8.74 (222)	7.34 (186)	4.65 (118)	830 (377)	45.33 (1151)	8.74 (222)	7.34 (186)	8.21 (209)	6.02 (153)	6.30 (160)	854 (387)
LHYM10-4E175Y-EP	10 x 4 (7.5 x 4)	42.59 (1082)	10.24 (260)	9.04 (230)	5.43 (138)	859 (390)	46.73 (1187)	10.24 (260)	9.04 (230)	9.57 (243)	7.44 (189)	7.32 (186)	903 (410)
LHYM15-4E175Y-EP	15 x 4 (11 x 4)	45.03 (1144)	10.24 (260)	9.04 (230)	5.43 (138)	871 (395)	49.17 (1249)	10.24 (260)	9.04 (230)	9.57 (243)	7.44 (189)	7.32 (186)	916 (416)
LHYM20-4E175Y-EP	20 x 4 (15 x 4)	47.75 (1213)	ø12.49 (ø317)	10.26 (261)	7.01 (178)	952 (432)	53.05 (1347)	ø12.61 (ø320)	10.26 (261)	12.30 (313)	9.53 (242)	-	1038 (471)
LHYM25-4E175Y-EP	25 x 4 (18.5 x 4)	51.92 (1319)	ø15.12 (ø384)	13.39 (340)	9.06 (230)	1231 (559)	58.77 (1493)	ø15.28 (ø388)	13.39 (340)	15.91 (404)	12.13 (308)	-	1328 (603)
LHYM30-4E175Y-EP	30 x 4 (22 x 4)	51.92 (1319)	ø15.12 (ø384)	13.39 (340)	9.06 (230)	1231 (559)	58.77 (1493)	ø15.28 (ø388)	13.39 (340)	15.91 (404)	12.13 (308)	-	1328 (603)
LHYM40-4E175Y-EP	40 x 4 (30 x 4)	56.81 (1443)	ø15.12 (ø384)	13.39 (340)	9.06 (230)	1344 (610)	63.66 (1617)	ø15.28 (ø388)	13.39 (340)	15.91 (404)	12.13 (308)	-	1441 (654)
LHYM5-4E185Y-EP	5 x 4 (3.7 x 4)	40.20 (1021)	8.74 (222)	7.34 (186)	4.65 (118)	839 (381)	43.76 (1112)	8.74 (222)	7.34 (186)	8.21 (209)	6.02 (153)	6.30 (160)	863 (392)
LHYM8-4E185Y-EP	7.5 x 4 (5.5 x 4)	41.89 (1064)	8.74 (222)	7.34 (186)	4.65 (118)	873 (396)	45.45 (1155)	8.74 (222)	7.34 (186)	8.21 (209)	6.02 (153)	6.30 (160)	897 (407)
LHYM10-4E185Y-EP	10 x 4 (7.5 x 4)	42.83 (1088)	10.24 (260)	9.04 (230)	5.43 (138)	903 (410)	46.97 (1193)	10.24 (260)	9.04 (230)	9.57 (243)	7.44 (189)	7.32 (186)	948 (430)
LHYM15-4E185Y-EP	15 x 4 (11 x 4)	45.28 (1150)	10.24 (260)	9.04 (230)	5.43 (138)	916 (416)	49.41 (1255)	10.24 (260)	9.04 (230)	9.57 (243)	7.44 (189)	7.32 (186)	960 (436)
LHYM20-4E185Y-EP	20 x 4 (15 x 4)	47.87 (1216)	ø12.49 (ø317)	10.26 (261)	7.01 (178)	996 (452)	53.17 (1351)	ø12.61 (ø320)	10.26 (261)	12.30 (313)	9.53 (242)	-	1082 (491)
LHYM25-4E185Y-EP	25 x 4 (18.5 x 4)	52.05 (1322)	ø15.12 (ø384)	13.39 (340)	9.06 (230)	1273 (578)	58.90 (1496)	ø15.28 (ø388)	13.39 (340)	15.91 (404)	12.13 (308)	-	1370 (622)
LHYM30-4E185Y-EP	30 x 4 (22 x 4)	52.05 (1322)	ø15.12 (ø384)	13.39 (340)	9.06 (230)	1273 (578)	58.90 (1496)	ø15.28 (ø388)	13.39 (340)	15.91 (404)	12.13 (308)	-	1370 (622)
LHYM40-4E185Y-EP	40 x 4 (30 x 4)	56.93 (1446)	ø15.12 (ø384)	13.39 (340)	9.06 (230)	1386 (629)	63.78 (1620)	ø15.28 (ø388)	13.39 (340)	15.91 (404)	12.13 (308)	-	1483 (673)
LHYM50-4E185Y-EP	50 x 4 (37 x 4)	56.93 (1446)	ø15.12 (ø384)	13.39 (340)	9.06 (230)	1454 (660)	-	-	-	-	-	-	-
LHYM10-4E195Y-EP	10 x 4 (7.5 x 4)	43.46 (1104)	10.24 (260)	9.04 (230)	5.43 (138)	974 (442)	47.60 (1209)	10.24 (260)	9.04 (230)	9.57 (243)	7.44 (189)	7.32 (186)	1018 (462)
LHYM15-4E195Y-EP	15 x 4 (11 x 4)	45.91 (1166)	10.24 (260)	9.04 (230)	5.43 (138)	986 (448)	50.04 (1271)	10.24 (260)	9.04 (230)	9.57 (243)	7.44 (189)	7.32 (186)	1031 (468)
LHYM20-4E195Y-EP	20 x 4 (15 x 4)	48.62 (1235)	ø12.49 (ø317)	10.26 (261)	7.01 (178)	1065 (483)	53.92 (1370)	ø12.61 (ø320)	10.26 (261)	12.30 (313)	9.53 (242)	-	1151 (522)
LHYM25-4E195Y-EP	25 x 4 (18.5 x 4)	52.80 (1341)	ø15.12 (ø384)	13.39 (340)	9.06 (230)	1343 (609)	59.65 (1515)	ø15.28 (ø388)	13.39 (340)	15.91 (404)	12.13 (308)	-	1440 (653)
LHYM30-4E195Y-EP	30 x 4 (22 x 4)	52.80 (1341)	ø15.12 (ø384)	13.39 (340)	9.06 (230)	1343 (609)	59.65 (1515)	ø15.28 (ø388)	13.39 (340)	15.91 (404)	12.13 (308)	-	1440 (653)
LHYM40-4E195Y-EP	40 x 4 (30 x 4)	57.68 (1465)	ø15.12 (ø384)	13.39 (340)	9.06 (230)	1456 (661)	64.53 (1639)	ø15.28 (ø388)	13.39 (340)	15.91 (404)	12.13 (308)	-	1553 (705)
LHYM50-4E195Y-EP	50 x 4 (37 x 4)	57.68 (1465)	ø15.12 (ø384)	13.39 (340)	9.06 (230)	1524 (692)	-	-	-	-	-	-	-

Notes [1]: DM Dimension Symbol ø = Round Fan Cover  
DM Dimension Symbol = Square Fan Cover

LXXX-4XX0/4XX5 Frame sizes have equal dimensions, different ratings.

# Dimensions

## LHYM30-4E195Y-EP ▶ LHYM60-4F195Y-EP

### Single Reduction Cyclo® LHYM-4E190Y~4F195Y

Minimum Engagement		
Frame Size	TT	
	inch	(mm)
4E	14.13	(359)
4F	16.22	(412)

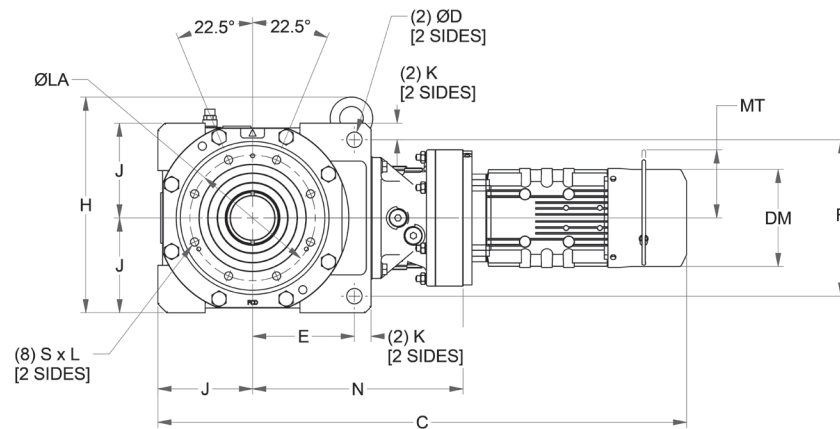
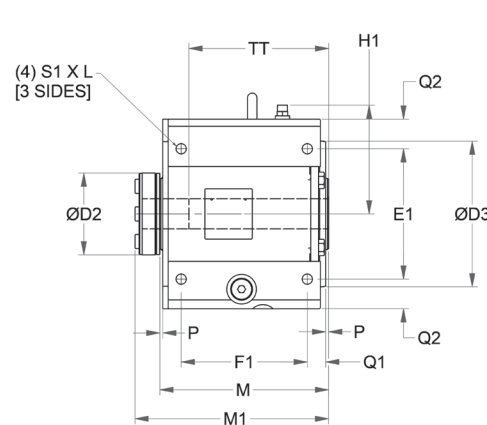
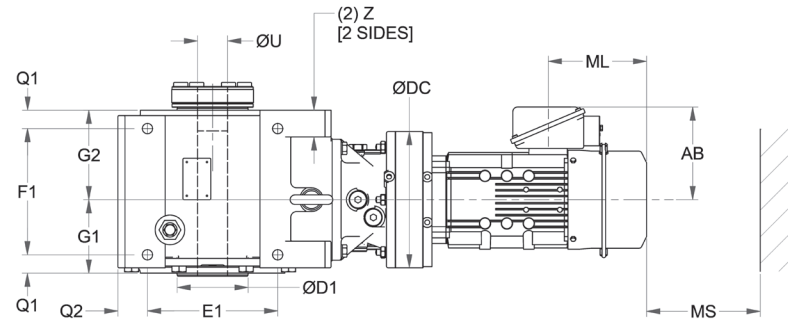

All dimensions are in inches (mm).  
For units ordered in the Y2 mounting configuration, please refer to page 2.115 for external lubricant piping dimensions.

Model	N	ØDC	J	E	F	K	Z	ØD	E1	F1	Q1	Q2	S1 x L
4E190, 4E195	19.3 (490)	16.9 (430)	8.46 (215)	9.06 (230)	14.2 (360)	1.4 (35)	2.2 (55)	1.3 (33)	11.8 (300)	11.1 (283)	1.5 (38)	2.6 (65)	M24 x 1.57 (M24 x 40)
4F180, 4F185	21.1 (535)	14.6 (370)	9.45 (240)	9.92 (252)	15.8 (400)	1.8 (45)	2.8 (70)	1.5 (39)	13.4 (340)	12.6 (320)	1.99 (50.5)	2.8 (70)	M30 x 1.97 (M30 x 50)
4F190, 4F195	21.7 (552)	16.9 (430)		13.4 (340)	12.6 (320)	1.99 (50.5)	2.8 (70)						

Model	M	P	G1	G2	H	H1	ØLA	ØD3	S x L	M1	ØD1	ØD2	ØU	
													Std & Max	Min
4E190, 4E195	14.7 (373)	0.3 (7)	6.14 (156)	7.99 (203)	19.6 (498)	9.37 (238)	11.0 (280)	12.6 (320)	M20 x 1.38 (M20 x 35)	16.3 (414)	6.30 (160)	6.69 (170)	3-15/16 (100)	2-15/16 (74.61)
4F180, 4F185 4F190, 4F195	17.1 (435)	0.3 (7)	9.37 (238)	7.20 (183)	23.2 (590)	10.8 (273)	12.6 (320)	14.6 (370)	M24 x 1.57 (M24 x 40)	19.1 (486)	7.09 (180)	7.32 (186)	4-15/16 (125.413)	3-15/16 (100.013)

All dimensions are in inches (mm)

Model	4 Pole Motor HP (kW)	Without Brake					With Brake						
		C	DM <sup>[1]</sup>	AB	ML	Weight lb (kg)	C	DM <sup>[1]</sup>	AB	ML	MS	MT	Weight lb (kg)
LHYM60-4E195Y-EP	60 x 4 (45 x 4)	59.13 (1502)	ø18.66 (ø474)	16.33 (415)	16.81 (427)	1653 (750)	-	-	-	-	-	-	-
LHYM5-4F185Y-EP	5 x 4 (3.7 x 4)	43.68 (1109)	8.74 (222)	7.34 (186)	4.65 (118)	1273 (578)	47.24 (1200)	8.74 (222)	7.34 (186)	8.21 (209)	6.02 (153)	6.30 (160)	1297 (588)
LHYM8-4F185Y-EP	7.5 x 4 (5.5 x 4)	45.37 (1152)	8.74 (222)	7.34 (186)	4.65 (118)	1307 (593)	48.93 (1243)	8.74 (222)	7.34 (186)	8.21 (209)	6.02 (153)	6.30 (160)	1331 (604)
LHYM10-4F185Y-EP	10 x 4 (7.5 x 4)	46.31 (1176)	10.24 (260)	9.04 (230)	5.43 (138)	1337 (607)	50.45 (1281)	10.24 (260)	9.04 (230)	9.57 (243)	7.44 (189)	7.32 (186)	1381 (627)
LHYM15-4F185Y-EP	15 x 4 (11 x 4)	48.75 (1238)	10.24 (260)	9.04 (230)	5.43 (138)	1350 (613)	52.89 (1343)	10.24 (260)	9.04 (230)	9.57 (243)	7.44 (189)	7.32 (186)	1394 (633)
LHYM20-4F185Y-EP	20 x 4 (15 x 4)	51.35 (1304)	ø12.49 (ø317)	10.26 (261)	7.01 (178)	1430 (649)	56.65 (1439)	ø12.61 (ø320)	10.26 (261)	12.30 (313)	9.53 (242)	-	1516 (688)
LHYM25-4F185Y-EP	25 x 4 (18.5 x 4)	55.53 (1410)	ø15.12 (ø384)	13.39 (340)	9.06 (230)	1707 (774)	62.38 (1584)	ø15.28 (ø388)	13.39 (340)	15.91 (404)	12.13 (308)	-	1804 (818)
LHYM30-4F185Y-EP	30 x 4 (22 x 4)	55.53 (1410)	ø15.12 (ø384)	13.39 (340)	9.06 (230)	1707 (774)	62.38 (1584)	ø15.28 (ø388)	13.39 (340)	15.91 (404)	12.13 (308)	-	1804 (818)
LHYM40-4F185Y-EP	40 x 4 (30 x 4)	60.41 (1534)	ø15.12 (ø384)	13.39 (340)	9.06 (230)	1820 (826)	67.26 (1708)	ø15.28 (ø388)	13.39 (340)	15.91 (404)	12.13 (308)	-	1917 (870)
LHYM50-4F185Y-EP	50 x 4 (37 x 4)	60.41 (1534)	ø15.12 (ø384)	13.39 (340)	9.06 (230)	1888 (857)	-	-	-	-	-	-	-
LHYM5-4F195Y-EP	5 x 4 (3.7 x 4)	44.96 (1142)	8.74 (222)	7.34 (186)	4.65 (118)	1337 (607)	48.52 (1233)	8.74 (222)	7.34 (186)	8.21 (209)	6.02 (153)	6.30 (160)	1360 (617)
LHYM8-4F195Y-EP	7.5 x 4 (5.5 x 4)	46.65 (1185)	8.74 (222)	7.34 (186)	4.65 (118)	1370 (622)	50.22 (1276)	8.74 (222)	7.34 (186)	8.21 (209)	6.02 (153)	6.30 (160)	1394 (633)
LHYM10-4F195Y-EP	10 x 4 (7.5 x 4)	46.89 (1191)	10.24 (260)	9.04 (230)	5.43 (138)	1401 (636)	51.02 (1296)	10.24 (260)	9.04 (230)	9.57 (243)	7.44 (189)	7.32 (186)	1445 (656)
LHYM15-4F195Y-EP	15 x 4 (11 x 4)	49.33 (1253)	10.24 (260)	9.04 (230)	5.43 (138)	1414 (641)	53.46 (1358)	10.24 (260)	9.04 (230)	9.57 (243)	7.44 (189)	7.32 (186)	1458 (662)
LHYM20-4F195Y-EP	20 x 4 (15 x 4)	52.05 (1322)	ø12.49 (ø317)	10.26 (261)	7.01 (178)	1492 (677)	57.34 (1457)	ø12.61 (ø320)	10.26 (261)	12.30 (313)	9.53 (242)	-	1578 (716)
LHYM25-4F195Y-EP	25 x 4 (18.5 x 4)	56.22 (1428)	ø15.12 (ø384)	13.39 (340)	9.06 (230)	1770 (803)	63.07 (1602)	ø15.28 (ø388)	13.39 (340)	15.91 (404)	12.13 (308)	-	1867 (847)
LHYM30-4F195Y-EP	30 x 4 (22 x 4)	56.22 (1428)	ø15.12 (ø384)	13.39 (340)	9.06 (230)	1770 (803)	63.07 (1602)	ø15.28 (ø388)	13.39 (340)	15.91 (404)	12.13 (308)	-	1867 (847)
LHYM40-4F195Y-EP	40 x 4 (30 x 4)	61.10 (1552)	ø15.12 (ø384)	13.39 (340)	9.06 (230)	1883 (855)	67.95 (1726)	ø15.28 (ø388)	13.39 (340)	15.91 (404)	12.13 (308)	-	1980 (899)
LHYM50-4F195Y-EP	50 x 4 (37 x 4)	61.10 (1552)	ø15.12 (ø384)	13.39 (340)	9.06 (230)	1952 (886)	-	-	-	-	-	-	-
LHYM60-4F195Y-EP	60 x 4 (45 x 4)	62.56 (1589)	ø18.66 (ø474)	16.33 (415)	16.81 (427)	2080 (944)	-	-	-	-	-	-	-

Notes [1]: DM Dimension Symbol ø = Round Fan Cover  
DM Dimension Symbol = Square Fan Cover

LXXX-4XX0/4XX5 Frame sizes have equal dimensions, different ratings.

# Dimensions

# Dimensions

## Single Reduction Cyclo®, Y2 Mounting External Lubricant Piping LHY(J)-4A100 ~ 4F195

Page intentionally left blank.

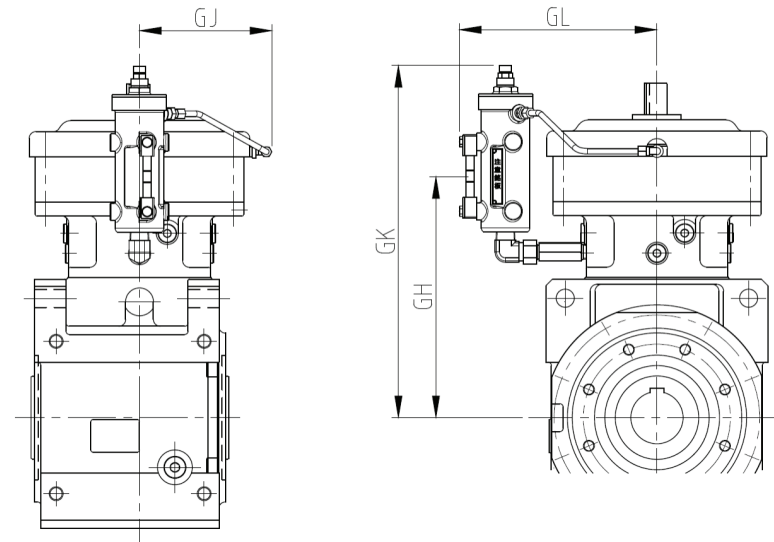

All dimensions are in inches (mm).

Frame Size	GJ	GL	GH	GK
4A100	3.86	8.43	8.82	14.5
4A105	(98)	(214)	(224)	(369)
4A110	4.02	8.5	8.98	14.5
4A115	(102)	(216)	(228)	(369)
4A120	6.38	10.1	8.94	14.6
4A125	(162)	(256)	(227)	(371)
4A140	6.46	10.8	9.61	16.1
4A145	(164)	(275)	(244)	(408)
4B120	6.38	10.1	10.4	16.1
4B125	(162)	(256)	(263)	(408)
4B140	6.46	10.8	10.9	17.3
4B145	(164)	(275)	(277)	(440)
4B160	7.09	11.2	11.7	18.0
4B165	(180)	(285)	(297)	(457)
4C140	6.46	10.8	13.2	19.6
4C145	(164)	(275)	(335)	(498)
4C160	7.09	11.2	13.7	20.0
4C165	(180)	(285)	(348)	(508)
4C170	7.95	12.2	14.1	22.4
4C175	(202)	(311)	(359)	(568)
4D160	7.09	11.2	16.5	22.8
4D165	(180)	(285)	(420)	(580)
4D170	7.95	12.2	16.1	24.3
4D175	(202)	(311)	(408)	(618)
4D180	9.06	13.0	16.3	26.9
4D185	(230)	(331)	(414)	(684)
4E170	7.95	12.2	17.0	25.3
4E175	(202)	(311)	(433)	(643)
4E180	9.06	13.0	17.3	27.9
4E185	(230)	(331)	(439)	(709)
4E190	10.2	15.0	17.7	28.3
4E195	(260)	(381)	(449)	(719)
4F180	9.06	13.0	19.8	30.4
4F185	(230)	(331)	(503)	(772)
4F190	10.2	15.0	20.1	30.7
4F195	(260)	(381)	(511)	(781)

Cyclo® BBB4

Cyclo® BBB4

Dimensions

Dimensions



# Dimensions

## LHYM01-4A10DAY ▶ LHYM05-4B12DAY

### Double Reduction Cyclo® LHYM-4A10DAY~4B12DAY

Minimum Engagement		
Frame Size	TT	
	inch	(mm)
4A	8.19	(300)
4B	9.53	(242)

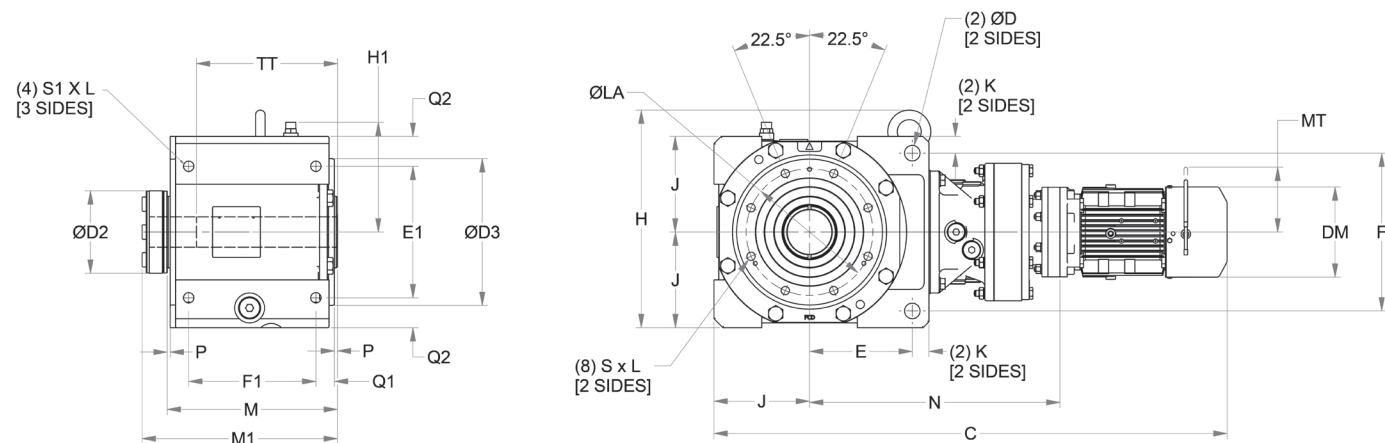
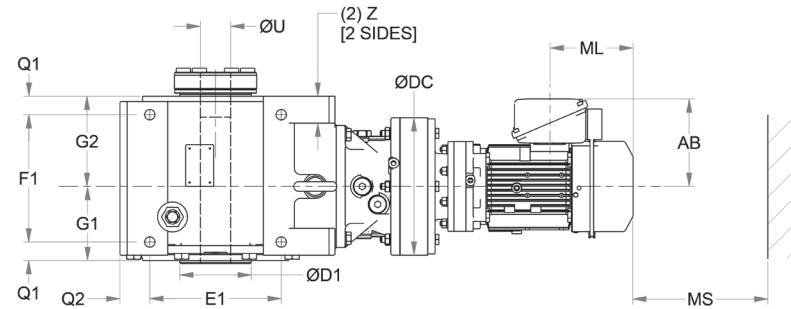

All dimensions are in inches (mm).  
For double reduction units ordered in the Y2 mounting configuration, please refer to page 2.133 for external lubricant piping dimensions.

Model	N	ØDC	J	E	F	K	Z	ØD	E1	F1	Q1	Q2	S1 x L	M
4A10DA	11.2 (285)	5.91 (150)	4.33 (110)	4.49 (114)	7.24 (184)	0.71 (18)	1.38 (35)	0.71 (18)	5.91 (150)	6.30 (160)	0.91 (23)	1.38 (23)	M12 x 0.79 (M12 x 20)	8.50 (216)
4A12DA	11.7 (297)	8.03 (204)												
4A12DB	12.2 (309)	8.03 (204)												
4B12DA	13.2 (334)	8.03 (204)	5.12 (120)	5.59 (142)	8.43 (214)	0.91 (23)	1.58 (40)	0.87 (22)	7.48 (190)	7.68 (195)	1.06 (27)	1.38 (35)	M16 x 1.02 (M16 x 26)	10.20 (259)

Model	P	G1	G2	H	H1	ØLA	ØD3	S x L	M1	ØD1	ØD2	ØU	
												Std & Max	Min
4A10DB, 4A12DA, 4A12DB	0.20 (5)	3.78 (96)	4.33 (110)	10.87 (276)	5.16 (131)	6.10 (155)	6.89 (175)	M10 x 0.67 (M10 x 17)	9.84 (250)	3.35 (85)	4.09 (104)	2-3/16 (55.56)	1-11/16 (42.86)
4B12DA	0.20 (5)	4.80 (122)	5.00 (127)	12.1 (308)	5.94 (151)	6.89 (175)	7.83 (199)	M12 x 0.79 (M12 x 20)	11.5 (293)	3.94 (100)	4.49 (114)	2-7/16 (61.91)	1-15/16 (49.21)

All dimensions are in inches (mm)

Model	4 Pole Motor HP (kW)	Without Brake					With Brake						
		C	DM <sup>[1]</sup>	AB	ML	Weight lb (kg)	C	DM <sup>[1]</sup>	AB	ML	MS	MT	Weight lb (kg)
LHYM01-4A10DAY	1/8 x 4 (0.1 x 4)	20.84 (529)	ø4.69 (ø119)	4.63 (118)	1.38 (35)	120 (55)	22.22 (564)	ø4.88 (ø124)	4.63 (118)	2.76 (70)	1.93 (49)	-	124 (56)
LHYM01-4A10DAY-AV	1/8 x 4 (0.1 x 4)	22.49 (571)	ø4.88 (ø124)	4.63 (118)	2.32 (59)	123 (56)	23.75 (603)	ø4.88 (ø124)	4.63 (118)	3.58 (91)	2.40 (61)	-	126 (57)
LHYM02-4A10DAY	1/4 x 4 (0.2 x 4)	22.49 (571)	ø4.88 (ø124)	4.63 (118)	2.32 (59)	123 (56)	23.75 (603)	ø4.88 (ø124)	4.63 (118)	3.58 (91)	2.40 (61)	-	126 (57)
LHYM02-4A10DAY-AV	1/4 x 4 (0.2 x 4)	23.28 (591)	ø4.88 (ø124)	4.63 (118)	2.32 (59)	126 (57)	24.54 (623)	ø4.88 (ø124)	4.63 (118)	3.58 (91)	2.40 (61)	-	129 (59)
LHYM03-4A10DAY	1/3 x 4 (0.25 x 4)	22.49 (571)	ø4.88 (ø124)	4.63 (118)	2.32 (59)	123 (56)	23.75 (603)	ø4.88 (ø124)	4.63 (118)	3.58 (91)	2.40 (61)	-	126 (57)
LHYM03-4A10DAY-AV	1/3 x 4 (0.25 x 4)	23.28 (591)	ø4.88 (ø124)	4.63 (118)	2.32 (59)	126 (57)	24.54 (623)	ø4.88 (ø124)	4.63 (118)	3.58 (91)	2.40 (61)	-	129 (59)
LHYM05-4A10DAY	1/2 x 4 (0.4 x 4)	23.28 (591)	ø4.88 (ø124)	4.63 (118)	2.32 (59)	126 (57)	24.54 (623)	ø4.88 (ø124)	4.63 (118)	3.58 (91)	2.40 (61)	-	129 (59)
LHYM01-4A12DAY	1/8 x 4 (0.1 x 4)	21.30 (541)	ø4.69 (ø119)	4.63 (118)	1.38 (35)	138 (63)	22.68 (576)	ø4.88 (ø124)	4.63 (118)	2.76 (70)	1.93 (49)	-	141 (64)
LHYM01-4A12DAY-AV	1/8 x 4 (0.1 x 4)	22.96 (583)	ø4.88 (ø124)	4.63 (118)	2.32 (59)	140 (64)	24.22 (615)	ø4.88 (ø124)	4.63 (118)	3.58 (91)	2.40 (61)	-	143 (65)
LHYM01-4A12DBY	1/8 x 4 (0.1 x 4)	21.76 (553)	ø4.69 (ø119)	4.63 (118)	1.38 (35)	143 (65)	23.13 (588)	ø4.88 (ø124)	4.63 (118)	2.76 (70)	1.93 (49)	-	146 (67)
LHYM01-4A12DBY-AV	1/8 x 4 (0.1 x 4)	23.41 (595)	ø4.88 (ø124)	4.63 (118)	2.32 (59)	145 (66)	24.67 (627)	ø4.88 (ø124)	4.63 (118)	3.58 (91)	2.40 (61)	-	148 (67)
LHYM02-4A12DBY	1/4 x 4 (0.2 x 4)	23.41 (595)	ø4.88 (ø124)	4.63 (118)	2.32 (59)	145 (66)	24.67 (627)	ø4.88 (ø124)	4.63 (118)	3.58 (91)	2.40 (61)	-	148 (67)
LHYM02-4A12DBY-AV	1/4 x 4 (0.2 x 4)	24.20 (615)	ø4.88 (ø124)	4.63 (118)	2.32 (59)	148 (67)	25.46 (647)	ø4.88 (ø124)	4.63 (118)	3.58 (91)	2.40 (61)	-	151 (69)
LHYM03-4A12DBY	1/3 x 4 (0.25 x 4)	23.41 (595)	ø4.88 (ø124)	4.63 (118)	2.32 (59)	145 (66)	24.67 (627)	ø4.88 (ø124)	4.63 (118)	3.58 (91)	2.40 (61)	-	148 (67)
LHYM03-4A12DBY-AV	1/3 x 4 (0.25 x 4)	24.20 (615)	ø4.88 (ø124)	4.63 (118)	2.32 (59)	148 (67)	25.46 (647)	ø4.88 (ø124)	4.63 (118)	3.58 (91)	2.40 (61)	-	151 (69)
LHYM05-4A12DBY	1/2 x 4 (0.4 x 4)	24.20 (615)	ø4.88 (ø124)	4.63 (118)	2.32 (59)	148 (67)	25.46 (647)	ø4.88 (ø124)	4.63 (118)	3.58 (91)	2.40 (61)	-	151 (69)
LHYM05-4A12DBY-AV	1/2 x 4 (0.4 x 4)	25.81 (656)	ø5.94 (ø151)	5.67 (144)	3.82 (97)	155 (71)	27.50 (699)	ø5.94 (ø151)	5.67 (144)	5.51 (140)	3.66 (93)	3.94 (100)	161 (73)
LHYM08-4A12DBY	3/4 x 4 (0.55 x 4)	25.81 (656)	ø5.94 (ø151)	5.67 (144)	3.82 (97)	153 (70)	27.50 (699)	ø5.94 (ø151)	5.67 (144)	5.51 (140)	3.66 (93)	3.94 (100)	159 (72)
LHYM08-4A12DBY-AV	3/4 x 4 (0.55 x 4)	27.11 (689)	ø6.30 (ø160)	5.86 (149)	3.94 (100)	164 (75)	29.55 (751)	ø6.30 (ø160)	5.86 (149)	6.38 (162)	4.53 (115)	4.29 (109)	174 (79)
LHYM01-4B12DAY	1/8 x 4 (0.1 x 4)	23.54 (598)	ø4.69 (ø119)	4.63 (118)	1.38 (35)	203 (92)	24.91 (633)	ø4.88 (ø124)	4.63 (118)	2.76 (70)	1.93 (49)	-	206 (94)
LHYM01-4B12DAY-AV	1/8 x 4 (0.1 x 4)	25.19 (640)	ø4.88 (ø124)	4.63 (118)	2.32 (59)	205 (93)	26.45 (672)	ø4.88 (ø124)	4.63 (118)	3.58 (91)	2.40 (61)	-	208 (95)
LHYM02-4B12DAY	1/4 x 4 (0.2 x 4)	25.19 (640)	ø4.88 (ø124)	4.63 (118)	2.32 (59)	205 (93)	26.45 (672)	ø4.88 (ø124)	4.63 (118)	3.58 (91)	2.40 (61)	-	208 (95)
LHYM02-4B12DAY-AV	1/4 x 4 (0.2 x 4)	25.98 (660)	ø4.88 (ø124)	4.63 (118)	2.32 (59)	208 (95)	27.24 (692)	ø4.88 (ø124)	4.63 (118)	3.58 (91)	2.40 (61)	-	211 (96)
LHYM03-4B12DAY	1/3 x 4 (0.25 x 4)	25.19 (640)	ø4.88 (ø124)	4.63 (118)	2.32 (59)	205 (93)	26.45 (672)	ø4.88 (ø124)	4.63 (118)	3.58 (91)	2.40 (61)	-	208 (95)
LHYM03-4B12DAY-AV	1/3 x 4 (0.25 x 4)	25.98 (660)	ø4.88 (ø124)	4.63 (118)	2.32 (59)	208 (95)	27.24 (692)	ø4.88 (ø124)	4.63 (118)	3.58 (91)	2.40 (61)	-	211 (96)
LHYM05-4B12DAY	1/2 x 4 (0.4 x 4)	25.98 (660)	ø4.88 (ø124)	4.63 (118)	2.32 (59)	208 (95)	27.24 (692)	ø4.88 (ø124)	4.63 (118)	3.58 (91)	2.40 (61)	-	211 (96)
LHYM02-4B12DBY	1/4 x 4 (0.2 x 4)	25.64 (651)	ø4.88 (ø124)	4.63 (118)	2.32 (59)	210 (95)	26.90 (683)	ø4.88 (ø124)	4.63 (118)	3.58 (91)	2.40 (61)	-	213 (97)

Notes [1]: DM Dimension Symbol ø = Round Fan Cover  
DM Dimension Symbol = Square Fan Cover

LXXX-4XX0/4XX5 Frame sizes have equal dimensions, different ratings.

# Dimensions

## LHYM02-4B12DBY ▶ LHYM01-4C14DAY-AV

### Double Reduction Cyclo® LHYM-4B12DBY~4C14DAY

Minimum Engagement		
Frame Size	TT	
	inch	(mm)
4B	9.53	(242)
4C	10.98	(279)

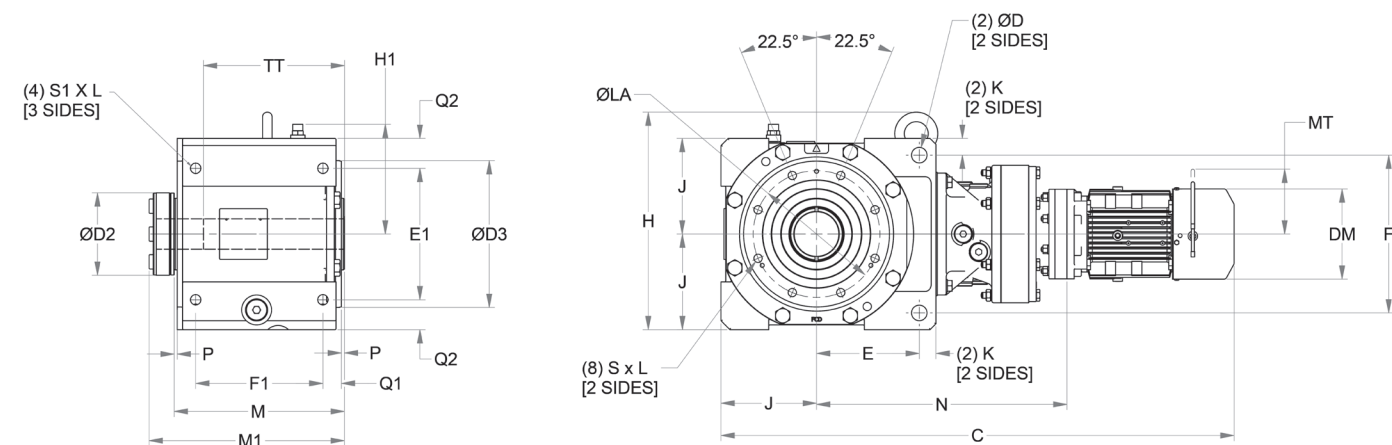
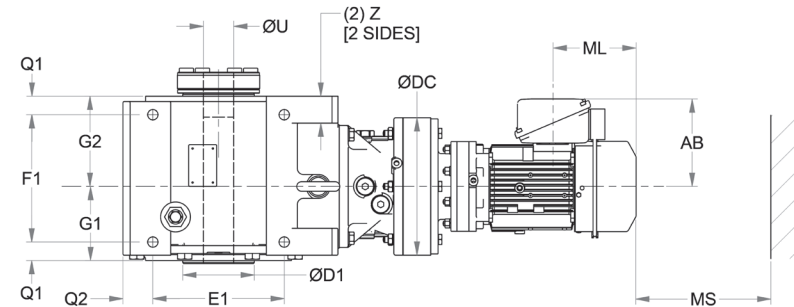

All dimensions are in inches (mm).  
For double reduction units ordered in the Y2 mounting configuration, please refer to page 2.133 for external lubricant piping dimensions.

Model	N	ØDC	J	E	F	K	Z	ØD	E1	F1	Q1	Q2	S1 x L	M
4B12DB	13.6 (346)	8.03 (204)	5.12 (130)	5.59 (142)	8.43 (214)	0.91 (23)	1.58 (40)	0.87 (22)	7.48 (190)	7.68 (195)	1.06 (27)	1.38 (35)	M16 x 1.02 (M16 x 26)	10.20 (259)
4B14DB	14.2 (360)	9.06 (230)												
4C14DA	16.1 (410)	9.06 (230)	6.30 (160)	6.77 (172)	10.4 (264)	1.10 (28)	1.77 (45)	1.02 (26)	8.66 (220)	8.39 (213)	1.22 (31)	1.97 (50)	M20 x 1.30 (M20 x 30)	11.2 (285)

Model	P	G1	G2	H	H1	ØLA	ØD3	S x L	M1	ØD1	ØD2	ØU	
												Std & Max	Min
4B12DB, 4B14DB	0.20 (5)	4.80 (122)	5.00 (127)	12.1 (308)	5.94 (151)	6.89 (175)	7.83 (199)	M12 x 0.79 (M12 x 20)	11.5 (293)	3.94 (100)	4.49 (114)	2-7/16 (61.91)	1-15/16 (49.21)
4C14DA	0.20 (5)	4.88 (124)	5.94 (151)	14.3 (364)	7.20 (183)	8.35 (212)	9.61 (244)	M16 x 1.02 (M16 x 26)	12.8 (326)	4.72 (120)	5.43 (138)	2-15/16 (74.61)	2-3/16 (55.56)

All dimensions are in inches (mm)

Model	4 Pole Motor HP (kW)	Without Brake					With Brake						
		C	DM <sup>[1]</sup>	AB	ML	Weight lb (kg)	C	DM <sup>[1]</sup>	AB	ML	MS	MT	Weight lb (kg)
LHYM02-4B12DBY-AV	1/4 x 4 (0.2 x 4)	26.43 (671)	ø4.88 (ø124)	4.63 (118)	2.32 (59)	213 (97)	27.69 (703)	ø4.88 (ø124)	4.63 (118)	3.58 (91)	2.40 (61)	-	216 (98)
LHYM03-4B12DBY	1/3 x 4 (0.25 x 4)	25.64 (651)	ø4.88 (ø124)	4.63 (118)	2.32 (59)	210 (95)	26.90 (683)	ø4.88 (ø124)	4.63 (118)	3.58 (91)	2.40 (61)	-	213 (97)
LHYM03-4B12DBY-AV	1/3 x 4 (0.25 x 4)	26.43 (671)	ø4.88 (ø124)	4.63 (118)	2.32 (59)	213 (97)	27.69 (703)	ø4.88 (ø124)	4.63 (118)	3.58 (91)	2.40 (61)	-	216 (98)
LHYM05-4B12DBY	1/2 x 4 (0.4 x 4)	26.43 (671)	ø4.88 (ø124)	4.63 (118)	2.32 (59)	213 (97)	27.69 (703)	ø4.88 (ø124)	4.63 (118)	3.58 (91)	2.40 (61)	-	216 (98)
LHYM05-4B12DBY-AV	1/2 x 4 (0.4 x 4)	28.04 (712)	ø5.94 (ø151)	5.67 (144)	3.82 (97)	220 (100)	29.74 (755)	ø5.94 (ø151)	5.67 (144)	5.51 (140)	3.66 (93)	3.94 (100)	226 (103)
LHYM08-4B12DBY	3/4 x 4 (0.55 x 4)	28.04 (712)	ø5.94 (ø151)	5.67 (144)	3.82 (97)	217 (99)	29.74 (755)	ø5.94 (ø151)	5.67 (144)	5.51 (140)	3.66 (93)	3.94 (100)	223 (102)
LHYM08-4B12DBY-AV	3/4 x 4 (0.55 x 4)	29.34 (745)	ø6.30 (ø160)	5.86 (149)	3.94 (100)	228 (104)	31.78 (807)	ø6.30 (ø160)	5.86 (149)	6.38 (162)	4.53 (115)	4.29 (109)	239 (109)
LHYM1-4B12DBY-EP	1 x 4 (0.75 x 4)	29.78 (756)	6.22 (158)	5.98 (152)	3.82 (97)	233 (106)	32.28 (820)	6.22 (158)	5.98 (152)	6.32 (161)	4.80 (122)	4.25 (108)	243 (110)
LHYM1H-4B12DBY-EP	1.5 x 4 (1.1 x 4)	30.84 (783)	6.57 (167)	6.16 (156)	3.82 (97)	241 (109)	33.57 (853)	6.57 (167)	6.16 (156)	6.56 (167)	5.04 (128)	4.61 (117)	252 (115)
LHYM01-4B14DAY	1/8 x 4 (0.1 x 4)	24.25 (616)	ø4.69 (ø119)	4.63 (118)	1.38 (35)	209 (95)	25.62 (651)	ø4.88 (ø124)	4.63 (118)	2.76 (70)	1.93 (49)	-	213 (97)
LHYM01-4B14DAY-AV	1/8 x 4 (0.1 x 4)	25.90 (658)	ø4.88 (ø124)	4.63 (118)	2.32 (59)	211 (96)	27.16 (690)	ø4.88 (ø124)	4.63 (118)	3.58 (91)	2.40 (61)	-	214 (98)
LHYM02-4B14DAY	1/4 x 4 (0.2 x 4)	25.90 (658)	ø4.88 (ø124)	4.63 (118)	2.32 (59)	211 (96)	27.16 (690)	ø4.88 (ø124)	4.63 (118)	3.58 (91)	2.40 (61)	-	214 (98)
LHYM02-4B14DAY-AV	1/4 x 4 (0.2 x 4)	26.69 (678)	ø4.88 (ø124)	4.63 (118)	2.32 (59)	214 (98)	27.95 (710)	ø4.88 (ø124)	4.63 (118)	3.58 (91)	2.40 (61)	-	218 (99)
LHYM02-4B14DBY	1/4 x 4 (0.2 x 4)	26.25 (667)	ø4.88 (ø124)	4.63 (118)	2.32 (59)	219 (99)	27.51 (699)	ø4.88 (ø124)	4.63 (118)	3.58 (91)	2.40 (61)	-	222 (101)
LHYM02-4B14DBY-AV	1/4 x 4 (0.2 x 4)	27.04 (687)	ø4.88 (ø124)	4.63 (118)	2.32 (59)	222 (101)	28.30 (719)	ø4.88 (ø124)	4.63 (118)	3.58 (91)	2.40 (61)	-	225 (102)
LHYM03-4B14DBY	1/3 x 4 (0.25 x 4)	26.25 (667)	ø4.88 (ø124)	4.63 (118)	2.32 (59)	219 (99)	27.51 (699)	ø4.88 (ø124)	4.63 (118)	3.58 (91)	2.40 (61)	-	222 (101)
LHYM03-4B14DBY-AV	1/3 x 4 (0.25 x 4)	27.04 (687)	ø4.88 (ø124)	4.63 (118)	2.32 (59)	222 (101)	28.30 (719)	ø4.88 (ø124)	4.63 (118)	3.58 (91)	2.40 (61)	-	225 (102)
LHYM05-4B14DBY	1/2 x 4 (0.4 x 4)	27.04 (687)	ø4.88 (ø124)	4.63 (118)	2.32 (59)	222 (101)	28.30 (719)	ø4.88 (ø124)	4.63 (118)	3.58 (91)	2.40 (61)	-	225 (102)
LHYM05-4B14DBY-AV	1/2 x 4 (0.4 x 4)	28.66 (728)	ø5.94 (ø151)	5.67 (144)	3.82 (97)	229 (104)	30.35 (771)	ø5.94 (ø151)	5.67 (144)	5.51 (140)	3.66 (93)	3.94 (100)	235 (107)
LHYM08-4B14DBY	3/4 x 4 (0.55 x 4)	28.66 (728)	ø5.94 (ø151)	5.67 (144)	3.82 (97)	226 (103)	30.35 (771)	ø5.94 (ø151)	5.67 (144)	5.51 (140)	3.66 (93)	3.94 (100)	232 (106)
LHYM08-4B14DBY-AV	3/4 x 4 (0.55 x 4)	29.95 (761)	ø6.30 (ø160)	5.86 (149)	3.94 (100)	237 (108)	32.40 (823)	ø6.30 (ø160)	5.86 (149)	6.38 (162)	4.53 (115)	4.29 (109)	248 (113)
LHYM1-4B14DBY-EP	1 x 4 (0.75 x 4)	30.39 (772)	6.22 (158)	5.98 (152)	3.82 (97)	242 (110)	32.89 (835)	6.22 (158)	5.98 (152)	6.32 (161)	4.80 (122)	4.25 (108)	252 (114)
LHYM1H-4B14DBY-EP	1.5 x 4 (1.1 x 4)	31.45 (799)	6.57 (167)	6.16 (156)	3.82 (97)	249 (113)	34.19 (868)	6.57 (167)	6.16 (156)	6.56 (167)	5.04 (128)	4.61 (117)	261 (119)
LHYM01-4C14DAY	1/8 x 4 (0.1 x 4)	27.72 (704)	ø4.69 (ø119)	4.63 (118)	1.38 (35)	316 (144)	29.10 (739)	ø4.88 (ø124)	4.63 (118)	2.76 (70)	1.93 (49)	-	319 (145)
LHYM01-4C14DAY-AV	1/8 x 4 (0.1 x 4)	29.37 (746)	ø4.88 (ø124)	4.63 (118)	2.32 (59)	318 (145)	30.63 (778)	ø4.88 (ø124)	4.63 (118)	3.58 (91)	2.40 (61)	-	321 (146)
LHYM02-4C14DAY	1/4 x 4 (0.2 x 4)	29.37 (746)	ø4.88 (ø124)	4.63 (118)	2.32 (59)	318 (145)	30.63 (778)	ø4.88 (ø124)	4.63 (118)	3.58 (91)	2.40 (61)	-	321 (146)
LHYM02-4C14DAY-AV	1/4 x 4 (0.2 x 4)	30.16 (766)	ø4.88 (ø124)	4.63 (118)	2.32 (59)	321 (146)	31.42 (798)	ø4.88 (ø124)	4.63 (118)	3.58 (91)	2.40 (61)	-	324 (147)

Notes [1]: DM Dimension Symbol ø = Round Fan Cover  
DM Dimension Symbol = Square Fan Cover

LXXX-4XX0/4XX5 Frame sizes have equal dimensions, different ratings.

# Dimensions

## LHYM02-4C14DAY ▶ LHYM03-4C16DAY-AV

### Double Reduction Cyclo® LHYM-4C14DBY~4C16DBY

Minimum Engagement		
Frame Size	TT	
	inch	(mm)
4C	10.98	(279)

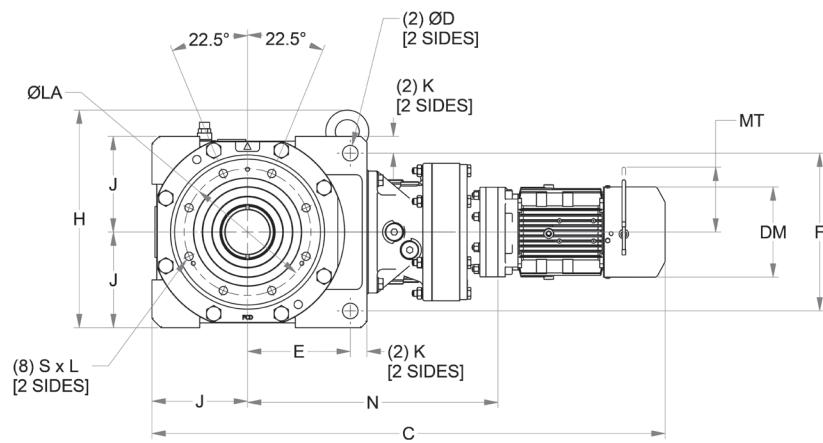
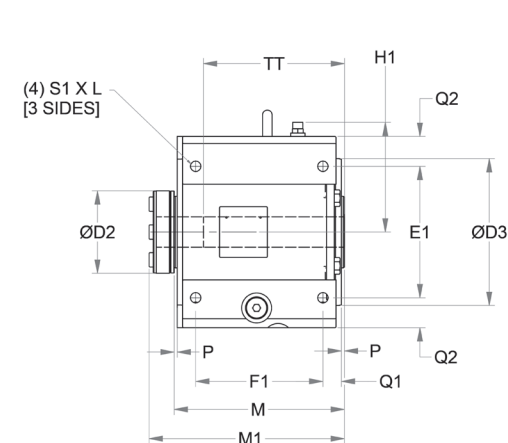
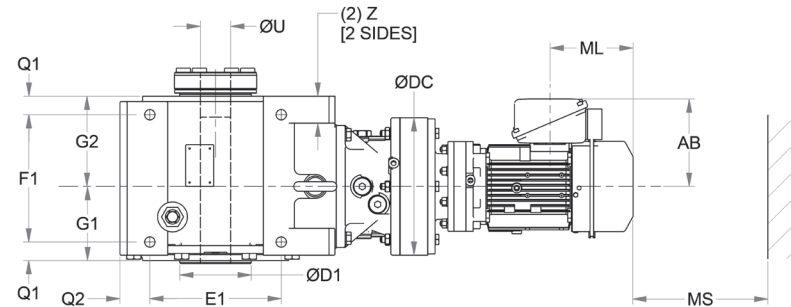

All dimensions are in inches (mm).  
For double reduction units ordered in the Y2 mounting configuration, please refer to page 2.133 for external lubricant piping dimensions.

Model	N	ØDC	J	E	F	K	Z	ØD	E1	F1	Q1	Q2	S1 x L	M
4C14DA	16.1 (410)	9.06 (230)	6.30 (160)	6.77 (172)	10.4 (264)	1.10 (28)	1.77 (45)	1.02 (26)	8.66 (220)	8.39 (213)	1.22 (31)	1.97 (50)	M20 x 1.30 (M20 x 33)	11.2 (285)
4C14DB	16.5 (419)	9.06 (230)												
4C14DC	17.1 (433)	9.06 (230)												
4C16DA	17.4 (442)	11.8 (300)												

Model	P	G1	G2	H	H1	ØLA	ØD3	S x L	M1	ØD1	ØD2	ØU	
												Std & Max	Min
4C14DA, 4C14DB, 4C14DC, 4C16DA	0.20 (5)	4.88 (124)	5.94 (151)	14.3 (364)	7.20 (183)	8.35 (212)	9.61 (244)	M16 x 1.02 (M16 x 26)	12.8 (326)	4.72 (120)	5.43 (138)	2-15/16 (74.61)	2-3/16 (55.56)

All dimensions are in inches (mm)

Model	4 Pole Motor HP (kW)	Without Brake					With Brake						
		C	DM [1]	AB	ML	Weight lb (kg)	C	DM [1]	AB	ML	MS	MT	Weight lb (kg)
LHYM03-4C14DAY	1/3 x 4 (0.25 x 4)	29.37 (746)	ø4.88 (ø124)	4.63 (118)	2.32 (59)	318 (145)	30.63 (778)	ø4.88 (ø124)	4.63 (118)	3.58 (91)	2.40 (61)	-	321 (146)
LHYM03-4C14DAY-AV	1/3 x 4 (0.25 x 4)	30.16 (766)	ø4.88 (ø124)	4.63 (118)	2.32 (59)	321 (146)	31.42 (798)	ø4.88 (ø124)	4.63 (118)	3.58 (91)	2.40 (61)	-	324 (147)
LHYM05-4C14DAY	1/2 x 4 (0.4 x 4)	30.16 (766)	ø4.88 (ø124)	4.63 (118)	2.32 (59)	321 (146)	31.42 (798)	ø4.88 (ø124)	4.63 (118)	3.58 (91)	2.40 (61)	-	324 (147)
LHYM02-4C14DBY	1/4 x 4 (0.2 x 4)	29.73 (755)	ø4.88 (ø124)	4.63 (118)	2.32 (59)	325 (148)	30.99 (787)	ø4.88 (ø124)	4.63 (118)	3.58 (91)	2.40 (61)	-	328 (149)
LHYM02-4C14DBY-AV	1/4 x 4 (0.2 x 4)	30.51 (775)	ø4.88 (ø124)	4.63 (118)	2.32 (59)	328 (149)	31.77 (807)	ø4.88 (ø124)	4.63 (118)	3.58 (91)	2.40 (61)	-	332 (151)
LHYM03-4C14DBY	1/3 x 4 (0.25 x 4)	29.73 (755)	ø4.88 (ø124)	4.63 (118)	2.32 (59)	325 (148)	30.99 (787)	ø4.88 (ø124)	4.63 (118)	3.58 (91)	2.40 (61)	-	328 (149)
LHYM03-4C14DBY-AV	1/3 x 4 (0.25 x 4)	30.51 (775)	ø4.88 (ø124)	4.63 (118)	2.32 (59)	328 (149)	31.77 (807)	ø4.88 (ø124)	4.63 (118)	3.58 (91)	2.40 (61)	-	332 (151)
LHYM05-4C14DBY	1/2 x 4 (0.4 x 4)	30.51 (775)	ø4.88 (ø124)	4.63 (118)	2.32 (59)	328 (149)	31.77 (807)	ø4.88 (ø124)	4.63 (118)	3.58 (91)	2.40 (61)	-	332 (151)
LHYM05-4C14DBY-AV	1/2 x 4 (0.4 x 4)	32.13 (816)	ø5.94 (ø151)	5.67 (144)	3.82 (97)	336 (153)	33.82 (859)	ø5.94 (ø151)	5.67 (144)	5.51 (140)	3.66 (93)	3.94 (100)	341 (155)
LHYM08-4C14DBY	3/4 x 4 (0.55 x 4)	32.13 (816)	ø5.94 (ø151)	5.67 (144)	3.82 (97)	333 (151)	33.82 (859)	ø5.94 (ø151)	5.67 (144)	5.51 (140)	3.66 (93)	3.94 (100)	339 (154)
LHYM08-4C14DBY-AV	3/4 x 4 (0.55 x 4)	33.43 (849)	ø6.30 (ø160)	5.86 (149)	3.94 (100)	344 (156)	35.87 (911)	ø6.30 (ø160)	5.86 (149)	6.38 (162)	4.53 (115)	4.29 (109)	355 (161)
LHYM1-4C14DBY-EP	1 x 4 (0.75 x 4)	33.86 (860)	6.22 (158)	5.98 (152)	3.82 (97)	349 (159)	36.36 (924)	6.22 (158)	5.98 (152)	6.32 (161)	4.80 (122)	4.25 (108)	359 (163)
LHYM1H-4C14DBY-EP	1.5 x 4 (1.1 x 4)	34.92 (887)	6.57 (167)	6.16 (156)	3.82 (97)	356 (162)	37.66 (957)	6.57 (167)	6.16 (156)	6.56 (167)	5.04 (128)	4.61 (117)	368 (167)
LHYM2-4C14DBY-EP	2 x 4 (1.5 x 4)	34.92 (887)	6.57 (167)	6.16 (156)	3.82 (97)	359 (163)	37.66 (957)	6.57 (167)	6.16 (156)	6.56 (167)	5.04 (128)	4.61 (117)	371 (168)
LHYM08-4C14DCY	3/4 x 4 (0.55 x 4)	32.68 (830)	ø5.94 (ø151)	5.67 (144)	3.82 (97)	336 (152)	34.37 (873)	ø5.94 (ø151)	5.67 (144)	5.51 (140)	3.66 (93)	3.94 (100)	341 (155)
LHYM08-4C14DCY-AV	3/4 x 4 (0.55 x 4)	33.98 (863)	ø6.30 (ø160)	5.86 (149)	3.94 (100)	346 (157)	36.42 (925)	ø6.30 (ø160)	5.86 (149)	6.38 (162)	4.53 (115)	4.29 (109)	357 (162)
LHYM1-4C14DCY-EP	1 x 4 (0.75 x 4)	34.41 (874)	6.22 (158)	5.98 (152)	3.82 (97)	351 (160)	36.91 (938)	6.22 (158)	5.98 (152)	6.32 (161)	4.80 (122)	4.25 (108)	361 (164)
LHYM1H-4C14DCY-EP	1.5 x 4 (1.1 x 4)	35.47 (901)	6.57 (167)	6.16 (156)	3.82 (97)	359 (163)	38.21 (971)	6.57 (167)	6.16 (156)	6.56 (167)	5.04 (128)	4.61 (117)	370 (168)
LHYM2-4C14DCY-EP	2 x 4 (1.5 x 4)	35.47 (901)	6.57 (167)	6.16 (156)	3.82 (97)	362 (164)	38.21 (971)	6.57 (167)	6.16 (156)	6.56 (167)	5.04 (128)	4.61 (117)	373 (170)
LHYM3-4C14DCY-EP	3 x 4 (2.2 x 4)	36.30 (922)	7.24 (184)	6.71 (170)	4.53 (115)	378 (172)	39.37 (1000)	7.24 (184)	6.71 (170)	7.60 (193)	5.43 (138)	5.04 (128)	394 (179)
LHYM02-4C16DAY	1/4 x 4 (0.2 x 4)	30.65 (778)	ø4.88 (ø124)	4.63 (118)	2.32 (59)	376 (171)	31.91 (810)	ø4.88 (ø124)	4.63 (118)	3.58 (91)	2.40 (61)	-	379 (172)
LHYM02-4C16DAY-AV	1/4 x 4 (0.2 x 4)	31.43 (798)	ø4.88 (ø124)	4.63 (118)	2.32 (59)	379 (172)	32.69 (830)	ø4.88 (ø124)	4.63 (118)	3.58 (91)	2.40 (61)	-	382 (174)
LHYM03-4C16DAY	1/3 x 4 (0.25 x 4)	30.65 (778)	ø4.88 (ø124)	4.63 (118)	2.32 (59)	376 (171)	31.91 (810)	ø4.88 (ø124)	4.63 (118)	3.58 (91)	2.40 (61)	-	379 (172)
LHYM03-4C16DAY-AV	1/3 x 4 (0.25 x 4)	31.43 (798)	ø4.88 (ø124)	4.63 (118)	2.32 (59)	379 (172)	32.69 (830)	ø4.88 (ø124)	4.63 (118)	3.58 (91)	2.40 (61)	-	382 (174)
LHYM05-4C16DAY	1/2 x 4 (0.4 x 4)	31.43 (798)	ø4.88 (ø124)	4.63 (118)	2.32 (59)	379 (172)	32.69 (830)	ø4.88 (ø124)	4.63 (118)	3.58 (91)	2.40 (61)	-	382 (174)
LHYM05-4C16DAY-AV	1/2 x 4 (0.4 x 4)	33.05 (839)	ø5.94 (ø151)	5.67 (144)	3.82 (97)	386 (176)	34.74 (882)	ø5.94 (ø151)	5.67 (144)	5.51 (140)	3.66 (93)	3.94 (100)	392 (178)
LHYM08-4C16DAY	3/4 x 4 (0.55 x 4)	33.05 (839)	ø5.94 (ø151)	5.67 (144)	3.82 (97)	384 (174)	34.74 (882)	ø5.94 (ø151)	5.67 (144)	5.51 (140)	3.66 (93)	3.94 (100)	390 (177)

Notes [1]: DM Dimension Symbol ø = Round Fan Cover  
DM Dimension Symbol = Square Fan Cover

LXXX-4XX0/4XX5 Frame sizes have equal dimensions, different ratings.

Dimensions

Dimensions



# Dimensions

## LHYM05-4C16DAY ▶ LHYM08-4D16DBY-AV

### Double Reduction Cyclo® LHYM-4C16DAY~4D16DBY

Minimum Engagement		
Frame Size	TT	
	inch	(mm)
4C	10.98	(279)
4D	12.83	(326)

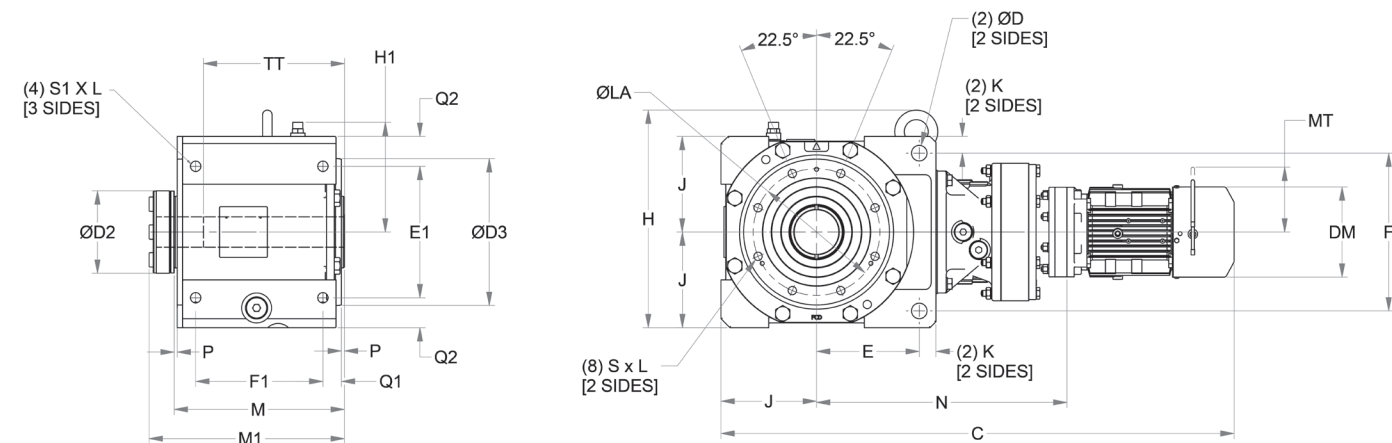
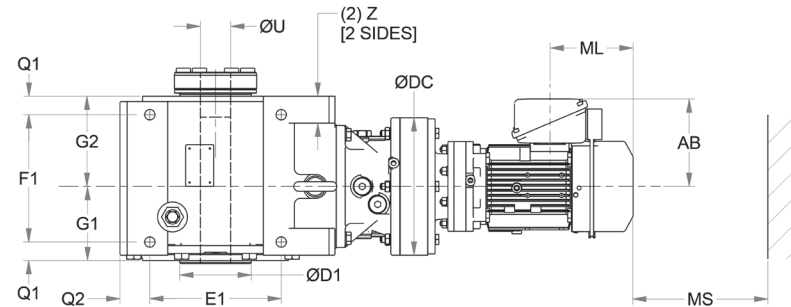

All dimensions are in inches (mm).  
For double reduction units ordered in the Y2 mounting configuration, please refer to page 2.133 for external lubricant piping dimensions.

Model	N	ØDC	J	E	F	K	Z	ØD	E1	F1	Q1	Q2	S1 x L	M
4C16DA	17.4 (442)	11.8 (300)	6.30 (160)	6.77 (172)	10.4 (264)	1.10 (28)	1.77 (45)	1.02 (26)	8.66 (220)	8.39 (213)	1.22 (31)	1.97 (50)	M20 x 1.30 (M20 x 33)	11.2 (285)
4C16DB	18.0 (456)	11.8 (300)												
4C16DC	18.0 (458)	11.8 (300)												
4D16DA	20.2 (514)	11.8 (300)	7.48 (190)	7.60 (193)	12.2 (310)	1.38 (35)	2.17 (55)	1.30 (33)	9.84 (250)	10.0 (254)	1.42 (36)	2.56 (65)	M24 x 1.57 (M24 x 40)	13.4 (340)
4D16DB	20.8 (528)	11.8 (300)												

Model	P	G1	G2	H	H1	ØLA	ØD3	S x L	M1	ØD1	ØD2	ØU	
												Std & Max	Min
4C16DA, 4C16DB, 4C16DC	0.20 (5)	4.88 (124)	5.94 (151)	14.3 (364)	7.20 (183)	8.35 (212)	9.61 (244)	M16 x 1.02 (M16 x 26)	12.8 (326)	4.72 (120)	5.43 (138)	2-15/16 (74.61)	2-3/16 (55.56)
4D16DA, 4D16DB	0.28 (7)	5.83 (148)	7.01 (178)	16.7 (424)	8.39 (213)	10.0 (255)	11.6 (295)	M20 x 1.30 (M20 x 33)	15.0 (381)	5.51 (140)	5.98 (152)	3-7/16 (87.31)	2-7/16 (61.91)

All dimensions are in inches (mm)

Model	4 Pole Motor HP (kW)	Without Brake					With Brake						
		C	DM <sup>[1]</sup>	AB	ML	Weight lb (kg)	C	DM <sup>[1]</sup>	AB	ML	MS	MT	Weight lb (kg)
LHYM08-4C16DAY-AV	3/4 x 4 (0.55 x 4)	34.35 (872)	ø6.30 (ø160)	5.86 (149)	3.94 (100)	395 (179)	36.79 (934)	ø6.30 (ø160)	5.86 (149)	6.38 (162)	4.53 (115)	4.29 (109)	405 (184)
LHYM1-4C16DAY-EP	1 x 4 (0.75 x 4)	34.78 (883)	6.22 (158)	5.98 (152)	3.82 (97)	400 (182)	37.28 (947)	6.22 (158)	5.98 (152)	6.32 (161)	4.80 (122)	4.25 (108)	409 (186)
LHYM1H-4C16DAY-EP	1.5 x 4 (1.1 x 4)	35.84 (910)	6.57 (167)	6.16 (156)	3.82 (97)	407 (185)	38.58 (980)	6.57 (167)	6.16 (156)	6.56 (167)	5.04 (128)	4.61 (117)	419 (190)
LHYM2-4C16DAY-EP	2 x 4 (1.5 x 4)	35.84 (910)	6.57 (167)	6.16 (156)	3.82 (97)	410 (186)	38.58 (980)	6.57 (167)	6.16 (156)	6.56 (167)	5.04 (128)	4.61 (117)	421 (191)
LHYM1-4C16DBY-EP	1 x 4 (0.75 x 4)	35.33 (897)	6.22 (158)	5.98 (152)	3.82 (97)	404 (184)	37.83 (961)	6.22 (158)	5.98 (152)	6.32 (161)	4.80 (122)	4.25 (108)	414 (188)
LHYM1H-4C16DBY-EP	1.5 x 4 (1.1 x 4)	36.39 (924)	6.57 (167)	6.16 (156)	3.82 (97)	412 (187)	39.13 (994)	6.57 (167)	6.16 (156)	6.56 (167)	5.04 (128)	4.61 (117)	423 (192)
LHYM2-4C16DBY-EP	2 x 4 (1.5 x 4)	36.39 (924)	6.57 (167)	6.16 (156)	3.82 (97)	415 (188)	39.13 (994)	6.57 (167)	6.16 (156)	6.56 (167)	5.04 (128)	4.61 (117)	426 (194)
LHYM3-4C16DBY-EP	3 x 4 (2.2 x 4)	37.22 (945)	7.24 (184)	6.71 (170)	4.53 (115)	431 (196)	40.29 (1023)	7.24 (184)	6.71 (170)	7.60 (193)	5.43 (138)	5.04 (128)	447 (203)
LHYM08-4C16DCY	3/4 x 4 (0.55 x 4)	33.66 (855)	ø5.94 (ø151)	5.67 (144)	3.82 (97)	421 (191)	35.35 (898)	ø5.94 (ø151)	5.67 (144)	5.51 (140)	3.66 (93)	3.94 (100)	427 (194)
LHYM08-4C16DCY-AV	3/4 x 4 (0.55 x 4)	34.96 (888)	ø6.30 (ø160)	5.86 (149)	3.94 (100)	429 (195)	37.40 (950)	ø6.30 (ø160)	5.86 (149)	6.38 (162)	4.53 (115)	4.29 (109)	440 (200)
LHYM02-4D16DAY	1/4 x 4 (0.2 x 4)	34.67 (881)	ø4.88 (ø124)	4.63 (118)	2.32 (59)	522 (237)	35.93 (913)	ø4.88 (ø124)	4.63 (118)	3.58 (91)	2.40 (61)	-	525 (238)
LHYM02-4D16DAY-AV	1/4 x 4 (0.2 x 4)	35.46 (901)	ø4.88 (ø124)	4.63 (118)	2.32 (59)	525 (238)	36.72 (933)	ø4.88 (ø124)	4.63 (118)	3.58 (91)	2.40 (61)	-	528 (240)
LHYM03-4D16DAY	1/3 x 4 (0.25 x 4)	34.67 (881)	ø4.88 (ø124)	4.63 (118)	2.32 (59)	522 (237)	35.93 (913)	ø4.88 (ø124)	4.63 (118)	3.58 (91)	2.40 (61)	-	525 (238)
LHYM03-4D16DAY-AV	1/3 x 4 (0.25 x 4)	35.46 (901)	ø4.88 (ø124)	4.63 (118)	2.32 (59)	525 (238)	36.72 (933)	ø4.88 (ø124)	4.63 (118)	3.58 (91)	2.40 (61)	-	528 (240)
LHYM05-4D16DAY	1/2 x 4 (0.4 x 4)	35.46 (901)	ø4.88 (ø124)	4.63 (118)	2.32 (59)	525 (238)	36.72 (933)	ø4.88 (ø124)	4.63 (118)	3.58 (91)	2.40 (61)	-	528 (240)
LHYM05-4D16DAY-AV	1/2 x 4 (0.4 x 4)	37.07 (942)	ø5.94 (ø151)	5.67 (144)	3.82 (97)	532 (242)	38.77 (985)	ø5.94 (ø151)	5.67 (144)	5.51 (140)	3.66 (93)	3.94 (100)	538 (244)
LHYM08-4D16DAY	3/4 x 4 (0.55 x 4)	37.07 (942)	ø5.94 (ø151)	5.67 (144)	3.82 (97)	530 (241)	38.77 (985)	ø5.94 (ø151)	5.67 (144)	5.51 (140)	3.66 (93)	3.94 (100)	536 (243)
LHYM08-4D16DAY-AV	3/4 x 4 (0.55 x 4)	38.37 (975)	ø6.30 (ø160)	5.86 (149)	3.94 (100)	541 (245)	40.81 (1037)	ø6.30 (ø160)	5.86 (149)	6.38 (162)	4.53 (115)	4.29 (109)	551 (250)
LHYM1-4D16DAY-EP	1 x 4 (0.75 x 4)	38.81 (986)	6.22 (158)	5.98 (152)	3.82 (97)	545 (248)	41.31 (1049)	6.22 (158)	5.98 (152)	6.32 (161)	4.80 (122)	4.25 (108)	555 (252)
LHYM1H-4D16DAY-EP	1.5 x 4 (1.1 x 4)	39.87 (1013)	6.57 (167)	6.16 (156)	3.82 (97)	553 (251)	42.60 (1082)	6.57 (167)	6.16 (156)	6.56 (167)	5.04 (128)	4.61 (117)	565 (256)
LHYM2-4D16DAY-EP	2 x 4 (1.5 x 4)	39.87 (1013)	6.57 (167)	6.16 (156)	3.82 (97)	556 (252)	42.60 (1082)	6.57 (167)	6.16 (156)	6.56 (167)	5.04 (128)	4.61 (117)	567 (258)
LHYM08-4D16DBY	3/4 x 4 (0.55 x 4)	37.62 (956)	ø5.94 (ø151)	5.67 (144)	3.82 (97)	534 (243)	39.32 (999)	ø5.94 (ø151)	5.67 (144)	5.51 (140)	3.66 (93)	3.94 (100)	540 (245)
LHYM08-4D16DBY-AV	3/4 x 4 (0.55 x 4)	38.92 (989)	ø6.30 (ø160)	5.86 (149)	3.94 (100)	545 (248)	41.36 (1051)	ø6.30 (ø160)	5.86 (149)	6.38 (162)	4.53 (115)	4.29 (109)	556 (252)
LHYM1-4D16DBY-EP	1 x 4 (0.75 x 4)	39.36 (1000)	6.22 (158)	5.98 (152)	3.82 (97)	550 (250)	41.86 (1063)	6.22 (158)	5.98 (152)	6.32 (161)	4.80 (122)	4.25 (108)	560 (254)
LHYM1H-4D16DBY-EP	1.5 x 4 (1.1 x 4)	40.42 (1027)	6.57 (167)	6.16 (156)	3.82 (97)	558 (253)	43.16 (1096)	6.57 (167)	6.16 (156)	6.56 (167)	5.04 (128)	4.61 (117)	569 (258)
LHYM2-4D16DBY-EP	2 x 4 (1.5 x 4)	40.42 (1027)	6.57 (167)	6.16 (156)	3.82 (97)	560 (255)	43.16 (1096)	6.57 (167)	6.16 (156)	6.56 (167)	5.04 (128)	4.61 (117)	572 (260)
LHYM3-4D16DBY-EP	3 x 4 (2.2 x 4)	41.25 (1048)	7.24 (184)	6.71 (170)	4.53 (115)	577 (262)	44.32 (1126)	7.24 (184)	6.71 (170)	7.60 (193)	5.43 (138)	5.04 (128)	593 (269)

Notes [1]: DM Dimension Symbol ø = Round Fan Cover  
DM Dimension Symbol = Square Fan Cover

LXXX-4XX0/4XX5 Frame sizes have equal dimensions, different ratings.



# Dimensions

## Double Reduction Cyclo® LHYM-4D16DBY~4D17DCY

Minimum Engagement		
Frame Size	TT	
	inch	(mm)
4D	12.83	(326)

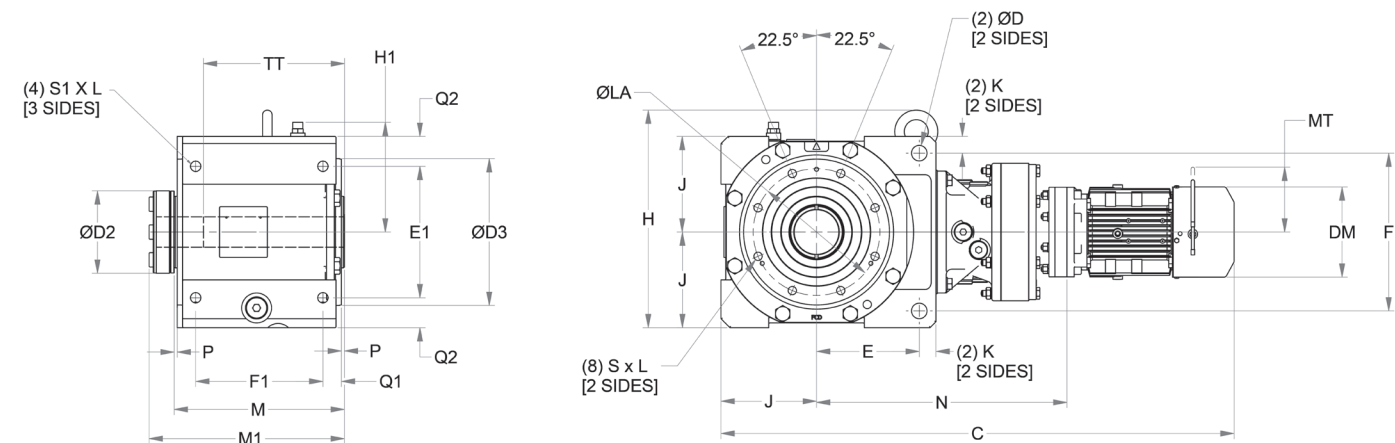
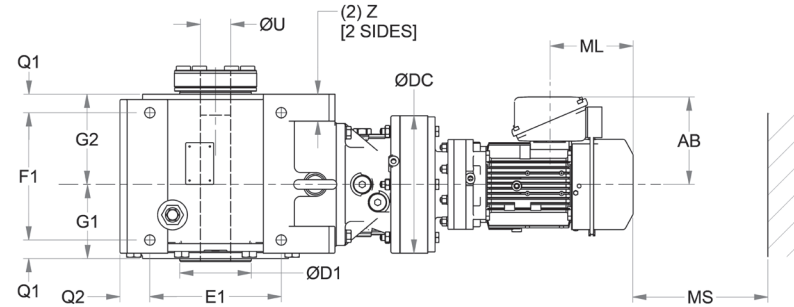

All dimensions are in inches (mm).  
For double reduction units ordered in the Y2 mounting configuration, please refer to page 2.133 for external lubricant piping dimensions.

Model	N	ØDC	J	E	F	K	Z	ØD	E1	F1	Q1	Q2	S1 x L	M
4D16DB	18.0 (456)	11.8 (300)	7.48 (190)	7.60 (193)	12.2 (310)	1.38 (35)	2.17 (55)	1.30 (33)	9.84 (250)	10.0 (254)	1.42 (36)	2.56 (65)	M24 x 1.57 (M24 x 40)	13.4 (340)
4D16DC	18.0 (458)	11.8 (300)												
4D17DA	20.2 (514)	11.8 (300)												
4D17DB	20.8 (528)	11.8 (300)												
4D17DC	20.8 (527)	13.4 (340)												

Model	P	G1	G2	H	H1	ØLA	ØD3	S x L	M1	ØD1	ØD2	ØU	
												Std & Max	Min
4D16DB, 4D16DC, 4D17DA, 4D17DB, 4D17DC	0.28 (7)	5.83 (148)	7.01 (178)	16.7 (424)	8.39 (213)	10.0 (255)	11.6 (295)	M20 x 1.30 (M20 x 33)	15.0 (381)	5.51 (140)	5.98 (152)	3-7/16 (87.31)	2-7/16 (61.91)

## LHYM1-4D16DBY-EP ▶ LHYM5-4D17DCY-EP

All dimensions are in inches (mm)

Model	4 Pole Motor HP (kW)	Without Brake					With Brake						
		C	DM <sup>[1]</sup>	AB	ML	Weight lb (kg)	C	DM <sup>[1]</sup>	AB	ML	MS	MT	Weight lb (kg)
LHYM2-4D16DCY-EP	2 x 4 (1.5 x 4)	40.48 (1028)	6.57 (167)	6.16 (156)	3.82 (97)	575 (261)	43.21 (1098)	6.57 (167)	6.16 (156)	6.56 (167)	5.04 (128)	4.61 (117)	586 (266)
LHYM5-4D16DCY-EP	5 x 4 (3.7 x 4)	41.34 (1050)	8.74 (222)	7.34 (186)	4.65 (118)	613 (278)	44.91 (1141)	8.74 (222)	7.34 (186)	8.21 (209)	6.02 (153)	6.30 (160)	637 (289)
LHYM02-4D17DAY	1/4 x 4 (0.2 x 4)	34.46 (875)	ø4.88 (ø124)	4.63 (118)	2.32 (59)	553 (251)	35.72 (907)	ø4.88 (ø124)	4.63 (118)	3.58 (91)	2.40 (61)	-	556 (252)
LHYM02-4D17DAY-AV	1/4 x 4 (0.2 x 4)	35.25 (895)	ø4.88 (ø124)	4.63 (118)	2.32 (59)	556 (252)	36.51 (927)	ø4.88 (ø124)	4.63 (118)	3.58 (91)	2.40 (61)	-	559 (254)
LHYM03-4D17DAY	1/3 x 4 (0.25 x 4)	34.46 (875)	ø4.88 (ø124)	4.63 (118)	2.32 (59)	553 (251)	35.72 (907)	ø4.88 (ø124)	4.63 (118)	3.58 (91)	2.40 (61)	-	556 (252)
LHYM03-4D17DAY-AV	1/3 x 4 (0.25 x 4)	35.25 (895)	ø4.88 (ø124)	4.63 (118)	2.32 (59)	556 (252)	36.51 (927)	ø4.88 (ø124)	4.63 (118)	3.58 (91)	2.40 (61)	-	559 (254)
LHYM05-4D17DAY	1/2 x 4 (0.4 x 4)	35.25 (895)	ø4.88 (ø124)	4.63 (118)	2.32 (59)	556 (252)	36.51 (927)	ø4.88 (ø124)	4.63 (118)	3.58 (91)	2.40 (61)	-	559 (254)
LHYM05-4D17DAY-AV	1/2 x 4 (0.4 x 4)	36.86 (936)	ø5.94 (ø151)	5.67 (144)	3.82 (97)	563 (256)	38.56 (979)	ø5.94 (ø151)	5.67 (144)	5.51 (140)	3.66 (93)	3.94 (100)	569 (258)
LHYM08-4D17DAY	3/4 x 4 (0.55 x 4)	36.86 (936)	ø5.94 (ø151)	5.67 (144)	3.82 (97)	561 (255)	38.56 (979)	ø5.94 (ø151)	5.67 (144)	5.51 (140)	3.66 (93)	3.94 (100)	566 (257)
LHYM08-4D17DAY-AV	3/4 x 4 (0.55 x 4)	38.16 (969)	ø6.30 (ø160)	5.86 (149)	3.94 (100)	571 (259)	40.60 (1031)	ø6.30 (ø160)	5.86 (149)	6.38 (162)	4.53 (115)	4.29 (109)	582 (264)
LHYM1-4D17DAY-EP	1 x 4 (0.75 x 4)	38.60 (980)	6.22 (158)	5.98 (152)	3.82 (97)	576 (262)	41.10 (1044)	6.22 (158)	5.98 (152)	6.32 (161)	4.80 (122)	4.25 (108)	586 (266)
LHYM1H-4D17DAY-EP	1.5 x 4 (1.1 x 4)	39.66 (1007)	6.57 (167)	6.16 (156)	3.82 (97)	584 (265)	42.40 (1077)	6.57 (167)	6.16 (156)	6.56 (167)	5.04 (128)	4.61 (117)	595 (270)
LHYM2-4D17DAY-EP	2 x 4 (1.5 x 4)	39.66 (1007)	6.57 (167)	6.16 (156)	3.82 (97)	587 (266)	42.40 (1077)	6.57 (167)	6.16 (156)	6.56 (167)	5.04 (128)	4.61 (117)	598 (272)
LHYM1-4D17DBY-EP	1 x 4 (0.75 x 4)	39.15 (994)	6.22 (158)	5.98 (152)	3.82 (97)	581 (264)	41.65 (1058)	6.22 (158)	5.98 (152)	6.32 (161)	4.80 (122)	4.25 (108)	591 (268)
LHYM1H-4D17DBY-EP	1.5 x 4 (1.1 x 4)	40.21 (1021)	6.57 (167)	6.16 (156)	3.82 (97)	588 (267)	42.95 (1091)	6.57 (167)	6.16 (156)	6.56 (167)	5.04 (128)	4.61 (117)	600 (272)
LHYM2-4D17DBY-EP	2 x 4 (1.5 x 4)	40.21 (1021)	6.57 (167)	6.16 (156)	3.82 (97)	591 (269)	42.95 (1091)	6.57 (167)	6.16 (156)	6.56 (167)	5.04 (128)	4.61 (117)	603 (274)
LHYM3-4D17DBY-EP	3 x 4 (2.2 x 4)	41.04 (1042)	7.24 (184)	6.71 (170)	4.53 (115)	607 (276)	44.11 (1120)	7.24 (184)	6.71 (170)	7.60 (193)	5.43 (138)	5.04 (128)	624 (283)
LHYM08-4D17DCY	3/4 x 4 (0.55 x 4)	37.55 (954)	ø5.94 (ø151)	5.67 (144)	3.82 (97)	578 (262)	39.25 (997)	ø5.94 (ø151)	5.67 (144)	5.51 (140)	3.66 (93)	3.94 (100)	584 (265)
LHYM08-4D17DCY-AV	3/4 x 4 (0.55 x 4)	38.85 (987)	ø6.30 (ø160)	5.86 (149)	3.94 (100)	586 (266)	41.29 (1049)	ø6.30 (ø160)	5.86 (149)	6.38 (162)	4.53 (115)	4.29 (109)	597 (271)
LHYM2-4D17DCY-EP	2 x 4 (1.5 x 4)	40.35 (1025)	6.57 (167)	6.16 (156)	3.82 (97)	601 (273)	43.08 (1094)	6.57 (167)	6.16 (156)	6.56 (167)	5.04 (128)	4.61 (117)	613 (278)
LHYM3-4D17DCY-EP	3 x 4 (2.2 x 4)	39.76 (1010)	7.24 (184)	6.71 (170)	4.53 (115)	614 (279)	42.83 (1088)	7.24 (184)	6.71 (170)	7.60 (193)	5.43 (138)	5.04 (128)	631 (286)
LHYM5-4D17DCY-EP	5 x 4 (3.7 x 4)	41.21 (1047)	8.74 (222)	7.34 (186)	4.65 (118)	640 (290)	44.78 (1137)	8.74 (222)	7.34 (186)	8.21 (209)	6.02 (153)	6.30 (160)	664 (301)
LHYM02-4E17DAY	1/4 x 4 (0.2 x 4)	36.43 (925)	ø4.88 (ø124)	4.63 (118)	2.32 (59)	720 (327)	37.69 (957)	ø4.88 (ø124)	4.63 (118)	3.58 (91)	2.40 (61)	-	723 (328)
LHYM02-4E17DAY-AV	1/4 x 4 (0.2 x 4)	37.22 (945)	ø4.88 (ø124)	4.63 (118)	2.32 (59)	723 (328)	38.48 (977)	ø4.88 (ø124)	4.63 (118)	3.58 (91)	2.40 (61)	-	726 (330)
LHYM03-4E17DAY	1/3 x 4 (0.25 x 4)	36.43 (925)	ø4.88 (ø124)	4.63 (118)	2.32 (59)	720 (327)	37.69 (957)	ø4.88 (ø124)	4.63 (118)	3.58 (91)	2.40 (61)	-	723 (328)
LHYM03-4E17DAY-AV	1/3 x 4 (0.25 x 4)	37.22 (945)	ø4.88 (ø124)	4.63 (118)	2.32 (59)	723 (328)	38.48 (977)	ø4.88 (ø124)	4.63 (118)	3.58 (91)	2.40 (61)	-	726 (330)
LHYM05-4E17DAY	1/2 x 4 (0.4 x 4)	37.22 (945)	ø4.88 (ø124)	4.63 (118)	2.32 (59)	723 (328)	38.48 (977)	ø4.88 (ø124)	4.63 (118)	3.58 (91)	2.40 (61)	-	726 (330)

Notes [1]: DM Dimension Symbol ø = Round Fan Cover  
DM Dimension Symbol = Square Fan Cover

LXXX-4XX0/4XX5 Frame sizes have equal dimensions, different ratings.

# Dimensions

## LHYM02-4E17DAY ▶ LHYM1-4E18DAY-EP

### Double Reduction Cyclo® LHYM-4E17DAY~4E18DAY

Minimum Engagement		
Frame Size	TT	
	inch	(mm)
4E	14.1	(359)

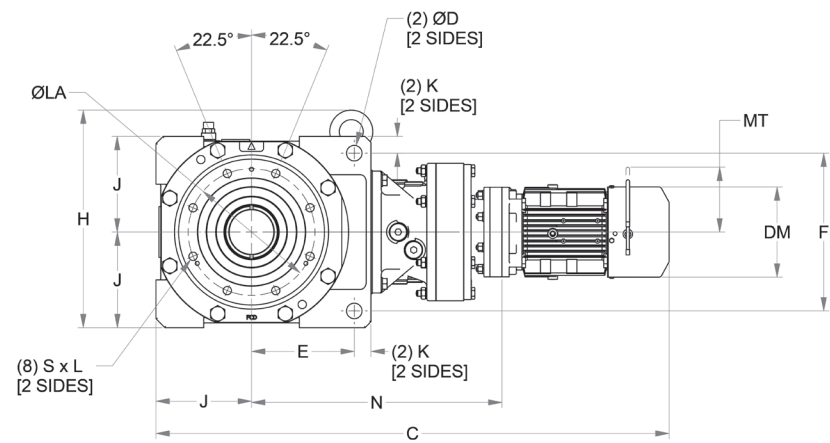
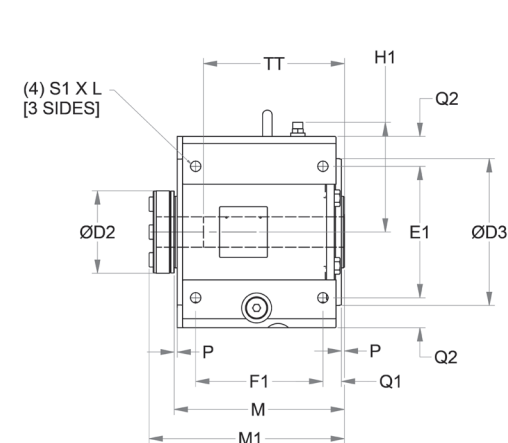
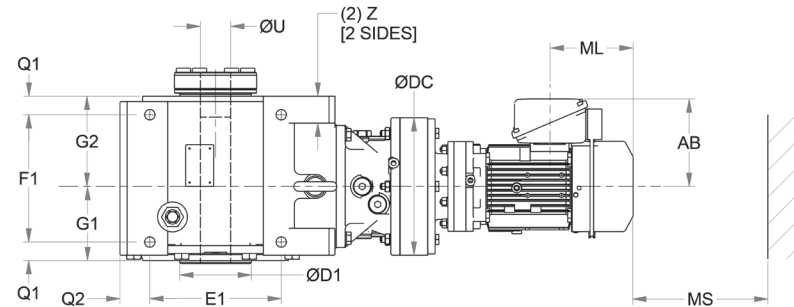

All dimensions are in inches (mm).  
For double reduction units ordered in the Y2 mounting configuration, please refer to page 2.133 for external lubricant piping dimensions.

Model	N	ØDC	J	E	F	K	Z	ØD	E1	F1	Q1	Q2	S1 x L	M
4E17DA	21.0 (534)	13.4 (340)	8.46 (215)	9.06 (230)	14.2 (360)	1.38 (35)	2.17 (55)	1.30 (33)	11.8 (300)	11.1 (283)	1.50 (38)	2.56 (65)	M24 x 1.57 (M24 x 40)	14.7 (373)
4E17DB	21.6 (548)	13.4 (340)												
4E17DC	21.7 (552)	13.4 (340)												
4E18DA	24.5 (621)	14.6 (370)												

Model	P	G1	G2	H	H1	ØLA	ØD3	S x L	M1	ØD1	ØD2	ØU	
												Std & Max	Min
4E17DA, 4E17DB 4E17DC, 4E18DA,	0.28 (7)	6.14 (156)	7.99 (203)	19.6 (498)	9.37 (238)	11.02 (280)	12.6 (320)	M20 x 1.38 (M20 x 35)	16.3 (414)	6.30 (160)	6.69 (170)	3-15/16 (100.01)	2-15/16 (74.61)

All dimensions are in inches (mm)

Model	4 Pole Motor HP (kW)	Without Brake					With Brake						
		C	DM <sup>[1]</sup>	AB	ML	Weight lb (kg)	C	DM <sup>[1]</sup>	AB	ML	MS	MT	Weight lb (kg)
LHYM05-4E17DAY-AV	1/2 x 4 (0.4 x 4)	38.83 (986)	ø5.94 (ø151)	5.67 (144)	3.82 (97)	730 (332)	40.53 (1029)	ø5.94 (ø151)	5.67 (144)	5.51 (140)	3.66 (93)	3.94 (100)	736 (334)
LHYM08-4E17DAY	3/4 x 4 (0.55 x 4)	38.83 (986)	ø5.94 (ø151)	5.67 (144)	3.82 (97)	728 (330)	40.53 (1029)	ø5.94 (ø151)	5.67 (144)	5.51 (140)	3.66 (93)	3.94 (100)	734 (333)
LHYM08-4E17DAY-AV	3/4 x 4 (0.55 x 4)	40.13 (1019)	ø6.30 (ø160)	5.86 (149)	3.94 (100)	739 (335)	42.57 (1081)	ø6.30 (ø160)	5.86 (149)	6.38 (162)	4.53 (115)	4.29 (109)	750 (340)
LHYM1-4E17DAY-EP	1 x 4 (0.75 x 4)	40.56 (1030)	6.22 (158)	5.98 (152)	3.82 (97)	744 (338)	43.06 (1094)	6.22 (158)	5.98 (152)	6.32 (161)	4.80 (122)	4.25 (108)	754 (342)
LHYM1H-4E17DAY-EP	1.5 x 4 (1.1 x 4)	41.63 (1057)	6.57 (167)	6.16 (156)	3.82 (97)	751 (341)	44.36 (1127)	6.57 (167)	6.16 (156)	6.56 (167)	5.04 (128)	4.61 (117)	763 (346)
LHYM2-4E17DAY-EP	2 x 4 (1.5 x 4)	41.63 (1057)	6.57 (167)	6.16 (156)	3.82 (97)	754 (342)	44.36 (1127)	6.57 (167)	6.16 (156)	6.56 (167)	5.04 (128)	4.61 (117)	766 (348)
LHYM1-4E17DBY-EP	1 x 4 (0.75 x 4)	41.12 (1044)	6.22 (158)	5.98 (152)	3.82 (97)	748 (340)	43.62 (1108)	6.22 (158)	5.98 (152)	6.32 (161)	4.80 (122)	4.25 (108)	758 (344)
LHYM1H-4E17DBY-EP	1.5 x 4 (1.1 x 4)	42.18 (1071)	6.57 (167)	6.16 (156)	3.82 (97)	756 (343)	44.92 (1141)	6.57 (167)	6.16 (156)	6.56 (167)	5.04 (128)	4.61 (117)	767 (348)
LHYM2-4E17DBY-EP	2 x 4 (1.5 x 4)	42.18 (1071)	6.57 (167)	6.16 (156)	3.82 (97)	759 (344)	44.92 (1141)	6.57 (167)	6.16 (156)	6.56 (167)	5.04 (128)	4.61 (117)	770 (350)
LHYM3-4E17DBY-EP	3 x 4 (2.2 x 4)	43.01 (1092)	7.24 (184)	6.71 (170)	4.53 (115)	775 (352)	46.08 (1170)	7.24 (184)	6.71 (170)	7.60 (193)	5.43 (138)	5.04 (128)	792 (359)
LHYM2-4E17DCY-EP	2 x 4 (1.5 x 4)	42.32 (1075)	6.57 (167)	6.16 (156)	3.82 (97)	768 (349)	45.05 (1144)	6.57 (167)	6.16 (156)	6.56 (167)	5.04 (128)	4.61 (117)	780 (354)
LHYM3-4E17DCY-EP	3 x 4 (2.2 x 4)	41.73 (1060)	7.24 (184)	6.71 (170)	4.53 (115)	781 (355)	44.80 (1138)	7.24 (184)	6.71 (170)	7.60 (193)	5.43 (138)	5.04 (128)	798 (362)
LHYM5-4E17DCY-EP	5 x 4 (3.7 x 4)	43.18 (1097)	8.74 (222)	7.34 (186)	4.65 (118)	807 (366)	46.75 (1187)	8.74 (222)	7.34 (186)	8.21 (209)	6.02 (153)	6.30 (160)	831 (377)
LHYM8-4E17DCY-EP	7.5 x 4 (5.5 x 4)	44.88 (1140)	8.74 (222)	7.34 (186)	4.65 (118)	841 (382)	48.44 (1230)	8.74 (222)	7.34 (186)	8.21 (209)	6.02 (153)	6.30 (160)	865 (392)
LHYM03-4E18DAY	1/3 x 4 (0.25 x 4)	37.26 (947)	ø4.88 (ø124)	4.63 (118)	2.32 (59)	818 (371)	38.52 (979)	ø4.88 (ø124)	4.63 (118)	3.58 (91)	2.40 (61)	-	821 (372)
LHYM03-4E18DAY-AV	1/3 x 4 (0.25 x 4)	38.05 (967)	ø4.88 (ø124)	4.63 (118)	2.32 (59)	821 (372)	39.31 (999)	ø4.88 (ø124)	4.63 (118)	3.58 (91)	2.40 (61)	-	824 (374)
LHYM05-4E18DAY	1/2 x 4 (0.4 x 4)	38.05 (967)	ø4.88 (ø124)	4.63 (118)	2.32 (59)	821 (372)	39.31 (999)	ø4.88 (ø124)	4.63 (118)	3.58 (91)	2.40 (61)	-	824 (374)
LHYM05-4E18DAY-AV	1/2 x 4 (0.4 x 4)	39.67 (1008)	ø5.94 (ø151)	5.67 (144)	3.82 (97)	828 (376)	41.36 (1051)	ø5.94 (ø151)	5.67 (144)	5.51 (140)	3.66 (93)	3.94 (100)	834 (378)
LHYM08-4E18DAY	3/4 x 4 (0.55 x 4)	39.67 (1008)	ø5.94 (ø151)	5.67 (144)	3.82 (97)	825 (375)	41.36 (1051)	ø5.94 (ø151)	5.67 (144)	5.51 (140)	3.66 (93)	3.94 (100)	831 (377)
LHYM08-4E18DAY-AV	3/4 x 4 (0.55 x 4)	40.96 (1041)	ø6.30 (ø160)	5.86 (149)	3.94 (100)	836 (380)	43.41 (1103)	ø6.30 (ø160)	5.86 (149)	6.38 (162)	4.53 (115)	4.29 (109)	847 (384)
LHYM1-4E18DAY-EP	1 x 4 (0.75 x 4)	41.40 (1052)	6.22 (158)	5.98 (152)	3.82 (97)	841 (382)	43.90 (1115)	6.22 (158)	5.98 (152)	6.32 (161)	4.80 (122)	4.25 (108)	851 (386)
LHYM1H-4E18DAY-EP	1.5 x 4 (1.1 x 4)	42.46 (1079)	6.57 (167)	6.16 (156)	3.82 (97)	848 (385)	45.20 (1148)	6.57 (167)	6.16 (156)	6.56 (167)	5.04 (128)	4.61 (117)	860 (390)
LHYM2-4E18DAY-EP	2 x 4 (1.5 x 4)	42.46 (1079)	6.57 (167)	6.16 (156)	3.82 (97)	851 (386)	45.20 (1148)	6.57 (167)	6.16 (156)	6.56 (167)	5.04 (128)	4.61 (117)	863 (392)
LHYM3-4E18DAY-EP	3 x 4 (2.2 x 4)	43.29 (1100)	7.24 (184)	6.71 (170)	4.53 (115)	867 (394)	46.36 (1178)	7.24 (184)	6.71 (170)	7.60 (193)	5.43 (138)	5.04 (128)	884 (401)
LHYM1H-4E18DBY-EP	1.5 x 4 (1.1 x 4)	43.35 (1101)	6.57 (167)	6.16 (156)	3.82 (97)	873 (396)	46.08 (1171)	6.57 (167)	6.16 (156)	6.56 (167)	5.04 (128)	4.61 (117)	884 (401)
LHYM2-4E18DBY-EP	2 x 4 (1.5 x 4)	43.35 (1101)	6.57 (167)	6.16 (156)	3.82 (97)	876 (397)	46.08 (1171)	6.57 (167)	6.16 (156)	6.56 (167)	5.04 (128)	4.61 (117)	887 (403)
LHYM3-4E18DBY-EP	3 x 4 (2.2 x 4)	42.76 (1086)	7.24 (184)	6.71 (170)	4.53 (115)	887 (403)	45.83 (1164)	7.24 (184)	6.71 (170)	7.60 (193)	5.43 (138)	5.04 (128)	904 (410)

Notes [1]: DM Dimension Symbol ø = Round Fan Cover  
DM Dimension Symbol = Square Fan Cover

LXXX-4XX0/4XX5 Frame sizes have equal dimensions, different ratings.

# Dimensions

## Double Reduction Cyclo® LHYM-4E18DAY ~ 4F19DAY

Minimum Engagement		
Frame Size	TT	
	inch	(mm)
4E	14.1	(359)
4F	16.2	(412)

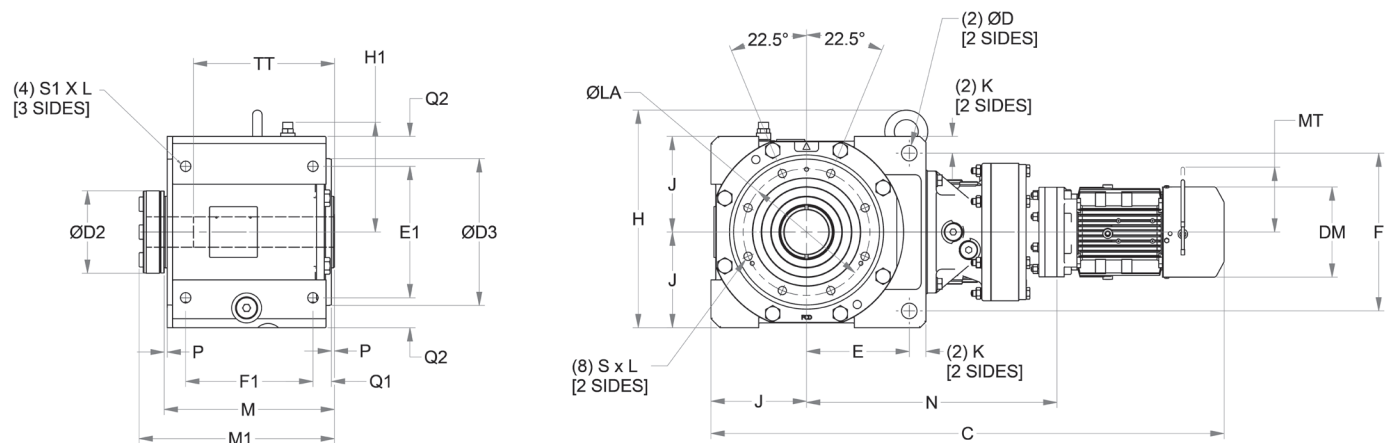
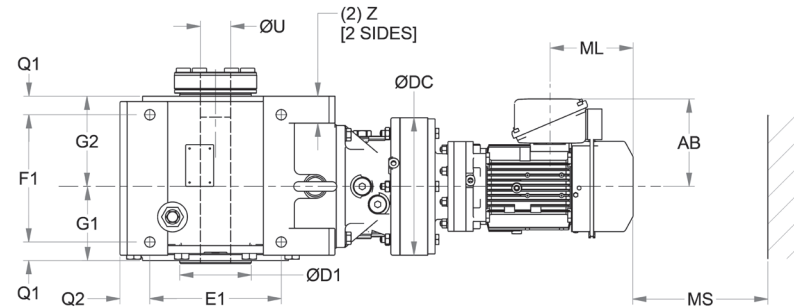

All dimensions are in inches (mm).

Model	N	ØDC	J	E	F	K	Z	ØD	E1	F1	Q1	Q2	S1 x L	M
4E18DA	24.5 (621)	14.6 (370)	8.46 (215)	9.06 (230)	14.2 (360)	1.38 (35)	2.17 (55)	1.30 (33)	11.8 (300)	11.1 (283)	1.50 (38)	2.56 (65)	M24 x 1.57 (M24 x 40)	14.7 (373)
4E18DB	25.3 (643)	14.6 (370)												
4F18DA	26.9 (684)	14.6 (370)	9.45 (240)	9.92 (252)	15.8 (400)	1.6 (40)	2.2 (55)	1.5 (39)	13.4 (340)	12.6 (320)	1.99 (50.5)	2.8 (70)	M30 x 1.97 (M30 x 50)	17.1 (435)
4F18DB	27.8 (706)	14.6 (370)												
4F19DA	28.3 (718)	16.9 (430)												

Model	P	G1	G2	H	H1	ØLA	ØD3	S x L	M1	ØD1	ØD2	ØU	
												Std & Max	Min
4E18DA, 4E18DB	0.28 (7)	6.14 (156)	7.99 (203)	19.6 (498)	9.37 (238)	11.02 (280)	12.6 (320)	M20 x 1.38 (M20 x 35)	16.3 (414)	6.30 (160)	6.69 (170)	3-15/16 (100.01)	2-15/16 (74.61)
4F18DA, 4F18DB 4F19DA	0.3 (7)	7.20 (183)	9.37 (238)	23.2 (590)	10.8 (273)	12.6 (320)	14.6 (370)	M24 x 1.97 (M24 x 50)	19.1 (486)	7.09 (180)	8.15 (207)	4-15/16 (125.41)	3-15/16 (100.01)

## LHYM1H-4E18DAY-EP ▶ LHYM05-4F19DAY

All dimensions are in inches (mm)

Model	4 Pole Motor HP (kW)	Without Brake					With Brake						
		C	DM <sup>[1]</sup>	AB	ML	Weight lb (kg)	C	DM <sup>[1]</sup>	AB	ML	MS	MT	Weight lb (kg)
LHYM5-4E18DBY-EP	5 x 4 (3.7 x 4)	44.02 (1118)	8.74 (222)	7.34 (186)	4.65 (118)	911 (414)	47.58 (1209)	8.74 (222)	7.34 (186)	8.21 (209)	6.02 (153)	6.30 (160)	935 (424)
LHYM8-4E18DBY-EP	7.5 x 4 (5.5 x 4)	45.71 (1161)	8.74 (222)	7.34 (186)	4.65 (118)	945 (429)	49.27 (1252)	8.74 (222)	7.34 (186)	8.21 (209)	6.02 (153)	6.30 (160)	969 (440)
LHYM03-4F18DAY	1/3 x 4 (0.25 x 4)	40.74 (1035)	ø4.88 (ø124)	4.63 (118)	2.32 (59)	1205 (547)	42.00 (1067)	ø4.88 (ø124)	4.63 (118)	3.58 (91)	2.40 (61)	-	1208 (548)
LHYM03-4F18DAY-AV	1/3 x 4 (0.25 x 4)	41.53 (1055)	ø4.88 (ø124)	4.63 (118)	2.32 (59)	1208 (548)	42.79 (1087)	ø4.88 (ø124)	4.63 (118)	3.58 (91)	2.40 (61)	-	1211 (550)
LHYM05-4F18DAY	1/2 x 4 (0.4 x 4)	41.53 (1055)	ø4.88 (ø124)	4.63 (118)	2.32 (59)	1208 (548)	42.79 (1087)	ø4.88 (ø124)	4.63 (118)	3.58 (91)	2.40 (61)	-	1211 (550)
LHYM05-4F18DAY-AV	1/2 x 4 (0.4 x 4)	43.14 (1096)	ø5.94 (ø151)	5.67 (144)	3.82 (97)	1215 (552)	44.84 (1139)	ø5.94 (ø151)	5.67 (144)	5.51 (140)	3.66 (93)	3.94 (100)	1221 (554)
LHYM08-4F18DAY	3/4 x 4 (0.55 x 4)	43.14 (1096)	ø5.94 (ø151)	5.67 (144)	3.82 (97)	1213 (550)	44.84 (1139)	ø5.94 (ø151)	5.67 (144)	5.51 (140)	3.66 (93)	3.94 (100)	1219 (553)
LHYM08-4F18DAY-AV	3/4 x 4 (0.55 x 4)	44.44 (1129)	ø6.30 (ø160)	5.86 (149)	3.94 (100)	1224 (555)	46.88 (1191)	ø6.30 (ø160)	5.86 (149)	6.38 (162)	4.53 (115)	4.29 (109)	1234 (560)
LHYM1-4F18DAY-EP	1 x 4 (0.75 x 4)	44.88 (1140)	6.22 (158)	5.98 (152)	3.82 (97)	1229 (558)	47.38 (1203)	6.22 (158)	5.98 (152)	6.32 (161)	4.80 (122)	4.25 (108)	1238 (562)
LHYM1H-4F18DAY-EP	1.5 x 4 (1.1 x 4)	45.94 (1167)	6.57 (167)	6.16 (156)	3.82 (97)	1236 (561)	48.68 (1236)	6.57 (167)	6.16 (156)	6.56 (167)	5.04 (128)	4.61 (117)	1248 (566)
LHYM2-4F18DAY-EP	2 x 4 (1.5 x 4)	45.94 (1167)	6.57 (167)	6.16 (156)	3.82 (97)	1239 (562)	48.68 (1236)	6.57 (167)	6.16 (156)	6.56 (167)	5.04 (128)	4.61 (117)	1250 (567)
LHYM3-4F18DAY-EP	3 x 4 (2.2 x 4)	46.77 (1188)	7.24 (184)	6.71 (170)	4.53 (115)	1255 (570)	49.84 (1266)	7.24 (184)	6.71 (170)	7.60 (193)	5.43 (138)	5.04 (128)	1272 (577)
LHYM1H-4F18DBY-EP	1.5 x 4 (1.1 x 4)	46.82 (1189)	6.57 (167)	6.16 (156)	3.82 (97)	1260 (572)	49.56 (1259)	6.57 (167)	6.16 (156)	6.56 (167)	5.04 (128)	4.61 (117)	1272 (577)
LHYM2-4F18DBY-EP	2 x 4 (1.5 x 4)	46.82 (1189)	6.57 (167)	6.16 (156)	3.82 (97)	1263 (573)	49.56 (1259)	6.57 (167)	6.16 (156)	6.56 (167)	5.04 (128)	4.61 (117)	1275 (579)
LHYM3-4F18DBY-EP	3 x 4 (2.2 x 4)	46.23 (1174)	7.24 (184)	6.71 (170)	4.53 (115)	1275 (578)	49.31 (1252)	7.24 (184)	6.71 (170)	7.60 (193)	5.43 (138)	5.04 (128)	1291 (586)
LHYM5-4F18DBY-EP	5 x 4 (3.7 x 4)	47.49 (1206)	8.74 (222)	7.34 (186)	4.65 (118)	1299 (589)	51.06 (1297)	8.74 (222)	7.34 (186)	8.21 (209)	6.02 (153)	6.30 (160)	1323 (600)
LHYM8-4F18DBY-EP	7.5 x 4 (5.5 x 4)	49.19 (1249)	8.74 (222)	7.34 (186)	4.65 (118)	1333 (605)	52.75 (1340)	8.74 (222)	7.34 (186)	8.21 (209)	6.02 (153)	6.30 (160)	1357 (616)
LHYM10-4F18DBY-EP	10 x 4 (7.5 x 4)	50.68 (1287)	10.24 (260)	9.04 (230)	5.43 (138)	1360 (617)	54.82 (1392)	10.24 (260)	9.04 (230)	9.57 (243)	7.44 (189)	7.32 (186)	1404 (637)
LHYM03-4F19DAY-AV	1/3 x 4 (0.25 x 4)	42.68 (1084)	ø4.88 (ø124)	4.63 (118)	2.32 (59)	1314 (596)	43.94 (1116)	ø4.88 (ø124)	4.63 (118)	3.58 (91)	2.40 (61)	-	1317 (597)
LHYM05-4F19DAY	1/2 x 4 (0.4 x 4)	42.68 (1084)	ø4.88 (ø124)	4.63 (118)	2.32 (59)	1314 (596)	43.94 (1116)	ø4.88 (ø124)	4.63 (118)	3.58 (91)	2.40 (61)	-	1317 (597)
LHYM05-4F19DAY-AV	1/2 x 4 (0.4 x 4)	44.09 (1120)	ø5.94 (ø151)	5.67 (144)	3.82 (97)	1321 (599)	45.79 (1163)	ø5.94 (ø151)	5.67 (144)	5.51 (140)	3.66 (93)	3.94 (100)	1326 (602)
LHYM08-4F19DAY	3/4 x 4 (0.55 x 4)	44.09 (1120)	ø5.94 (ø151)	5.67 (144)	3.82 (97)	1318 (598)	45.79 (1163)	ø5.94 (ø151)	5.67 (144)	5.51 (140)	3.66 (93)	3.94 (100)	1324 (601)
LHYM08-4F19DAY-AV	3/4 x 4 (0.55 x 4)	45.39 (1153)	ø6.30 (ø160)	5.86 (149)	3.94 (100)	1326 (602)	47.83 (1215)	ø6.30 (ø160)	5.86 (149)	6.38 (162)	4.53 (115)	4.29 (109)	1337 (607)
LHYM1-4F19DAY-EP	1 x 4 (0.75 x 4)	45.83 (1164)	6.22 (158)	5.98 (152)	3.82 (97)	1331 (604)	48.33 (1228)	6.22 (158)	5.98 (152)	6.32 (161)	4.80 (122)	4.25 (108)	1341 (609)
LHYM1H-4F19DAY-EP	1.5 x 4 (1.1 x 4)	46.89 (1191)	6.57 (167)	6.16 (156)	3.82 (97)	1338 (607)	49.63 (1261)	6.57 (167)	6.16 (156)	6.56 (167)	5.04 (128)	4.61 (117)	1350 (613)
LHYM2-4F19DAY-EP	2 x 4 (1.5 x 4)	46.89 (1191)	6.57 (167)	6.16 (156)	3.82 (97)	1341 (609)	49.63 (1261)	6.57 (167)	6.16 (156)	6.56 (167)	5.04 (128)	4.61 (117)	1353 (614)
LHYM3-4F19DAY-EP	3 x 4 (2.2 x 4)	46.30 (1176)	7.24 (184)	6.71 (170)	4.53 (115)	1354 (615)	49.37 (1254)	7.24 (184)	6.71 (170)	7.60 (193)	5.43 (138)	5.04 (128)	1371 (622)

Notes [1]: DM Dimension Symbol ø = Round Fan Cover  
DM Dimension Symbol = Square Fan Cover

LXXX-4XX0/4XX5 Frame sizes have equal dimensions, different ratings.

# Dimensions

## LHYM05-4F19DAY-AV ▶ LHYM10-4F19DBY-EP

### Double Reduction Cyclo® LHYM-4F19DAY ~ 4F19DBY

Minimum Engagement		
Frame Size	TT	
	inch	(mm)
4F	16.2	(412)

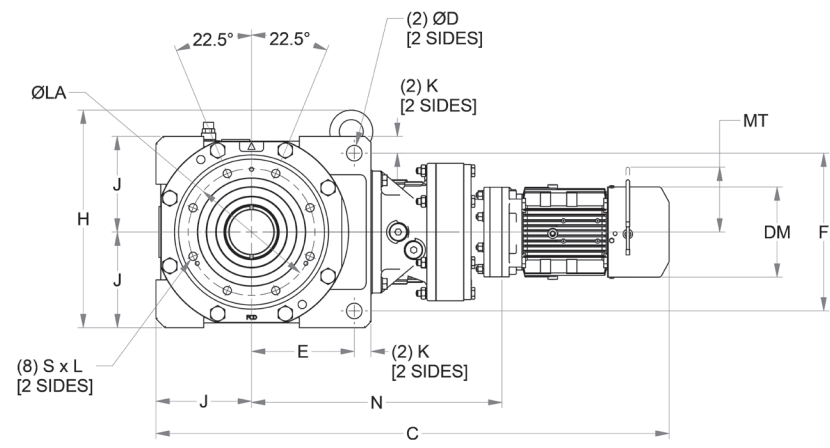
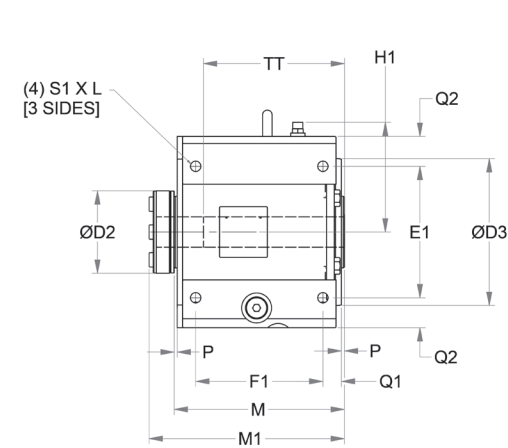
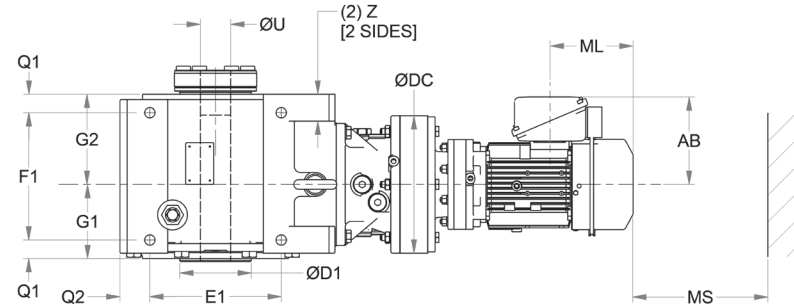

All dimensions are in inches (mm)

Model	4 Pole Motor HP (kW)	Without Brake					With Brake						
		C	DM <sup>[1]</sup>	AB	ML	Weight lb (kg)	C	DM <sup>[1]</sup>	AB	ML	MS	MT	Weight lb (kg)
LHYM5-4F19DAY-EP	5 x 4 (3.7 x 4)	47.76 (1213)	8.74 ( 222)	7.34 (186)	4.65 (118)	1380 (626)	51.32 (1304)	8.74 ( 222)	7.34 (186)	8.21 (209)	6.02 (153)	6.30 (160)	1404 (637)
LHYM8-4F19DAY-EP	7.5 x 4 (5.5 x 4)	49.45 (1256)	8.74 ( 222)	7.34 (186)	4.65 (118)	1413 (641)	53.01 (1347)	8.74 ( 222)	7.34 (186)	8.21 (209)	6.02 (153)	6.30 (160)	1437 (652)
LHYM3-4F19DBY-EP	3 x 4 (2.2 x 4)	46.93 (1192)	7.24 ( 184)	6.71 (170)	4.53 (115)	1358 (616)	50.00 (1270)	7.24 ( 184)	6.71 (170)	7.60 (193)	5.43 (138)	5.04 (128)	1375 (624)
LHYM5-4F19DBY-EP	5 x 4 (3.7 x 4)	48.19 (1224)	8.74 ( 222)	7.34 (186)	4.65 (118)	1383 (627)	51.75 (1315)	8.74 ( 222)	7.34 (186)	8.21 (209)	6.02 (153)	6.30 (160)	1406 (638)
LHYM8-4F19DBY-EP	7.5 x 4 (5.5 x 4)	49.88 (1267)	8.74 ( 222)	7.34 (186)	4.65 (118)	1417 (643)	53.44 (1358)	8.74 ( 222)	7.34 (186)	8.21 (209)	6.02 (153)	6.30 (160)	1441 (654)
LHYM10-4F19DBY-EP	10 x 4 (7.5 x 4)	51.38 (1305)	10.24 ( 260)	9.04 (230)	5.43 (138)	1444 (655)	55.51 (1410)	10.24 ( 260)	9.04 (230)	9.57 (243)	7.44 (189)	7.32 (186)	1488 (675)

All dimensions are in inches (mm).

Model	N	ØDC	J	E	F	K	Z	ØD	E1	F1	Q1	Q2	S1 x L	M
4F19DA	28.3 (718)	16.9 (430)	9.45 (240)	9.92 (252)	15.8 (400)	1.6 (40)	2.2 (55)	1.5 (39)	13.4 (340)	12.6 (320)	1.99 (50.5)	2.8 (70)	M30 x 1.97 (M30 x 50)	17.1 (435)
4F19DB	28.9 (734)	16.9 (430)												

Model	P	G1	G2	H	H1	ØLA	ØD3	S x L	M1	ØD1	ØD2	ØU	
												Std & Max	Min
4F19DA, 4F19DB	0.3 (7)	7.20 (183)	9.37 (238)	23.2 (590)	10.8 (273)	12.6 (320)	14.6 (370)	M24 x 1.97 (M24 x 50)	19.1 (486)	7.09 (180)	8.15 (207)	4-15/16 (125.41)	3-15/16 (100.01)

Notes [1]: DM Dimension Symbol ø = Round Fan Cover  
DM Dimension Symbol = Square Fan Cover

LXXX-4XX0/4XX5 Frame sizes have equal dimensions, different ratings.



# Dimensions

## Double Reduction Cyclo®, Y2 Mounting External Lubricant Piping LHY(J)-4A10DA ~ 4F19DB

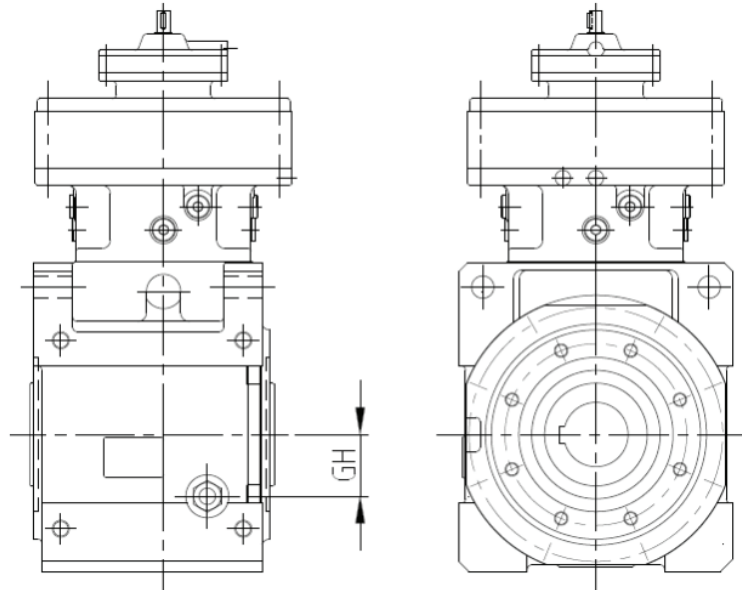

Cyclo® BBB4

All dimensions are in inches (*mm*).

Frame Size	GH
4A	46 (1.81)
4B	60 (2.36)
4C	72 (2.83)
4D	97 (3.82)
4E	111 (4.37)
4F	120 (4.72)

Dimensions

# 3

# Options

---

Cyclo® BBB4

Options

## Keyed Hollow Shaft

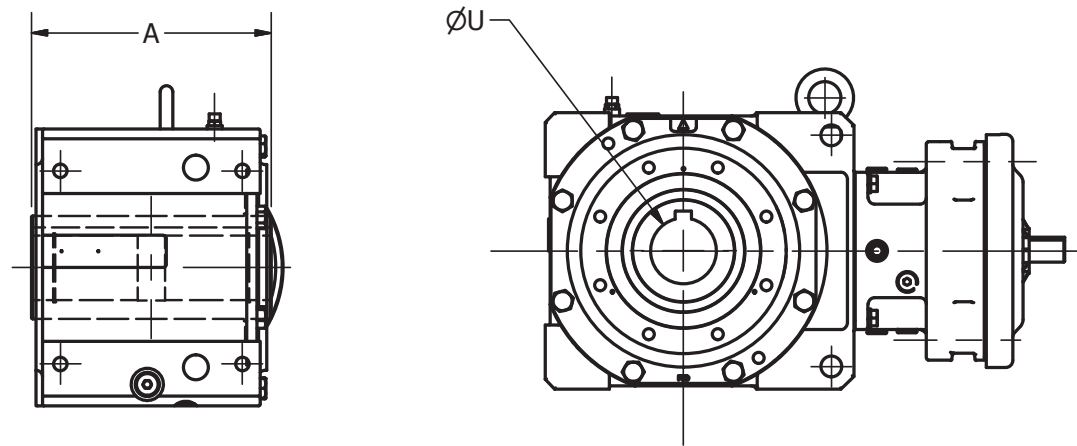

All dimensions are in inches (mm).

Frame Size	Standard Inch Bore Dimension			Standard Metric Bore Dimension			A	TK*
	ØU	ØU Tolerance	Keyway	ØU	ØU Tolerance	Keyway		
4A	2.000	+0.0018/+0.0006	1/2 x 1/4	(55)	(+0.046/+0.016)	(16 x 10)	8.50 (216)	6.50 (165)
4B	2.375	+0.0018/+0.0006	5/8 x 5/16	(65)	(+0.046/+0.016)	(18 x 11)	10.20 (259)	7.87 (200)
4C	2.750	+0.0018/+0.0006	5/8 x 5/16	(75)	(+0.046/+0.016)	(20 x 12)	11.22 (285)	9.76 (248)
4D	3.250	+0.0021/+0.0007	3/4 x 3/8	(85)	(+0.054/+0.019)	(22 x 14)	13.39 (340)	11.93 (303)
4E	4.000	+0.0021/+0.0007	1 X 1/2	(100)	(+0.054/+0.019)	(28 x 16)	14.69 (373)	10.24 (260)
4F	4.500	+0.0023/+0.0009	1 X 1/2	(120)	(+0.058/+0.023)	(32 x 18)	17.13 (435)	12.44 (316)

\*Recommended minimum shaft engagement

## Key Hollow Bore

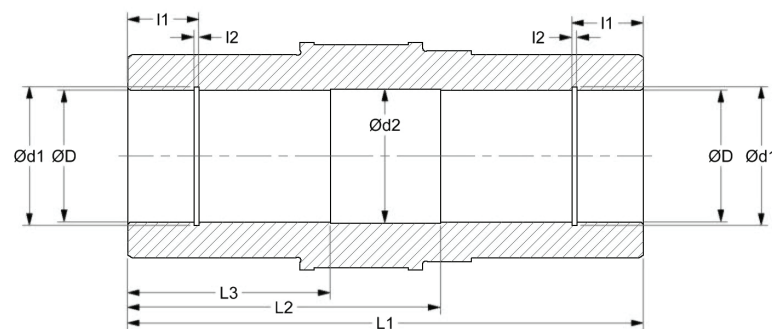

All dimensions are in inches (mm).

Frame Size	BBB		Retaining Ring Groove				Relief	
	ØD	L1	Ød1	I1	I2	Ød2	L2	L3
4A	2 (55)	8.50 (216)	2.09 (58)	1.18 (30)	.069 (2.2)	2.04 (56)	5.16 (131)	3.35 (85)
4B	2-3/8 (65)	10.2 (259)	2.51 (68)	1.18 (30)	0.085 (2.7)	2.42 (66)	6.26 (159)	3.94 (100)
4C	2-3/4 (75)	11.2 (285)	2.93 (78)	1.18 (30)	0.100 (2.7)	2.80 (76)	6.50 (165)	4.72 (120)
4D	3-1/4 (85)	13.4 (340)	3.43 (88.5)	1.46 (37)	0.116 (3.2)	3.31 (86)	7.68 (208)	5.71 (165)
4E	4 (100)	14.7 (373)	4.27 (103.5)	1.46 (37)	0.116 (3.2)	4.06 (101)	8.19 (208)	6.50 (165)
4F	4-1/2 (120)	17.1 (435)	4.74 (124)	1.93 (49)	0.120 (4.2)	4.55 (121)	9.49 or 9.69 (3) (241 or 246 (3))	7.44 or 7.64 (3) (189 or 194 (3))

## Solid Output Shaft

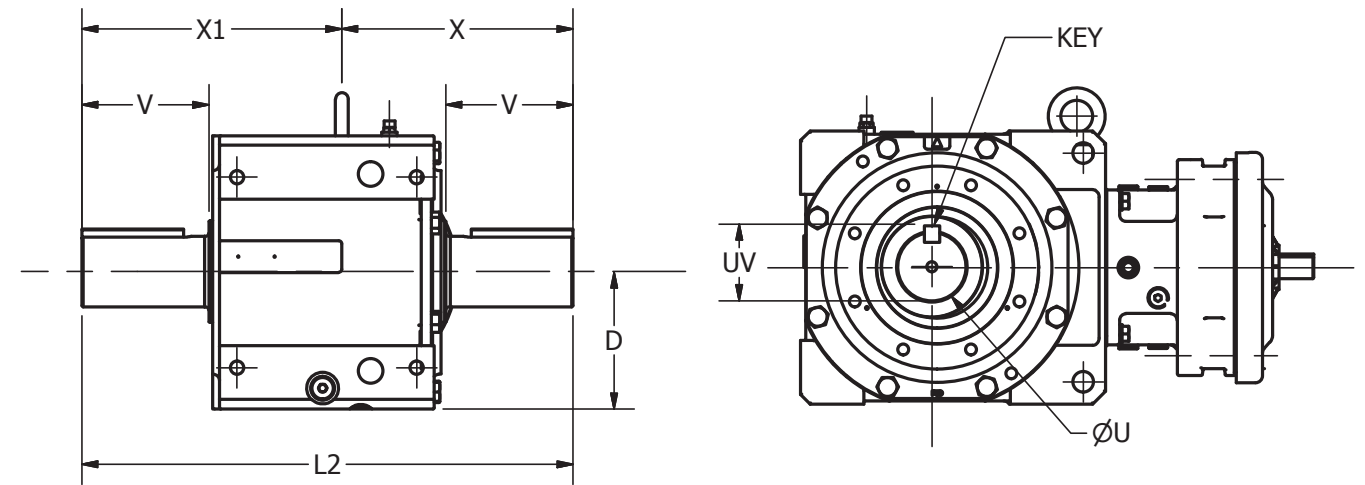

All dimensions are in inches (mm).

Frame Size	Standard Inch Shaft Dimension				Standard Metric Shaft Dimensions				D	V	X	X1	L2
	ØU	ØU Tolerance	UV	Key	ØU	ØU Tolerance	UV	Key					
4A	2.000	h6: 0/-0.0006	2.22	1/2 x 1/2 x 2.76	(50)	(h6: 0/-0.016)	(53.5)	(14 x 9 x 70)	4.33 (110)	3.54 (90)	7.48 (190)	8.11 (206)	15.59 (396)
4B	2.875	h6: 0/-0.0007	3.20	3/4 x 3/4 x 3.15	(65)	(h6: 0/-0.019)	(69.0)	(18 x 11 x 80)	5.12 (130)	4.53 (115)	9.53 (242)	9.72 (247)	19.25 (489)
4C	3.125	h6: 0/-0.0007	3.45	3/4 x 3/4 x 4.72	(80)	(h6: 0/-0.019)	(85.0)	(22 x 14 x 120)	6.30 (160)	5.71 (145)	10.79 (274)	11.85 (301)	22.64 (575)
4D	3.625	h6 0/-0.0009	4.01	7/8 x 7/8 x 5.51	(95)	(h6: 0/-0.022)	(100)	(25 x 14 x 140)	7.48 (190)	6.69 (170)	12.80 (325)	13.98 (355)	26.77 (680)
4E	4.375	h6 0/-0.0009	4.82	1 x 1 x 6.30	(110)	(h6: 0/-0.022)	(116)	(28 x 16 x 160)	8.46 (215)	7.87 (200)	14.29 (363)	16.14 (410)	30.43 (773)
4F	4.750	h6 0/-0.0010	5.29	1-1/4 x 1-1/4 x 6.69	(130)	(h6: 0/-0.025)	(137)	(32 x 18 x 170)	9.45 (240)	8.27 (210)	15.75 (400)	17.91 (455)	33.66 (855)

## Output Flange

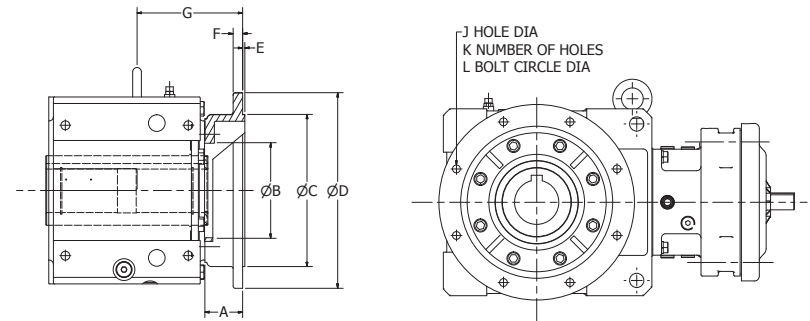

All dimensions are in inches (mm).

Frame Size	A	ØB	ØC	ØD	E	F	G	J	K	L
<b>4A</b>	2.36 (60)	4.72 (120)	7.09 (180)	9.84 (250)	0.16 (4)	0.59 (15)	6.30 (160)	0.55 (14)	4	8.46 (215)
<b>4B</b>	2.40 (61)	5.51 (140)	9.06 (230)	11.8 (300)	0.16 (4)	0.63 (16)	7.40 (188)	0.55 (14)	4	10.4 (265)
<b>4C</b>	2.87 (73)	6.50 (165)	9.84 (250)	13.8 (350)	0.20 (5)	0.71 (18)	7.95 (202)	0.71 (18)	4	11.8 (300)
<b>4D</b>	3.15 (80)	7.68 (195)	13.8 (350)	17.7 (450)	0.20 (5)	0.87 (22)	9.25 (235)	0.71 (18)	8	15.8 (400)
<b>4E</b>	3.15 (80)	8.66 (220)	13.8 (350)	17.7 (450)	0.20 (5)	0.87 (22)	9.57 (243)	0.71 (18)	8	15.8 (400)
<b>4F</b>	2.56 (65)	9.45 (240)	21.7 (550)	26.0 (660)	0.20 (5)	0.94 (24)	10.0 (255)	0.87 (22)	8	23.6 (600)

## Foot Mounted

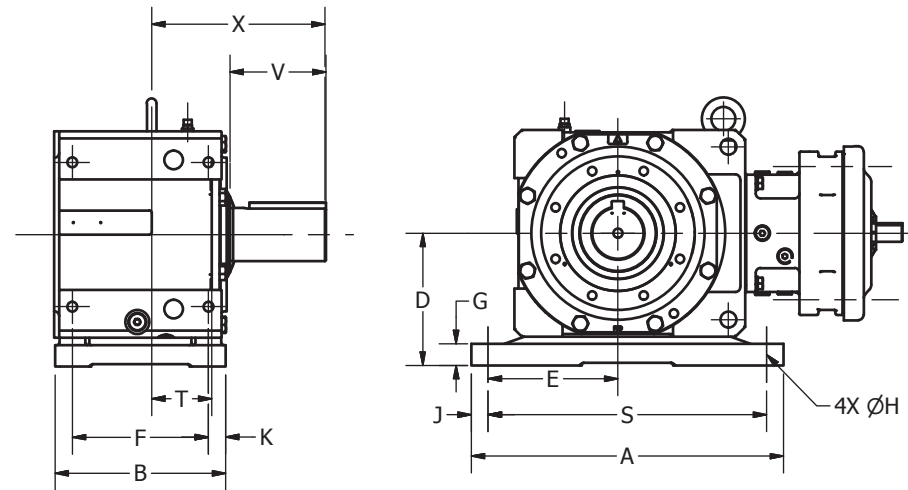

All dimensions are in inches (mm).

Frame Size	A	B	D	E	F	G	ØH	J	K	S	T	V	X
<b>4A</b>	12.6 (320)	7.95 (202)	5.51 (140)	5.31 (135)	6.30 (160)	0.98 (25)	0.55 (14)	0.79 (20)	0.83 (21)	11.0 (280)	2.83 (72)	3.54 (90)	7.48 (190)
<b>4B</b>	15.2 (385)	9.65 (245)	6.69 (170)	6.30 (160)	7.68 (195)	1.38 (35)	0.71 (18)	0.79 (20)	0.98 (25)	13.6 (345)	3.74 (95)	4.53 (115)	9.53 (242)
<b>4C</b>	19.9 (505)	10.6 (270)	8.27 (210)	7.68 (195)	8.27 (210)	1.57 (40)	0.87 (22)	1.18 (30)	1.18 (30)	17.5 (445)	3.58 (91)	5.71 (145)	10.8 (274)
<b>4D</b>	22.1 (560)	12.6 (320)	9.65 (245)	9.25 (235)	10.2 (260)	1.77 (45)	1.02 (26)	1.18 (30)	1.18 (30)	19.7 (500)	4.53 (115)	6.69 (170)	12.8 (325)
<b>4E</b>	25.6 (650)	14.0 (355)	10.8 (275)	10.6 (270)	11.0 (280)	1.77 (45)	1.30 (33)	1.38 (35)	1.50 (38)	22.8 (580)	4.57 (116)	7.87 (200)	14.3 (363)
<b>4F</b>	29.1 (740)	15.8 (400)	12.6 (320)	11.8 (300)	12.6 (320)	2.56 (65)	1.30 (33)	1.38 (35)	1.57 (40)	26.4 (670)	4.43 (113)	8.27 (210)	15.8 (400)

## Shrink Disc

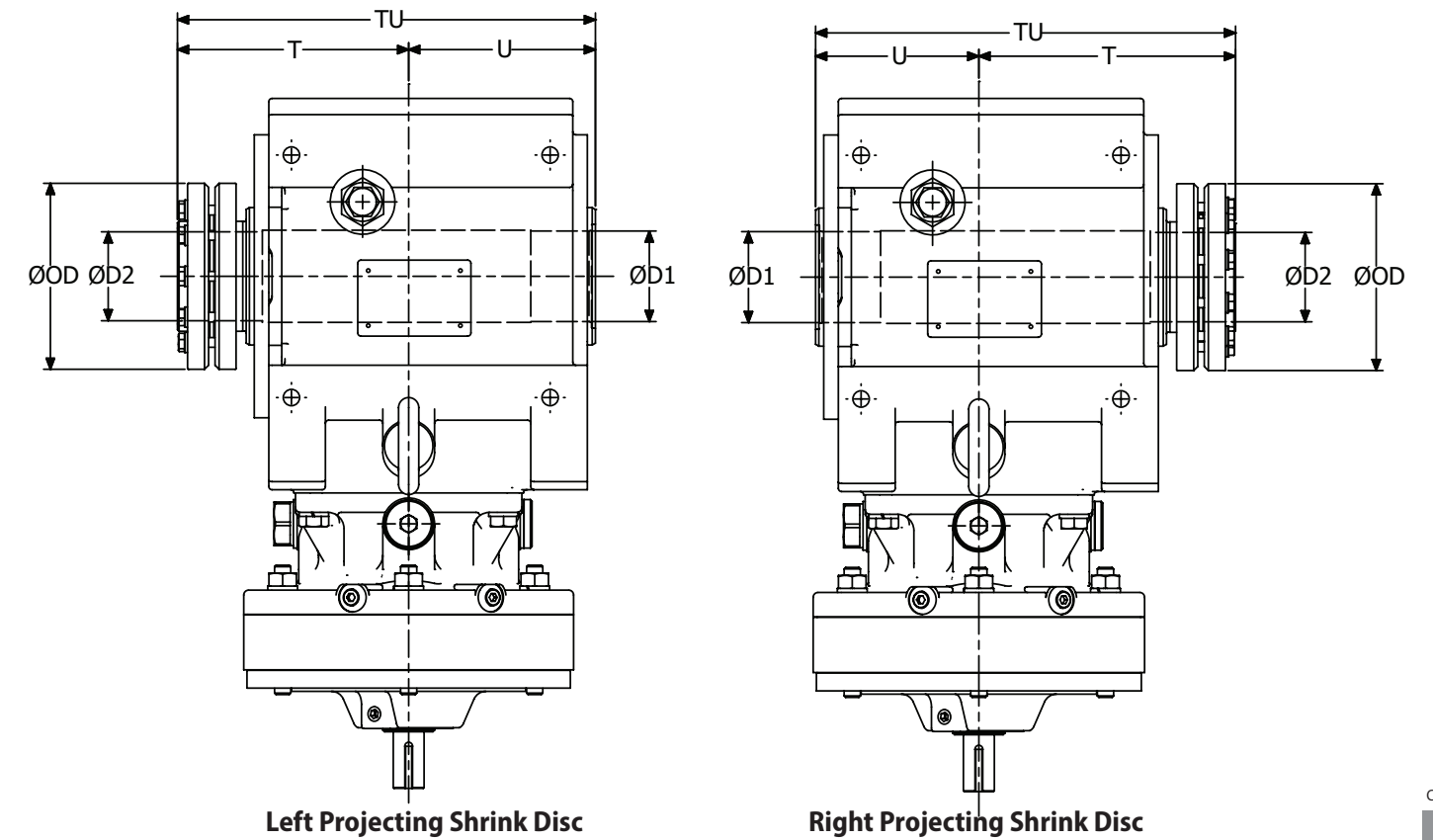

All dimensions are in inches (mm).

Frame Size	ØD1	ØD2	ØOD	TU	Left Projecting Shrink Disc		Right Projecting Shrink Disc	
					T	U	T	U
<b>4A</b>	2.20 (56)	2.17 (55)	4.53 (115)	10.2 (259)	5.28 (134)	4.90 (125)	6.40 (163)	3.78 (96)
<b>4B</b>	2.60 (66)	2.56 (65)	5.71 (145)	12.0 (304)	6.76 (172)	5.19 (132)	6.95 (177)	5.00 (127)
<b>4C</b>	2.99 (76)	2.95 (75)	6.69 (170)	13.3 (337)	7.11 (181)	6.14 (156)	8.17 (208)	5.08 (129)
<b>4D</b>	3.39 (86)	3.35 (85)	7.28 (185)	16.0 (408)	8.76 (223)	7.28 (185)	9.94 (253)	6.10 (155)
<b>4E</b>	3.98 (101)	3.94 (100)	9.06 (230)	17.3 (441)	9.07 (231)	8.27 (210)	10.9 (278)	6.42 (163)
<b>4F</b>	4.76 (121)	4.72 (120)	11.4 (290)	20.2 (513)	10.6 (268)	9.65 (245)	12.7 (323)	7.48 (190)



## Shrink Disc - Recommended Driven Inch Shaft Dimensions

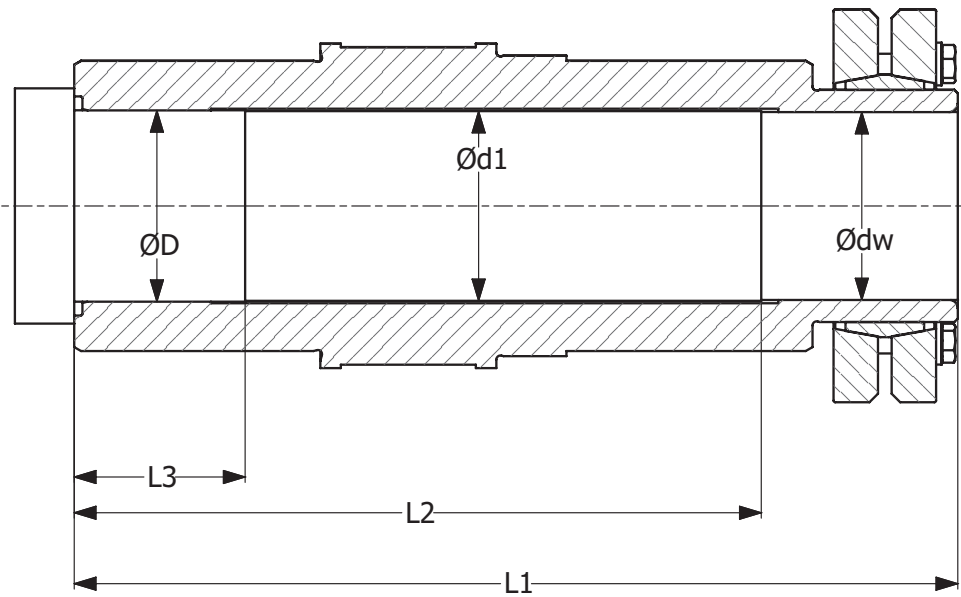

Recommendations for the design of the driven shaft if Shrink Disc connection method is selected:

- When ordering the Cyclo® BBB4 with a shrink disc output option, be sure to designate the orientation (left or right) in which to install the shrink disc.
- Once the product is shipped from the Sumitomo factory, the orientation of the shrink disc **cannot** be changed in the field.
- When designing the driven shaft to be inserted into the shrink disc, refer to the table below for shaft design recommendations.

All dimensions are in inches.

Model	Driven Shaft Recommended Dimensions							
	Ødw	Ødw tolerance	Ød1	ØD	ØD tolerance	L1	L2	L3
4A100, 4A105 4A110, 4A115 4A120, 4A125 4A140, 4A145	1-15/16 2 2-3/16	h6: +0/-0.0006 h6: +0/-0.0007 h6: +0/-0.0007	1.91 1.98 2.19	1.98 2.04 2.22	h7: +0/-0.0010 h7: +0/-0.0012 h7: +0/-0.0012	10.18	7.91	1.97
4B120, 4B125 4B140, 4B145 4B160, 4B165	2 2-3/16 2-3/8 2-7/16	h6: +0/-0.0007	1.98 2.19 2.39 2.46	2.04 2.22 2.41 2.48	h7: +0/-0.0012	11.95	9.60	1.97
4C140, 4C145 4C160, 4C165 4C170, 4C175	2-3/4 2-15/16	h6: +0/-0.0007	2.77 2.97	2.79 2.99	h7: +0/-0.0012	13.25	10.63	1.97

## Shrink Disc - Recommended Driven Metric Shaft Dimensions

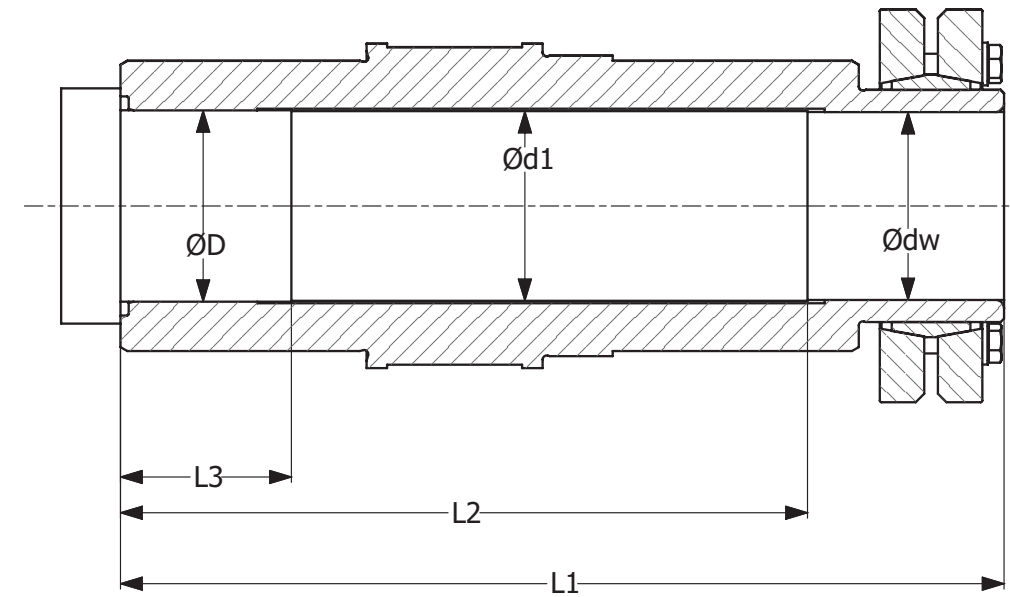

All dimensions are in mm.

Model	Driven Shaft Recommended Dimensions							
	Ødw	Ødw tolerance	Ød1	ØD	ØD tolerance	L1	L2	L3
4A100, 4A105 4A110, 4A115	55.00	h6: +0/-0.019	55.50	56.00	h7: +0/-0.030	258.50	201.00	50.00
4B120, 4B125 4B140, 4B145	65.00	h6: +0/-0.019	65.50	66.00	h7: +0/-0.030	303.50	244.00	50.00
4C160, 4C165 4C170, 4C175	75.00	h6: +0/-0.019	75.50	76.00	h7: +0/-0.030	336.50	270.00	50.00
4D170, 4D175 4D180, 4D185	85.00	h6: +0/-0.022	85.50	86.00	h7: +0/-0.035	407.50	325.00	65.00
4E180, 4E185 4E190, 4E195	100.00	h6: +0/-0.022	100.50	101.00	h7: +0/-0.035	440.50	358.00	65.00
4F180, 4F185 4F190, 4F195	120.00	h6: +0/-0.022	120.50	121.00	h7: +0/-0.035	513.00	415.00	98.00

## Torque Arm Turnbuckle Type<sup>[1]</sup>

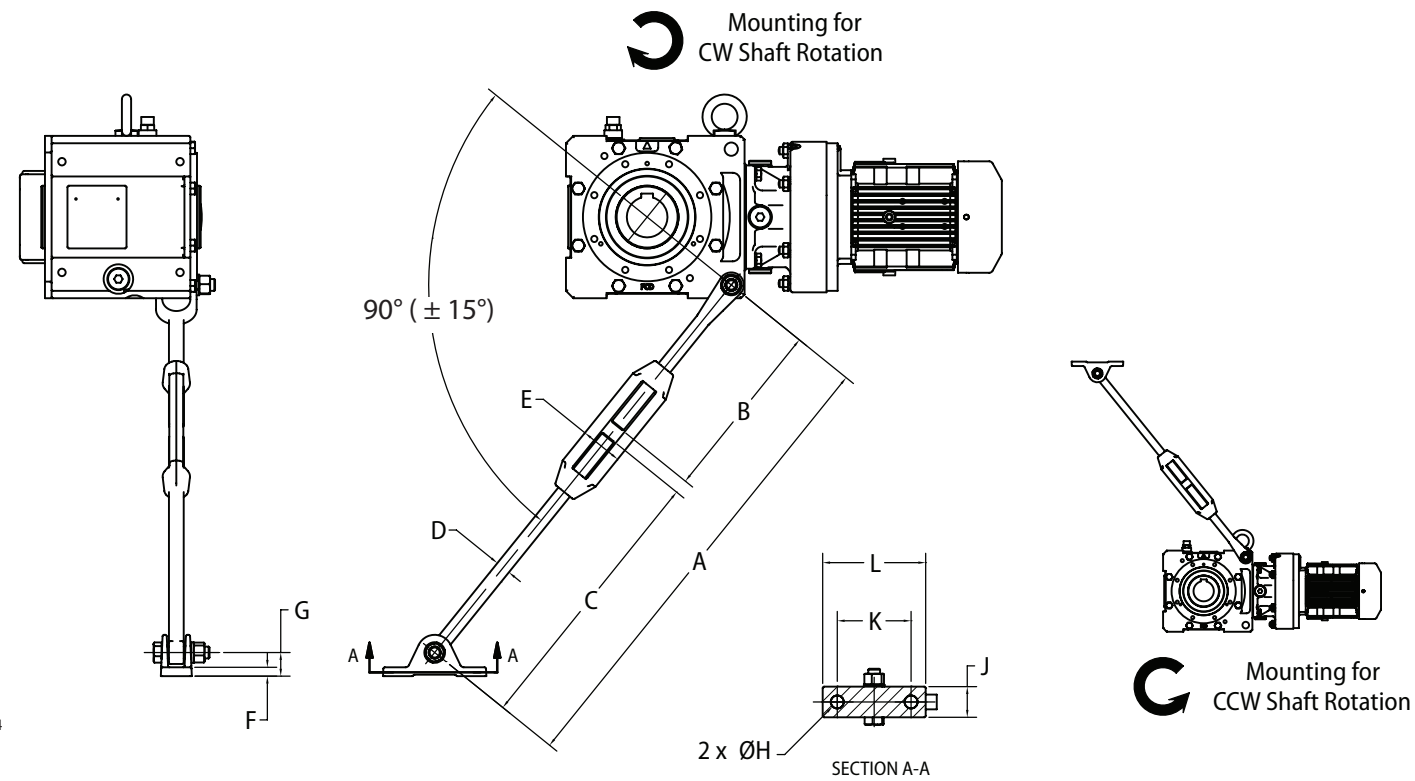

All dimensions are in inches (mm).

Frame Size	A		B	C	D Thread	E	F	G	ØH	J	K	L
	Min	Max										
4A	25.2 (640)	28.7 (730)	9.69 (246)	14.8 (375)	M20	2.24 (57)	0.47 (12.0)	1.26 (32)	0.69 (17.5)	1.65 (42)	3.94 (100)	5.51 (140)
4B	26.0 (660)	29.5 (750)	10.4 (263)	14.8 (375)	M24	2.32 (59)	0.81 (20.5)	2.13 (54)	0.69 (17.5)	2.76 (70)	4.76 (121)	6.61 (168)
4C	26.0 (660)	29.5 (750)	10.4 (263)	14.8 (375)	M24	2.32 (59)	0.81 (20.5)	2.13 (54)	0.69 (17.5)	2.76 (70)	4.76 (121)	6.61 (168)
4D, 4E	33.9 (860)	37.4 (950)	18.3 <sup>[2]</sup> (465) <sup>[2]</sup>	14.8 (375)	M24	2.32 (59)	0.81 (20.5)	2.13 (54)	0.69 (17.5)	2.76 (70)	4.76 (121)	6.61 (168)

**Note:** [1] The Cyclo® BBB4 is shown in Y1 mounting position; use two turnbuckle torque arms if application requires shaft rotation in both directions and use torque arm in tension, not compression. Consult Operation and Maintenance Manual or the Factory when mounting in positions other than Y1.  
 [2] Value may vary from shown.  
 [3] Turnbuckle Type torque arm is not available for size F Cyclo(R) BBB4 units. Consult Factory for F-size torque arm type and dimensions.

## Torque Arm T-Type<sup>[1]</sup>

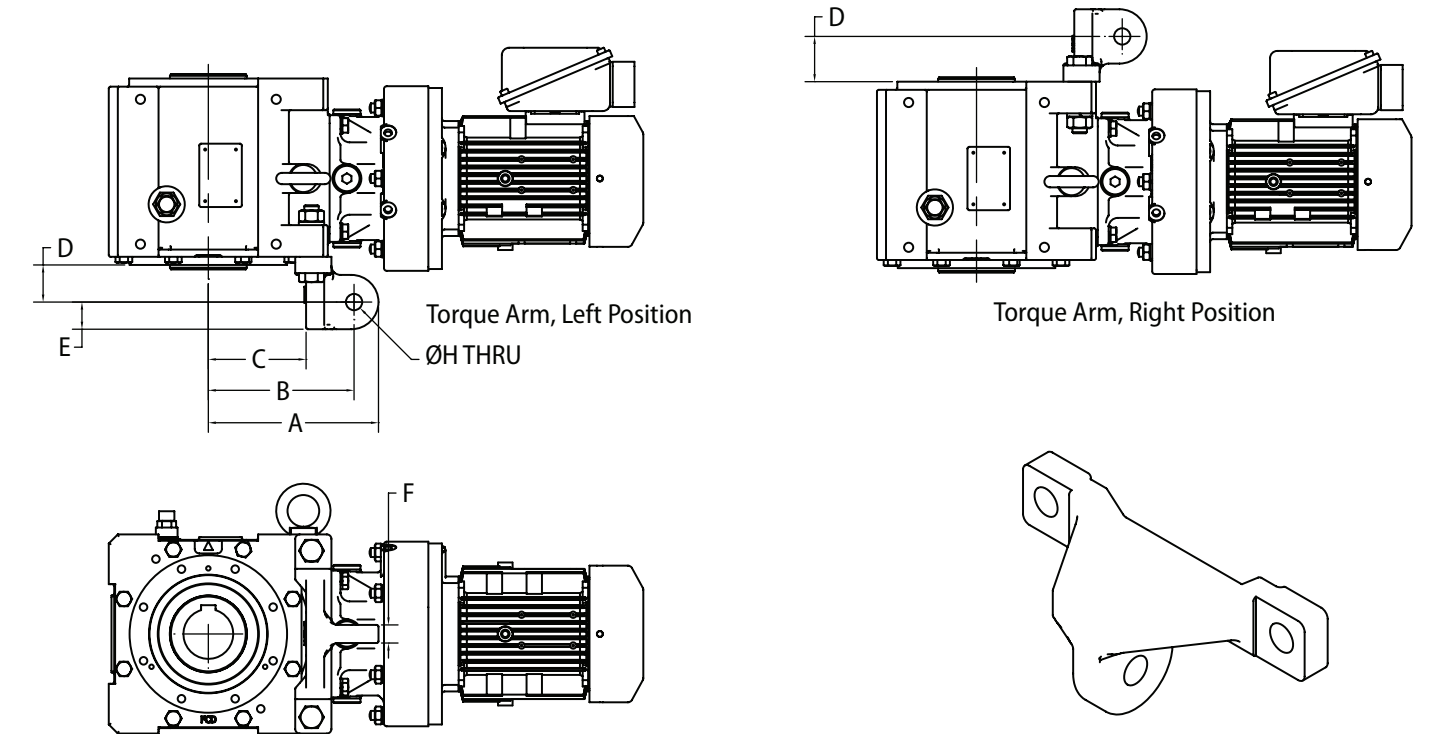

All dimensions are in inches (mm).

Frame Size	A		B	C	D		E	F	ØH
	Min	Max			Left <sup>[2]</sup>	Right <sup>[2]</sup>			
4A	7.40 (188)	28.7 (730)	6.34 (161)	4.25 (108)	1.61 (41)	1.97 (50)	1.18 (30)	0.79 (20)	0.71 (18)
4B	8.98 (228)	29.5 (750)	7.68 (195)	5.00 (127)	2.09 (53)	2.44 (62)	1.42 (36)	1.13 (29)	0.87 (22)
4C	10.8 (274)	29.5 (750)	9.13 (232)	6.14 (156)	2.60 (66)	2.95 (75)	1.77 (45)	1.25 (32)	1.02 (26)
4D	12.9 (327)	37.4 (950)	11.0 (279)	7.40 (188)	3.19 (81)	3.58 (91)	2.17 (55)	1.50 (38)	1.30 (33)
4E	14.2 (361)	37.4 (950)	12.1 (306)	8.27 (210)	3.17 (81)	3.58 (91)	2.17 (55)	1.42 (36)	1.30 (33)

**Note:** [1] The Cyclo® BBB4 is shown in Y1 mounting position  
 [2] D dimension is from flange-mount casing surface to hole ØH.  
 [3] Turnbuckle Type torque arm is not available for size F Cyclo(R) BBB4 units. Consult Factory for F-size torque arm type and dimensions.

## Screw Conveyor Drive

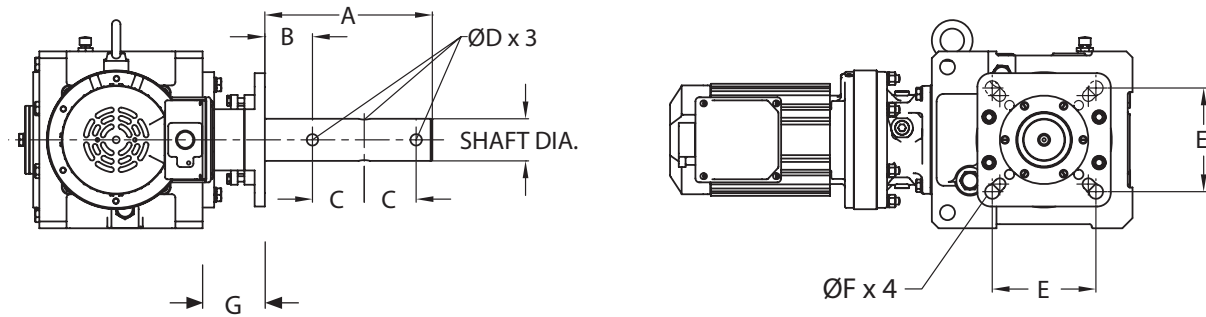

- The Screw Conveyor option design conforms to established CEMA inch dimensions.
- Complete Cyclo® BBB screw conveyor drive consists of reducer, CEMA drive shaft assembly and mounting adapter kit.
- CEMA drive shafts are three hole style. Two hole drives available on request.

All dimensions are in inches.

Model	Shaft Diameter	To Fit Screw Diameter	A	B	C	ØD	E	ØF
4A, 4B	1-1/2	6 to 9	9.00	2.13	3.00	17/32	4.00	0.531
	2	9 to 12	9.00	2.13	3.00	21/32	0.38	0.669
	2-7/16	12 to 14	9.69	2.75	3.00	21/32	5.63	0.669
	3	12 to 20	9.88	2.88	3.00	25/32	6.00	0.827
4C, 4D	2	9 to 12	9.00	2.13	3.00	21/32	5.13	0.669
	2-7/16	12 to 14	9.69	2.75	3.00	21/32	5.63	0.669
	3	12 to 20	9.88	2.88	3.00	25/32	6.00	0.827
	3-7/16	18 to 24	13.10	3.88	4.00	29/32	6.75	0.827
4E	2-7/16	12 to 14	9.69	2.75	3.00	21/32	5.63	0.669
	3	12 to 20	9.88	2.88	3.00	25/32	6.00	0.827
	3-7/16	18 to 24	13.10	3.88	4.00	29/32	6.75	0.827

Model	G	
	Cast Iron Adapter	Fabricated Steel Adapter
A	4.17	3.60
B	3.96	3.60
C	4.31	3.92
D	4.65	4.25
E	5.93	5.49

### Shaft Option 1: Standard 'Taper Grip Hub' 3-Hole Screw Conveyor Steel Shafts

Model	Drive Shaft Diameters & CEMA Drive Shaft Assembly Part Number					Adapter Kit	
	Ø 1-1/2"	Ø 2"	Ø 2-7/16"	Ø 3"	Ø 3-7/16"	Cast Iron Option	Fabricated steel Option
4A	116E4108-C3	116E4200-C3	116E4207-C3	116E4300-C3	-	118A4050	118A4040
4B	116F4108-C3	116F4200-C3	116F4207-C3	116F4300-C3	-	118B4050	118B4040
4C	-	116G4200-C3	116G4207-C3	116G4300-C3	116G4307-C3	118C4050	118C4040
4D	-	116H4200-C3	116H4207-C3	116H4300-C3	116H4307-C3	118D4050	118D4040
4E	-	-	116J4207-C3	116J4300-C3	116J4307-C3	118E4050	118E4040

### Shaft Option 2: Standard 'Keyed' 3-Hole Screw Conveyor Shafts [Steel and Stainless steel options]

Model	Drive Shaft Diameters & CEMA Drive Shaft Assembly Part Number <sup>[1]</sup>					Adapter Kit	
	Ø 1-1/2"	Ø 2"	Ø 2-7/16"	Ø 3"	Ø 3-7/16"	Cast Iron Option	Fabricated steel Option
4A	118A5108-C3/ S3	118A5200-C3/ S3	118A5207-C3/ S3	118A5300-C3/ S3	-	118A4060	118A4040
4B	118B5108-C3/ S3	118B5200-C3/ S3	118B5207-C3/ S3	118B5300-C3/ S3	-	118B4060	118B4040
4C	-	118C5200-C3/ S3	118C5207-C3/ S3	118C5300-C3/ S3	118C5307-C3/ S3	118C4060	118C4040
4D	-	118D5200-C3/ S3	118D5207-C3/ S3	118D5300-C3/ S3	118D5307-C3/ S3	-	118D4040
4E	-	-	118E5207-C3/ S3	118E5300-C3/ S3	118E5307-C3/ S3	-	118E4040

Note: [1] The dimension shown is E maximum.

[2] Use suffix 'C3' for Carbon Steel, or 'S3' for Stainless Steel (AISI316) shaft material

## Clear Oil Fill Cup

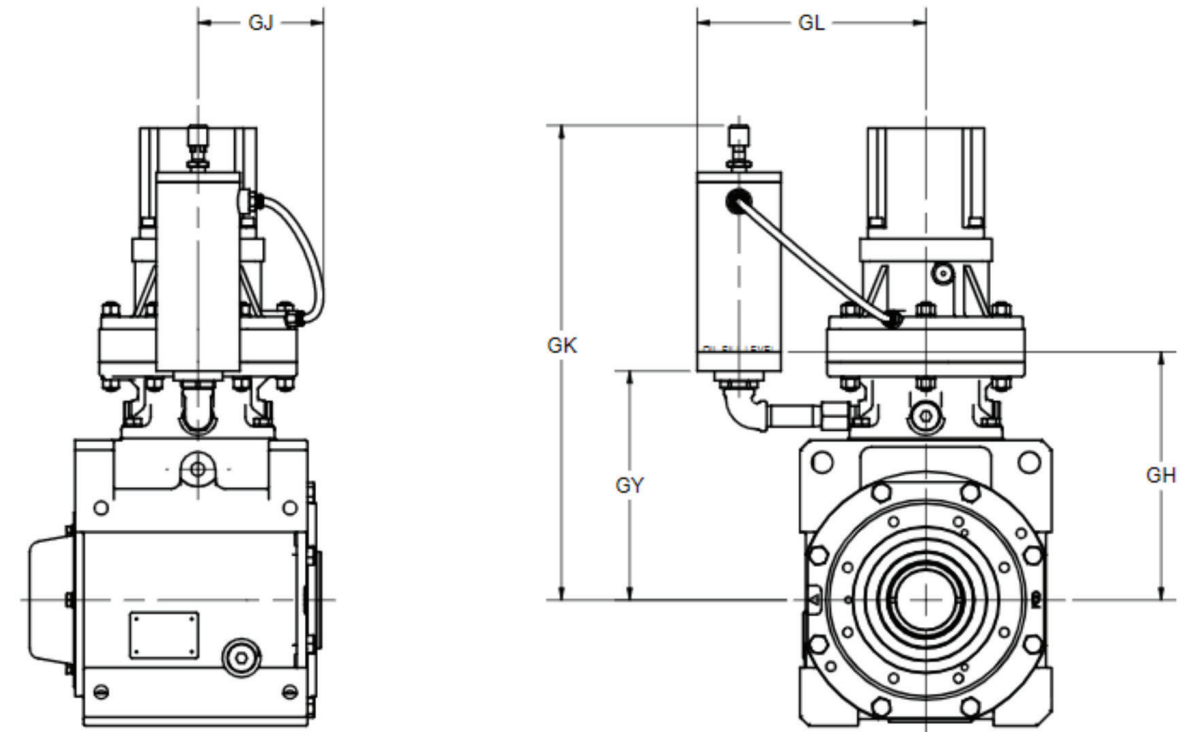

Frame Size	GH	GL	GK	GY	GJ
4A100/5	8.66 (220)	9.09 (231)	18.73 (476)	8.66 (220)	3.78 (96)
4A110/5	8.98 (228)	10.18 (259)	18.74 (476)	8.67 (220)	4.02 (102)
4A120/5	8.90 (226)	9.96 (253)	18.55 (471)	8.47 (215)	5.28 (134)
4A140/5	9.61 (244)	11.89 (302)	18.61 (473)	8.54 (217)	5.28 (134)
4B120/5	10.35 (263)	9.96 (253)	19.99 (508)	9.92 (252)	5.28 (134)
4B140/5	10.87 (276)	11.89 (302)	19.89 (505)	9.82 (250)	5.28 (134)
4B160/5	11.54 (293)	12.79 (325)	19.85 (504)	9.78 (248)	6.61 (168)

Note: Polyalkylene Glycol (PAG)-based oil such as Klubersynth UH1 is not compatible, and cannot be used, with the clear polycarbonate fill cup.

## Clear Oil Fill Cup

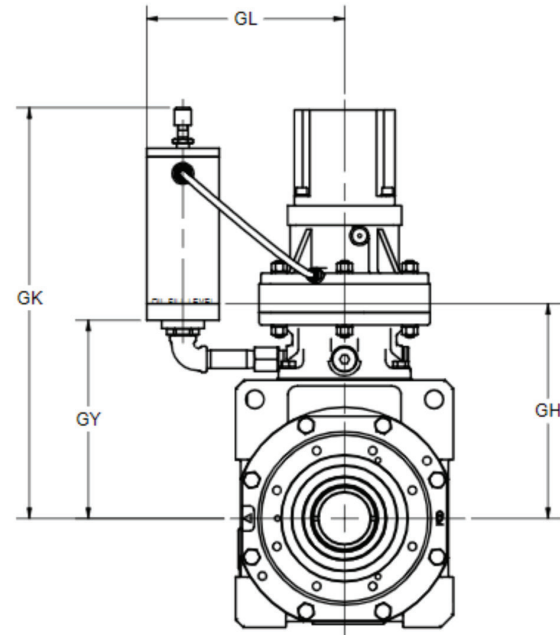

Frame Size	GH	GL	GK	GY
4A10DA	10.94 (278)	8.09 (205)	19.23 (488)	9.16 (233)
4A12DA	11.42 (290)	9.46 (240)	20.05 (509)	9.97 (253)
4A12DB	11.77 (299)	9.46 (240)	20.05 (509)	9.97 (253)
4B12DA	12.87 (327)	9.46 (240)	21.49 (546)	11.42 (290)
4B12DB	13.23 (336)	9.46 (240)	21.49 (546)	11.42 (290)

Note: Polyalkylene Glycol (PAG)-based oil such as Klubersynth UH1 is not compatible, and cannot be used, with the clear polycarbonate fill cup.

## Shaft Diameters - Keyed Hollow Bore

All dimensions are in inches.

Bore (in)	Frame Size					
	4A	4B	4C	4D	4E	4F
1-7/16"	○					
1-1/2"	○					
1-5/8"	○					
1-11/16"	○					
1-3/4"	○					
1-13/16"	○	○				
1-7/8"	○	○				
1-15/16"	●◇	○				
2"	●◇	○				
2-3/16"	●◇	●◇				
2-1/4"		○				
2-3/8"		●◇	○			
2-7/16"		●◇	○			
2-1/2"		○	○			
2-9/16"			○			
2-5/8"			○			
2-3/4"			●◇			
2-7/8"			○			
2-15/16"			●◇	○		
3"			○	○		
3-1/8"			○	○		
3-3/16"			○	○		
3-1/4"			○	○		
3-3/8"			○	○	○	○
3-7/16"			○	●	○	○
3-1/2"			○	○	○	○
3-5/8"				○	○	○
3-3/4"				○	○	○
3-7/8"				○	○	○
3-15/16"				○	○	○
4"				○	●	○
4-7/16"						○
4-1/2"						●
4-3/4"						○

All dimensions are in millimeters.

Bore (mm)	Frame Size					
	4A	4B	4C	4D	4E	4F
35	○					
40	○					
45	○	○				
50	○	○				
55	●	○				
60		○	○			
65		●	○			
70			○			
75			●	○		
80				○		
85				●	○	
90				○	○	
95					○	
100					●	
105					○	
110						○
115						○
120						●

- Standard shaft size (Carbon steel material)
- On-demand shaft size (Carbon steel material)
- ◇ Standard Stainless Steel shaft size

- Note:
- 1) The customer is responsible for validating the strength of the driven shaft.
  - 2) Consult factory for the price and delivery of 'On-demand' shaft sizes.
  - 3) If the required shaft size is different than the above mentioned sizes, please consult the factory.



## Shaft Diameters - Shrink Disc

All dimensions are in inches.

Bore (in)	Frame Size					
	4A	4B	4C	4D	4E	4F
1- 15/16"	● ◊					
2"	● ◊	●				
2-3/16"	● ◊	● ◊				
2-3/8"		● ◊				
2-7/16"		● ◊				
2-3/4"			● ◊			
2-15/16"			● ◊			
3-15/16"						

- Standard shaft size (Carbon steel material)
- Optional shaft size (Carbon steel material)
- ◊ Standard Stainless Steel shaft size

Note: 1) Shrink disc bore with LEFT as well as RIGHT projections are available (refer figures on page 3.5).  
 2) Shrink disc bore size mentioned in above is ødw dimension of the Table on page 3.6  
 3) If the required shaft size is different than the above mentioned sizes, please consult the factory.

All dimensions are in millimeters.

Bore (mm)	Frame Size					
	4A	4B	4C	4D	4E	4F
55	●					
65		●				
66						
75			●			
85				●		
100					●	
120						●

## Shaft Diameters - Taper Grip Bushing

Please refer øU dimensions in 'Dimensions' section for the shaft size range (Min. & Max.)

## Shaft Diameters- Solid Shaft

All dimensions are in inches.

Bore (in)	Frame Size					
	4A	4B	4C	4D	4E	4F
1-7/16"	○					
1-1/2"	○					
1-9/16"	○					
1-5/8"	○					
1-3/4"	○					
1-7/8"	○	○				
1-15/16"	○	○				
2"	●	○				
2-1/8"	○	○				
2-3/16"	○	○				
2-1/4"		○				
2.236"		○				
2-3/8"		○	○			
2-7/16"		○	○			
2-1/2"		○	○			
2-5/8"		○	○			
2-3/4"		○	○			
2-7/8"		●	○	○		
2-15/16"			○	○		
3"			○	○		
3-1/8"			●	○		
3-1/4"				○		
3-3/8"				○	○	
3-7/16"				○	○	
3-5/8"				●	○	
3-7/8"					○	
4"					○	
4-3/8"					●	○
4-7/16"						○
4-1/2"					○	○
4-5/8"						○
4-3/4"						●

Note: 1) The customer is responsible for validating the strength of the driven shaft.  
 2) Consult factory for the price and delivery of 'On-demand' shaft sizes.  
 3) If the required shaft size is different than the above mentioned sizes, please consult the factory.  
 4) Solid shaft with LEFT, RIGHT as well as DOUBLE EXTENDED projections are available.

All dimensions are in millimeters.

Bore (mm)	Frame Size					
	4A	4B	4C	4D	4E	4F
25	○					
45	○					
50	●					
55						
60		○				
65		●				
70						
75			○			
80			●			
85				○		
90				○		
95				●	○	
100					○	
110					●	
115						
120						
130						●

- Standard shaft size (Carbon steel material)
- Optional shaft size (Carbon steel material)

# Options

## Industry Packages

When ordering, add the Special Specification Code (SSC) that meets your requirements to the end of the model number, to obtain the features listed below. Example: LHYMS3-4A105KB-EPY1-39 YBA5, Q8E: 2"

Note that Q8E is the output diameter SSC code required at the end of every model number (refer to Nomenclature Requirements page 2.4)

Four food-grade packages are available for use in machinery where there is incidental food contact. (Chemi SHIELD, SHIELD360, Food-Grade, and Ultra SHIELD360)

The food-grade optional packages are available for BBB4 frame sizes A, B, and C.

Modification	Chemical Duty	Chemi SHIELD 360*	SHIELD 360*	Ultra SHIELD 360*	Food Grade	Low Temp	High Temp	Weather Proof IP54	Wash-down IP55
Special Specification Code	A32	YBA7	YBA5	YBA8	YBA1	C30	D50	A11/A10	A1C/N43
<b>Motor Portion</b>									
Gasketed Conduit Box	X	X	X		X			X	X
V Ring Seal-Fan End	X	X	X		X			X	X
Special Oil Seal						X	X		
Special Windings						X	X		
Sealer @ Jpines	X	X	X		X			X	X
Special Fan						X			X
Epoxy Paint	X								
FDA Epoxy Paint			X		X				
FDA White Acrylic Top Coat		X							
FDA Stainless Grey Acrylic Top Coat									
FDA Stainless Grey 2 Part Epoxy Clear Top Coat	X	X	X						
<b>Brake Cover Seal</b>									
Sever Duty Breather	X	X	X	X				X	X
Epoxy Paint	X								X
FDA Epoxy Paint					X				
FDA White Acrylic Top Coat			X						
FDA Stainless Grey Acrylic Top Coat		X							
FDA Stainless Grey 2 Part Epoxy Clear Top Coat				X					
FDA Grease Oil/Grease			X	X	X				
Low Temp Grease/Oil						X			
High Temp Grease/Oil							X		
Double Output Seals			X		X	X	X	X	X
Corrosion Preventative Plugs		X		X			X		
Low Temperature Seals									
FKM AM Cassette Seal		X	X	X		X			
FKM (Viton) Seal	X								
Stainless or Tesa Namplate	X	X		X					
Stainless Output Shaft		X		X					

Stainless Steel Solid Shaft - maximum torque ratings with standard solid shaft diameters are the same as those listed in this catalog for standard models. Consult the factory when ordering smaller than standard diameters, or if there will be overhung load.

\* UltraShield360™ available in quill input option only

Low Temp Package = -30 degrees C Maximum. For lower temperature requirements consult factory.

High Temp Package = 50 degrees C Maximum. For higher temperature requirements consult factory.

# 4

# Technical Information

---

Cyclo® BBB4

Technical  
Information

Bevel Buddybox catalog ratio 11, 13, 14, 16, and 18 utilize a planetary gearset for the first reduction stage.

The exact ratio of planetary gearing can be calculated using the following formula:

$$i_{\text{PLANETARY}} = (Z_{\text{SUN}} + Z_{\text{RING}}) / Z_{\text{SUN}}$$

where:  $Z_{\text{SUN}}$  = Number of teeth in the sun gear

$Z_{\text{RING}}$  = Number of teeth in the ring gear

The overall gearbox ratio can be determined using the following formula:

$$i_{\text{OVERALL}} = (Z_{\text{GEAR}} / Z_{\text{PINION}}) \times i_{\text{PLANETARY}}$$

where:  $Z_{\text{GEAR}}$  = Number of teeth in the bevel gear

$Z_{\text{PINION}}$  = Number of teeth in the bevel pinion

**Table 4.1 BBB4 with Planetary Input - Exact Ratios**

Nominal Ratio	Frame Size	Gearing Tooth Count				Calculated Ratio $i_{\text{OVERALL}}$
		Bevel		Planetary		
		$Z_{\text{GEAR}}$	$Z_{\text{PINION}}$	$Z_{\text{SUN}}$	$Z_{\text{RING}}$	
11	4A100/5	35	10	46	92	10.50
	4A120/5	35	10	60	120	10.50
	4A140/5	35	10	54	114	10.89
	4B120/5	35	10	60	120	10.50
	4B140/5	35	10	54	114	10.89
	4B160/5	35	10	60	126	10.85
	4C140/5	35	10	54	114	10.89
	4C160/5	35	10	60	126	10.85
	4C170/5	35	10	58	122	10.86
	4D170/5	35	10	58	122	10.86
	4D180/5	35	10	68	136	10.50
	4E170/5	35	10	58	122	10.86
	4E180/5	35	10	68	136	10.50
	4E190/5	35	10	66	138	10.82
13	4A100/5	32	10	34	104	12.99
	4A120/5	32	10	45	135	12.80
	4A140/5	32	10	43	131	12.95
	4B120/5	32	10	45	135	12.80
	4B140/5	32	10	43	131	12.95
	4B160/5	32	10	48	144	12.80
	4C140/5	32	10	43	131	12.95
	4C160/5	32	10	48	144	12.80
	4C170/5	32	10	44	136	13.09
	4D170/5	32	10	44	136	13.09
	4D180/5	32	10	44	136	13.09
	4E170/5	32	10	44	136	13.09
	4E180/5	32	10	44	136	13.09
	4E190/5	32	10	45	138	13.01
14	4A100/5	35	10	34	104	14.21
	4A120/5	35	10	45	135	14.00
	4A140/5	35	10	43	131	14.16
	4B120/5	35	10	45	135	14.00
	4B140/5	35	10	43	131	14.16
	4B160/5	35	10	48	144	14.00
	4C140/5	35	10	43	131	14.16
	4C160/5	35	10	48	144	14.00
	4C170/5	35	10	44	136	14.32
	4D170/5	35	10	44	136	14.32
	4D180/5	35	10	44	136	14.32
	4E170/5	35	10	44	136	14.32
	4E180/5	35	10	44	136	14.32
	4E190/5	35	10	45	138	14.23
16	4A100/5	32	10	30	114	15.36
	4A120/5	32	10	38	148	15.66
	4A140/5	32	10	36	144	16.00
	4B120/5	32	10	38	148	15.66
	4B140/5	32	10	36	144	16.00
	4B160/5	32	10	39	159	16.25
	4C140/5	32	10	36	144	16.00
	4C160/5	32	10	39	159	16.25
	4C170/5	32	10	38	154	16.17
	4D170/5	32	10	38	154	16.17
	4D180/5	32	10	35	136	15.63
	4E170/5	32	10	38	154	16.17
	4E180/5	32	10	35	136	15.63
	4E190/5	32	10	36	138	15.47
18	4A100/5	35	10	30	114	16.80
	4A120/5	35	10	38	148	17.13
	4A140/5	35	10	36	144	17.50
	4B120/5	35	10	38	148	17.13
	4B140/5	35	10	36	144	17.50
	4B160/5	35	10	39	159	17.77
	4C140/5	35	10	36	144	17.50
	4C160/5	35	10	39	159	17.77
	4C170/5	35	10	38	154	17.68
	4D170/5	35	10	38	154	17.68
	4D180/5	35	10	35	136	17.10
	4E170/5	35	10	38	154	17.68
	4E180/5	35	10	35	136	17.10
	4E190/5	35	10	36	138	16.92
18	4F180/5	35	10	35	136	17.10
	4F190/5	35	10	36	138	16.92

**Table 4.1 BBB4 with Planetary Input - Exact Ratios continued**

Nominal Ratio	Frame Size	Gearing Tooth Count				Calculated Ratio $i_{\text{OVERALL}}$
		Bevel		Planetary		
		$Z_{\text{GEAR}}$	$Z_{\text{PINION}}$	$Z_{\text{SUN}}$	$Z_{\text{RING}}$	
14	4A100/5	35	10	34	104	14.21
	4A120/5	35	10	45	135	14.00
	4A140/5	35	10	43	131	14.16
	4B120/5	35	10	45	135	14.00
	4B140/5	35	10	43	131	14.16
	4B160/5	35	10	48	144	14.00
	4C140/5	35	10	43	131	14.16
	4C160/5	35	10	48	144	14.00
	4C170/5	35	10	44	136	14.32
	4D170/5	35	10	44	136	14.32
	4D180/5	35	10	44	136	14.32
	4E170/5	35	10	44	136	14.32
	4E180/5	35	10	44	136	14.32
	4E190/5	35	10	45	138	14.23
16	4F180/5	35	10	44	136	14.32
	4F190/5	35	10	45	138	14.23
	4A100/5	32	10	30	114	15.36
	4A120/5	32	10	38	148	15.66
	4A140/5	32	10	36	144	16.00
	4B120/5	32	10	38	148	15.66
	4B140/5	32	10	36	144	16.00
	4B160/5	32	10	39	159	16.25
	4C140/5	32	10	36	144	16.00
	4C160/5	32	10	39	159	16.25
	4C170/5	32	10	38	154	16.17
	4D170/5	32	10	38	154	16.17
	4D180/5	32	10	35	136	15.63
	4E170/5	32	10	38	154	16.17
4E180/5	32	10	35	136	15.63	
4E190/5	32	10	36	138	15.47	
18	4F180/5	32	10	35	136	15.63
	4F190/5	32	10	36	138	15.47
	4A100/5	35	10	30	114	16.80
	4A120/5	35	10	38	148	17.13
	4A140/5	35	10	36	144	17.50
	4B120/5	35	10	38	148	17.13
	4B140/5	35	10	36	144	17.50
	4B160/5	35	10	39	159	17.77
	4C140/5	35	10	36	144	17.50
	4C160/5	35	10	39	159	17.77
	4C170/5	35	10	38	154	17.68
	4D170/5	35	10	38	154	17.68
	4D180/5	35	10	35	136	17.10
	4E170/5	35	10	38	154	17.68
4E180/5	35	10	35	136	17.10	
4E190/5	35	10	36	138	16.92	
18	4F180/5	35	10	35	136	17.10
	4F190/5	35	10	36	138	16.92

Technical Information

Technical Information



**Bevel Buddybox catalog ratios greater than 18:1 utilize Cyclo as the first (or first and second) reduction stage**

Cyclo reduction ratios are exact thus the exact overall Bevel Buddybox reduction ratio can be calculated as:

$$i_{OVERALL} = (Z_{GEAR} / Z_{PINION}) \times i_{CYCLO}$$

where:  $Z_{GEAR}$  = Number of teeth in the bevel gear

$Z_{PINION}$  = Number of teeth in the bevel pinion

**Table 4.2 BBB4 with Cyclo Input - Exact Ratios**

Single Reduction Cyclo

Nominal Ratio	Frame Size	Bevel Gear Tooth Count		Cyclo Ratio ( $i_{CYCLO}$ )	Calculated Ratio $i_{OVERALL}$
		$Z_{GEAR}$	$Z_{PINION}$		
21	ALL <sup>[1]</sup>	35	10	6	21.00
22		32	10	7	22.40
25		35	10	7	24.50
28		35	10	8	28.00
35		32	10	11	35.20
39		35	10	11	38.50
46		35	10	13	45.50
53		35	10	15	52.50
60		35	10	17	59.50
67		32	10	21	67.20
74		35	10	21	73.50
80		32	10	25	80.00
88		35	10	25	87.50
102		35	10	29	101.50
112		32	10	35	112.00
123		35	10	35	122.50
151		35	10	43	150.50
179		35	10	51	178.50
207		35	10	59	206.50
249	35	10	71	248.50	
305	35	10	87	304.50	
417	4A10	35	10	119	416.50

Note [1]: 22:1 and 25:1 ratios are not available for 4A100/5 and 4A110/5 sizes.

**Table 4.3 BBB4 with Cyclo Input - Exact Ratios**

Double Reduction Cyclo

Nominal Ratio	Frame Size	Bevel Gearing Tooth Count		Cyclo Ratio ( $i_{CYCLO}$ )	Calculated Ratio $i_{OVERALL}$
		$Z_{GEAR}$	$Z_{PINION}$		
364	ALL	35	10	104	364.0
424		35	10	121	423.5
501		35	10	143	500.5
578		35	10	165	577.5
683		35	10	195	682.5
809		35	10	231	808.5
956		35	10	273	955.5
1117		35	10	319	1116.5
1320		35	10	377	1319.5
1656		35	10	473	1655.5
1957		35	10	559	1956.5
2272		35	10	649	2271.5
2559		35	10	731	2558.5
2944		35	10	841	2943.5
3511		35	10	1003	3510.5
4365		35	10	1247	4364.5
5177		35	10	1479	5176.5
6472		35	10	1849	6471.5
7228		35	10	2065	7227.5
8880		35	10	2537	8879.5
10658		35	10	3045	10657.5
12184		35	10	3481	12183.5
15530		35	10	4437	15529.5
17966		35	10	5133	17965.5
21620		35	10	6177	21619.5
26492		35	10	7569	26491.5

Technical Information

Technical Information

# Special Load Guidelines Overhung Load

# Special Load Guidelines Output Shaft Overhung Load continued

## Reducer/Gearmotor Output Shaft Allowable Overhung Load<sup>[1]</sup>

When a sprocket, sheave, or gear is mounted on the slowspeed of a reducer, an overhung load is applied on that shaft. It is necessary to check if the shaft of the Cyclo® BBB4 Speed Reducer will allow the overhung load. Calculate the overhung load using the following formulas:

### 1) Radial load, Pr

$$Pr = \frac{TI}{R} \leq \frac{Pro}{Lf \cdot Cf \cdot Sf} \quad (\text{lbs, N})$$

### 2) Axial Load, Pa

$$Pa \leq \frac{Pao}{Cf \cdot Sf} \quad (\text{lbs, N})$$

### 3) When there is combined radial and axial loading on the output shaft

$$\left( \frac{Pr}{Pro} + \frac{Pa}{Pao} \right) \cdot Cf \cdot Sf \leq 1 \quad (\text{lbs, N})$$

#### LEGEND

- Pr** = Actual radial load (lbs, N)
- TI** = Actual transmitted torque on slow speed shaft of reducer (lb-in, N-m)
- R** = Pitch circle radius of sprocket, gear, pulley, etc. (inch, meter)
- Pro** = Allowable radial load (lbs, N)
- Pa** = Actual axial load (lbs, N)
- Pao** = Allowable axial load (lbs, N)
- Cf** = Coupling factor
- Sf** = Service factor
- Lf** = Load Location factor = 1.0

The values shown in the tables within are the allowable OHL<sup>[2]</sup> when it is applied to the center of the solid shaft extension or at the load-side edge of the hollow bore. Please consult the factory when the center point of the load is located elsewhere.

**Table 4.4 Coupling Factor, Cf**

Type of Connection	Cf
General Purpose Chain	1.0
Machined Gear, Pinion or Synchronous Belt	1.25
V-Belt	1.5
Flat Belt	2.5

**Table 4.5 Service Factor, Sf**

Shock Factor	Sf
No Shock	1.0
Moderate Shock	1.5
Heavy Shock	2.0

## Overhung Load, capacity for solid output shaft

OHL ratings assume there is no axial load applied to the shaft and that the unit is horizontal to floor/foundation. (Mounting feet at bottom or top.) Consult factory when it is wall mount or vertical position. When flange mounted, OHL location should be same side as flange. Consult factory when OHL is opposite flange side. Use ISO/JIS Class 12.9 for mounting hardware.

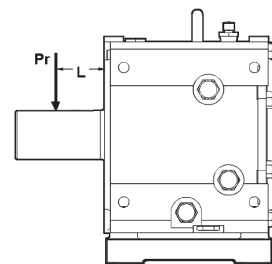

Loading position L is the distance from the output shaft shoulder

Pro from table must be ≥ Pr

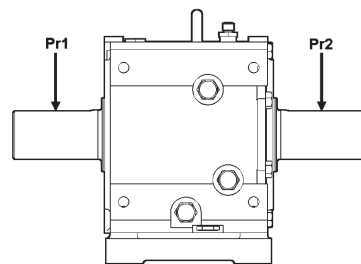

For double extension, Pr1 and Pr2 is assumed to be in the same direction. Pro from table must be ≥ Pr1 + Pr2

**Table 4.6a<sup>[1]</sup> Allowable Overhung Load for Output Shaft (Solid Output Shaft) (Cf, Sf = 1)**

Force Units: lbs, (N)

Model	L inch (mm)	Output Shaft, RPM									
		5	10	20	30	35	45	50	60	75	90
4A100 4A105 4A110 4A115 4A120 4A125 4A140 4A145	0.75 (19.1)	7170 (31890)	8360 (37180)	7190 (31980)	6110 (27170)	5740 (25530)	5160 (22950)	4940 (21970)	4570 (20320)	4120 (18320)	3790 (16850)
	1.00 (25.4)	6850 (30460)	7490 (33310)	6960 (30950)	5940 (26420)	5560 (24730)	5020 (22320)	4790 (21300)	4420 (19660)	3990 (17740)	3670 (16320)
	1.25 (31.8)	5940 (26420)	6240 (27750)	6240 (27750)	5760 (25620)	5410 (24060)	4870 (21660)	4640 (20630)	4290 (19080)	3890 (17300)	3570 (15870)
	1.50 (38.1)	5230 (23260)	5340 (23750)	5340 (23750)	5340 (23750)	5260 (23390)	4740 (21080)	4520 (20100)	4170 (18540)	3770 (16760)	3470 (15430)
	1.75 (44.5)	4670 (20770)	4670 (20770)	4670 (20770)	4670 (20770)	4670 (20770)	4590 (20410)	4390 (19520)	4070 (18100)	3670 (16320)	3370 (14980)
	1.88 (47.6)	3970 (17650)	4170 (18540)	4170 (18540)	4170 (18540)	4170 (18540)	4170 (18540)	4170 (18540)	3970 (17650)	3570 (15870)	3290 (14630)
	2.00 (50.8)	3420 (15210)	3740 (16630)	3740 (16630)	3740 (16630)	3740 (16630)	3740 (16630)	3740 (16630)	3740 (16630)	3490 (15520)	3190 (14180)
	2.50 (63.5)	2970 (13210)	3120 (13870)	3120 (13870)	3120 (13870)	3120 (13870)	3120 (13870)	3120 (13870)	3120 (13870)	3120 (13870)	3040 (13520)
	3.00 (76.2)	2610 (11600)	2670 (11870)	2670 (11870)	2670 (11870)	2670 (11870)	2670 (11870)	2670 (11870)	2670 (11870)	2670 (11870)	2670 (11870)
	3.50 (88.9)	2340 (10400)	2340 (10400)	2340 (10400)	2340 (10400)	2340 (10400)	2340 (10400)	2340 (10400)	2340 (10400)	2340 (10400)	2340 (10400)
	4.00 (102)	2110 (9380)	2080 (9250)	2080 (9250)	2080 (9250)	2080 (9250)	2080 (9250)	2080 (9250)	2080 (9250)	2080 (9250)	2080 (9250)
	0.75 (19.1)	11800 (52480)	11830 (52610)	8810 (39180)	7340 (32640)	6810 (30290)	6010 (26730)	5690 (25300)	5160 (22950)	4570 (20320)	4120 (18320)
	1.00 (25.4)	12350 (54930)	11530 (51280)	8610 (38290)	7160 (31840)	6660 (29620)	5860 (26060)	5560 (24730)	5040 (22410)	4470 (19880)	4020 (17880)
	1.25 (31.8)	12620 (56130)	11260 (50080)	8410 (37400)	6990 (31090)	6490 (28860)	5740 (25530)	5440 (24190)	4940 (21970)	4370 (19430)	3920 (17430)
1.50 (38.1)	11720 (52130)	11010 (48970)	8210 (36510)	6840 (30420)	6340 (28200)	5610 (24950)	5310 (23610)	4820 (21430)	4270 (18990)	3820 (16990)	
1.75 (44.5)	10460 (46520)	10460 (46520)	8040 (35760)	6660 (29620)	6210 (27620)	5460 (24280)	5190 (23080)	4720 (20990)	4170 (18540)	3740 (16630)	
1.88 (47.6)	8870 (39450)	9310 (41410)	7860 (34960)	6540 (29080)	6060 (26950)	5360 (23840)	5060 (22500)	4620 (20540)	4070 (18100)	3670 (16320)	
2.00 (50.8)	7650 (34020)	8360 (37180)	7690 (34200)	6390 (28420)	5940 (26420)	5240 (23300)	4970 (22100)	4520 (20100)	3990 (17740)	3570 (15870)	
2.50 (63.5)	6650 (29570)	6990 (31090)	6990 (31090)	6110 (27170)	5690 (25300)	5020 (22320)	4770 (21210)	4320 (19210)	3820 (16990)	3420 (15210)	
3.00 (76.2)	5870 (26100)	5990 (26640)	5990 (26640)	5890 (26190)	5460 (24280)	4820 (21430)	4570 (20320)	4140 (18410)	3670 (16320)	3290 (14630)	
3.50 (88.9)	5240 (23300)	5240 (23300)	5240 (23300)	5240 (23300)	5240 (23300)	4640 (20630)	4390 (19520)	3990 (17740)	3520 (15650)	3170 (14100)	
4.00 (102)	4720 (20990)	4640 (20630)	4640 (20630)	4640 (20630)	4640 (20630)	4470 (19880)	4240 (18850)	3840 (17080)	3390 (15070)	3040 (13520)	
4.50 (114)	4310 (19170)	4190 (18630)	4190 (18630)	4190 (18630)	4190 (18630)	4190 (18630)	4090 (18190)	3720 (16540)	3270 (14540)	2940 (13070)	
5.00 (127)	3320 (14760)	3490 (15520)	3490 (15520)	3490 (15520)	3490 (15520)	3490 (15520)	3490 (15520)	3470 (15430)	3070 (13650)	2740 (12180)	

**Note [1]:** For output speeds that are in between those detailed in Tables 4.6a through 4.7c, the overhung load capacity may be calculated through interpolation.  
**[2]:** OHL = Overhung Load

**Note [1]:** For output speeds that are in between those detailed in Tables 4.6a through 4.7c, the overhung load capacity may be calculated through interpolation.

# Special Load Guidelines Output Shaft Overhung Load continued

**Table 4.6b Allowable Overhung Load for Output Shaft (Solid Output Shaft) (Cf, Sf = 1)**

Force Units: lbs, (N)

Model	L inch (mm)	Output shaft, RPM									
		5	10	20	30	35	45	50	60	75	90
<b>4C140</b> <b>4C145</b> <b>4C160</b> <b>4C165</b> <b>4C170</b> <b>4C175</b>	0.75 (19.1)	16770 (74590)	16650 (74050)	12330 (54840)	10180 (45280)	9460 (42070)	8310 (36960)	7860 (34960)	7090 (31530)	6240 (27750)	5560 (24730)
	1.00 (25.4)	17560 (78100)	16280 (72410)	12060 (53640)	9960 (44300)	9240 (41090)	8110 (36070)	7690 (34200)	6940 (30860)	6090 (27080)	5440 (24190)
	1.25 (31.8)	17980 (79970)	15930 (70850)	11810 (52530)	9760 (43410)	9040 (40200)	7940 (35310)	7510 (33400)	6790 (30200)	5960 (26510)	5310 (23610)
	1.50 (38.1)	18210 (80990)	15580 (69290)	11530 (51280)	9540 (42430)	8840 (39320)	7790 (34640)	7360 (32730)	6640 (29530)	5840 (25970)	5210 (23170)
	1.75 (44.5)	18280 (81300)	15250 (67830)	11310 (50300)	9340 (41540)	8660 (38510)	7610 (33840)	7190 (31980)	6510 (28950)	5710 (25390)	5090 (22640)
	1.88 (47.6)	17120 (76140)	14960 (66540)	11080 (49280)	9160 (40740)	8490 (37760)	7460 (33180)	7060 (31400)	6360 (28280)	5590 (24860)	4990 (22190)
	2.00 (50.8)	15780 (70180)	14660 (65200)	10860 (48300)	8990 (39980)	8310 (36960)	7310 (32510)	6910 (30730)	6240 (27750)	5490 (24410)	4890 (21750)
	2.50 (63.5)	13690 (60890)	14080 (62620)	10430 (46390)	8640 (38430)	7990 (35530)	7040 (31310)	6640 (29530)	6010 (26730)	5260 (23390)	4720 (20990)
	3.00 (76.2)	12090 (53770)	12330 (54840)	10060 (44740)	8310 (36960)	7710 (34290)	6760 (30060)	6390 (28420)	5790 (25750)	5060 (22500)	4540 (20190)
	3.50 (88.9)	10780 (47940)	10780 (47940)	9690 (43100)	8010 (35620)	7440 (33090)	6540 (29080)	6160 (27390)	5590 (24860)	4890 (21750)	4370 (19430)
	4.00 (102)	9740 (43320)	9590 (42650)	9360 (41630)	7740 (34420)	7160 (31840)	6310 (28060)	5960 (26510)	5390 (23970)	4720 (20990)	4220 (18770)
	4.50 (114)	8860 (39400)	8610 (38290)	8610 (38290)	7490 (33310)	6940 (30860)	6090 (27080)	5760 (25620)	5210 (23170)	4570 (20320)	4090 (18190)
	5.00 (127)	6840 (30420)	7190 (31980)	7190 (31980)	7010 (31180)	6490 (28860)	5710 (25390)	5390 (23970)	4890 (21750)	4290 (19080)	3820 (16990)
	6.00 (152)	6040 (26860)	6160 (27390)	6160 (27390)	6160 (27390)	6110 (27170)	5360 (23840)	5090 (22640)	4590 (20410)	4040 (17960)	3590 (15960)

# Special Load Guidelines Output Shaft Overhung Load continued

**Table 4.6c Allowable Overhung Load for Output Shaft (Solid Output Shaft) (Cf, Sf = 1)**

Force Units: lbs, (N)

Model	L inch (mm)	Output Shaft, RPM									
		5	10	20	30	35	45	50	60	75	90
<b>4D160</b> <b>4D165</b> <b>4D170</b> <b>4D175</b> <b>4D180</b> <b>4D185</b>	0.75 (19.1)	21850 (97180)	23970 (106610)	17730 (78860)	14630 (65070)	13530 (60180)	11880 (52840)	11210 (49860)	10110 (44960)	8860 (39400)	7890 (35090)
	1.00 (25.4)	23060 (102570)	23550 (104750)	17400 (77390)	14360 (63870)	13280 (59060)	11660 (51860)	11010 (48970)	9940 (44210)	8690 (38650)	7740 (34420)
	1.25 (31.8)	23590 (104920)	23100 (102740)	17080 (75970)	14080 (62620)	13030 (57950)	11430 (50840)	10810 (48080)	9740 (43320)	8540 (37980)	7590 (33760)
	1.50 (38.1)	23940 (106480)	22700 (100960)	16780 (74630)	13830 (61510)	12810 (56970)	11230 (49950)	10610 (47190)	9560 (42520)	8390 (37310)	7460 (33180)
	1.75 (44.5)	24070 (107060)	22300 (99190)	16480 (73300)	13580 (60400)	12580 (55950)	11030 (49060)	10410 (46300)	9410 (41850)	8240 (36650)	7340 (32640)
	1.88 (47.6)	22610 (100560)	21900 (97410)	16180 (71960)	13360 (59420)	12360 (54970)	10830 (48170)	10230 (45500)	9240 (41090)	8090 (35980)	7210 (32070)
	2.00 (50.8)	21420 (95270)	21520 (95720)	15900 (70720)	13130 (58400)	12160 (54080)	10660 (47410)	10060 (44740)	9090 (40430)	7960 (35400)	7090 (31530)
	2.50 (63.5)	20310 (90330)	20820 (92600)	15380 (68410)	12680 (56400)	11760 (52300)	10310 (45850)	9740 (43320)	8790 (39090)	7690 (34200)	6840 (30420)
	3.00 (76.2)	17910 (79660)	18280 (81300)	14910 (66310)	12280 (54620)	11380 (50610)	9990 (44430)	9440 (41980)	8510 (37850)	7440 (33090)	6640 (29530)
	3.50 (88.9)	16000 (71160)	16000 (71160)	14430 (64180)	11910 (52970)	11030 (49060)	9660 (42960)	9140 (40650)	8240 (36650)	7210 (32070)	6410 (28510)
	4.00 (102)	14440 (64220)	14210 (63200)	14010 (62310)	11560 (51410)	10680 (47500)	9390 (41760)	8860 (39400)	7990 (35530)	6990 (31090)	6240 (27750)
	4.50 (114)	13180 (58620)	12810 (56970)	12810 (56970)	11210 (49860)	10380 (46170)	9110 (40520)	8610 (38290)	7760 (34510)	6790 (30200)	6040 (26860)
	5.00 (127)	10150 (45140)	10660 (47410)	10660 (47410)	10610 (47190)	9810 (43630)	8610 (38290)	8140 (36200)	7340 (32640)	6410 (28510)	5710 (25390)
	6.00 (152)	8950 (39800)	9140 (40650)	9140 (40650)	9140 (40650)	9140 (40650)	8160 (36290)	7710 (34290)	6960 (30950)	6090 (27080)	5410 (24060)
	7.00 (178)	7990 (35530)	7990 (35530)	7990 (35530)	7990 (35530)	7990 (35530)	7760 (34510)	7310 (32510)	6610 (29400)	5790 (25750)	5140 (22860)

**Note [1]:** For output speeds that are in between those detailed in Tables 4.6a through 4.7c, the overhung load capacity may be calculated through interpolation.

**Note [1]:** For output speeds that are in between those detailed in Tables 4.6a through 4.7c, the overhung load capacity may be calculated through interpolation.







# Special Load Guidelines Output Shaft Allowable Axial Load

Table 4.8 Allowable Axial Load (Common to Hollow and Solid Shafts)

[Units] Upper line: lbs; lower line: (N)

Frame Size	Output Shaft Speed r/min									
	5	10	20	30	35	45	50	60	75	90
4A10 □, 4A11 □, 4A12 □, 4A14 □	4968 (22100)	4968 (22100)	4968 (22100)	4586 (20400)	4249 (18900)	3709 (16500)	3507 (15600)	3147 (14000)	2743 (12200)	2428 (10800)
4B12 □, 4B14 □, 4B16 □	9329 (41500)	8835 (39300)	6227 (27700)	4923 (21900)	4474 (19900)	3754 (16700)	3462 (15400)	2990 (13300)	2450 (10900)	2025 (9010)
4C14 □, 4C16 □, 4C17 □	14567 (64800)	10903 (48500)	7373 (32800)	5620 (25000)	4991 (22200)	4024 (17900)	3642 (16200)	2990 (13300)	2248 (10000)	1675 (7450)
4D16 □, 4D17 □, 4D18 □	20816 (92600)	14859 (66100)	9981 (44400)	7531 (33500)	6677 (29700)	5328 (23700)	4811 (21400)	3912 (17400)	2877 (12800)	2070 (9210)
4E17 □, 4E18 □, 4E19 □	20974 (93300)	20569 (91500)	14297 (63600)	11150 (49600)	10049 (44700)	8340 (37100)	7666 (34100)	6542 (29100)	5215 (23200)	4204 (18700)
4F18 □, 4F19 □	33720 (150000)	33720 (150000)	24503 (109000)	19670 (87500)	17962 (79900)	15331 (68200)	14297 (63600)	12544 (55800)	10521 (46800)	8947 (39800)

\*The □ mark of each frame size represents 0, 5, DA, DB, or DC.  
Above values are valid when no radial load is applied on the shaft, and 12.9 grade mounting bolts are used.

# Special Load Guidelines Input Shaft Overhung Load

## Reducer/Gearmotor Input Shaft Allowable Overhung Load

The radial load acting on the high speed shaft (ie: unit supplied as a reducer) may be calculated with the following formula:

$$Pr \leq \frac{Pro}{Lf \cdot Cf \cdot Sf}$$

LEGEND

- Pr = Actual radial load (lbs, N)
- Pro = Allowable radial load (lbs, N)
- Lf = Load Location factor (Table 4.6a)
- Cf = Coupling Factor (Table 4.4)
- Sf = Service factor (Table 4.5)

Figure 4.1 Input Shaft Load Location Factor (Lf)

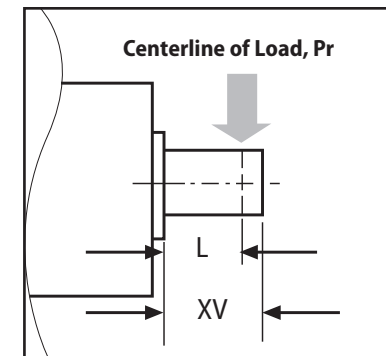

Table 4.9 Input Shaft Load Location Factor (Lf)

Model	L inch/(mm)											
	0.25 (6.35)	0.50 (12.7)	0.75 (19.05)	1.00 (25.4)	1.25 (31.75)	1.50 (38.1)	1.75 (44.45)	2.00 (50.8)	2.50 (63.5)	3.00 (76.2)	3.50 (88.9)	4.00 (101.6)
4A10DA, 4A12DA, 4B12DA, 4B14DA, 4C14DA	0.78	1.07	1.52	2.02	—	—	—	—	—	—	—	—
4A12DB, 4B12DB, 4B14DB, 4C14DB, 4C16DA, 4D16DA, 4D17DA, 4E17DA	0.90	1.09	1.52	2.03	2.53	—	—	—	—	—	—	—
4A100, 4A105, 4C14DC, 4D16DB, 4D17DB, 4D18DA, 4E17DB, 4E18DA, 4F18DA	0.93	1.09	1.52	2.03	2.53	—	—	—	—	—	—	—
4A110, 4A115	0.93	1.09	1.52	2.03	2.53	—	—	—	—	—	—	—
4A120, 4A125, 4B120, 4B125, 4D17DC, 4E17DC, 4E19DA, 4F19DA	0.68	0.87	1.10	1.43	1.77	2.12	2.46	—	—	—	—	—
4C145, 4D18DB, 4E18DB, 4E19DB, 4F18DB, 4F19DB	0.70	0.84	0.98	1.25	1.53	1.83	2.11	—	—	—	—	—
4B160, 4B165, 4C160, 4C165, 4D160, 4D165	0.90	0.94	0.97	1.06	1.22	1.36	1.51	1.66	1.94	—	—	—
4C170, 4C175, 4D170, 4D175, 4E170, 4E175	—	0.91	0.95	0.99	1.09	1.23	1.38	1.51	1.79	2.08	—	—
4D180, 4D185, 4E180, 4E185, 4F180, 4F185	—	—	0.92	0.96	1.01	1.11	1.24	1.37	1.63	1.88	2.15	2.40
4E190, 4E195, 4F190, 4F195	—	—	0.92	0.95	0.99	1.06	1.15	1.26	1.47	1.69	1.90	2.12

**Table 4.10 Input Shaft Overhung Load Capacity Pro (Lf, Cf, Sf=1)**

Force Units: lbs, (N)

Model	Reduction Ratio	Input Speed (RPM)						
		1750	1450	1165	980	870	720	580
4A10DA, 4A12DA, 4B12DA, 4B14DA, 4C14DA	364 - 5177, 7228, 10658	44 (196)	33 (147)	33 (147)	44 (196)	44 (196)	44 (196)	44 (196)
	1849, 2537	11 (49.1)	11 (49.1)	11 (49.1)	11 (49.1)	11 (49.1)	33 (147)	44 (196)
4A12DB, 4B12DB, 4B14DB, 4C14DB, 4C16DA, 4D16DA, 4D17DA, 4E17DA	All Ratios	44 (196)	44 (196)	44 (196)	44 (196)	55 (245)	55 (245)	66 (294)
4A100, 4A105, 4C14DC, 4D16DB, 4D17DB, 4D18DA, 4E17DB, 4E18DA, 4F18DA	11 - 39, 54 - 578, 809, 1117, 1656, 2272 - 10658	99 (441)	99 (441)	110 (491)	121 (540)	132 (589)	132 (589)	132 (589)
	42, 46, 48, 53, 683, 956, 1320, 1957	99 (441)	77 (343)	99 (441)	110 (491)	110 (491)	121 (540)	132 (589)
4A110, 4A115	19 - 28, 67 - 305	99 (441)	77 (343)	99 (441)	110 (491)	110 (491)	121 (540)	132 (589)
	35 - 60	44 (196)	44 (196)	44 (196)	44 (196)	55 (245)	55 (245)	66 (294)
4A120, 4A125, 4B120, 4B125, 4D17DC, 4E17DC, 4E19DA, 4F19DA	11 - 60, 364 - 2559, 3511, 5177	133 (590)	155 (690)	166 (740)	175 (780)	198 (880)	198 (880)	198 (880)
	67 - 305, 2944, 4365, 6472 - 10658	121 (540)	99 (440)	110 (490)	121 (540)	133 (590)	198 (880)	198 (880)
4D18DB, 4E18DB, 4E19DB, 4F18DB, 4F19DB	11 - 74	308 (1370)	308 (1370)	308 (1370)	342 (1520)	364 (1620)	387 (1720)	418 (1860)
	80 - 305	288 (1280)	288 (1280)	288 (1280)	308 (1370)	330 (1470)	353 (1570)	398 (1770)
4A140, 4A145, 4B140, 4B145, 4C140, 4C145	11 - 28	308 (1370)	308 (1370)	308 (1370)	342 (1520)	364 (1620)	387 (1720)	418 (1860)
	35 - 74	277 (1230)	220 (980)	243 (1080)	265 (1180)	277 (1230)	297 (1320)	330 (1470)
	80, 88	243 (1080)	254 (1130)	265 (1180)	288 (1280)	297 (1320)	308 (1370)	330 (1470)
	93 - 305	121 (540)	133 (590)	133 (590)	155 (690)	155 (690)	155 (690)	243 (1080)
4B160, 4B165, 4C160, 4C165, 4D160, 4D165	11 - 88, 163 - 207	398 (1770)	398 (1770)	441 (1960)	463 (2060)	486 (2160)	486 (2160)	486 (2160)
	93 - 151, 227 - 305	243 (1080)	265 (1180)	288 (1280)	308 (1370)	308 (1370)	353 (1570)	398 (1770)
4C170, 4C175, 4D170, 4D175, 4E170, 4E175	All Ratios	463 (2060)	463 (2060)	508 (2260)	508 (2260)	528 (2350)	551 (2450)	596 (2650)
4D180, 4D185, 4E180, 4E185, 4F180, 4F185	All Ratios	618 (2750)	573 (2550)	618 (2750)	661 (2940)	683 (3040)	751 (3340)	771 (3430)
4E190, 4E195, 4F190, 4F195	35 - 88	683 (3040)	683 (3040)	728 (3240)	794 (3530)	816 (3630)	881 (3920)	881 (3920)
	93 - 305	596 (2650)	573 (2550)	638 (2840)	661 (2940)	706 (3140)	751 (3340)	816 (3630)

**Table 4.11 Reducer Moment of Inertia on Motor Shaft of Gearmotor: Hollow Output Shaft, Ratios 11 - 53<sup>(1)</sup>**  
Units: lb·in<sup>2</sup> (x 10<sup>-4</sup> kg·m<sup>2</sup>)

Model	Nominal Reduction Ratio												
	11	13	14	16	18	21	22	25	28	35	39	46	53
4A100	1.57 (4.60)	0.978 (2.86)	0.904 (2.64)	0.608 (1.78)	0.586 (1.72)	0.462 (1.35)	—	—	0.302 (0.884)	0.186 (0.544)	0.176 (0.514)	0.162 (0.475)	0.141 (0.414)
4A105	—	—	—	—	—	0.710 (2.08)	—	—	0.491 (1.44)	0.358 (1.05)	0.348 (1.02)	0.304 (0.891)	0.278 (0.813)
4A110	—	—	—	—	—	—	—	—	0.491 (1.44)	0.358 (1.05)	0.348 (1.02)	0.304 (0.891)	0.278 (0.813)
4A115	—	—	—	—	—	—	—	—	0.491 (1.44)	0.358 (1.05)	0.348 (1.02)	0.304 (0.891)	0.278 (0.813)
4A120	3.86 (11.3)	2.35 (6.89)	2.28 (6.67)	1.70 (4.99)	1.65 (4.84)	1.28 (3.74)	1.44 (4.21)	1.42 (4.14)	0.986 (2.89)	0.608 (1.78)	0.598 (1.75)	0.631 (1.85)	0.589 (1.72)
4A125	—	—	—	—	—	—	—	—	0.986 (2.89)	0.608 (1.78)	0.598 (1.75)	0.631 (1.85)	0.589 (1.72)
4A140	8.32 (24.4)	5.30 (15.5)	5.22 (15.3)	3.77 (11.0)	3.72 (10.9)	3.37 (9.87)	3.47 (10.2)	3.45 (10.1)	2.27 (6.65)	1.61 (4.71)	1.60 (4.68)	1.29 (3.77)	1.16 (3.40)
4A145	—	—	—	—	—	—	—	—	2.27 (6.65)	1.61 (4.71)	1.60 (4.68)	1.29 (3.77)	1.16 (3.40)
4B120	5.24 (15.3)	3.24 (9.48)	3.05 (8.93)	2.30 (6.72)	1.47 (4.31)	1.62 (4.75)	1.73 (5.06)	1.67 (4.88)	1.18 (3.45)	0.726 (2.12)	0.700 (2.05)	0.704 (2.06)	0.644 (1.88)
4B125	—	—	—	—	—	—	—	—	1.18 (3.45)	0.726 (2.12)	0.700 (2.05)	0.704 (2.06)	0.644 (1.88)
4B140	9.69 (28.4)	6.22 (18.2)	6.03 (17.7)	4.37 (12.8)	4.25 (12.4)	3.75 (11.0)	3.79 (11.1)	3.72 (10.9)	2.48 (7.27)	1.74 (5.08)	1.71 (5.01)	1.37 (4.01)	1.22 (3.58)
4B145	—	—	—	—	—	—	—	—	2.48 (7.27)	1.74 (5.08)	1.71 (5.01)	1.37 (4.01)	1.22 (3.58)
4B160	27.7 (81.0)	17.8 (52.1)	17.6 (51.6)	12.1 (35.5)	12.0 (35.1)	8.93 (26.1)	10.1 (29.5)	10.0 (29.3)	6.17 (18.0)	4.41 (12.9)	4.39 (12.8)	3.87 (11.3)	3.46 (10.1)
4B165	—	—	—	—	—	—	—	—	6.17 (18.0)	4.41 (12.9)	4.39 (12.8)	3.87 (11.3)	3.46 (10.1)
4C140	13.7 (40.1)	9.01 (26.4)	8.40 (24.6)	6.20 (18.1)	3.96 (11.6)	4.84 (14.2)	4.73 (13.8)	4.52 (13.2)	3.10 (9.06)	2.12 (6.20)	2.04 (5.96)	1.60 (4.69)	1.40 (4.09)
4C145	—	—	—	—	—	—	—	—	3.10 (9.06)	2.12 (6.20)	2.04 (5.96)	1.60 (4.69)	1.40 (4.09)
4C160	31.9 (93.4)	20.8 (60.8)	20.1 (59.0)	14.0 (40.9)	13.6 (39.7)	10.0 (29.2)	11.0 (32.1)	10.8 (31.6)	6.75 (19.8)	4.78 (14.0)	4.69 (13.7)	4.09 (12.0)	3.63 (10.6)
4C165	—	—	—	—	—	—	—	—	6.75 (19.8)	4.78 (14.0)	4.69 (13.7)	4.09 (12.0)	3.63 (10.6)
4C170	55.0 (161)	35.0 (102)	34.4 (101)	26.4 (77.2)	26.0 (76.0)	23.8 (69.8)	23.4 (68.3)	23.1 (67.7)	17.6 (51.4)	13.3 (38.9)	13.2 (38.6)	12.3 (36.1)	10.9 (31.9)
4C175	—	—	—	—	—	—	—	—	17.6 (51.4)	13.3 (38.9)	13.2 (38.6)	12.3 (36.1)	10.9 (31.9)
4D160	—	—	—	—	—	12.6 (36.8)	13.3 (39.0)	12.7 (37.1)	8.21 (24.0)	5.73 (16.8)	5.47 (16.0)	4.64 (13.6)	4.04 (11.8)
4D165	—	—	—	—	—	—	—	—	8.21 (24.0)	5.73 (16.8)	5.47 (16.0)	4.64 (13.6)	4.04 (11.8)
4D170	68.5 (200)	44.1 (129)	42.2 (123)	32.3 (94.5)	31.1 (90.9)	26.5 (77.5)	25.7 (75.3)	25.1 (73.4)	19.0 (55.7)	14.2 (41.7)	14.0 (40.9)	12.9 (37.7)	11.3 (33.1)
4D175	—	—	—	—	—	—	—	—	19.0 (55.7)	14.2 (41.7)	14.0 (40.9)	12.9 (37.7)	11.3 (33.1)
4D180	104 (304)	52.8 (155)	50.9 (149)	36.4 (107)	35.1 (103)	36.6 (107)	31.5 (92.2)	30.9 (90.3)	26.5 (77.5)	21.5 (62.8)	21.2 (62.1)	18.9 (55.4)	16.6 (48.7)
4D185	—	—	—	—	—	—	—	—	26.5 (77.5)	21.5 (62.8)	21.2 (62.1)	18.9 (55.4)	16.6 (48.7)
4E170	—	—	—	—	—	30.5 (89.2)	29.0 (84.7)	28.0 (82.0)	21.3 (62.3)	15.6 (45.5)	15.2 (44.4)	13.7 (40.2)	12.0 (35.0)
4E175	—	—	—	—	—	—	—	—	21.3 (62.3)	15.6 (45.5)	15.2 (44.4)	13.7 (40.2)	12.0 (35.0)
4E180	120 (351)	62.3 (182)	59.5 (174)	43.0 (126)	41.1 (120)	40.6 (119)	34.7 (102)	33.8 (98.9)	28.7 (84.0)	22.8 (66.7)	22.4 (65.5)	19.8 (57.8)	17.3 (50.6)
4E185	—	—	—	—	—	—	—	—	28.7 (84.0)	22.8 (66.7)	22.4 (65.5)	19.8 (57.8)	17.3 (50.6)
4E190	188 (551)	102 (300)	99.6 (291)	70.7 (207)	68.8 (201)	77.0 (225)	64.9 (190)	64.0 (187)	56.7 (166)	48.5 (142)	48.1 (141)	44.2 (129)	41.9 (123)
4E195	—	—	—	—	—	—	—	—	56.7 (166)	48.5 (142)	48.1 (141)	44.2 (129)	41.9 (123)
4F180	178 (522)	97.6 (286)	92.8 (272)	68.4 (200)	65.1 (190)	52.8 (155)	44.4 (130)	42.7 (125)	35.6 (104)	26.7 (78.1)	26.0 (76.2)	22.4 (65.4)	19.2 (56.3)
4F185	—	—	—	—	—	—	—	—	35.6 (104)	26.7 (78.1)	26.0 (76.2)	22.4 (65.4)	19.2 (56.3)
4F190	234 (686)	131 (383)	126 (369)	91.0 (266)	87.7 (257)	90.0 (263)	75.2 (220)	73.6 (215)	64.1 (187)	52.7 (154)	52.0 (152)	47.0 (138)	44.0 (129)
4F195	—	—	—	—	—	—	—	—	64.1 (187)	52.7 (154)	52.0 (152)	47.0 (138)	44.0 (129)

Note: (1) The inertia tables do not include the inertia of the integral motors. Total unit inertia is obtained by adding the reducer inertia to the motor inertia.

Technical Information

Technical Information

**Table 4.12 Reducer Moment of Inertia on Motor Shaft of Gearmotor: Hollow Output Shaft, Ratios 60 - 305<sup>(1)</sup>**  
Units: lb·in<sup>2</sup> (x 10<sup>-4</sup> kg·m<sup>2</sup>)

Model	Nominal Reduction Ratio												
	60	67	74	80	88	102	112	123	151	179	207	249	305
<b>4A100</b>	0.101	0.107	0.104	0.094	0.092	0.064	0.059	0.058	0.053	0.070	0.047	0.067	0.045
<b>4A105</b>	(0.297)	(0.314)	(0.306)	(0.275)	(0.270)	(0.188)	(0.172)	(0.169)	(0.154)	(0.206)	(0.138)	(0.196)	(0.131)
<b>4A110</b>	0.260	0.227	0.225	0.217	0.215	0.207	0.197	0.196	0.191	0.185	0.183	0.181	0.179
<b>4A115</b>	(0.760)	(0.665)	(0.657)	(0.634)	(0.628)	(0.605)	(0.577)	(0.575)	(0.559)	(0.541)	(0.536)	(0.529)	(0.525)
<b>4A120</b>	0.441	0.496	0.493	0.455	0.453	0.320	0.303	0.302	0.286	0.396	0.272	0.384	0.261
<b>4A125</b>	(1.29)	(1.45)	(1.44)	(1.33)	(1.33)	(0.935)	(0.887)	(0.884)	(0.838)	(1.16)	(0.795)	(1.12)	(0.763)
<b>4A140</b>	1.03	0.876	0.873	0.814	0.812	0.745	0.720	0.719	0.673	0.655	0.654	0.637	0.633
<b>4A145</b>	(3.01)	(2.56)	(2.56)	(2.38)	(2.38)	(2.18)	(2.11)	(2.10)	(1.97)	(1.92)	(1.91)	(1.86)	(1.85)
<b>4B120</b>	0.484	0.528	0.521	0.478	0.473	0.334	0.315	0.312	0.293	0.401	0.275	0.387	0.262
<b>4B125</b>	(1.42)	(1.54)	(1.52)	(1.40)	(1.38)	(0.978)	(0.921)	(0.913)	(0.857)	(1.17)	(0.805)	(1.13)	(0.768)
<b>4B140</b>	1.07	0.911	0.904	0.838	0.833	0.761	0.732	0.730	0.680	0.660	0.658	0.639	0.635
<b>4B145</b>	(3.14)	(2.67)	(2.65)	(2.45)	(2.44)	(2.23)	(2.14)	(2.14)	(1.99)	(1.93)	(1.93)	(1.87)	(1.86)
<b>4B160</b>	2.92	2.66	2.65	2.48	2.47	2.19	2.10	2.10	2.01	1.97	1.98	1.89	1.86
<b>4B165</b>	(8.53)	(7.79)	(7.77)	(7.25)	(7.23)	(6.41)	(6.15)	(6.14)	(5.88)	(5.77)	(5.80)	(5.54)	(5.46)
<b>4C140</b>	1.21	1.02	0.993	0.912	0.896	0.807	0.770	0.762	0.701	0.675	0.669	0.647	0.640
<b>4C145</b>	(3.54)	(2.97)	(2.91)	(2.67)	(2.62)	(2.36)	(2.25)	(2.23)	(2.05)	(1.98)	(1.96)	(1.89)	(1.87)
<b>4C160</b>	3.04	2.76	2.74	2.55	2.53	2.24	2.14	2.13	2.03	1.99	1.99	1.90	1.87
<b>4C165</b>	(8.91)	(8.08)	(8.02)	(7.46)	(7.41)	(6.54)	(6.26)	(6.23)	(5.94)	(5.81)	(5.83)	(5.56)	(5.47)
<b>4C170</b>	10.4	9.70	9.67	9.32	9.30	8.77	8.69	8.68	8.40	8.29	8.18	8.14	8.10
<b>4C175</b>	(30.5)	(28.4)	(28.3)	(27.3)	(27.2)	(25.7)	(25.4)	(25.4)	(24.6)	(24.3)	(23.9)	(23.8)	(23.7)
<b>4D160</b>	3.37	3.02	2.95	2.73	2.68	2.35	2.23	2.21	2.08	2.02	2.02	1.92	1.88
<b>4D165</b>	(9.86)	(8.85)	(8.64)	(8.00)	(7.85)	(6.87)	(6.53)	(6.46)	(6.09)	(5.92)	(5.90)	(5.62)	(5.51)
<b>4D170</b>	10.7	9.96	9.89	9.50	9.45	8.88	8.79	8.76	8.45	8.32	8.21	8.16	8.12
<b>4D175</b>	(31.4)	(29.1)	(28.9)	(27.8)	(27.7)	(26.0)	(25.7)	(25.6)	(24.7)	(24.4)	(24.0)	(23.9)	(23.8)
<b>4D180</b>	15.7	14.9	14.8	13.7	13.7	13.0	12.8	12.8	12.4	12.0	11.9	11.8	11.7
<b>4D185</b>	(46.0)	(43.5)	(43.3)	(40.1)	(40.0)	(38.0)	(37.4)	(37.4)	(36.2)	(35.2)	(34.9)	(34.6)	(34.4)
<b>4E170</b>	11.2	10.3	10.21	9.76	9.68	9.05	8.92	8.88	8.53	8.38	8.25	8.19	8.14
<b>4E175</b>	(32.9)	(30.2)	(29.9)	(28.6)	(28.3)	(26.5)	(26.1)	(26.0)	(25.0)	(24.5)	(24.1)	(24.0)	(23.8)
<b>4E180</b>	16.2	15.2	15.1	14.0	13.9	13.2	12.9	12.9	12.5	12.1	12.0	11.8	11.8
<b>4E185</b>	(47.4)	(44.5)	(44.2)	(40.9)	(40.7)	(38.5)	(37.8)	(37.7)	(36.5)	(35.3)	(35.0)	(34.7)	(34.4)
<b>4E190</b>	40.0	37.1	37.0	35.9	35.9	34.7	33.8	33.8	33.2	32.8	32.5	32.3	32.1
<b>4E195</b>	(117)	(109)	(108)	(105)	(105)	(102)	(98.9)	(98.8)	(97.1)	(96.0)	(95.2)	(94.6)	(94.1)
<b>4F180</b>	17.7	16.3	16.1	14.7	14.6	13.7	13.3	13.2	12.7	12.2	12.1	11.9	11.8
<b>4F185</b>	(51.9)	(47.7)	(47.1)	(43.1)	(42.7)	(40.0)	(38.9)	(38.7)	(37.2)	(35.8)	(35.4)	(34.9)	(34.6)
<b>4F190</b>	41.6	38.3	38.1	36.7	36.6	35.3	34.2	34.1	33.4	33.0	32.7	32.4	32.2
<b>4F195</b>	(122)	(112)	(111)	(108)	(107)	(103)	(100)	(99.9)	(97.9)	(96.6)	(95.6)	(94.9)	(94.3)

**Table 4.13 Reducer Moment of Inertia on Motor Shaft of Gearmotor: Solid Shaft [Left (L) or Right (R)] Output, Ratios 11 - 53<sup>(1)</sup>**  
Units: lb·in<sup>2</sup> (x 10<sup>-4</sup> kg·m<sup>2</sup>)

Model	Nominal Reduction Ratio												
	11	13	14	16	18	21	22	25	28	35	39	46	53
<b>4A100</b>	1.58	0.986	0.910	0.614	0.560	0.465	—	—	0.304	0.187	0.177	0.163	0.142
<b>4A105</b>	(4.64)	(2.88)	(2.66)	(1.80)	(1.64)	(1.36)	—	—	(0.890)	(0.547)	(0.517)	(0.477)	(0.415)
<b>4A100</b>	—	—	—	—	—	0.713	—	—	0.492	0.359	0.349	0.305	0.278
<b>4A115</b>	—	—	—	—	—	(2.09)	—	—	(1.44)	(1.05)	(1.02)	(0.893)	(0.814)
<b>4A120</b>	3.88	2.36	2.29	1.71	1.66	1.28	1.44	1.42	0.988	0.610	0.599	0.632	0.589
<b>4A125</b>	(11.3)	(6.92)	(6.69)	(5.01)	(4.85)	(3.75)	(4.22)	(4.15)	(2.89)	(1.78)	(1.75)	(1.85)	(1.72)
<b>4A140</b>	8.34	5.31	5.23	3.77	3.72	3.37	3.48	3.45	2.27	1.61	1.60	1.29	1.16
<b>4A145</b>	(24.4)	(15.5)	(15.3)	(11.0)	(10.9)	(9.88)	(10.2)	(10.1)	(6.65)	(4.71)	(4.68)	(3.78)	(3.40)
<b>4B120</b>	5.30	3.28	3.09	2.32	2.19	1.64	1.74	1.68	1.19	0.731	0.705	0.708	0.646
<b>4B125</b>	(15.5)	(9.61)	(9.03)	(6.80)	(6.42)	(4.79)	(5.10)	(4.91)	(3.48)	(2.14)	(2.06)	(2.07)	(1.89)
<b>4B120</b>	9.75	3.91	3.72	4.40	4.27	3.76	3.80	3.74	2.49	1.74	1.72	1.37	1.22
<b>4B125</b>	(28.5)	(11.4)	(10.9)	(12.9)	(12.5)	(11.0)	(11.1)	(10.9)	(7.29)	(5.10)	(5.02)	(4.02)	(3.58)
<b>4B140</b>	27.7	17.8	17.7	12.2	12.0	8.95	10.1	10.0	6.18	4.42	4.39	3.87	3.47
<b>4B145</b>	(81.2)	(52.2)	(51.7)	(35.6)	(35.2)	(26.2)	(29.5)	(29.4)	(18.1)	(12.9)	(12.8)	(11.3)	(10.1)
<b>4B160</b>	13.8	9.10	8.47	6.26	5.85	4.87	4.76	4.55	3.12	2.13	2.05	1.61	1.40
<b>4B165</b>	(40.5)	(26.6)	(24.8)	(18.3)	(17.1)	(14.3)	(13.9)	(13.3)	(9.12)	(6.23)	(5.99)	(4.71)	(4.10)
<b>4C160</b>	32.0	12.4	11.8	14.0	13.6	10.0	11.0	10.8	6.77	4.79	4.70	4.09	3.63
<b>4C165</b>	(93.7)	(36.4)	(34.5)	(41.0)	(39.9)	(29.3)	(32.2)	(31.6)	(19.8)	(14.0)	(13.8)	(12.0)	(10.6)
<b>4C170</b>	55.1	35.1	34.5	26.4	26.0	23.9	23.4	23.2	17.6	13.3	13.2	12.3	10.9
<b>4C175</b>	(161)	(103)	(101)	(77.3)	(76.1)	(69.9)	(68.4)	(67.8)	(51.4)	(38.9)	(38.7)	(36.1)	(31.9)
<b>4D160</b>	—	—	—	—	—	12.6	13.4	12.7	8.25	5.76	5.49	4.65	4.06
<b>4D165</b>	—	—	—	—	—	(37.0)	(39.2)	(37.3)	(24.1)	(16.8)	(16.1)	(13.6)	(11.9)
<b>4D170</b>	68.7	27.4	25.4	32.4	31.2	26.6	25.8	25.1	19.1	14.3	14.0	12.9	11.3
<b>4D175</b>	(201)	(80.1)	(74.4)	(94.9)	(91.2)	(77.7)	(75.5)	(73.6)	(55.8)	(41.8)	(41.0)	(37.8)	(33.2)
<b>4D180</b>	104	53.0	51.1	36.6	35.2	36.7	31.6	30.9	26.5	21.5	21.2	18.9	16.7
<b>4D185</b>	(305)	(155)	(150)	(107)	(103)	(107)	(92.4)	(90.5)	(77.6)	(62.9)	(62.1)	(55.4)	(48.8)
<b>4E170</b>	—	—	—	—	—	30.7	29.1	28.2	21.4	15.6	15.2	13.8	12.0
<b>4E175</b>	—	—	—	—	—	(89.7)	(85.2)	(82.4)	(62.6)	(45.7)	(44.6)	(40.4)	(35.1)
<b>4E180</b>	121	48.3	45.4	43.4	41.4	40.8	34.9	33.9	28.8	22.8	22.5	19.8	17.3
<b>4E185</b>	(353)	(141)	(133)	(127)	(121)	(119)	(102)	(99.3)	(84.3)	(66.9)	(65.7)	(58.0)	(50.7)
<b>4E190</b>	189	103	100	71.1	69.1	77.2	65.1	64.1	56.8	48.6	48.2	44.3	41.9
<b>4E195</b>	(553)	(301)	(293)	(208)	(202)	(226)	(191)	(188)	(166)	(142)	(141)	(130)	(123)
<b>4F180</b>	180	76.9	71.9	69.4	65.9	53.4	44.8	43.1	35.9	26.9	26.2	22.5	19.3
<b>4F185</b>	(528)	(225)	(210)	(203)	(193)	(156)	(131)	(126)	(105)	(78.6)	(76.6)	(65.8)	(56.5)
<b>4F190</b>	236	132	127	92.0	88.5	90.5	75.7	74.0	64.4	52.8	52.2	47.1	44.1
<b>4F195</b>	(692)	(388)	(373)	(269)	(259)	(265)	(221)	(216)	(188)	(155)	(153)	(138)	(129)

Note: (1) The inertia tables does not include the inertia of the integral motors. Total unit inertia is obtained by adding the reducer inertia to the motor inertia.

Note: (1) The inertia tables does not include the inertia of the integral motors. Total unit inertia is obtained by adding the reducer inertia to the motor inertia.



**Table 4.14 Reducer Moment of Inertia on Motor Shaft of Gearmotor: Solid Shaft [Left (L) or Right (R)] Output, Ratios 60 - 305<sup>(1)</sup>**  
Units: lb·in<sup>2</sup> (x 10<sup>-4</sup> kg·m<sup>2</sup>)

Model	Nominal Reduction Ratio												
	60	67	74	80	88	102	112	123	151	179	207	249	305
<b>4A100</b>	0.102	0.108	0.105	0.094	0.092	0.064	0.060	0.058	0.053	0.070	0.047	0.067	0.045
<b>4A105</b>	(0.298)	(0.315)	(0.307)	(0.276)	(0.270)	(0.188)	(0.175)	(0.169)	(0.155)	(0.206)	(0.138)	(0.196)	(0.131)
<b>4A110</b>	0.260	0.228	0.225	0.217	0.215	0.207	0.197	0.196	0.191	0.185	0.183	0.181	0.179
<b>4A115</b>	(0.761)	(0.666)	(0.658)	(0.635)	(0.629)	(0.605)	(0.578)	(0.575)	(0.559)	(0.541)	(0.536)	(0.529)	(0.525)
<b>4A120</b>	0.441	0.496	0.493	0.456	0.454	0.320	0.303	0.302	0.286	0.396	0.272	0.384	0.261
<b>4A125</b>	(1.29)	(1.45)	(1.44)	(1.33)	(1.33)	(0.936)	(0.887)	(0.884)	(0.838)	(1.159)	(0.795)	(1.125)	(0.763)
<b>4A140</b>	1.03	0.877	0.874	0.814	0.812	0.745	0.720	0.719	0.673	0.655	0.654	0.637	0.633
<b>4A145</b>	(3.01)	(2.57)	(2.56)	(2.38)	(2.38)	(2.18)	(2.11)	(2.10)	(1.97)	(1.92)	(1.91)	(1.86)	(1.85)
<b>4B120</b>	0.486	0.529	0.522	0.479	0.474	0.335	0.317	0.313	0.293	0.401	0.275	0.387	0.262
<b>4B125</b>	(1.42)	(1.55)	(1.53)	(1.40)	(1.39)	(0.98)	(0.93)	(0.91)	(0.86)	(1.17)	(0.81)	(1.13)	(0.768)
<b>4B140</b>	1.08	0.912	0.905	0.839	0.834	0.761	0.733	0.730	0.680	0.660	0.658	0.639	0.635
<b>4B145</b>	(3.15)	(2.67)	(2.65)	(2.46)	(2.44)	(2.23)	(2.14)	(2.14)	(1.99)	(1.93)	(1.93)	(1.87)	(1.86)
<b>4B160</b>	2.92	2.66	2.66	2.48	2.47	2.19	2.10	2.10	2.01	1.97	1.98	1.89	1.86
<b>4B165</b>	(8.54)	(7.79)	(7.77)	(7.25)	(7.24)	(6.41)	(6.15)	(6.14)	(5.88)	(5.77)	(5.80)	(5.54)	(5.46)
<b>4C140</b>	1.21	1.02	0.996	0.914	0.898	0.809	0.776	0.763	0.702	0.675	0.670	0.647	0.640
<b>4C145</b>	(3.55)	(2.98)	(2.91)	(2.68)	(2.63)	(2.37)	(2.27)	(2.23)	(2.05)	(1.98)	(1.96)	(1.89)	(1.87)
<b>4C160</b>	3.05	2.77	2.74	2.55	2.53	2.24	2.14	2.13	2.03	1.99	1.99	1.90	1.87
<b>4C165</b>	(8.92)	(8.09)	(8.03)	(7.46)	(7.41)	(6.55)	(6.26)	(6.24)	(5.94)	(5.81)	(5.83)	(5.56)	(5.47)
<b>4C170</b>	10.4	9.70	9.68	9.32	9.30	8.77	8.69	8.68	8.40	8.29	8.18	8.14	8.10
<b>4C175</b>	(30.5)	(28.4)	(28.3)	(27.3)	(27.2)	(25.7)	(25.4)	(25.4)	(24.6)	(24.3)	(23.9)	(23.8)	(23.7)
<b>4D160</b>	3.38	3.03	2.96	2.74	2.69	2.35	2.24	2.21	2.08	2.02	2.02	1.92	1.88
<b>4D165</b>	(9.88)	(8.87)	(8.65)	(8.01)	(7.86)	(6.88)	(6.56)	(6.46)	(6.09)	(5.92)	(5.91)	(5.62)	(5.51)
<b>4D170</b>	10.7	9.97	9.89	9.51	9.46	8.88	8.79	8.76	8.45	8.32	8.21	8.16	8.12
<b>4D175</b>	(31.5)	(29.2)	(29.0)	(27.8)	(27.7)	(26.0)	(25.7)	(25.6)	(24.7)	(24.4)	(24.0)	(23.9)	(23.8)
<b>4D180</b>	15.7	14.9	14.8	13.7	13.7	13.0	12.8	12.8	12.4	12.0	11.9	11.8	11.7
<b>4D185</b>	(46.0)	(43.5)	(43.3)	(40.2)	(40.0)	(38.0)	(37.4)	(37.4)	(36.2)	(35.2)	(34.9)	(34.6)	(34.4)
<b>4E170</b>	11.3	10.3	10.2	9.77	9.69	9.06	8.94	8.88	8.53	8.38	8.25	8.19	8.14
<b>4E175</b>	(33.0)	(30.3)	(29.9)	(28.6)	(28.4)	(26.5)	(26.2)	(26.0)	(25.0)	(24.5)	(24.1)	(24.0)	(23.8)
<b>4E180</b>	16.2	15.2	15.1	14.0	13.9	13.2	12.9	12.9	12.5	12.1	12.0	11.8	11.8
<b>4E185</b>	(47.5)	(44.6)	(44.3)	(40.9)	(40.7)	(38.5)	(37.8)	(37.7)	(36.5)	(35.3)	(35.1)	(34.7)	(34.4)
<b>4E190</b>	40.0	37.1	37.0	35.9	35.9	34.8	33.8	33.8	33.2	32.8	32.5	32.3	32.1
<b>4E195</b>	(117)	(109)	(108)	(105)	(105)	(102)	(98.9)	(98.8)	(97.1)	(96.0)	(95.2)	(94.6)	(94.1)
<b>4F180</b>	17.8	16.3	16.2	14.8	14.6	13.7	13.3	13.3	12.7	12.2	12.1	11.9	11.8
<b>4F185</b>	(52.1)	(47.8)	(47.3)	(43.2)	(42.8)	(40.1)	(39.0)	(38.8)	(37.2)	(35.8)	(35.4)	(34.9)	(34.6)
<b>4F190</b>	41.7	38.3	38.1	36.8	36.6	35.3	34.2	34.2	33.4	33.0	32.7	32.4	32.2
<b>4F195</b>	(122)	(112)	(112)	(108)	(107)	(103)	(100)	(99.9)	(97.9)	(96.6)	(95.6)	(94.9)	(94.3)

**Table 4.15 Reducer Moment of Inertia on Motor Shaft of Gearmotor: Dual Extended Solid Shaft (T) Output, Ratios 11 - 53<sup>(1)</sup>**  
Units: lb·in<sup>2</sup> (x 10<sup>-4</sup> kg·m<sup>2</sup>)

Model	Nominal Reduction Ratio													
	11	13	14	16	18	21	22	25	28	35	39	46	53	
<b>4A100</b>	1.65	1.03	0.947	0.645	0.586	0.482	—	—	0.313	0.193	0.182	0.166	0.145	
<b>4A105</b>	(4.83)	(3.01)	(2.77)	(1.89)	(1.72)	(1.41)	—	—	(0.917)	(0.565)	(0.532)	(0.487)	(0.423)	
<b>4A100</b>	—	—	—	—	—	0.730	—	—	0.502	0.365	0.354	0.309	0.281	
<b>4A115</b>	—	—	—	—	—	(2.14)	—	—	(1.47)	(1.07)	(1.03)	(0.903)	(0.822)	
<b>4A120</b>	3.47	2.41	2.32	1.74	1.68	1.30	1.46	1.43	0.997	0.616	0.604	0.635	0.592	
<b>4A125</b>	(10.2)	(7.05)	(6.80)	(5.09)	(4.93)	(3.80)	(4.27)	(4.18)	(2.92)	(1.80)	(1.77)	(1.86)	(1.73)	
<b>4A140</b>	7.29	5.35	5.27	3.80	3.75	3.39	3.48	3.46	2.28	1.62	1.61	1.29	1.17	
<b>4A145</b>	(21.3)	(15.7)	(15.4)	(11.1)	(11.0)	(9.93)	(10.2)	(10.1)	(6.68)	(4.73)	(4.70)	(3.79)	(3.41)	
<b>4B120</b>	5.46	3.39	3.17	2.40	2.25	1.68	1.78	1.71	1.21	0.745	0.717	0.716	0.652	
<b>4B125</b>	(16.0)	(9.92)	(9.29)	(7.01)	(6.59)	(4.91)	(5.20)	(5.00)	(3.54)	(2.18)	(2.10)	(2.09)	(1.91)	
<b>4B120</b>	9.90	6.36	6.15	4.47	4.33	3.80	3.84	3.76	2.51	1.76	1.73	1.38	1.23	
<b>4B125</b>	(29.0)	(18.6)	(18.0)	(13.1)	(12.7)	(11.1)	(11.2)	(11.0)	(7.36)	(5.14)	(5.06)	(4.04)	(3.60)	
<b>4B140</b>	23.9	18.0	17.7	12.2	12.1	9.0	10.1	10.1	6.20	4.43	4.40	3.88	3.47	
<b>4B145</b>	(70.0)	(52.5)	(51.9)	(35.8)	(35.4)	(26.3)	(29.6)	(29.4)	(18.1)	(13.0)	(12.9)	(11.3)	(10.2)	
<b>4B160</b>	14.2	9.34	8.68	6.42	5.98	4.96	4.84	4.62	3.17	2.16	2.07	1.63	1.42	
<b>4B165</b>	(41.5)	(27.3)	(25.4)	(18.8)	(17.5)	(14.5)	(14.2)	(13.5)	(9.27)	(6.33)	(6.07)	(4.77)	(4.15)	
<b>4C160</b>	32.4	21.1	20.4	14.2	13.8	10.1	11.1	10.9	6.82	4.82	4.73	4.11	3.65	
<b>4C165</b>	(94.8)	(61.8)	(59.8)	(41.5)	(40.3)	(29.5)	(32.5)	(31.8)	(20.0)	(14.1)	(13.8)	(12.0)	(10.7)	
<b>4C170</b>	47.8	35.3	34.7	26.6	26.2	24.0	23.5	23.2	17.6	13.3	13.2	12.4	10.9	
<b>4C175</b>	(140)	(103)	(102)	(77.8)	(76.5)	(70.2)	(68.7)	(68.0)	(51.6)	(39.0)	(38.7)	(36.2)	(32.0)	
<b>4D160</b>	—	—	—	—	—	12.8	13.6	12.9	8.36	5.83	5.55	4.70	4.09	
<b>4D165</b>	—	—	—	—	—	(37.6)	(39.7)	(37.7)	(24.5)	(17.0)	(16.2)	(13.7)	(12.0)	
<b>4D170</b>	69.5	44.8	42.8	32.8	31.4	26.8	25.8	25.3	19.2	14.3	14.1	13.0	11.4	
<b>4D175</b>	(203)	(131)	(125)	(95.9)	(92.0)	(78.3)	(75.6)	(74.0)	(56.2)	(42.0)	(41.2)	(37.9)	(33.3)	
<b>4D180</b>	82.7	53.5	51.5	36.9	35.5	36.9	31.7	31.1	26.6	21.6	21.3	19.0	16.7	
<b>4D185</b>	(242)	(157)	(151)	(108)	(104)	(108)	(92.9)	(90.9)	(77.9)	(63.1)	(62.3)	(55.5)	(48.8)	
<b>4E170</b>	—	—	—	—	—	31.0	29.5	28.4	21.6	15.8	15.3	13.9	12.1	
<b>4E175</b>	—	—	—	—	—	(90.9)	(86.2)	(83.2)	(63.2)	(46.1)	(44.9)	(40.6)	(35.3)	
<b>4E180</b>	122	63.8	60.7	44.1	42.0	41.2	35.3	34.2	29.0	23.0	22.6	19.9	17.4	
<b>4E185</b>	(358)	(187)	(178)	(129)	(123)	(121)	(103)	(100)	(85.0)	(67.3)	(66.0)	(58.2)	(50.9)	
<b>4E190</b>	153	104	101	71.8	69.7	77.5	65.4	64.4	57.0	48.7	48.3	44.4	42.0	
<b>4E195</b>	(446)	(304)	(295)	(210)	(204)	(227)	(192)	(188)	(167)	(143)	1(41)	(130)	(123)	
<b>4F180</b>	182	100	95.1	70.3	66.6	53.9	46.1	43.5	36.2	27.0	26.3	22.6	19.4	
<b>4F185</b>	(534)	(293)	(278)	(206)	(195)	(158)	(135)	(127)	(106)	(79.1)	(77.1)	(66.1)	(56.8)	
<b>4F190</b>	200	134	129	92.9	89.2	91.0	76.1	74.3	64.6	53.0	52.3	47.2	44.1	
<b>4F195</b>	(587)	(391)	(376)	(272)	(261)	(266)	(223)	(218)	(189)	(155)	(153)	(138)	(129)	

Note: (1) The inertia tables does not include the inertia of the integral motors. Total unit inertia is obtained by adding the reducer inertia to the motor inertia.

Note: (1) The inertia tables does not include the inertia of the integral motors. Total unit inertia is obtained by adding the reducer inertia to the motor inertia.

**Table 4.16 Reducer Moment of Inertia on Motor Shaft of Gearmotor: Dual Extended Solid Shaft (T) Output, Ratios 60 - 305<sup>[1]</sup>**  
Units: lb-in<sup>2</sup> (x 10<sup>-4</sup> kg-m<sup>2</sup>)

Model	Nominal Reduction Ratio												
	60	67	74	80	88	102	112	123	151	179	207	249	305
<b>4A100</b>	0.104	0.109	0.106	0.095	0.093	0.065	0.059	0.058	0.053	0.071	0.047	0.067	0.045
<b>4A105</b>	(0.304)	(0.320)	(0.311)	(0.279)	(0.273)	(0.191)	(0.174)	(0.171)	(0.156)	(0.207)	(0.139)	(0.197)	(0.131)
<b>4A110</b>	0.262	0.229	0.226	0.218	0.216	0.208	0.198	0.197	0.191	0.185	0.183	0.181	0.180
<b>4A115</b>	(0.767)	(0.671)	(0.662)	(0.638)	(0.632)	(0.607)	(0.579)	(0.576)	(0.560)	(0.541)	(0.537)	(0.530)	(0.526)
<b>4A120</b>	0.443	0.498	0.495	0.457	0.455	0.321	0.304	0.303	0.287	0.396	0.272	0.384	0.261
<b>4A125</b>	(1.30)	(1.46)	(1.45)	(1.34)	(1.33)	(0.938)	(0.889)	(0.886)	(0.839)	(1.16)	(0.795)	(1.13)	(0.763)
<b>4A140</b>	1.03	0.878	0.875	0.815	0.813	0.745	0.720	0.719	0.673	0.655	0.654	0.637	0.633
<b>4A145</b>	(3.01)	(2.57)	(2.56)	(2.39)	(2.38)	(2.18)	(2.11)	(2.10)	(1.97)	(1.92)	(1.92)	(1.86)	(1.85)
<b>4B120</b>	0.490	0.533	0.525	0.482	0.476	0.337	0.317	0.314	0.294	0.401	0.276	0.387	0.263
<b>4B125</b>	(1.44)	(1.56)	(1.54)	(1.41)	(1.39)	(0.985)	(0.926)	(0.918)	(0.860)	(1.18)	(0.807)	(1.13)	(0.769)
<b>4B140</b>	1.08	0.916	0.909	0.842	0.836	0.763	0.734	0.731	0.681	0.661	0.659	0.640	0.635
<b>4B145</b>	(3.16)	(2.68)	(2.66)	(2.46)	(2.45)	(2.23)	(2.15)	(2.14)	(1.99)	(1.93)	(1.93)	(1.87)	(1.86)
<b>4B160</b>	2.92	2.67	2.66	2.48	2.48	2.19	2.10	2.10	2.01	1.97	1.98	1.89	1.86
<b>4B165</b>	(8.55)	(7.81)	(7.78)	(7.26)	(7.24)	(6.42)	(6.16)	(6.15)	(5.88)	(5.77)	(5.80)	(5.54)	(5.46)
<b>4C140</b>	1.23	1.03	1.00	0.921	0.903	0.813	0.774	0.765	0.704	0.677	0.671	0.648	0.640
<b>4C145</b>	(3.59)	(3.01)	(2.94)	(2.69)	(2.64)	(2.38)	(2.27)	(2.24)	(2.06)	(1.98)	(1.96)	(1.90)	(1.87)
<b>4C160</b>	3.06	2.77	2.75	2.56	2.54	2.24	2.14	2.13	2.03	1.99	1.99	1.90	1.87
<b>4C165</b>	(8.96)	(8.12)	(8.05)	(7.48)	(7.43)	(6.56)	(6.27)	(6.24)	(5.94)	(5.82)	(5.83)	(5.56)	(5.47)
<b>4C170</b>	10.4	9.71	9.68	9.33	9.31	8.77	8.70	8.69	8.40	8.29	8.18	8.14	8.11
<b>4C175</b>	(30.5)	(28.4)	(28.3)	(27.3)	(27.2)	(25.7)	(25.4)	(25.4)	(24.6)	(24.3)	(23.9)	(23.8)	(23.7)
<b>4D160</b>	3.40	3.05	2.97	2.75	2.70	2.36	2.24	2.21	2.08	2.03	2.02	1.92	1.88
<b>4D165</b>	(9.95)	(8.93)	(8.70)	(8.05)	(7.89)	(6.90)	(6.56)	(6.48)	(6.10)	(5.93)	(5.91)	(5.62)	(5.51)
<b>4D170</b>	10.8	9.99	9.91	9.52	9.47	8.89	8.80	8.77	8.45	8.33	8.21	8.16	8.12
<b>4D175</b>	(31.5)	(29.2)	(29.0)	(27.9)	(27.7)	(26.0)	(25.7)	(25.7)	(24.7)	(24.4)	(24.0)	(23.9)	(23.8)
<b>4D180</b>	15.7	14.9	14.8	13.7	13.7	13.0	12.8	12.8	12.4	12.0	11.9	11.8	11.7
<b>4D185</b>	(46.1)	(43.6)	(43.3)	(40.2)	(40.0)	(38.0)	(37.5)	(37.4)	(36.2)	(35.2)	(34.9)	(34.6)	(34.4)
<b>4E170</b>	11.3	10.4	10.3	9.80	9.72	9.08	8.94	8.89	8.54	8.39	8.25	8.19	8.14
<b>4E175</b>	(33.1)	(30.4)	(30.0)	(28.7)	(28.4)	(26.6)	(26.2)	(26.0)	(25.0)	(24.5)	(24.2)	(24.0)	(23.8)
<b>4E180</b>	16.3	15.3	15.2	14.0	13.9	13.2	12.9	12.9	12.5	12.1	12.0	11.9	11.8
<b>4E185</b>	(47.7)	(44.7)	(44.4)	(41.0)	(40.8)	(38.6)	(37.9)	(37.7)	(36.5)	(35.4)	(35.1)	(34.7)	(34.4)
<b>4E190</b>	40.1	37.2	37.1	36.0	35.9	34.8	33.8	33.8	33.2	32.8	32.5	32.3	32.1
<b>4E195</b>	(117)	(109)	(108)	(105)	(105)	(102)	(98.9)	(98.8)	(97.1)	(96.0)	(95.2)	(94.6)	(94.1)
<b>4F180</b>	17.9	16.4	16.2	14.8	14.7	13.7	13.3	13.3	12.7	12.3	12.1	11.9	11.8
<b>4F185</b>	(52.3)	(48.0)	(47.4)	(43.3)	(42.9)	(40.2)	(39.0)	(38.8)	(37.2)	(35.9)	(35.4)	(34.9)	(34.6)
<b>4F190</b>	41.7	38.4	38.2	36.8	36.7	35.4	34.2	34.2	33.5	33.0	32.7	32.4	32.2
<b>4F195</b>	(122)	(112)	(112)	(108)	(107)	(103)	(100)	(100.0)	(97.9)	(96.6)	(95.6)	(94.9)	(94.3)

Note: (1) The inertia tables does not include the inertia of the integral motors. Total unit inertia is obtained by adding the reducer inertia to the motor inertia.

**Table 4.17a Moment of Inertia on Motor Shaft of V-Frame Integral Motor** Units: lb-inch<sup>2</sup> (x 10<sup>-4</sup> kg-m<sup>2</sup>)

1/8 HP (0.1 kW) x 4 Pole		1/4 HP (0.2 kW) x 4 Pole		1/3 HP (0.25 kW) x 4 Pole		1/2 HP (0.4 kW) x 4 Pole		3/4 HP (0.55 kW) x 4 Pole	
Standard	w/ Brake	Standard	w/Brake	Standard	w/Brake	Standard	w/Brake	Standard	w/Brake
1.11	1.2	1.71	1.88	1.71	1.88	2.22	2.31	3.45	3.79
(3.25)	(3.5)	(5)	(5.5)	(5)	(5.5)	(6.5)	(6.75)	(10.1)	(11.1)

**Table 4.17b Moment of Inertia on Motor Shaft of V-Frame AF Integral Motor**

1/8 HP (0.1 kW) x 4 Pole		1/4 HP (0.2 kW) x 4 Pole		1/3 HP (0.25 kW) x 4 Pole		1/2 HP (0.4 kW) x 4 Pole		3/4 HP (0.55 kW) x 4 Pole	
Standard	w/ Brake	Standard	w/Brake	Standard	w/Brake	Standard	w/Brake	Standard	w/Brake
1.71	1.88	2.22	2.31	2.22	2.31	4.1	4.44	6.32	7.11
(5)	(5.5)	(6.5)	(6.75)	(6.5)	(6.75)	(12)	(13)	(18.5)	(20.8)

**Table 4.17c Moment of Inertia on Motor Shaft of N-Frame Integral Motor**

1 HP (0.75 kW) x 4 Pole		1.5 HP (1.1 kW) x 4 Pole		2 HP (1.5 kW) x 4 Pole		3 HP (2.2 kW) x 4 Pole		5 HP (3.7 kW) x 4 Pole	
Standard	w/ Brake	Standard	w/Brake	Standard	w/Brake	Standard	w/Brake	Standard	w/Brake
8.03	8.82	11.5	13.5	13.4	15.4	30.1	33.4	66.3	71.4
(23.5)	(25.8)	(33.7)	(39.6)	(39.1)	(45)	(88)	(97.8)	(194)	(209)
7.5 HP (5.5 kW) x 4 Pole		10 HP (7.5 kW) x 4 Pole		15 HP (11 kW) x 4 Pole		20 HP (15 kW) x 4 Pole		25 HP (18.5 kW) x 4 Pole	
Standard	w/ Brake	Standard	w/ Brake	Standard	w/ Brake	Standard	w/ Brake	Standard	w/ Brake
99.4	105	140	154	192	206	340	393	875	926
(291)	(306)	(409)	(450)	(561)	(602)	(995)	(1150)	(2560)	(2710)
30 HP (22 kW) x 4 Pole		40 HP (30 kW) x 4 Pole		50 HP (37 kW) x 4 Pole		60 HP (45 kW) x 4 Pole		75 HP (55 kW) x 4 Pole	
Standard	w/ Brake	Standard	w/ Brake	Standard	w/ Brake	Standard	w/ Brake	Standard	w/ Brake
875	926	1110	1170	1330	1380	2500	2550	2950	-
(2560)	(2710)	(3260)	(3420)	(3900)	(4040)	(7310)	(7450)	(8640)	-

## Special Load Guidelines Misc.

### Excessive Overloads

Cyclo® BBB4 Speed Reducers provide 200% momentary intermittent shock load capacity and are warranted for two years from date of shipment. Refer to our standard terms and conditions for our complete warranty.

### Selection for Applications Involving Shock Loading

For applications involving frequent start-stop, review the recommendations in the selection procedure. For braking or reversing, or quick starting of loads having large inertia, consult factory for model selection or recommended modifications.

### Allowable Radial and Thrust Loads

The loads imposed on the reducer shafts vary with the method of connecting the shaft to the driven machine. Frequently, in addition to torsional forces, radial and thrust loads are applied to the slow speed shaft at the same time. For example, coupling connections normally involve torsional forces only. However, when power is transmitted through spur gears, belts, pulleys or chains, both torsional

and radial forces may be applied to the reducer shafts. When driving through helical or bevel gears, all three conditions (torsional, radial and thrust load) may be referred to the reducer shaft.

The reducer shafts and bearings must have sufficient strength to withstand these loads, and it is, therefore, necessary to determine the allowable limits for each condition. Please consult factory for further information.

### Load Centering

The radial load capacities are calculated with the load concentrated at the midpoint of the slow speed shaft extension. Radial load capacities decrease if the center of the load is moved farther from the reducer and the values obtained from the charts must be adjusted accordingly..

Technical Information

Technical Information

## Oil lubricated models are not filled with oil prior to shipping.

Before operating, fill the unit with the appropriate amount of the correct lubricant for the mounting position (see Table 4.22 and Table 4.23).

When operating in winter or other relatively low ambient temperatures, use the lower viscosity oil specified for each ambient temperature range.

Please consult the factory if the unit will be operated consistently in ambient temperatures other than 14°F to 104°F (-10° to 40°C).

## Grease lubricated models are lubricated with grease prior to shipment from the factory.

NOTE: For units supplied in the Y4 mounting position (input shaft vertical down), the Cyclo® portion is filled at the factory with grease. For these units, the Cyclo® portion does not need to be filled with lubricant before start-up. The Bevel Gear portion of models built for the Y4 mounting configuration still requires filling with gear oil before start-up. Refer to the unit Operating and Maintenance manual for further details.

Adding grease prior to initial start-up is not required. If grease must be replenished or changed avoid using greases other than those shown in the Table 4.20. Please consult the factory when the units will be used in widely fluctuating temperatures, ambient temperatures other than those specified in Table 4.20, or when other special conditions exist for the application. When motors from another manufacturer will be used, please consult and adhere to the associated motor maintenance manual for the appropriate lubrication instructions.

**Oil lubricated units** are shipped without oil. Prior to initial start-up, the unit must be filled with the correct amount of oil (see Table 4.22 and Table 4.23).

**Grease lubricated models** are lubricated at the factory. Additional grease does not need to be added prior to initial start-up.

## Oil Replenishment and Change Interval

- Maintain proper oil levels at all times.
- An oil change after the first 500 hours of operation is highly recommended.
- Sumitomo recommends an oil change every 2500 hours, or six months, whichever comes first. If a proper preventive maintenance program is implemented and maintained, a longer change period may be acceptable.
- For any operating conditions outside our standard (page xx), consult factory for recommendations.

## Grease Replenishment and Change Interval

For units ordered for mounting in the Y4 configuration (motor vertical down), please consult the Operating and Maintenance manual for proper grease replenishment and change interval for the Cyclo® portion.

\*VG68 is not available for ExxonMobil Spartan.

\*\*Shell Gadus S2 V220 NLGI 0 can be used for 4A100 and 4A105 sizes only

**Table 4.18 Lubrication Type**

Unit Size	Output (Bevel Gear Portion)	Input (Cyclo® Portion)		
		Motor Horizontal	Motor Vertical Up	Motor Vertical Down
All	Oil	Oil	Oil	Grease

### Approved Oils:

<b>ExxonMobil</b>	Spartan EP	<b>Idemitsu</b>	Daphne Super Gear Oil	<b>BP</b>	Energol GR-XP
<b>ExxonMobil</b>	Mobilgear 600XP	<b>Klüber</b>	Klüberoll GEM1	<b>Castrol</b>	Alpha SP
<b>ExxonMobil</b>	Mobil SHC Gear Hi-Shock 150	<b>Caltex</b>	Meropa	<b>Gulf Shell</b>	EP Lubricant HD Omala S2 G

**Table 4.19 Ambient Temperatures**

°F	14	32	50	68	86	104	122	
°C	-10	0	10	20	30	40	50	
ISO VG	68* (14° F to 41° F)							
	100 / 150 (32° F to 95° F)							
	220 / 320 / 460 (86° F to 122° F)							

**Food Grade Oil:** Klüber: Klübersynth UH1 6-460

**Table 4.20 Standard Greases**

Ambient Temperature °F (°C)	Reduction Ratio	Input (Cyclo® Portion)
14° to 122°F (-10° to 50°C)	11 through 18:1	N/A**
	19:1 and higher	Exxon Unirex N2

**Table 4.21 Food Grade Grease**

Ambient Temperature °F (°C)	Reduction Ratio	Input (Cyclo® Portion)
14° to 122°F (-10° to 50°C)	11 through 18:1	N/A
	19:1 and higher	Ultrachem Omnilube FGM2

## Oil Quantities

Be sure to check the oil level with the oil gauge. The following listed oil quantity is an approximation.

**Table 4.22 BBB with Single Reduction Cyclo - Approximate Oil Quantity**

Units: US liquid gallon (liter) **Note: Output = Bevel Gear Portion Input = Cyclo® Portion**

Bevel Gear Unit Size	Mounting Configuration						
	Y1	Y3	Y2	Y4	Y5	Y6	
4A10	0.43 (1.62)		0.86 (3.26)	0.30 (1.13)	Grease	0.36 (1.36)	0.49 (1.84)
4A11	0.44 (1.66)		0.89 (3.36)			0.37 (1.40)	0.50 (1.88)
4A12	0.45 (1.71)		0.93 (3.51)			0.38 (1.45)	0.51 (1.93)
4A14	0.50 (1.91)		1.08 (4.11)	0.45 (1.72)	Grease	0.44 (1.65)	0.56 (2.13)
4B12	0.87 (3.29)		1.74 (6.61)			0.88 (3.34)	0.85 (3.23)
4B14	0.92 (3.49)		1.93 (7.31)			0.94 (3.54)	0.91 (3.43)
4B16	1.04 (3.92)		2.06 (7.8)	0.72 (2.72)	Grease	1.05 (3.97)	1.02 (3.86)
4C14	1.46 (5.52)		3.01 (11.4)			1.40 (5.30)	1.55 (5.88)
4C16	1.57 (5.96)		3.18 (12)			1.52 (5.74)	1.67 (6.32)
4C17	1.67 (6.34)		3.37 (12.8)	1.22 (4.61)	Grease	1.62 (6.12)	1.77 (6.70)
4D16	2.66 (10.1)		5.32 (20.1)			2.56 (9.69)	2.76 (10.4)
4D17	2.75 (10.4)		5.48 (20.8)			2.65 (10.0)	2.85 (10.8)
4D18	2.83 (10.7)		5.62 (21.3)	1.66 (6.26)	Grease	2.72 (10.3)	2.93 (11.1)
4E17	3.85 (14.6)		7.73 (29.3)			3.45 (13.1)	4.24 (16.1)
4E18	3.88 (14.7)		7.85 (29.7)			3.49 (13.2)	4.28 (16.2)
4E19	4.14 (15.7)		8.24 (31.2)	1.92 (7.28)	Grease	3.75 (14.2)	4.54 (17.2)
4F18	5.28 (20.0)		10.6 (40.3)			4.89 (18.5)	5.65 (21.4)
4F19	5.50 (20.8)		10.9 (41.2)			5.10 (19.3)	5.86 (22.2)

**Table 4.23 BBB with Double Reduction Cyclo - Approximate Oil Quantity**

Units: US liquid gallon (liter) **Note: Output = Bevel Gear Portion Input = Cyclo® Portion**

Bevel Gear Unit Size	Mounting Configuration								
	Y1	Y3	Y2		Y4	Y5	Y6		
			Standard	Clear Cup					
4A10DA	0.44 (1.65)		0.26 (1.0)	Grease	0.30 (1.13)	Grease	0.37 (1.39)	0.49 (1.87)	
4A12DA	0.46 (1.74)						0.89 (3.38)	0.39 (1.48)	0.52 (1.96)
4A12DB	0.47 (1.78)						0.91 (3.46)	0.40 (1.52)	0.53 (2.00)
4B12DA	0.88 (3.32)		0.53 (2.0)	Grease	0.45 (1.72)	Grease	0.89 (3.37)	0.86 (3.26)	
4B12DB	0.89 (3.36)						1.74 (6.6)	0.90 (3.41)	0.87 (3.30)
4B14DA	0.93 (3.52)						1.85 (7.02)	0.94 (3.57)	0.91 (3.46)
4B14DB	0.94 (3.56)		1.86 (7.06)	0.95(3.61)	0.92 (3.50)	0.97(3.66)	0.94(3.55)		
4B14DC	0.95(3.61)		1.89 (7.17)						
4C14DA	1.47(5.55)		2.98 (11.3)					1.41 (5.33)	1.56 (5.91)
4C14DB	1.48 (5.59)		2.98 (11.3)						
4C14DC	1.49 (5.64)		3.01 (11.4)						
4C16DA	1.59 (6.03)		0.92 (3.5)	Grease	0.72 (2.72)	Grease	3.18 (12)	1.53 (5.81)	
4C16DB	1.61 (6.08)						3.2 (12.1)	1.55 (5.86)	1.70 (6.44)
4C17DA	1.69 (6.41)						3.38 (12.8)	1.63 (6.19)	1.79 (6.77)
4C17DB	1.70(6.44)		3.38 (12.8)	1.67(6.32)	1.80(6.80)	1.70(6.42)	1.82(6.90)		
4C17DC	1.75(6.64)		3.4 (12.9)						
4D16DA	2.68 (10.1)		5.34 (20.2)					2.58 (9.76)	2.77 (10.5)
4D16DB	2.69 (10.2)		5.34 (20.2)						
4D16DC	2.72(10.3)		5.37 (20.3)						
4D17DA	2.69(10.2)		1.32 (5.0)	Grease	1.22 (4.61)	Grease	5.33 (20.2)	2.59(9.81)	
4D17DB	2.78 (10.5)						5.49 (20.8)	2.68 (10.2)	2.88 (10.9)
4D17DC	2.82 (10.7)						5.52 (20.9)	2.72 (10.3)	2.91 (11.0)
4D18DA	2.85(10.8)		1.93 (7.3)	Grease	1.65 (6.26)	Grease	5.63 (21.3)	2.77(10.5)	
4D18DB	3.09(11.7)						5.71 (21.6)	3.01(11.4)	3.20(12.1)
4E17DA	3.86 (14.6)						7.73 (29.3)	3.47 (13.1)	4.26 (16.1)
4E17DB	3.88 (14.7)		7.75 (29.3)	3.48 (13.2)	4.27 (16.2)				
4E17DC	3.91 (14.8)		7.78 (29.5)						
4E18DA	3.9 (14.8)		7.9 (29.9)			3.52 (13.3)	4.31 (16.3)		
4E18DB	4.1 (15.7)		7.98 (30.2)	3.5 (13.3)	4.3 (16.3)				
4E19DA	4.6 (17.5)		8.4 (31.8)			3.8 (14.2)	4.5 (17.2)		
4E19DB	4.7 (17.7)		8.4 (31.8)			4.2 (16)	5 (19)		
4F18DA	5.3 (20.1)		10.7 (40.5)	4.3 (16.2)	5.1 (19.2)				
4F18DB	5.5 (21)		10.8 (40.8)			4.9 (18.6)	5.7 (21.5)		
4F19DA	6 (22.6)		11 (41.8)			5.2 (19.5)	5.9 (22.4)		
4F19DB	6 (22.8)		11 (41.8)	5.6 (21.3)	6.4 (24.2)				

Note: Polyalkylene Glycol (PAG)-based oil such as Klübersynth UH1 is not compatible, and cannot be used, with the clear polycarbonate fill cup.



# Motor Optional Conduit Box Location

**Table 4.24 - BBB4 Y1 Mounting**

Cable Port Direction	Terminal Box Mounting Position			
	Left Side (N33) (Viewed from Gearbox Side)	Right Side (N34) (Viewed from Gearbox Side)	Top Side (N35) (Viewed from Gearbox Side)	Bottom Side (N36) (Viewed from Gearbox Side)
Type A (N3A)				
Type B (N3B)				
Type C (N3C)				
Type D (N3D)				

**Table 4.25 - BBB4 Y2 Mounting**

Cable Port Direction	Terminal Box Mounting Position			
	Left Side (N33) (Viewed from Gearbox Side)	Right Side (N34) (Viewed from Gearbox Side)	Top Side (N35) (Viewed from Gearbox Side)	Bottom Side (N36) (Viewed from Gearbox Side)
Type A (N3A)				
Type B (N3B)				
Type C (N3C)				
Type D (N3D)				

Special consideration must be given to terminal box location N35 in mounting position Y2 if the unit is oil lubricated. The conduit box may interfere with the unit's oil plumbing system. Another conduit box location should be selected if possible. If location N35 must be used, consult the factory.

**NOTE:** Default Terminal Box position for Gearmotors is N33/ N3B for all mounting positions (Y1 thru Y6), as highlighted in grey.

←: The arrow indicates direction of lead wire out of conduit box.

# Motor Optional Conduit Box Location continued

**Table 4.26 - BBB4 Y3 Mounting**

Cable Port Direction	Terminal Box Mounting Position			
	Left Side (N33) (Viewed from Gearbox Side)	Right Side (N34) (Viewed from Gearbox Side)	Top Side (N35) (Viewed from Gearbox Side)	Bottom Side (N36) (Viewed from Gearbox Side)
Type A (N3A)				
Type B (N3B)				
Type C (N3C)				
Type D (N3D)				

**Table 4.27 - BBB4 Y4 Mounting**

Cable Port Direction	Terminal Box Mounting Position			
	Left Side (N33) (Viewed from Gearbox Side)	Right Side (N34) (Viewed from Gearbox Side)	Top Side (N35) (Viewed from Gearbox Side)	Bottom Side (N36) (Viewed from Gearbox Side)
Type A (N3A)				
Type B (N3B)				
Type C (N3C)				
Type D (N3D)				

Special consideration must be given to terminal box location N35 in mounting position Y2 if the unit is oil lubricated. The conduit box may interfere with the unit's oil plumbing system. Another conduit box location should be selected if possible. If location N35 must be used, consult the factory.

**NOTE:** Default Terminal Box position for Gearmotors is N33/ N3B for all mounting positions (Y1 thru Y6), as highlighted in grey.

←: The arrow indicates direction of lead wire out of conduit box.

Technical Information

Technical Information



**Table 4.28 - BBB4 Y5 Mounting**

Cable Port Direction	Terminal Box Mounting Position			
	Left Side (N33) (Viewed from Gearbox Side)	Right Side (N34) (Viewed from Gearbox Side)	Top Side (N35) (Viewed from Gearbox Side)	Bottom Side (N36) (Viewed from Gearbox Side)
Type A (N3A)				
Type B (N3B)				
Type C (N3C)				
Type D (N3D)				

**Table 4.29 - BBB4 Y6 Mounting**

Cable Port Direction	Terminal Box Mounting Position			
	Left Side (N33) (Viewed from Gearbox Side)	Right Side (N34) (Viewed from Gearbox Side)	Top Side (N35) (Viewed from Gearbox Side)	Bottom Side (N36) (Viewed from Gearbox Side)
Type A (N3A)				
Type B (N3B)				
Type C (N3C)				
Type D (N3D)				

Special consideration must be given to terminal box location N35 in mounting position Y2 if the unit is oil lubricated. The conduit box may interfere with the unit's oil plumbing system. Another conduit box location should be selected if possible. If location N35 must be used, consult the factory.

**NOTE:** Default Terminal Box position for Gearmotors is N33/ N3B for all mounting positions (Y1 thru Y6), as highlighted in grey.

←: The arrow indicates direction of lead wire out of conduit box.

## Motor Installation: Fan/Brake Cover Clearance Requirements

Required gearmotor clearance dimension FA and FB for installation to achieve best performance and proper maintenance.

**Dimension FA:** Clearance dimension necessary to remove fan cover or brake cover without removing the motor from the equipment.

**Dimension FB:** Minimum clearance to provide adequate ventilation.

**Notes:** 1. In some cases, it may be necessary to move the gearmotor to remove the fan cover or brake cover.

2. Dimension FB is the minimum clearance when the fan cover is up against a closed wall.

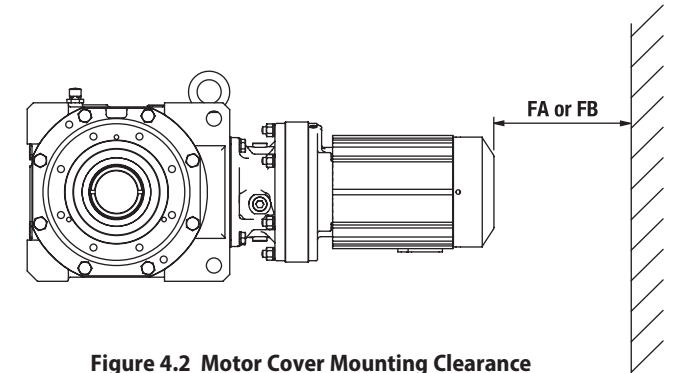

**Figure 4.2 Motor Cover Mounting Clearance**

**Table 4.30a Motor Clearance Requirements for Standard IE1 motors (1/8 to 3/4 hp)**

Units: inches (mm)

Frame Size	IE1 Motor		Standard 3-Phase Motor		3-Phase With Brake Motor	
	HP x Pole	kW x Pole	FA	FB	FA	FB
VA-63S	1/8 x 4	0.1 x 4	-	-	2.0 (49)	-
VA-63M	1/4 x 4	0.2 x 4	1.9 (48)	0.8 (20)	2.5 (61)	0.8 (20)
VA-63M	1/3 x 4	0.25 x 4				
VA-71M	1/2 x 4	0.4 x 4	1.9 (48)	0.8 (20)	2.5 (61)	0.8 (20)
VA-80S	3/4 x 4	0.55 x 4	2.0 (49)	0.8 (20)	3.7 (93)	0.8 (20)

**Table 4.30b Motor Clearance Requirements for AF - motors (1/8 to 3/4 hp)**

Units: inches (mm)

Frame Size	IE1 Motor		Standard 3-Phase Motor		3-Phase With Brake Motor	
	HP x Pole	kW x Pole	FA	FB	FA	FB
VA-63S	1/8 x 4	0.1 x 4				
VA-63M	1/4 x 4	0.2 x 4	1.9 (48)	0.8 (20)	2.5 (61)	0.8 (20)
VA-63M	1/3 x 4	0.25 x 4				
VA-71M	1/2 x 4	0.4 x 4	2 (49)	0.8 (20)	3.7 (93)	0.8 (20)
VA-80S	3/4 x 4	0.55 x 4	2.1 (52)	0.8 (20)	4.6 (115)	0.8 (20)

**Table 4.30c Motor Clearance Requirements for EP motors (1 to 75 hp)**

Units: inches (mm)

Frame Size	IE3 Motor		3-Phase Without Brake Motor		3-Phase Brake (B) Motor	
	HP x Pole	kW x Pole	FA	FB	FA	FB
N-80M	1 x 4	0.75 x 4	2.3 (58)	0.8 (20)	4.8 (122)	0.8 (20)
N-90S	1.5 x 4	1.1 x 4				
N-90L	2 x 4	1.5 x 4	2.3 (59)	0.8 (20)	5.0 (128)	0.8 (20)
N-100L	3 x 4	2.2 x 4	2.4 (60)	0.8 (20)	5.4 (138)	0.8 (20)
N-112M	5 x 4	3.7 x 4				
N-132S	7.5 x 4	5.5 x 4	2.5 (63)	1.0 (25)	6.0 (153)	0.8 (20)
N-132M	10 x 4	7.5 x 4				
N-160M	15 x 4	11 x 4	3.3 (84)	1.2 (30)	7.4 (189)	1 (25)
N-160L	20 x 4	15 x 4	4.2 (107)	1.2 (30)	9.5 (242)	1.2 (30)
N-180MS	25 x 4	18.5 x 4				
N-180M	30 x 4	22 x 4	5.3 (134)	1.2 (30)	12.1 (308)	1.2 (30)
N-180L	40 x 4	30 x 4				
N-200L	50 x 4	37 x 4	5.3 (134)	1.2 (30)	13.6 (345)	1.2 (30)
N-200LL	60 x 4	45 x 4	6.7 (171)	1.2 (30)	14.8 (376)	1.2 (30)

Motor Conduit Box Details

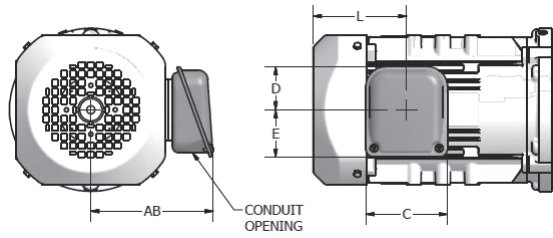

Figure 4.3 Indoor Duty (Optional) Box

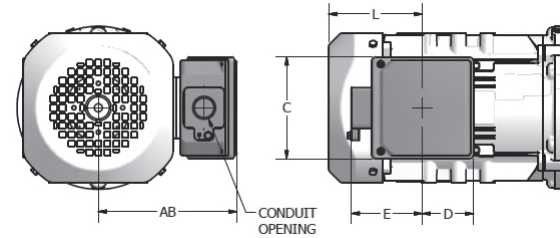

Figure 4.4 Global EP.NA and Outdoor Duty Box

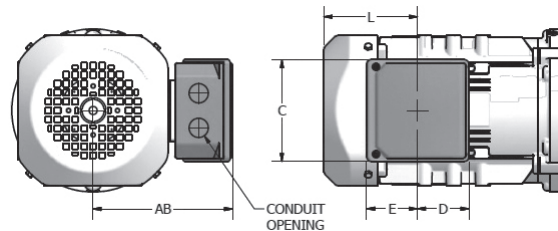

Figure 4.5 Global IE3 CE Box

Table 4.31 Conduit Box Information

Units: inches (mm)

Frame Size	Duty Rating	General Dimensions				Without Brake		With Brake		Conduit Opening	Material
		AB	C	D	E	Availability	L	Availability	L		
V-63S	Indoor Duty (Optional)	4.11 (105)	3.35 (85)	2.09 (53)	1.69 (43)	yes	1.38 (35)	CF <sup>(1)</sup>	2.76 (70)	Ø0.90 (Ø23)	Steel
	Indoor Duty Brake (Optional)	4.32 (110)	3.94 (100)	2.29 (58)	2.10 (53)			yes		Ø0.90 (Ø23)	Steel
	Outdoor Duty (Optional)	4.98 (127)	3.94 (100)	2.42 (62)	2.76 (70)			yes		NPT1/2 <sup>(2)</sup>	Steel
	Global	4.63 (118)	4.09 (104)	2.24 (57)	2.16 (55)			yes		NPT1/2	Al Diecast
	Global CE	4.63 (118)	4.09 (104)	2.24 (57)	2.16 (55)			yes		M16, M25	Al Diecast
VA-63S V-63M VA-63M V-71M	Indoor Duty (Optional)	4.11 (105)	3.35 (85)	2.09 (53)	1.69 (43)	yes	2.32 (59)	CF <sup>(1)</sup>	3.58 (91)	Ø0.90 (Ø23)	Steel
	Indoor Duty Brake (Optional)	4.32 (110)	3.94 (100)	2.29 (58)	2.10 (53)			yes		Ø0.90 (Ø23)	Steel
	Outdoor Duty (Optional)	4.98 (127)	3.94 (100)	2.42 (62)	2.76 (70)			yes		NPT1/2 <sup>(2)</sup>	Steel
	Global	4.63 (118)	4.09 (104)	2.24 (57)	2.16 (55)			yes		NPT1/2	Al Diecast
VA-71M V-80S	Indoor Duty (Optional)	4.69 (119)	3.35 (85)	1.72 (44)	2.04 (52)	yes	3.82 (97)	CF <sup>(1)</sup>	5.51 (140)	Ø0.90 (Ø23)	Steel
	Indoor Duty Brake (Optional)	5.68 (144)	4.80 (122)	2.60 (66)	2.84 (72)			yes		Ø0.90 (Ø23)	Steel
	Outdoor Duty (Optional)	5.55 (141)	3.94 (100)	2.20 (56)	2.95 (75)			yes		G3/4 <sup>(2)</sup>	Steel
	Global	5.67 (144)	4.92 (125)	2.50 (64)	3.43 (87)			yes		NPT3/4 <sup>(2)</sup>	Al Diecast
	Global CE	5.71 (145)	4.92 (125)	2.50 (64)	2.47 (63)			yes		2 - M25	Al Diecast
VA-80S	Indoor Duty (Optional)	4.88 (124)	3.35 (85)	1.72 (44)	2.04 (52)	yes	3.94 (100)	CF <sup>(1)</sup>	6.38 (162)	Ø0.90 (Ø23)	Steel
	Indoor Duty Brake (Optional)	5.87 (149)	4.80 (122)	2.60 (66)	2.84 (72)			yes		Ø0.90 (Ø23)	Steel
	Outdoor Duty (Optional)	5.75 (146)	3.94 (100)	2.20 (56)	2.95 (75)			yes		G3/4 <sup>(2)</sup>	Steel
	Global	5.86 (149)	4.92 (125)	2.50 (64)	3.43 (87)			yes		NPT3/4 <sup>(2)</sup>	Al Diecast
	Global CE	5.91 (150)	4.92 (125)	2.50 (64)	2.47 (63)			yes		2 - M25	Al Diecast

Table 4.31 Conduit Box Information (continued)

Units: inches (mm)

Frame Size	Duty Rating	General Dimensions				Without Brake		With Brake		Conduit Opening	Material
		AB	C	D	E	Availability	L	Availability	L		
N-80M	Indoor Duty (Optional)	4.85 (123)	3.35 (85)	1.72 (44)	2.04 (52)	Yes	3.82 (97)	CF <sup>(1)</sup>	6.32 (161)	Ø0.90 (Ø23)	Steel
	Indoor Duty Brake (Optional)	5.99 (152)	4.80 (122)	2.60 (66)	2.84 (72)			Yes		Ø0.90 (Ø23)	Steel
	Outdoor Duty (Optional)	5.87 (149)	3.94 (100)	2.20 (56)	2.95 (75)			Yes		G3/4 <sup>(2)</sup>	Steel
	Global EP.NA	5.98 (152)	4.92 (125)	2.50 (64)	3.43 (87)			Yes		NPT3/4 <sup>(2)</sup>	Al Diecast
	Global IE3 CE	6.02 (153)	4.92 (125)	2.50 (64)	2.47 (63)			Yes		2 - M25	Al Diecast
N-90S N-90L	Indoor Duty (Optional)	5.03 (128)	3.35 (85)	1.72 (44)	2.04 (52)	Yes	3.82 (97)	CF <sup>(1)</sup>	6.56 (167)	Ø0.90 (Ø23)	Steel
	Indoor Duty Brake (Optional)	6.17 (157)	4.80 (122)	2.60 (66)	2.84 (72)			Yes		Ø0.90 (Ø23)	Steel
	Outdoor Duty (Optional)	6.04 (154)	3.94 (100)	2.20 (56)	2.95 (75)			Yes		G3/4 <sup>(2)</sup>	Steel
	Global EP.NA	6.16 (156)	4.92 (125)	2.50 (64)	3.43 (87)			Yes		NPT3/4 <sup>(2)</sup>	Al Diecast
	Global IE3 CE	6.20 (158)	4.92 (125)	2.50 (64)	2.47 (63)			Yes		2 - M25	Al Diecast
N-100L N-112S	Indoor Duty (Optional)	5.93 (151)	3.94 (100)	2.09 (53)	2.29 (58)	Yes	4.53 (115)	CF <sup>(1)</sup>	7.60 (193)	Ø0.90 (Ø23)	Steel
	Indoor Duty Brake (Optional)	6.72 (171)	4.80 (122)	2.60 (66)	2.84 (72)			Yes		Ø0.90 (Ø23)	Steel
	Outdoor Duty (Optional)	7.21 (183)	4.84 (123)	2.52 (64)	3.43 (87)			Yes		G3/4 <sup>(2)</sup>	Steel
	Global EP.NA	6.71 (170)	4.92 (125)	2.50 (64)	3.43 (87)			Yes		NPT3/4 <sup>(2)</sup>	Al Diecast
	Global IE3 CE	6.75 (172)	4.92 (125)	2.50 (64)	2.47 (63)			Yes		2 - M25	Al Diecast
N-112M	Indoor Duty (Optional)	6.56 (167)	3.94 (100)	2.09 (53)	2.29 (58)	Yes	4.65 (118)	CF <sup>(1)</sup>	8.21 (209)	Ø0.90 (Ø23)	Steel
	Indoor Duty Brake (Optional)	7.35 (187)	4.80 (122)	2.60 (66)	2.84 (72)			Yes		Ø0.90 (Ø23)	Steel
	Outdoor Duty (Optional)	7.84 (199)	4.84 (123)	2.52 (64)	3.43 (87)			Yes		G3/4 <sup>(2)</sup>	Steel
	Global EP.NA	7.34 (186)	4.92 (125)	2.50 (64)	3.43 (87)			Yes		NPT3/4 <sup>(2)</sup>	Al Diecast
	Global IE3 CE	7.38 (188)	4.92 (125)	2.50 (64)	2.47 (63)			Yes		2 - M25	Al Diecast
	Global CE	7.38 (188)	4.92 (125)	2.50 (64)	2.47 (63)			Yes		2 - M25	Al Diecast
N-132S	Indoor Duty (Optional)	6.56 (167)	3.94 (100)	2.09 (53)	2.29 (58)	Yes	4.65 (118)	CF <sup>(1)</sup>	8.21 (209)	Ø0.90 (Ø23)	Steel
	Indoor Duty Brake (Optional)	7.35 (187)	4.80 (122)	2.60 (66)	2.84 (72)			Yes		Ø0.90 (Ø23)	Steel
	Outdoor Duty (Optional)	7.84 (199)	4.84 (123)	2.52 (64)	3.43 (87)			Yes		G1 <sup>(2)</sup>	Steel
	Global EP.NA	7.34 (186)	4.92 (125)	2.50 (64)	3.43 (87)			Yes		NPT1 <sup>(2)</sup>	Al Diecast
	Global IE3 CE	7.38 (188)	4.92 (125)	2.50 (64)	2.47 (63)			Yes		2 - M25	Al Diecast
N-132M	Indoor Duty (Optional)	7.98 (203)	4.80 (122)	2.60 (66)	2.84 (72)	Yes	5.43 (138)	Yes	9.57 (243)	Ø1.69 (Ø43)	Steel
	Outdoor Duty (Optional)	9.26 (235)	6.06 (154)	3.11 (79)	4.13 (105)					G1 <sup>(2)</sup>	Steel
	Global EP.NA	9.04 (230)	6.69 (170)	3.40 (86)	4.43 (113)					NPT1 <sup>(2)</sup>	Al Diecast
	Global IE3 CE	9.04 (230)	6.69 (170)	3.40 (86)	3.51 (89)					2-M32	Al Diecast

Note: <sup>(1)</sup> For "Available?" identified with "CF", please consult factory for brake configuration supporting this conduit box.  
<sup>(2)</sup> Default thread option shown. Alternate thread options available. Please consult factory for alternate conduit thread options.

**Table 4.31 Conduit Box Information (continued)**

Frame Size	Duty Rating	General Dimensions				Without Brake		With Brake		Conduit Opening	Material
		AB	C	D	E	Availability	L	Availability	L		
N-160M	Indoor Duty (Optional)	7.98 (203)	4.80 (122)	2.60 (66)	2.84 (72)	Yes	5.43 (138)	Yes	9.57 (243)	Ø1.69 (Ø43)	Steel
	Outdoor Duty (Optional)	9.26 (235)	6.06 (154)	3.11 (79)	4.13 (105)					G1-1/4 <sup>(2)</sup>	Steel
	Global EP.NA	9.04 (230)	6.69 (170)	3.40 (86)	4.43 (113)					NPT1-1/4 <sup>(2)</sup>	Al Diecast
	Global IE3 CE	9.04 (230)	6.69 (170)	3.40 (86)	3.51 (89)					2-M32	Al Diecast
N-160L	Indoor Duty (Optional)	9.20 (234)	4.80 (122)	2.60 (66)	2.84 (72)	Yes	7.01 (178)	No	12.30 (313)	Ø1.69 (Ø43)	Steel
	Indoor Duty Brake (Optional)	10.16 (258)	6.54 (166)	3.48 (88)	3.89 (99)			Yes		Ø1.69 (Ø43)	Steel
	Outdoor Duty (Optional)	10.48 (266)	6.06 (154)	3.11 (79)	4.13 (105)			Yes		G1-1/4 <sup>(2)</sup>	Steel
	Global EP.NA	10.26 (261)	6.69 (170)	3.40 (86)	4.43 (113)			Yes		NPT1-1/4 <sup>(2)</sup>	Al Diecast
	Global IE3 CE	10.26 (261)	6.69 (170)	3.40 (86)	3.51 (89)			Yes		2-M32	Al Diecast
N-180MS N-180M	Indoor Duty (Optional)	11.69 (297)	6.54 (166)	3.48 (88)	3.89 (99)	Yes	9.06 (230)	Yes	15.91 (404)	Ø1.93 (Ø49)	Steel
	Outdoor Duty (Optional)	14.08 (358)	7.56 (192)	4.53 (115)	6.89 (175)					G1-1/4 <sup>(2)</sup>	Cast Iron
	Global EP.NA	13.39 (340)	9.02 (229)	4.38 (111)	5.47 (139)					NPT1-1/4 <sup>(2)</sup>	Cast Iron
	Global IE3 CE	13.39 (340)	9.02 (229)	4.38 (111)	4.43 (113)					2 - M40	Cast Iron
N-180L N-200L	Indoor Duty (Optional)	11.69 (297)	6.54 (166)	3.48 (88)	3.89 (99)	Yes	9.06 (230)	Yes	15.91 (404)	Ø1.93 (Ø49)	Steel
	Outdoor Duty (Optional)	14.08 (358)	7.56 (192)	4.53 (115)	6.89 (175)					G2 <sup>(2)</sup>	Cast Iron
	Global EP.NA	13.39 (340)	9.02 (229)	4.38 (111)	5.47 (139)					NPT2 <sup>(2)</sup>	Cast Iron
	Global IE3 CE	13.39 (340)	9.02 (229)	4.38 (111)	4.43 (113)					2 - M40	Cast Iron
N-200LL N-225S	Indoor Duty (Optional)	16.24 (413)	9.45 (240)	4.19 (106)	6.30 (160)	Yes	16.81 (427)			Ø3.03 (Ø77)	Steel
	Outdoor Duty (Optional)	19.03 (483)	10.16 (258)	5.28 (134)	11.50 (292)					G2-1/2 <sup>(2)</sup>	Cast Iron
	Global EP.NA	16.54 (420)	10.63 (270)	5.14 (131)	6.22 (158)					NPT3 <sup>(2)</sup>	Cast Iron
	Global IE3 CE	16.54 (420)	10.63 (270)	5.14 (131)	5.13 (130)					2 - M63	Cast Iron

**Note:** (1) For "Available?" identified with "CF", please consult factory for brake configuration supporting this conduit box.  
 (2) Default thread option shown. Alternate thread options available. Please consult factory for alternate conduit thread options.

**Fractional Motor Performance Data - 60Hz Operation**

**Table 4.32a Standard Three Phase, 230/460V, 60Hz, 1800 RPM Synchronous Speed, TEFC - UL Recognized**

Motor Capacity		Frame Size	Full Load (A)			Current			Starting Torque % of FL	Breakdown Torque % of FL	Nominal Efficiency %	Power Factor %	NEMA Code Letter	
HP	kW		Rated RPM	Torque		Full Load		No Load % of FL						Starting % of FL
				in-lbs	N-m	230V	460V							
1/8**	0.1	V-63S	1730	4.55	0.514	0.66	0.33	86.1	424	326	308	63.3	60.0	K
1/4	0.2	V-63M	1730	9.10	1.03	1.12	0.56	79.6	464	300	287	69.2	65.1	K
1/3	0.25	V-63M	1700	12.2	1.38	1.24	0.62	72.0	419	237	226	70.1	72.0	G
1/2	0.4	V-71M	1750	18.0	2.03	2.15	1.08	77.7	456	295	276	71.5	65.4	J
3/4	0.55	V-80S	1720	27.5	3.11	2.47	1.24	68.4	500	266	261	76.5	73.1	H

\*\* 1/8 HP is TENV

**Table 4.32b Standard Three Phase, 240/480V, 60Hz, 1800 RPM Synchronous Speed, TEFC - UL Recognized**

Motor Capacity		Frame Size	Full Load (A)			Current			Starting Torque % of FL	Breakdown Torque % of FL	Nominal Efficiency %	Power Factor %	NEMA Code Letter	
HP	kW		Rated RPM	Torque		Full Load		No Load % of FL						Starting % of FL
				in-lbs	N-m	240V	480V							
1/8**	0.1	V-63S	1740	4.53	0.512	0.69	0.35	87.4	429	364	341	61.9	56.3	L
1/4	0.2	V-63M	1740	9.05	1.02	1.16	0.58	83.6	466	335	317	68.2	61	K
1/3	0.25	V-63M	1710	12.3	1.39	1.27	0.63	77.0	429	268	238	69.8	68.1	H
1/2	0.4	V-71M	1750	18.0	2.04	2.27	1.13	83.2	460	328	303	70.4	60.4	K
3/4	0.55	V-80S	1730	27.3	3.09	2.52	1.26	73.4	508	294	285	76.0	69.2	H

\*\* 1/8 HP is TENV

**Table 4.32c Non-Standard Three Phase, 230/460V, 60Hz, 1800 RPM Synchronous Speed, TEFC - CSA Approved**

Motor Capacity		Frame Size	Full Load (A)			Current			Starting Torque % of FL	Breakdown Torque % of FL	Nominal Efficiency %	Power Factor %	NEMA Code Letter	
HP	kW		Rated RPM	Torque		Full Load		No Load % of FL						Starting % of FL
				in-lbs	N-m	230V	460V							
1/8**	0.1	V-63S	1730	4.55	0.514	0.66	0.33	86.1	424	326	308	63.3	60.0	K
1/4	0.2	V-63M	1730	9.10	1.03	1.12	0.56	79.6	464	300	287	69.2	65.1	K
1/3	0.25	V-63M	1700	12.2	1.38	1.24	0.62	72.0	419	237	226	70.1	72.0	G
1/2	0.4	V-71M	1750	18.0	2.03	2.15	1.08	77.7	456	295	276	71.5	65.4	J
3/4	0.55	V-80S	1720	27.5	3.11	2.47	1.24	68.4	500	266	261	76.5	73.1	H

\*\* 1/8 HP is TENV

**Table 4.32d Non-Standard Three Phase, 575V, 60Hz, 1800 RPM Synchronous Speed, TEFC - CSA Approved**

Motor Capacity		Frame Size	Full Load (A)			Current			Starting Torque % of FL	Breakdown Torque % of FL	Nominal Efficiency %	Power Factor %	NEMA Code Letter	
HP	kW		Rated RPM	Torque		Full Load		No Load % of FL						Starting % of FL
				in-lbs	N-m	575V								
1/8**	0.1	V-63S	1720	4.58	0.518	0.28		91.8	464	376	391	65.5	54.1	M
1/4	0.2	V-63M	1730	9.10	1.03	0.48		85.4	458	316	340	69.4	60.1	K
1/3	0.25	V-63M	1710	12.2	1.38	0.52		78.8	423	250	270	71.3	67.5	H
1/2	0.4	V-71M	1700	18.5	2.09	0.79		75.8	468	309	300	75.2	63.1	J
3/4	0.55	V-80S	1700	27.8	3.14	1.00		74.0	530	260	268	75.4	71.4	H

\*\* 1/8 HP is TENV



**Fractional AF-Motor (AV) Performance Data - 60Hz Operation**

**Table 4.33a Three Phase, 230/460V, 60Hz, 1800 RPM Synchronous Speed, 10:1 Constant Torque Speed Range TEFC**

Motor Capacity		Frame Size	Wiring	Full Load Torque		Voltage V	60 Hz Current Amp	Speed RPM	Voltage V	6 Hz Current Amp	Speed RPM	No Load Current @ 60 Hz
HP	kW			in-lbs	N-m							
1/8	0.1	VA-63S	High Voltage	4.77	0.54	460	0.49	1770	68	0.37	125	0.46
			Low Voltage			230	0.98		34	0.74		0.92
1/4	0.2	VA-63M	High Voltage	9.6	1.08	460	0.91	1765	68	0.79	125	0.87
			Low Voltage			230	1.8		34	1.6		1.74
1/3	0.25	VA-63M	High Voltage	12	1.36	460	0.94	1755	78	0.87	125	0.87
			Low Voltage			230	1.9		34	1.7		1.74
1/2	0.4	VA-71M	High Voltage	19.2	2.17	460	1.3	1750	70	1.1	115	1.21
			Low Voltage			230	2.6		35	2.3		2.42
3/4	0.55	VA-80S	High Voltage	26.3	2.97	460	1.7	1760	62	1.6	125	1.54
			Low Voltage			230	3.3		31	3.1		3.07

**Table 4.33b Three Phase, 230/460V, 60Hz, 1800 RPM Synchronous Speed, 10:1 Constant Torque Speed Range TEFC - CSA Approved**

Motor Capacity		Frame Size	Wiring	Full Load Torque		Voltage V	60 Hz Current Amp	Speed RPM	Voltage V	6 Hz Current Amp	Speed RPM	No Load Current @ 60 Hz
HP	kW			in-lbs	N-m							
1/8	0.1	VA-63S	High Voltage	4.77	0.54	460	0.49	1770	68	0.37	125	0.46
			Low Voltage			230	0.98		34	0.74		0.92
1/4	0.2	VA-63M	High Voltage	9.57	1.08	460	0.91	1765	68	0.79	125	0.87
			Low Voltage			230	1.8		34	1.6		1.74
1/3	0.25	VA-63M	High Voltage	12.0	1.36	460	0.94	1755	78	0.87	125	0.87
			Low Voltage			230	1.9		34	1.7		1.74
1/2	0.4	VA-71M	High Voltage	19.3	2.17	460	1.3	1750	70	1.1	115	1.21
			Low Voltage			230	2.6		35	2.3		2.42
3/4	0.55	VA-80S	High Voltage	26.3	2.97	460	1.7	1765	62	1.5	145	1.54
			Low Voltage			230	3.3		31	2.9		3.08

**Table 4.33c Three Phase, 575V, 60Hz, 1800 RPM Synchronous Speed, 10:1 Constant Torque Speed Range TEFC - CSA Approved**

Motor Capacity		Frame Size	Full Load Torque		Voltage V	60 Hz Current Amp	Speed RPM	Voltage V	6 Hz Current Amp	Speed RPM	No Load Current @ 60 Hz
HP	kW		in-lbs	N-m							
1/8	0.1	VA-63S	4.77	0.54	575	0.4	1770	85	0.3	130	0.4
1/4	0.2	VA-63M	9.57	1.08	575	0.7	1765	77	0.5	85	0.62
1/3	0.25	VA-63M	12.0	1.36	575	0.7	1755	95	0.7	120	0.62
1/2	0.4	VA-71M	19.4	2.17	575	0.94	1745	88	0.86	110	0.86
3/4	0.55	VA-80S	26.3	2.97	575	1.3	1765	76	1.1	140	0.98

**Motor Performance Data - EP.NA Motor, 60Hz Operation**

**Table 4.34 Three Phase, 230/460v, 60Hz, 1800 RPM Synchronous Speed, TEFC**

Motor Capacity		Frame Size	Full Load (A)			Current				Starting Torque % of FL	Breakdown Torque % of FL	Nominal Efficiency %	Power Factor %	NEMA Code Letter
HP	kW		Rated RPM	Torque		Full Load		No Load % of FL	Starting % of FL					
				in-lbs	N-m	230V	460V							
1	0.75	N-80M	1730	36.6	4.14	3.06	1.53	62.0	692	343	403	85.5	72.0	K
1.5	1.1	N-90S	1730	53.7	6.07	4.15	2.08	52.1	659	277	341	86.5	76.5	J
2	1.5	N-90L	1730	73.2	8.28	5.61	2.80	52.7	694	284	356	86.5	77.2	J
3	2.2	N-100L	1740	107	12.1	7.66	3.83	47.5	824	317	389	89.5	80.7	K
5	3.7	N-112M	1750	179	20.2	12.3	6.17	44.5	821	244	379	89.5	83.9	K
7.5	5.5	N-132S	1760	264	29.8	17.8	8.90	42.9	1000	290	461	91.7	84.2	L
10	7.5	N-132M	1760	360	40.7	24.4	12.2	36.1	606	193	277	91.7	84.1	G
15	11	N-160M	1770	525	59.3	38.4	19.2	48.0	736	274	369	92.4	77.8	J
20	15	N-160L	1770	716	80.9	47.7	23.8	36.5	828	227	351	93.0	85.0	J
25	18.5	N-180MS	1780	878	99.2	56.9	28.5	31.7	805	245	308	93.6	86.4	J
30	22	N-180M	1780	1040	118	67.4	33.7	28.8	673	206	258	93.6	87.1	G
40	30	N-180L	1780	1420	161	91.6	45.8	29.5	792	242	295	94.1	87.0	J
50	37	N-200L	1780	1760	198	113	56.5	31.7	890	276	328	94.5	86.7	K
60	45	N-200LL	1780	2140	241	138	69.0	37.7	962	308	393	95.0	86.3	K

**Table 4.35 Three Phase, 240/480V, 60Hz, 1800 RPM Synchronous Speed, TEFC**

Motor Capacity		Frame Size	Full Load (A)			Current				Starting Torque % of FL	Breakdown Torque % of FL	Nominal Efficiency %	Power Factor %	NEMA Code Letter
HP	kW		Rated RPM	Torque		Full Load		No Load % of FL	Starting % of FL					
				in-lbs	N-m	240V	480V							
1	0.75	N-80M	1740	36.4	4.12	3.05	1.52	66.2	723	380	439	85.5	69.2	L
1.5	1.1	N-90S	1740	53.4	6.04	4.09	2.05	56.6	704	310	375	86.5	74.1	J
2	1.5	N-90L	1730	73.2	8.28	5.54	2.77	57.8	722	316	387	86.5	74.5	K
3	2.2	N-100L	1750	106	12.0	7.53	3.77	52.1	911	352	446	89.5	78.4	L
5	3.7	N-112M	1760	178	20.1	12.1	6.06	49.3	886	268	421	89.5	81.7	K
7.5	5.5	N-132S	1760	264	29.8	17.5	8.76	47.6	1060	321	506	91.7	82.0	M
10	7.5	N-132M	1760	360	40.7	23.8	11.9	40.3	652	212	308	91.7	82.2	H
15	11	N-160M	1770	525	59.3	38.7	19.3	54.0	760	305	405	92.4	74.0	K
20	15	N-160L	1770	716	80.9	46.5	23.2	41.0	893	251	387	93.0	83.3	K
25	18.5	N-180MS	1780	878	99.2	55.1	27.6	35.2	881	268	340	93.6	85.3	K
30	22	N-180M	1780	1040	118	64.9	32.4	29.9	748	224	285	93.6	86.5	H
40	30	N-180L	1780	1420	161	88.8	44.4	33.3	867	266	326	94.1	85.9	J
50	37	N-200L	1780	1760	198	110.0	55.1	35.7	968	304	361	94.5	85.2	K
60	45	N-200LL	1780	2140	241	135.0	67.6	42.0	1050	329	430	95.0	84.4	L

Technical Information

Technical Information



**Motor Performance Data - EP.NA Motor, 60Hz Operation (continued)**

**Table 4.36 Three Phase, 575V, 60Hz, 1800 RPM Synchronous Speed, TEFC**

Motor Capacity		Frame Size	Full Load (A)			Current			Starting Torque % of FL	Breakdown Torque % of FL	Nominal Efficiency %	Power Factor %	NEMA Code Letter
HP	kW		Rated RPM	Torque		Full Load 575V	No Load % of FL	Starting % of FL					
				in-lbs	N-m								
1	0.75	N-80M	1740	36.4	4.12	1.36	72.7	768	430	500	85.5	64.4	M
1.5	1.1	N-90S	1740	53.4	6.04	1.69	57.8	743	313	386	86.5	74.5	K
2	1.5	N-90L	1730	73.2	8.28	2.22	52.3	685	272	341	86.5	77.9	J
3	2.2	N-100L	1740	107	12.1	3.05	47.2	839	322	404	89.5	80.8	K
5	3.7	N-112M	1750	179	20.2	4.86	42.0	798	230	355	89.5	84.9	J
7.5	5.5	N-132S	1760	264	29.8	7.12	42.5	957	263	429	91.7	84.7	L
10	7.5	N-132M	1760	360	40.7	10.1	43.9	704	230	332	91.7	81.3	H
15	11	N-160M	1760	528	59.7	14.5	41.7	710	237	331	92.4	82.3	H
20	15	N-160L	1770	716	80.9	19.4	41.1	915	257	396	93.0	83.3	K
25	18.5	N-180MS	1780	878	99.2	22.8	35.2	916	276	350	93.6	86.1	K
30	22	N-180M	1780	1040	118	26.8	29.9	779	230	293	93.6	87.2	H
40	30	N-180L	1780	1420	161	37.0	31.5	857	263	321	94.1	86.1	J
50	37	N-200L	1780	1760	198	45.5	36.0	954	297	352	94.5	85.9	K
60	45	N-200LL	1780	2140	241	55.7	40.5	1040	324	422	95.0	85.4	L

**Motor Performance Data - CE Motor, 50Hz Operation**

**Table 4.37a Three Phase, 220/380V, 50Hz, 1500 RPM Synchronous Speed, TEFC**

Motor Capacity		Frame Size	Full Load (A)			Current			Starting Torque % of FL	Breakdown Torque % of FL	Nominal Efficiency %	Power Factor %	NEMA Code Letter	
HP	kW		Rated RPM	Torque		Full Load		No Load % of FL						Starting % of FL
				in-lbs	N-m	220V	380V							
1/8**	0.1	V-63S	1400	6.03	0.682	0.6	0.35	78.3	371	230	226	63.3	69.1	H
1/4	0.2	V-63M	1390	12.2	1.37	1.05	0.61	71.5	361	206	206	67.6	73.7	F
1/3	0.25	V-63M	1360	15.5	1.75	1.22	0.71	61.4	338	195	181	69.1	77.8	E
1/2	0.4	V-71M	1410	24.0	2.71	2.06	1.19	68.3	353	201	204	69.7	73.5	F
3/4	0.55	V-80S	1400	33.2	3.75	2.45	1.42	58.5	373	206	196	73.4	80.2	E
1	0.75	N-80M	1430	44.3	5.01	3.46	2.00	66.2	579	383	402	84.7	67.9	K
1.5	1.1	N-90S	1430	65.0	7.35	4.49	2.59	54.4	606	296	343	85.4	75.1	J
2	1.5	N-90L	1420	89.2	10.1	6.10	3.52	54.9	578	304	338	85.4	75.5	H
3	2.2	N-100L	1440	129	14.6	8.58	4.96	52.2	758	344	418	88.6	78.0	K
4	3.0	N-112S	1430	177	20.0	11.3	6.50	45.6	676	316	365	87.7	80.8	J
5	3.7	N-112M	1460	214	24.2	13.5	7.80	48.5	743	266	378	89.6	81.2	J
5.5	4.0	N-112M	1450	233	26.3	14.4	8.30	45.2	692	266	378	88.9	82.9	J
7.5	5.5	N-132S	1460	318	36.0	-	11.5	49.6	907	316	471	90.6	80.7	L
10	7.5	N-132M	1460	434	49.1	-	15.8	44.9	590	213	315	90.8	79.6	H
15	11	N-160M	1460	636	71.9	-	22.3	38.5	551	200	283	91.4	81.6	G
20	15	N-160L	1470	862	97.4	-	30.5	43.1	619	230	304	92.6	80.6	H
25	18.5	N-180MS	1480	1060	119	-	35.6	36.9	735	245	338	94.0	83.5	J
30	22	N-180M	1480	1260	142	-	41.9	31.4	624	206	284	93.5	85.4	G

\*\* 1/8 HP is TENV

**Table 4.37b Three Phase, 230/400V, 50Hz, 1500 RPM Synchronous Speed, TEFC**

Motor Capacity		Frame Size	Full Load (A)			Current			Starting Torque % of FL	Breakdown Torque % of FL	Nominal Efficiency %	Power Factor %	NEMA Code Letter	
HP	kW		Rated RPM	Torque		Full Load		No Load % of FL						Starting % of FL
				in-lbs	N-m	230V	400V							
1/8**	0.1	V-63S	1420	5.95	0.672	0.62	0.36	83.6	361	261	255	62.1	64.9	H
1/4	0.2	V-63M	1410	12.0	1.35	1.08	0.62	77.3	371	236	233	67.1	69.5	G
1/3	0.25	V-63M	1380	15.3	1.73	1.22	0.7	68.4	371	225	205	69.4	74.2	F
1/2	0.4	V-71M	1420	23.8	2.69	2.13	1.23	75.6	366	229	229	68.5	68.7	G
3/4	0.55	V-80S	1410	32.9	3.72	2.45	1.41	65.2	390	225	219	73.6	76.7	F
1	0.75	N-80M	1440	44.0	4.97	3.54	2.05	72.3	613	423	446	84.6	62.7	L
1.5	1.1	N-90S	1440	64.5	7.29	4.50	2.60	61.4	640	336	387	85.6	71.1	K
2	1.5	N-90L	1430	88.6	10.0	6.17	3.56	62.2	601	338	375	85.8	72.3	J
3	2.2	N-100L	1450	128	14.5	8.56	4.95	60.2	798	382	465	88.7	74.1	L
4	3.0	N-112S	1440	176	19.9	11.2	6.45	53.2	727	352	419	87.9	76.9	K
5	3.7	N-112M	1460	214	24.2	13.7	7.90	56.0	766	294	420	89.0	77.5	K
5.5	4.0	N-112M	1460	231	26.2	14.4	8.30	53.4	733	273	388	89.1	78.8	K
7.5	5.5	N-132S	1460	318	36.0	-	11.6	56.6	937	351	524	90.6	76.2	M
10	7.5	N-132M	1460	434	49.1	-	16.0	51.9	704	206	350	91.2	75.5	K

\*\* 1/8 HP is TENV

Table continued on next page.

Cyclo® BBB4

Technical Information

Cyclo® BBB4

Technical Information

Motor Performance Data - IE3 CE Motor, 50Hz Operation (continued)

Table 4.37b continued... Three Phase, 230/400V, 50Hz, 1500 RPM Synchronous Speed, TEFC

Motor Capacity		Frame Size	Full Load (A)			Current				Starting Torque % of FL	Breakdown Torque % of FL	Nominal Efficiency %	Power Factor %	NEMA Code Letter
HP	kW		Rated RPM	Torque		Full Load		No Load % of FL	Starting % of FL					
				in-lbs	N-m	230V	400V							
15	11	N-160M	1470	632	71.5	-	22.2	54.4	635	257	378	91.5	73.0	J
20	15	N-160L	1480	856	96.8	-	30.6	50.6	647	256	338	92.5	76.3	J
25	18.5	N-180MS	1480	1060	119	-	35.4	43.8	777	272	375	93.9	80.1	K
30	22	N-180M	1480	1260	142	-	40.9	37.9	673	227	314	93.8	82.7	H
40	30	N-180L	1480	1710	194	-	59.1	47.3	730	265	382	94.0	78.2	J
50	37	N-200L	1480	2110	239	-	69.5	40.8	753	266	361	94.1	81.4	J
60	45	N-200LL	1480	2570	290	-	82.5	41.7	845	317	411	94.6	83.5	K

Table 4.38 Three Phase, 240/415V, 50Hz, 1500 RPM Synchronous Speed, TEFC

Motor Capacity		Frame Size	Full Load (A)			Current				Starting Torque % of FL	Breakdown Torque % of FL	Nominal Efficiency %	Power Factor %	NEMA Code Letter
HP	kW		Rated RPM	Torque		Full Load		No Load % of FL	Starting % of FL					
				in-lbs	N-m	240V	415V							
1/8**	0.1	V-63S	1420	5.95	0.672	0.65	0.37	88.1	378	286	277	60.9	60.9	J
1/4	0.2	V-63M	1410	12.0	1.35	1.1	0.64	80.9	375	260	253	66.4	65.7	H
1/3	0.25	V-63M	1390	15.2	1.72	1.23	0.71	73.0	380	247	223	69.5	70.6	G
1/2	0.4	V-71M	1430	23.6	2.67	2.23	1.29	80.6	364	250	247	67.0	64.4	H
3/4	0.55	V-80S	1420	32.7	3.7	2.46	1.43	70.6	413	248	237	73.6	73.1	G
1	0.75	N-80M	1450	43.7	4.94	3.65	2.11	76.3	600	461	484	84.1	59.4	L
1.5	1.1	N-90S	1440	64.5	7.29	4.57	2.64	66.3	654	368	422	85.5	67.4	K
2	1.5	N-90L	1440	88.0	9.95	6.29	3.63	68.7	611	366	406	85.4	67.3	K
3	2.2	N-100L	1450	128	14.5	8.83	5.10	66.1	805	412	502	88.3	69.3	M
4	3.0	N-112S	1440	176	19.9	11.3	6.55	59.8	751	387	458	87.9	73.2	L
5	3.7	N-112M	1460	214	24.2	13.9	8.00	62.5	788	319	453	89.2	72.7	L
5.5	4.0	N-112M	1460	231	26.2	14.5	8.35	59.7	752	294	418	89.0	74.8	K
7.5	5.5	N-132S	1470	316	35.7	-	11.9	64.1	958	378	564	90.2	72.0	N
10	7.5	N-132M	1470	431	48.7	-	16.2	58.5	629	254	378	90.6	71.1	J
15	11	N-160M	1470	632	71.5	-	22.4	50.6	617	249	354	91.6	74.6	H
20	15	N-160L	1480	856	96.8	-	31.2	57.0	659	275	364	92.2	72.3	J
25	18.5	N-180MS	1490	1050	119	-	35.7	49.9	800	292	404	93.8	76.7	K
30	22	N-180M	1480	1260	142	-	40.8	43.6	699	245	339	93.6	80.2	J
40	30	N-180L	1480	1710	194	-	60.2	52.9	743	285	411	93.6	74.2	K
50	37	N-200L	1480	2110	239	-	70.0	46.0	777	287	391	94.1	78.2	K
60	45	N-200LL	1480	2570	290	-	82.5	47.0	876	341	442	94.5	80.7	L

\*\* 1/8 HP is TENV

Motor Thermal Rating for Cyclic Applications

Table 4.39 Motor Thermal Rating Table

Motor Power HP (kW)	Allowable C x Z				Motor Inertia lb-in <sup>2</sup> (kg-m <sup>2</sup> )	
	below 35% ED <sup>[1]</sup>	35% ~ 50% ED <sup>[1]</sup>	50% ~ 80% ED <sup>[1]</sup>	80% ~ 100% ED <sup>[1]</sup>	Standard	with Brake
1/8 (0.1)	3200	3000	2000	1200	1.11 (0.000325)	1.2 (0.00035)
1/4 (0.2)	2200	2800	2800	2500	1.71 (0.0005)	1.88 (0.00055)
1/3 (0.25)	2200	2800	2800	2500	1.71 (0.0005)	1.88 (0.00055)
1/2 (0.4)	1800	2200	1500	1500	2.22 (0.00065)	2.31 (0.000675)
3/4 (0.55)	1800	2200	1500	1500	3.45 (0.00101)	3.79 (0.00111)
1 (0.75)	1400	1400	800	500	8.03 (0.00235)	8.82 (0.00258)
1.5 (1.1)	1400	1400	800	500	11.5 (0.00337)	13.5 (0.00396)
2 (1.5)	1200	1200	500	400	13.4 (0.00391)	15.4 (0.0045)
3 (2.2)	1000	900	400	200	30.1 (0.0088)	33.4 (0.00978)
5 (3.7)	800	800	800	700	66.3 (0.0194)	71.4 (0.0209)
7.5 (5.5)	300	300	200	150	99.4 (0.0291)	105 (0.0306)
10 (7.5)	400	350	300	300	140 (0.0409)	154 (0.045)
15 (11)	200	200	150	150	192 (0.0561)	206 (0.0602)
20 (15)	100	90	78	68	340 (0.0995)	393 (0.115)
25 (18.5)	75	65	55	50	875 (0.256)	926 (0.271)
30 (22)	75	65	55	50	875 (0.256)	926 (0.271)
40 (30)	55	40	17	10	1110 (0.326)	1170 (0.342)

Note: [1] % ED = Duty Cycle.

The calculated C x Z value (steps 1 – 3 outlined below) should be less than the allowable value listed in Motor Thermal Rating table above.

1. Obtain the C value:

$$C = \frac{I_M + I_L}{I_M}$$

$I_M$  = Moment of Inertia of the Motor.  
 $I_L$  = Moment of Inertia of the Load as seen from the motor shaft.

(c) Calculate Z by adding  $Z_r$  to  $Z_i$  by the following formula.

$$Z = Z_r + \frac{1}{2} \cdot Z_i = \frac{3600}{t_a + t_b} \cdot \left( nr + \frac{1}{2} ni \right) \text{ (times/hour)}$$

3. Calculate C x Z (the product of C and Z)

Use the value of C obtained in Step (1) and value of Z obtained in Step (2).

4. Obtain the duty cycle %ED and compare calculated C x Z in the appropriate column from Motor Thermal Rating Table.

$$\%ED = \frac{t_a}{t_a + t_b} \cdot 100$$

$t_a$  = on-time  
 $t_b$  = off-time

2. Obtain the Z value (number of starts per hour):

(a) Assume that one operating period consists of "on-time"  $t_a$  (sec.), "off-time"  $t_b$  (sec.) and the motor is started  $nr$  (times/cycle).

$$Z_r = \frac{3600 \cdot nr}{t_a + t_b} \text{ (times/hour)}$$

(b) When inching,  $ni$  (times/cycle) is included in 1 cycling ( $t_a+t_b$ ), the number of inching times per hour  $Z_i$ , is then included in the number of starts.

$$Z_i = \frac{3600 \cdot ni}{t_a + t_b} \text{ (times/hour)}$$

### Standard Wiring Diagrams

Illustrated below are the wiring diagrams for our standard motors. For additional information please refer to the motor name plate. Due to changes in design features, this diagram may not always agree with that on the motor. If different, the motor diagram found inside the conduit box cover should be used.

**Table 4.40 Wiring Configuration for 230/460V, 60Hz and 575V, 60Hz by EP.NA Motor**

Motor HP x P	230/460V, 60Hz			575V, 60Hz		
	Internal	No. of Leads	Diagram	Internal	No. of Leads	Diagram
1/8 x 4	WYE	9	9-Lead WYE	WYE	3	3-Lead
1/4 x 4						
1/3 x 4						
1/2 x 4						
3/4 x 4						
1 x 4						
1.5 x 4						
2 x 4	DELTA	9	9-Lead DELTA	DELTA	3	3-Lead
3 x 4						
5 x 4						
7.5 x 4						
10 x 4						
15 x 4						
20 x 4						
25 x 4						
30 x 4						
40 x 4						
50 x 4						
60 x 4						

**Figure 4.6a 9-Lead WYE**

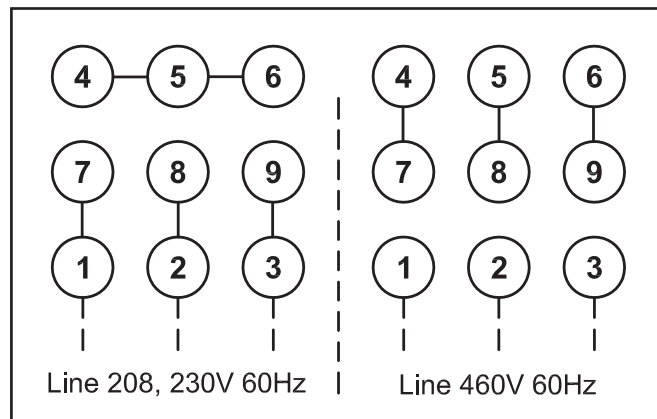

**Figure 4.6b 9-Lead DELTA**

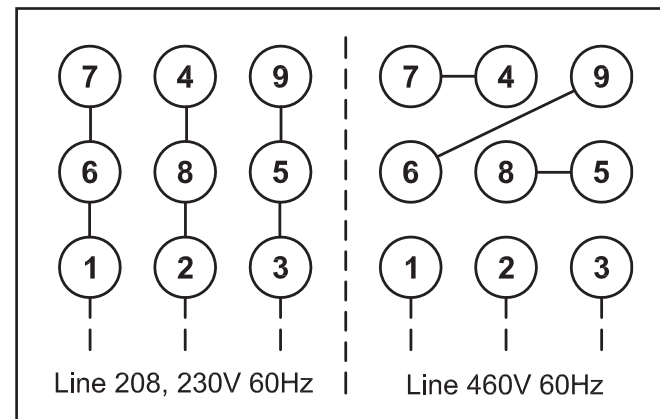

**Figure 4.6c 3-Lead SINGLE**

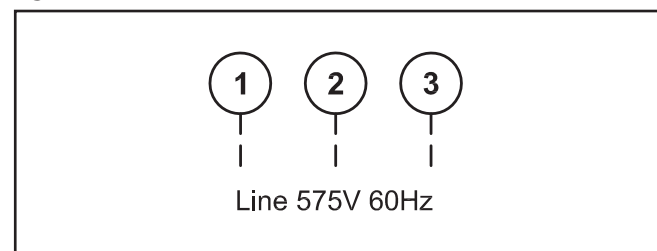

### Three-Phase IE3 CE Motors

**Table 4.41 Wiring Configuration by IE3 CE Motor**

Motor kW x P	Voltage Configuration	Wiring Diagram
.75 x 4	220/380V, 50Hz Three Phase	DELTA-WYE
1.1 x 4		
1.5 x 4		
2.2 x 4		
3.0 x 4		
3.7 x 4		
5.5 x 4	380V, 50Hz Three Phase	WYE-Start DELTA-Run
7.5 x 4		
11 x 4		
15 x 4		
18.5 x 4		
22 x 4		
30 x 4		
37 x 4		
45 x 4		
55 x 4		

**Figure 4.7 DELTA-WYE Diagram**

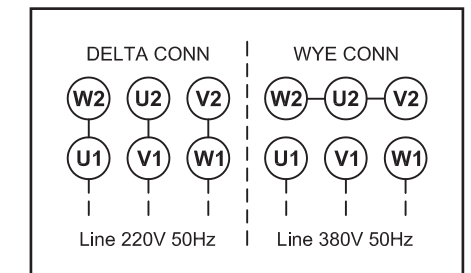

**Figure 4.8 WYE-Start DELTA-Run Diagram**

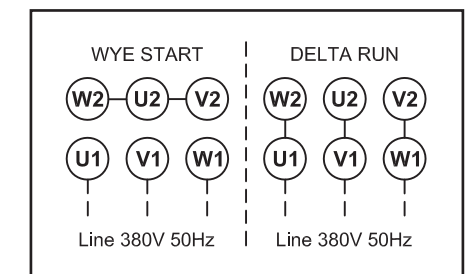

### Brakemotor Characteristics

The brakemotor on Cyclo® gearmotors operates with direct current supplied by a dual voltage rectifier for 230/460V, or single voltage rectifier/power module for other noted voltages. Rectifier or power module is mounted in the motor conduit box.

When used for outdoor installations, standard brakemotor must be protected by a cover. Such covers are available from the factory, please inquire when ordering.

**Note:** Advise the factory when ordering if you require brake torque greater or lesser than those shown as standard in the Brakemotor Characteristics table below.

### Brake Characteristics

Table 4.42 Brake Characteristics - Standard torque, Delay Time, Work Capacity

Brake Model	Motor Capacity		Standard Braking Torque ft - lbs (N - m)	Braking Delay Time (sec)			Brake Work Capacity		
	HP x 4P	kW x 4P		Normal Braking Action		Fast Braking Action	Allowable E <sub>0</sub> (J/min)	Gap Adjust (x 10 <sup>7</sup> J)	Total E <sub>1</sub> (x 10 <sup>7</sup> J)
				Standard Wiring	Inverter Wiring <sup>[2]</sup>				
FB-01A	1/8	0.1	0.7 (1.0)	0.15 ~ 0.2	0.08 ~ 0.12	0.015 ~ 0.02	1080	2.6	6.7
FB-02A	1/8 ~ 1/3	0.1 ~ 0.25	1.4 (2.0)						
FB-05A	1/4 ~ 1/2	0.2 ~ 0.4	2.9 (4.0)						
FB-1D	1/2	0.4	5.8 (7.5)	0.2 ~ 0.3	0.1 ~ 0.15	0.01 ~ 0.015	1620	7.0	33.1
FB-2D	3/4	0.55	11 (15)						
FB-3D	3/4	0.55	16 (22)						
FB-1E	1	0.75	5.5 (7.5)	0.25 ~ 0.45	0.15 ~ 0.25	0.01 ~ 0.02	2580	11.6	38.7
FB-1HE	1.5	1.1	8.0 (11)						
FB-2E	2	1.5	11 (15)						
FB-3E	3	2.2	16 (22)	0.75 ~ 0.95	0.4 ~ 0.5	0.02 ~ 0.04	5720	26.3	105.3
FB-5E	5	3.7	30 (40)						
FB-8E	7.5	5.5	40 (55)						
FB-10E	10	7.5	59 (80)	1.8 ~ 2.0	0.6 ~ 0.7	0.02 ~ 0.04	10800	110.2	551.1
FB-15E	15	11	80 (110)						
FB-20	20	15	110 (150)						
FB-30	25	18.5	140 (190)	-	-	0.06 ~ 0.14 <sup>[3]</sup>	22440	191.6	1150
	30	22	160 (220)						
	40	30	150 (200)						
ESB-250 <sup>[2]</sup>	50	37	200 (266)	-	-	0.065	30672	52	267
	60	45	235 (320)						

**Notes:** [1] Also applies to wiring where brake is powered separately from the motor leads.

[2] Available only with power module rated for use at 200VAC or 220VAC.

Above table applies to standard brake specification under standard brake torque. Special brakes may perform differently from those shown.

Initial brake torque may be lower than specified brake torque.

If this is the case, under light load start and stop the motor to wear-in the braking surface.

To improve performance for positioning accuracy or lifting applications, consider using fast braking action circuit.

If the brake is operated at a rate greater than the Allowable Brake Work Capacity, E<sub>0</sub>,

the brake performance may degrade or become inoperable.

ESB Type brake uses a power module (HD-110M3) that is installed separately from the brakemotor.

ESB Type brake cannot be operated in a vertical orientation.

[3] Values shown for 200V Class and 400V Class Brakes. Please consult factory for 575V Brakes.

### Brakemotor Characteristics

Table 4.43 Brake Maintenance - Brake Gap, Brake Lining Thickness

Brake Model	Brake Gap			Brake Lining Thickness			
	Spec. (Initial) inch (mm)	Limit inch (mm)	Adjustment Method	Spec. (Initial) inch (mm)	Limit inch (mm)		
FB-01A	0.008 ~ 0.014 (0.2 ~ 0.35)	0.020 (0.5)	Twist detent	0.276 (7.0)	0.256 (6.5)		
FB-02A							
FB-05A							
FB-1D	0.012 ~ 0.016 (0.3 ~ 0.4)	0.024 (0.60)	Shim	0.347 (8.8)	0.307 (7.8)		
FB-2D							
FB-3D							
FB-1E	0.028 (0.70)						
FB-1HE	0.024 (0.60)						
FB-1E	0.010 ~ 0.014 (0.25 ~ 0.35)	0.030 (0.75)	Nut	0.347 (8.8)	0.307 (7.8)		
FB-2E							
FB-3E							
FB-5E	0.014 ~ 0.018 (0.35 ~ 0.45)	0.040 (1.0)				0.394 (10.0)	0.236 (6.0)
FB-8E							
FB-10E							
FB-15E	0.014 ~ 0.018 (0.35 ~ 0.45)	0.047 (1.2)	Nut	0.433 (11.0)	0.276 (7.0)		
FB-20							
FB-30							
FB-20	0.024 ~ 0.028 (0.6 ~ 0.7)	0.059 (1.5)				0.630 (16.0)	0.472 (12.0)
FB-30							
ESB-250 <sup>[2]</sup>	0.028 (0.7)	0.079 (2.0)	Threaded Ring	0.236 (6.0)	0.142 (3.6)		

**Notes:** Available only with power module rated for use at 200VAC or 220VAC.

ESB Type brake uses a power module (HD-110M3) that is installed separately from the brakemotor.

ESB Type brake cannot be operated in a vertical orientation.



**Brakemotor: Brake Current Rating**

Table 4.44a Brake Current for Standard Fractional Motor and AF-Motor (AV)

Brake Model	230VAC, 50/60Hz			460VAC, 50/60Hz			575VAC, 50/60Hz		
	Vdc (V)	Idc (A)	Iac (A)	Vdc (V)	Idc (A)	Iac (A)	Vdc (V)	Idc (A)	Iac (A)
FB-01A	207VDC Full Wave	0.05	0.06	207VDC Half Wave	0.05	0.04	259VDC Half Wave	0.05	0.03
FB-02A		0.08	0.1		0.08	0.06		0.09	0.07
FB-05A		0.1	0.1		0.1	0.1		0.1	0.1
FB-1D		0.1	0.1		0.1	0.1		0.1	0.1
FB-2D		0.2	0.2		0.2	0.2		0.2	0.2
FB-3D		0.2	0.2		0.2	0.2		0.2	0.2

Table 4.44b Brake Current for EP.NA Motor

Brake Model	230VAC, 50/60Hz			240VAC, 50/60Hz			460VAC, 50/60Hz			480VAC, 50/60Hz		
	Vdc (V)	Idc (A)	Iac (A)	Vdc (V)	Idc (A)	Iac (A)	Vdc (V)	Idc (A)	Iac (A)	Vdc (V)	Idc (A)	Iac (A)
FB-1E	207VDC Full Wave	0.1	0.1	216VDC Full Wave	0.1	0.1	207VDC Half Wave	0.1	0.1	216VDC Half Wave	0.1	0.1
FB-1HE		0.2	0.2		0.2	0.2		0.2	0.2			
FB-2E		0.2	0.2		0.2	0.3		0.2	0.2			
FB-3E		0.4	0.4		0.4	0.3		0.4	0.3			
FB-5E		0.4	0.4		0.5	0.5		0.4	0.3			
FB-8E		0.4	0.4		0.5	0.5		0.4	0.3			
FB-10E	207VDC /104VDC Module <sup>[2]</sup>	2.0/1.0 <sup>[3]</sup>	2.0/0.8 <sup>[3]</sup>	216VDC /108VDC Module <sup>[2]</sup>	2.1/1.1 <sup>[3]</sup>	2.1/0.8 <sup>[3]</sup>	414VDC /207VDC Module <sup>[2]</sup>	1.0/0.5 <sup>[3]</sup>	1.0/0.4 <sup>[3]</sup>	432VDC /216VDC Module <sup>[2]</sup>	1.0/0.5 <sup>[3]</sup>	1.0/0.4 <sup>[3]</sup>
FB-15E												
FB-20												
FB-30												
ESB-250 <sup>[1]</sup>												

Table 4.44b continued... Brake Current for EP.NA Motor

Brake Model	575VAC, 50/60Hz		
	Vdc (V)	Idc (A)	Iac (A)
FB-1E	259VDC Half Wave	0.1	0.1
FB-1HE		0.2	0.2
FB-2E		0.2	0.2
FB-3E		0.4	0.3
FB-5E		0.4	0.3
FB-8E		0.5	0.4
FB-10E	259VDC Half Wave	0.4	0.3
FB-15E			
FB-20			
FB-30			
ESB-250 <sup>[1]</sup>			

Notes: [1] ESB-250 is available only with power module rated for use at 200VAC or 220VAC.

[2] Power module type brake control generates two voltage levels--1) high excitation voltage for initial release, and 2) lower holding voltage.

[3] 2 brake current values shown corresponding to the two voltage levels from power module--1) excitation current on initial power up, and 2) holding current.

Brake coil design will be specific to brake voltage specified at time of order. Check motor nameplate, to determine brake voltage rating.

FB-20 and FB-30 Brake Coil and Power Module come in two voltage ranges--1) 200-240VAC, and 2) 380-480VAC.

**Brakemotor: Brake Current Rating**

Table 4.45a Brake Current for Fractional Motor CE Motor

Brake Model	220VAC, 50/60Hz			230VAC, 50/60Hz			380VAC, 50/60Hz			400VAC, 50/60Hz		
	Vdc (V)	Idc (A)	Iac (A)	Vdc (V)	Idc (A)	Iac (A)	Vdc (V)	Idc (A)	Iac (A)	Vdc (V)	Idc (A)	Iac (A)
FB-01A	99VDC Half Wave	0.13	0.12	104VDC Half Wave	0.13	0.12	171VDC Half Wave	0.06	0.04	180VDC Half Wave	0.06	0.04
FB-02A		0.2	0.2		0.2	0.2		0.08	0.07			
FB-05A		0.2	0.2		0.2	0.2		0.1	0.1			
FB-1D		0.3	0.2		0.3	0.2		0.1	0.1			
FB-1E		0.3	0.2		0.3	0.2		0.1	0.1			

Table 4.45b Combination Table with Brakemotor Inertia

Brake Model	Motor Frame Sizes	Inertia WR2 lb-in2 (kg-m2)
FB-1E	N-80M	8.82 (0.00258)
FB-1HE	N-90S	13.5 (0.00396)
FB-2E	N-90L	15.4 (0.0045)
FB-3E	N-100L	33.4 (0.00978)
FB-5E	N-112M	71.4 (0.0209)
FB-8E	N-132S	105 (0.0306)
FB-10E	N-132M	154 (0.045)
FB-15E	N-160M	206 (0.0602)
FB-20	N-160L	393 (0.115)
FB-30	N-180MS	926 (0.271)
	N-180M	926 (0.271)
	N-180L	1170 (0.342)
ESB-250	N-200L	1380 (0.404)
	N-200LL	2550 (0.745)

Table 4.45c Brake Current for CE Motor

Brake Model	220VAC, 50/60Hz			230VAC, 50/60Hz			380VAC, 50/60Hz			400VAC, 50/60Hz						
	Vdc (V)	Idc (A)	Iac (A)	Vdc (V)	Idc (A)	Iac (A)	Vdc (V)	Idc (A)	Iac (A)	Vdc (V)	Idc (A)	Iac (A)				
FB-01A	99VDC Half Wave	0.13	0.12	104VDC Half Wave	0.13	0.12	171VDC Half Wave	0.06	0.04	180VDC Half Wave	0.06	0.04				
FB-02A		0.2	0.2		0.2	0.2		0.08	0.07							
FB-05A		0.2	0.2		0.2	0.2		0.1	0.1							
FB-1D		0.3	0.2		0.3	0.2		0.1	0.1							
FB-1E		0.2	0.2		0.2	0.2		0.2	0.2							
FB-1HE		0.5	0.4		0.5	0.4		0.2	0.2							
FB-2E		0.6	0.5		0.6	0.5		0.3	0.2							
FB-4E		1	0.7		1	0.8		0.4	0.3							
FB-5E		1	0.7		1	0.8		0.4	0.3							
FB-8E		1.1	0.9		1.1	0.9		0.5	0.4							
FB-10E		1.1	0.9		1.1	0.9		0.5	0.4							
FB-15E		1.1	0.9		1.1	0.9		0.5	0.4							
FB-20		198VDC /99VDC Module <sup>[2]</sup>	2.0/1.0 <sup>[3]</sup>		2.0/0.8 <sup>[3]</sup>	207VDC /104VDC Module <sup>[2]</sup>		2.0/1.0 <sup>[3]</sup>	2.0/0.8 <sup>[3]</sup>		342VDC /171VDC Module <sup>[2]</sup>	0.8/0.4 <sup>[3]</sup>	0.8/0.3 <sup>[3]</sup>	360VDC /180VDC Module <sup>[2]</sup>	0.9/0.5 <sup>[3]</sup>	0.9/0.4 <sup>[3]</sup>
FB-30																
ESB-250 <sup>[1]</sup>																
ESB-250 <sup>[1]</sup>																

Notes: [1] ESB-250 is available only with power module rated for use at 200VAC or 220VAC.

[2] Power module type brake control generates two voltage levels--1) high excitation voltage for initial release, and 2) lower holding voltage.

[3] 2 brake current values shown corresponding to the two voltage levels from power module--1) excitation current on initial power up, and 2) holding current.

Brake coil design will be specific to brake voltage specified at time of order. Check motor nameplate, to determine brake voltage rating.

FB-20 and FB-30 Brake Coil and Power Module come in two voltage ranges--1) 200-240VAC, and 2) 380-480VAC.

Technical Information

Technical Information

### Brakemotor: Optional Brake Torques

Table 4.46 Standard Brake Models

Brake Model	Motor Capacity		Braking Torque ft-lbs (N-m)	
	HP x 4P	kW x 4P	Standard	Optional
FB-01A	1/8	0.1	0.7 (1.0)	0.25 (0.34), 0.3 (0.4), 0.4 (0.54), 0.48 (0.65), 0.6 (0.8), 0.7 (1.0), 1.0 (1.4)
FB-02A	1/8 ~ 1/3	0.1 ~ 0.25	1.4 (2.0)	0.48 (0.65), 0.6 (0.8), 0.7 (1.0), 1.0 (1.4), 1.4 (2.0), 1.9 (2.6), 2.3 (3.1)
FB-05A	1/4 ~ 1/2	0.2 ~ 0.4	2.9 (4.0)	0.7 (1.0), 1.0 (1.4), 1.4 (2.0), 1.9 (2.6), 2.3 (3.1)
FB-1D	1/2	0.4	5.8 (7.5)	1.9 (2.6), 2.3 (3.1), 2.7 (3.7), 3.9 (5.3), 4.6 (6.2), 6.9 (9.4), 7.7 (10)
FB-2D	3/4	0.55	11 (15)	3.6 (4.9), 4.3 (5.8), 5.1 (6.9), 7.2 (9.8), 8.7 (12), 13 (18), 14 (19)
FB-3D	3/4	0.55	16 (22)	5.3 (7.2), 6.6 (9.0), 7.4 (10), 11 (15), 13 (18), 19 (26), 21 (28)
FB-1E	1	0.75	5.5 (7.5)	7.4 (10), 4.0 (5.5), 3.0 (4.0), 2.2 (3.0)
FB-1HE	1.5	1.1	8.0 (11)	11 (15), 5.5 (7.5), 3.7 (5.0), 2.2 (3.0)
FB-2E	2	1.5	11 (15)	15 (20), 8.0 (11), 5.5 (7.5), 3.7 (5.0)
FB-3E	3	2.2	16 (22)	22 (30), 11 (15), 7.4 (10), 4.4 (6.0)
FB-4E	4	3.0	22 (30)	30 (40), 16 (22), 11 (15), 7.4 (10)
FB-5E	5	3.7	30 (40)	40 (55), 22 (30), 15 (20), 7.4 (10)
FB-8E	7.5	5.5	40 (55)	53 (72), 30 (40), 22 (30), 15 (20)
FB-10E	10	7.5	59 (80)	80 (110), 44 (60), 30 (40), 15 (20)
FB-15E	15	11	80 (110)	110 (150), 59 (80), 44 (60), 29 (40)
FB-20	20	15	110 (150)	160 (220), 130 (175), 89 (120), 74 (100), 63 (85), 44 (60)
FB-30	25	18.5	140 (190)	160 (220), 110 (150), 89 (120), 74 (100), 44 (60)
	30	22	160 (220)	130 (175), 110 (150), 89 (120), 63 (85)
	40	30	150 (200)	120 (160), 74 (100)
ESB-250	50	37	195 (266)	275 (372), 235 (320), 155 (212), 120 (160), 78 (106)
	60	45	235 (320)	315 (426), 275 (372), 195 (266), 155 (212), 120 (160)

### Brakemotor Standard Wiring Connection

#### Models FB-01A through FB-15E, 230/460V, 60Hz or 575V, 60Hz

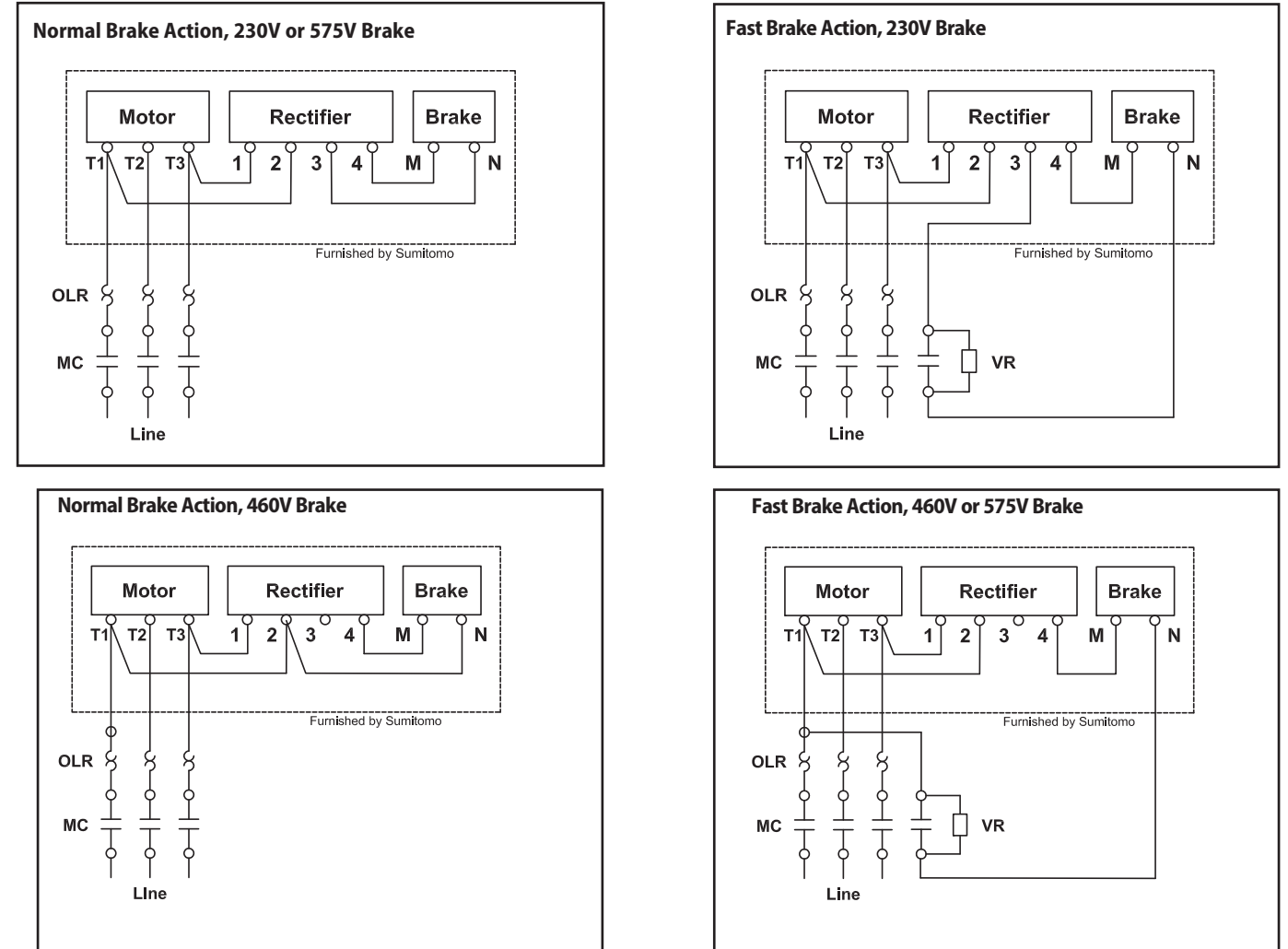

**Key:**  
**MC:** Electromagnetic Relay  
**OLR:** Overload or Thermal Relay  
**VR:** Varistor (protective device, refer to Varistor Specification Table)

### Brakemotor Standard Wiring Connection

Table 4.47 Varistor Specification Table

Operating Voltage		190-230V	380-460V	575V
Varistor Rated Voltage		AC260-300V	AC510V	AC604V
Varistor Voltage		430-470V	820V	1000V
Rated Watt	FB-01A, 02A, 05A	Over 0.4W	Over 0.4W	Over 0.4W
	FB-1E, 1D	Over 0.6W	Over 0.6W	Over 0.4W
	FB-1HE, 2E, 2D, 3D	Over 1.5W	Over 1.5W	Over 0.6W
	FB-3E, 4E	Over 1.5W	Over 1.5W	Over 0.6W
	FB-5E, 8E	Over 1.5W	Over 1.5W	Over 1.5W
	FB-10E, 8E	Over 1.5W	Over 1.5W	Over 1.5W
	FB-20, 30			Over 1.5W

**Brakemotor Inverter Wiring Connection**

Models FB-01A through FB-15E, 230/460V, 60Hz or 575V, 60Hz

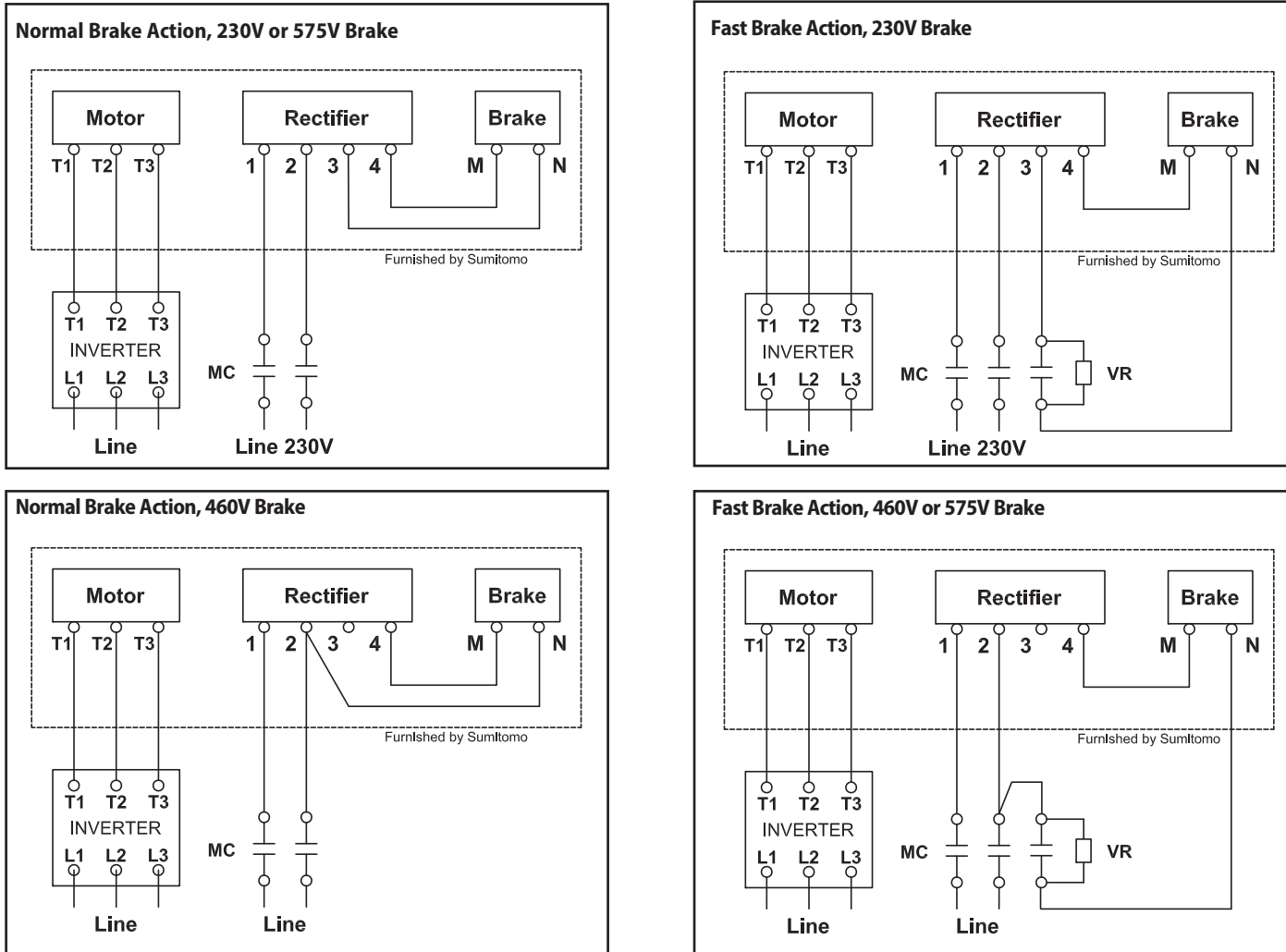

**Key:**  
**MC:** Electromagnetic Relay  
**OLR:** Overload or Thermal Relay  
**VR:** Varistor (protective device, refer to Varistor Specification Table)

**Brakemotor Inverter Wiring Connection, EP.NA Motor**

Table 4.48 Varistor Specification Table

Operating Voltage		190-230V	380-460V	575V
Varistor Rated Voltage		AC260-300V	AC510V	AC604V
Varistor Voltage		430-470V	820V	1000V
Rated Watt	FB-01A, 02A, 05A	Over 0.4W	Over 0.4W	Over 0.4W
	FB-1E, 1D	Over 0.6W	Over 0.6W	Over 0.4W
	FB-1HE, 2E, 2D, 3D	Over 1.5W	Over 1.5W	Over 0.6W
	FB-3E, 4E	Over 1.5W	Over 1.5W	Over 0.6W
	FB-5E, 8E	Over 1.5W	Over 1.5W	Over 1.5W
	FB-10E, 8E	Over 1.5W	Over 1.5W	Over 1.5W
	FB-20, 30			Over 1.5W

**Standard Wiring Connection for CE Motors**

Models FB-01A through FB-5E, 220/380V, 50Hz

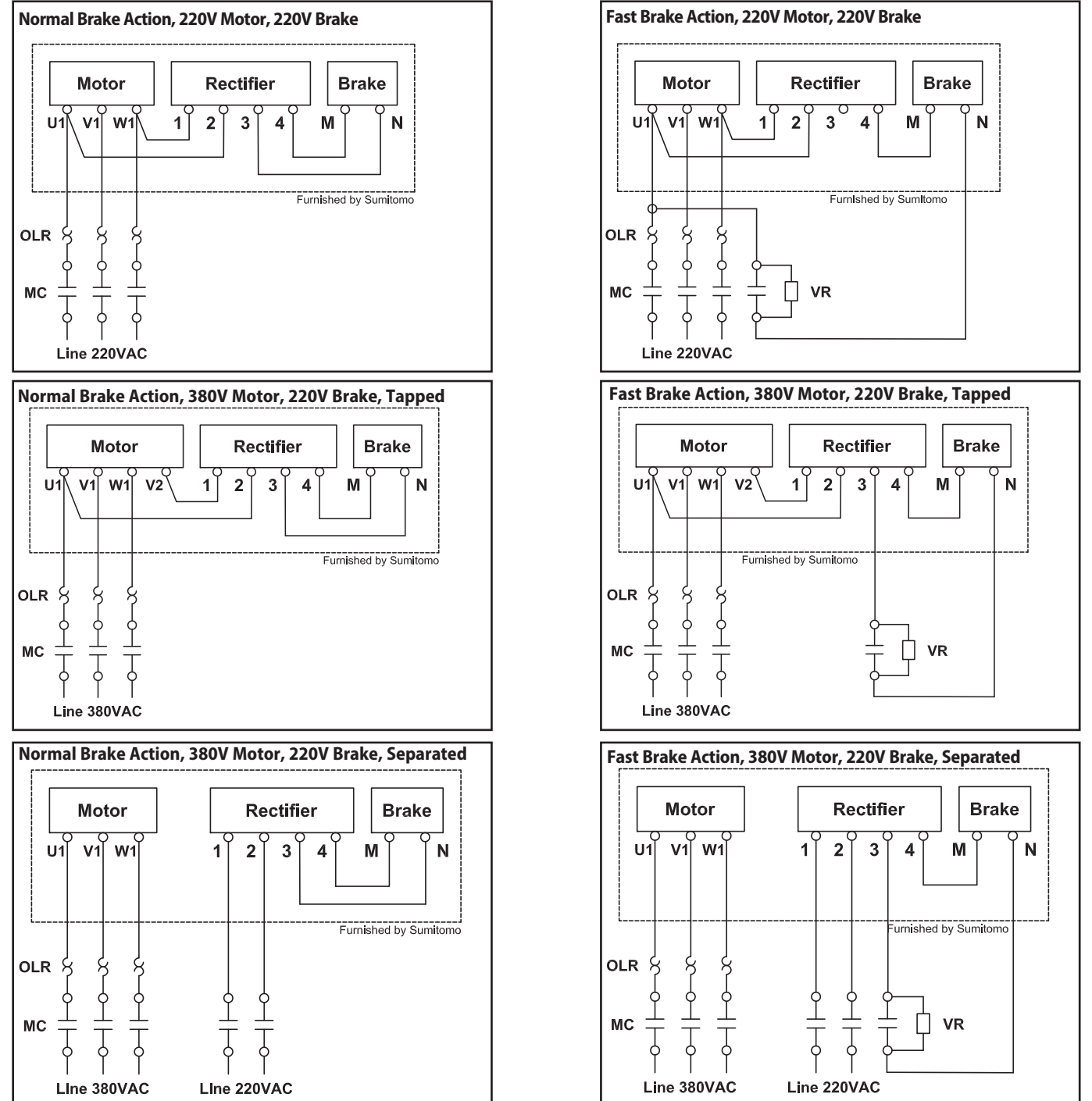

**Key:**  
**MC:** Electromagnetic Relay  
**OLR:** Overload or Thermal Relay  
**MCB:** Magnetic Circuit Breaker  
**VR:** Varistor (protective device, refer to Varistor Specification Table)

Technical Information

Technical Information

Standard Wiring Connection for CE Motors (continued)

Models FB-8E through FB-15E, 380V, 50Hz

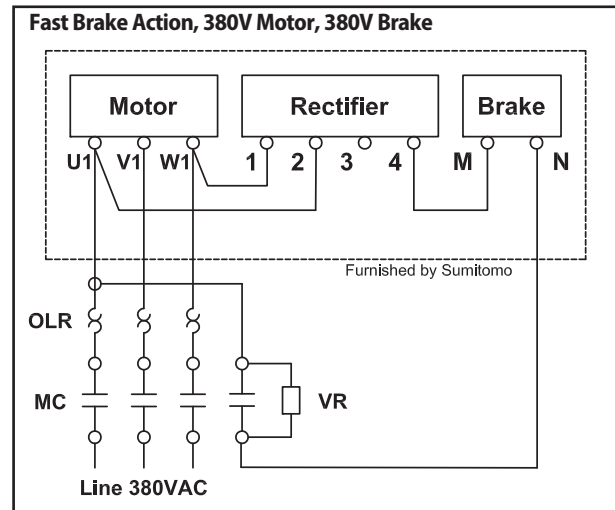
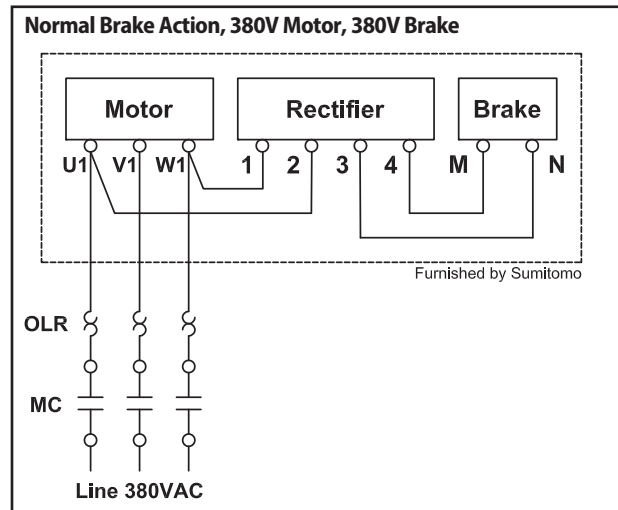

Models FB-01A through FB-15E with Inverter

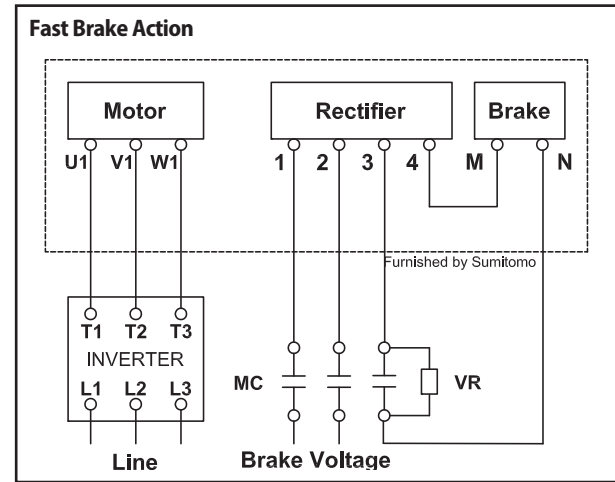
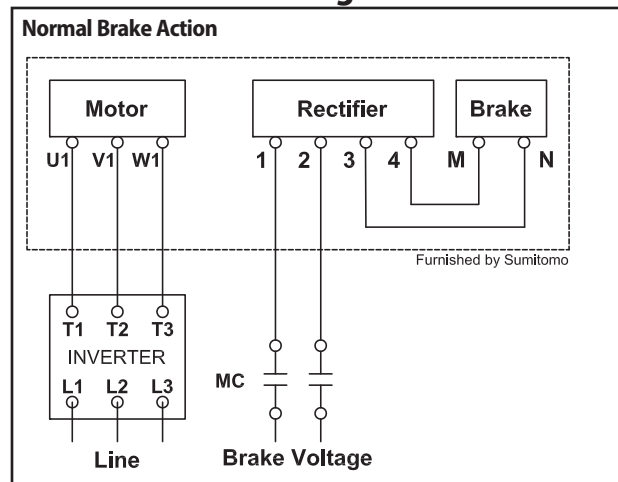

Key:

MC: Electromagnetic Relay    OLR: Overload or Thermal Relay    MCB: Magnetic Circuit Breaker  
VR: Varistor (protective device, refer to Varistor Specification Table)

Table 4.49a Standard CE Motor, Motor/Brake Voltage Table

Motor Power kW x 4P	Brake Model	Motor Voltage	Brake Voltage
0.1	FB-01A	220/380V, 50Hz	220V, 50Hz*
0.2, 0.25	FB-02A		
0.4	FB-05A		
0.55	FB-1D		
0.75	FB-1E		
1.1	FB-2E		
1.5	FB-1HE		
2.2	FB-3E		
3.0	FB-4E		
3.7	FB-5E		
5.5	FB-8E	380V, 50Hz	380V, 50Hz
7.5	FB-10E		
11	FB-15E		

Table 4.49b Varistor Specification Table

Operating Voltage	190-230V	380-460V	575V	
Varistor Rated Voltage	AC260-300V	AC510V	AC604V	
Varistor Voltage	430-470V	820V	1000V	
Rated Watt	FB-01A, 02A, 05A	Over 0.4W	Over 0.4W	Over 0.4W
	FB-1E, 1D	Over 0.6W	Over 0.6W	Over 0.4W
	FB-1HE, 2E	Over 1.5W	Over 1.5W	Over 0.6W
	FB-3E, 4E	Over 1.5W	Over 1.5W	Over 0.6W
	FB-5E, 8E	Over 1.5W	Over 1.5W	Over 1.5W
	FB-10E, 8E	Over 1.5W	Over 1.5W	Over 1.5W
	FB-20, 30			Over 1.5W

Wiring for Brake Models FB-20 / FB-30 - EP.NA Motor and IE3 CE Motor

FB-20 and FB-30 Brake Wiring, 480VAC or less

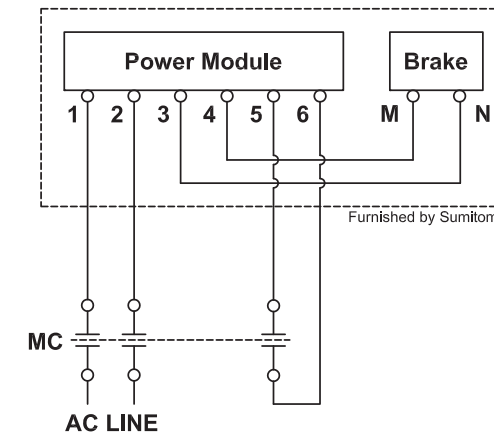

FB-20 and FB-30 Brake Wiring, 575VAC

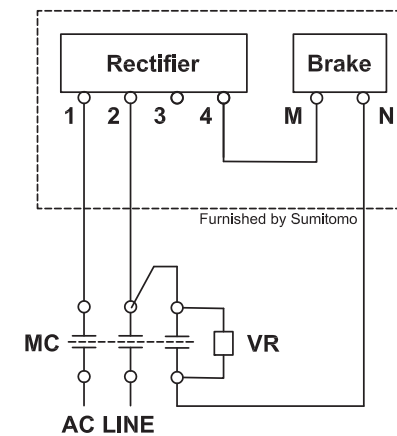

Key:

MC: Electromagnetic Relay  
VR: Varistor (protective device, refer to Varistor Specification Table)



**Brake Rectifiers and Brake Power Modules**

**Table 4.50 Brake Rectifiers for EP.NA Motors**

Brake Type	Motor Power HP (kW) x P	230V/460V Rectifier		575V Rectifier	
		Model Number	Part Number	Model Number	Part Number
FB-1E	1 x 4	25FW-4FB3	EW107WW-01	10F-6FB3	EW104WW-01
FB-1HE	1.5 x 4				
FB-2E	2 x 4				
FB-3E	3 x 4				
FB-5E	5 x 4				
FB-8E	7.5 x 4				
FB-10E	10 x 4				
FB-15E	15 x 4				
FB-20	20 x 4				
FB-30	25 x 4				
	30 x 4				
	40 x 4				

**Table 4.51 Brake Rectifiers for IE3 CE Motors**

Brake Type	Motor Power HP (kW) x P	220V Rectifier		380V Rectifier	
		Model Number	Part Number	Model Number	Part Number
FB-1E	0.75 x 4	10F-2FB2	MP983WW-01		
FB-1HE	1.1 x 4				
FB-2E	1.5 x 4				
FB-3E	2.2 x 4				
FB-4E	3.0 x 4				
FB-5E	3.7 x 4 4.0 x 4			05F-4FB2	MP985WW-01
FB-8E	5.5 x 4			15F-4FB1	EW397WW-01
FB-10E	7.5 x 4				
FB-15E	11 x 4				

**Table 4.52 Brake Power Modules for EP.NA Motors and IE3 CE Motors**

Brake Type	Motor (HP x P)	170 ~ 300VAC Module		380 ~ 480VAC Module	
		Model Numbers	Part Number	Model Numbers	Part Number
FB-20	20 x 4	13SR-2	EY570WW-01	10SR-4	MQ003WW-01
FB-30	25 x 4				
	30 x 4 40 x 4				

Company warrants that (i) all new equipment and parts (collectively, "Equipment") sold by Company will conform to printed drawings and specification sheets issued by Company and (ii) are free of defects in material and workmanship for the time period shown in Table 4.53. The warranty period commences on the date of shipment of the Equipment by Company.

If, within the warranty period, Company receives from Buyer written notice of any alleged defect in any of the Equipment and, if the Equipment is found by Company not to conform with these warranties (after Buyer has provided Company a reasonable opportunity to perform any appropriate tests on the allegedly defective Equipment), Company will, at its sole option and expense, either repair or replace the Equipment. In all instances, Company reserves the right to require Buyer to deliver the Equipment for repair or replacement to a designated service center and require Buyer to pay all charges for inbound and outbound transportation and for services of any kind, diagnostic or otherwise, excepting only the direct and actual cost of Equipment repair or replacement. Warranty coverage is limited to parts and labor and does not include travel and other expenses. Buyer applications and use of the Equipment may require installation of safety features. Buyer is responsible for furnishing and installing guards or other safety equipment needed to protect operating personnel, even though such equipment may not be furnished by Company with the Equipment purchased. Equipment supplied, but not manufactured, by Company is warranted only to the extent of the original manufacturer's warranty.

**Table 4.53 - Product Warranty**

Product	Warranty Period (After Shipment)	Components Excluded
Cyclo® Speed Reducers and Gearmotors	2 Years	Bearings and Seals
Cyclo® Bevel Buddybox Speed Reducers and Gearmotors	2 Years	Bearings and Seals
Cyclo® Helical Buddybox Speed Reducers and Gearmotors	2 Years	Bearings and Seals
Fine Cyclo® Speed Reducers	2 Years	Bearings and Seals
Beier® Variator Mechanical Adjustable Speed Reducers	2 Years	Bearings and Seals
Hyponic® Speed Reducers and Gearmotors	2 Years	Bearings and Seals
Hedcon® Double Enveloping Worm Gear Speed Reducers	2 Years	Bearings and Seals
Helical Shaft Mount Speed Reducers	2 Years	Bearings and Seals
Rhytax®	2 Years	Bearings and Seals
IB Series Servo Gearheads	1 Year	Bearings and Seals
Astero Gearmotors	1 Year	Bearings and Seals
Variable Frequency Inverters	1 Year	---
Paramax® Speed Reducers	2 Years	Bearings and Seals
Compower Planetary Speed Reducers	1 Year	Bearings and Seals
Hansen UniMiner	2 Years	Bearings and Seals
Hansen P4	2 Years	Bearings and Seals
Parts	1 Year	---
Repairs	1 Year	Bearings and Seals

Technical Information

Technical Information



Cyclo® BBB4

Technical Information

Cyclo® BBB4

Technical Information

---

Page intentionally left blank.

Cyclo® BBB4

Technical  
Information