



Sumitomo Drive Technologies



Sumitomo Drive Technologies

A global power transmission solutions provider. With facilities strategically located throughout the world, providing comprehensive products and services in your region.

Headquarters



4200 Holland Blvd
Chesapeake, VA 23323

email: SMA.CustomerService@shi-g.com
phone: 757-485-3355



Why choose Sumitomo Drive Technologies forest products for your applications?

We offer the toughest drives available to meet the harshest demands.

We know Forest Products

Forest Products plays an important role in our everyday needs. Renewable materials are an essential player in efforts to keep our planet clean. We see sustainable materials in our homes, the electricity that powers our homes, and the products we use every day in our homes.

Sumitomo Drive Technologies understands the importance renewable Forest Products have had in the past and shares the vision that the Forest Products Industry will play an important role in the future. We have the know-how, the tools, and the experience to grow with you.

With addition of the Hansen product line, and significant fabrication and machining investments, Sumitomo has positioned itself as a self-reliant vendor for your needs. We can take the guesswork out of your difficult application problems using our state of the art calculation programs. Sumitomo can easily provide detail calculations showing you gear ratings, bearing life and sump temperature.

From log handling to manufacturing and distribution of finished forest products, Sumitomo can provide gearbox solutions with lower operating costs. We have local experienced employees and representatives ready to visit your site and walk through your application details. We pride ourselves on having the “dirtiest” salesmen in the industry.

The Right Gearbox for the Right Job

We are interested in selling the right gearbox for the application—not just any gearbox in our inventory. **Sumitomo Drive Technologies has the products that perform.**

Standard large industrial gearboxes are pre-engineered and manufactured to be assembled from our inventory. Local engineering, manufacturing, and assembly allow us to customize these products to meet your needs.

Our large industrial gearboxes also have various upgrades and performance monitoring products to keep each gearbox in action. By following our preventative maintenance procedures, you ensure your gearbox lives a long life. If your gearbox has an issue, our experienced network of aftermarket experts are always available. Plus, with one of the longest warranties in the gearbox industry, your operation is well protected. We ask the right questions to ensure you have the correct industrial gearbox for your specific application. Customer experience is our top priority, and we want to ensure that our customers can get the modifications or custom options they desire.



P PARAMAX® 9000

- AGMA Class 11+ Gearing
- Power Dense
- 25° Pressure Angle Gear Teeth
- Welded Steel and Ductile Housing Available



V HANSEN VERTICAL P4

- Standard Drywell
- Horizontally Split Housing
- Maintenance Free Oil-Lock®
- Specific Bearings



P4 HANSEN P4

- Rugged Housing
- Large Lube Capacity
- Modular Design
- Contactless High Speed Seal



B4 CYCLO® BBB 4

- Taper-Grip® Bushing
- Compact Design
- Multiple Input Styles



C CYCLO® 6000

- Cycloidal Technology
- Optimal Efficiency
- Hi-Shock Overload Resistance
- Mill Duty Upgrades Available

Old gearboxes are high maintenance and use outdated technology and parts.

Modern gearing technology offers lower maintenance and safer operating options.

The Challenge:

Repairing obsolete gearboxes is impractical and an unreliable practice that we see often. Outdated gearboxes can have many modifications throughout their life including ratio, handing, and HIGHER input speed. This can make replacement difficult.

Obsolete Equipment Problems:

- Older technology components
- Made-to order gearing (non-stock)
- Long delivery for exact OEM replacement
- High replacement cost for OEM design
- Lower horsepower ratings than current design
- Bearing bores are difficult to repair

The Solution:

Sumitomo can engineer a dimensional drop-in with a higher service factor, lower cost, and quick delivery. A Sumitomo representative will provide hands-on assistance to provide solutions to the customer, including repair, horsepower interchange, ordering an OEM duplicate or a custom-engineered Sumitomo unit that could simply drop into the existing footprint.

Sumitomo Problem Solvers:

- Sumitomo offers many custom solutions
- Hands-on assistance
- Using industry-standard components for a shorter lead time.
- An in-house fabricated steel housing provided a drop-in solution



Conveyor Belt



C P B4

Screw Conveyor



B4

Mixer/Aerator/Flotation



P4 B4

Pulper



V

Radial Stacker

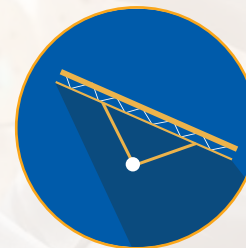

P B4

Kiln



C P P4

Pump



C P P4

Log Carriage



C P

Debarker



C P

Chipper/Shredder



C P4

Winder



P P4

Digester



P P4

Rotary Airlock/Chip Meter



C P B4

Roll Drive



P P4

OPTIDRIVE E3

GENERAL PURPOSE DRIVE

Compact, robust, and reliable general purpose drive.

Focused on ease of use, Optidrive E3 provides **unrivalled simplicity** of installation, connection, and commissioning, allowing the user to benefit from **precise motor control** and **energy savings** within minutes.

Available in **IP66/Nema 4X outdoor rating** with rigid polycarbonate plastics specifically chosen to **withstand degradation** by ultraviolet (UV), greases, oils, and acids. Also, robust enough not to be brittle at -20°C (-4°F).

- 150% Overload for 60 secs
- 175% Overload for 2.5 secs
- 98% Typical Efficiency

 Compliant with international standards.



ENCLOSURES

FAST CONNECTION

5mm rising clamp terminals with captive screws.

KEYHOLE MOUNTS

QUICK REFERENCE

Integrated help card.

OPTISTICK SMART

A rapid commissioning tool that allows copying, backup, and the restoring of drive parameters.



DUAL ANALOG INPUTS

SPECS



HP RATING
Up to 350 HP
(250 kW)



POWER OPTIONS
Single-Phase: 200-240V
3-Phase: 200-600V



TORQUE
Up to 200%
(From Zero Speed)



INTEGRATED DISPLAY

LED multi-language text display.

INTEGRATED CABLE MANAGEMENT

PLUGGABLE CONTROL TERMINALS

FANS

High quality long-life fans.

OPTIDRIVE P2

HIGH PERFORMANCE DRIVE

High-performance **variable frequency drive** for standard induction and permanent magnet motors.

Its **user-friendly interface** and high performance make it perfect for tackling the most demanding applications smoothly.

Extensive I/O and communications **interface capabilities** ensure the drive can be **integrated quickly and efficiently** into a wide variety of control systems.

Dedicated Hoist Mode Operation with motor holding brake control makes it perfect for marine and elevator applications.

- 200% Overload for 4 secs
- 98% Typical Efficiency
- Integral Brake Transistor

We take asset management seriously,
because we know you do.

Avoid catastrophic failure, minimize risk
and increase machine uptime.

System Management And Reliability Technology (SMART)

SMART is a range of products and reducer options that were developed to help end users in their reliability and asset management initiatives within their plant's daily operations.



Reliability Monitoring

These reducer option packages will help in the consistent collection of data. For Vibration analysis, as well as oil condition and cleanliness testing

Large Industrial Gearboxes

OPTIONS*

Opt 1: Machined Accelerometer Mounting Pads Only

Opt 2: Opt 1 + Accelerometers Wired to Junction Box

Opt 3: Opt 2 + Outputs to Customer PLC or DCS

YOU THINK!



Condition Monitoring

Fully customizable systems provide real time condition data of any piece of rotating equipment. Providing an accurate condition signal without the need for further analysis

All Gearboxes

OPTIONS **

Vibration + Temperature Input

Vibration + Oil Level Input

Vibration + Oil Condition

WE THINK!

CycloSMART® Benefits

- **Safe**
Monitor assets from the safety of your desk via networked connections
- **Predictive**
Machine diagnostics for early warning and detection to avoid failure
- **Optimization**
Customizable systems to meet many different application needs
- **Expandable**
Multi-reducer monitoring
- **Reliable**
Schedule machine downtime to avoid lost production
- **Cost-Effective**
Lower overall ownership cost

the **CHECK** 
ENGINE LIGHT for
SPEED REDUCERS

* All DriveSMART® options include: Oil sampling pitot tube, and Oil Breather package that incorporates oil fill and drain ports.

** All CycloSMART® systems are customizable with many different options for data monitoring. Examples are shown.

Learn more at: SumitomoDrive.com/CycloSmart



Our team of factory-trained technicians has centuries worth of experience.

Connecting you to the Service you need

Experts in Service

Global Support, Local Service

Our personnel are the industry's most versed gearbox problem solvers. We provide both standard and tailored services, for maximum gearbox life.



With a vast network of engineers and gearing experts, there is no problem we can't handle.

In addition to our extensive network, LUFTEX Gears Manufacturing and Services provide unmatched capabilities and expertise in the area of custom gearbox repair and service. With a **60-ton crane capacity and 41 ft hook height, no gearbox is too big for us to handle.**

Whether custom gear manufacturing or on-site gearbox repair, let our team at LUFTEX keep your operation running.

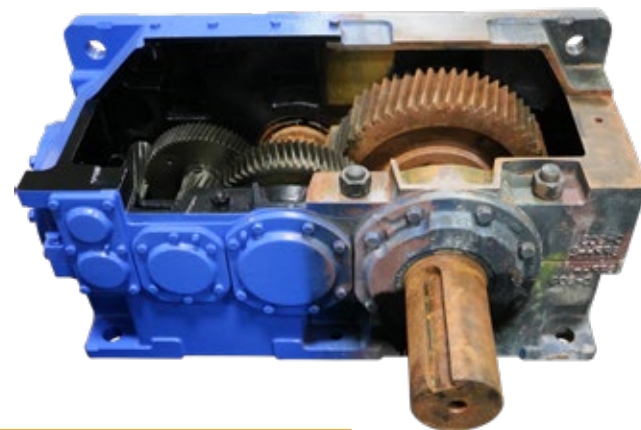

Repairs

Scheduled & Emergency Repair

Repair services for all your related gearbox needs and 24-72 hour turnaround to the original factory specifications and warranty using Sumitomo-manufactured parts.

Extended warranty programs are available upon request.

Root Cause Investigation

Product Support

We'll apply a wide range of approaches, tools, and techniques to uncover the causes of your problems.

Field Services

For Your Convenience

Most of the services offered and customized training can be performed on location.

Custom Solutions

Our gearing engineers can design upgrade options for existing units to increase performance or design complete custom drop-in replacement units that fit into an existing footprint and envelope.

On-Site Solutions

Our team of experienced technicians and engineers can travel to your location to complete your requested repairs and maintenance. These solutions can minimize downtime and get your operation back up and running.

Flexible Solutions for Your Business Needs

SERVICE SOLUTIONS

- Engineering Design and Analysis
- Reverse Engineering of Customer Components
- Design Upgrade Recommendations
- Disassembly and Evaluation of Gear Units
- NDT Inspections
- Manufacturing of Gear Components
- Full-Service Machine Shop
- On-Site Technical Support for Customer Repairs
- Field Service Rebuilds and Repairs
- Commissioning and Start-Up Services
- Root Cause Investigations
- Condition Monitoring

Repair and Rebuild Solutions

Scheduled or emergency repairs can be completed on time and within budget by our Aftermarket team. Utilizing OEM parts and in-house machining and manufacturing capabilities allows us to meet your needs for a quality and timely repair.



Retro-Fit units with transition bases allow us to match your existing footprint.

Custom drop-in units made to match existing unit's critical dimensions.

Retro-Fits and Drop-Ins

Whatever your requirements, we have a solution for you. Sumitomo offers customized bases which allow our units to match the footprint of an array of existing applications and drop-in gear drives to upgrade and replace competitor units.

With a wide range of options, our engineers can replace your unit with minimum impact while delivering a premier product with performance and reliability.

Retro-Fit

Match existing footprint

A custom transition base will position the new low-speed shaft to be in the EXACT same position as the original low-speed shaft. Our retrofits provide an excellent balance between the cost savings of a standard gearbox and the benefits of minimal on-site modifications.

Typically, only relocating the motor mount is required for this option. We offer motor mounting options to help minimize the impact of relocating the motor mount, such as flanged motor adapter for c-face or d-flange motors.

Options might include a special low-speed shaft diameter or length and motor lantern.

The red circles in the diagram represent the existing bolt pattern of a customer's unit. The transition base is fabricated to match the height, ensuring alignment of the low-speed shaft to the machine shaft.

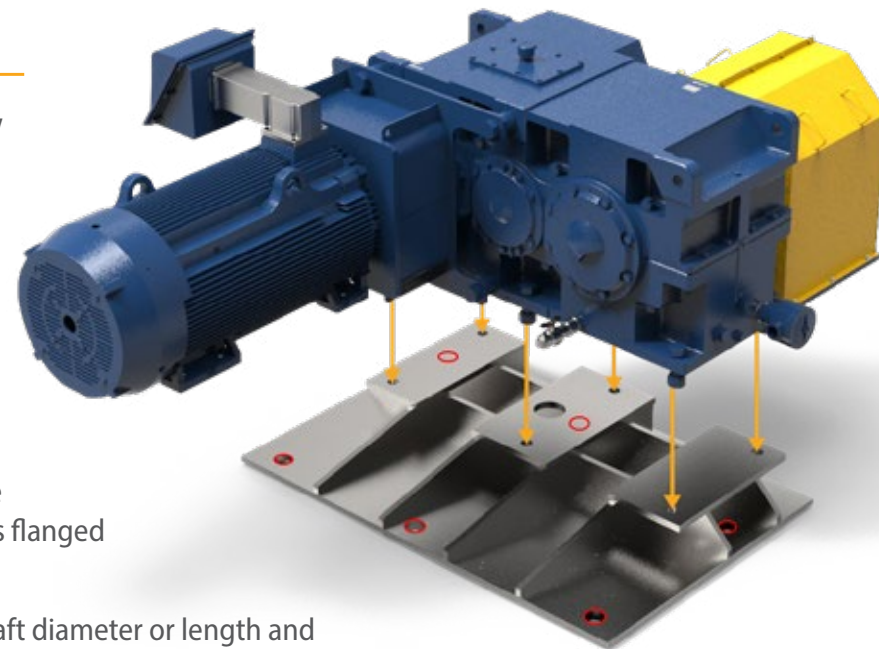

Drop-In

Match existing unit's critical dimensions

Sumitomo's installation-ready units are designed specifically to drop-in to existing applications with no problems. Our expert engineers understand that on-site modifications or re-engineering your system is not always an option.

With downtime being such a critical factor in your operation, let us install one of our custom drop-in units.

Our stress-free units can have your application back up and running in no time. We offer fabricated steel housings, custom baseplates, custom gearing and shafting and more!

This product will literally drop-in to place; same footprint, same shaft positions!

Specialty Units

For non-standard gearing and custom ratios, we offer special customized units to fit in any application. From custom paint to intricate gearbox lubrication systems, our team of engineers will make sure all of your custom gearbox needs are met.

We have exceptional engineering and factory capabilities to support you on your gearbox needs.

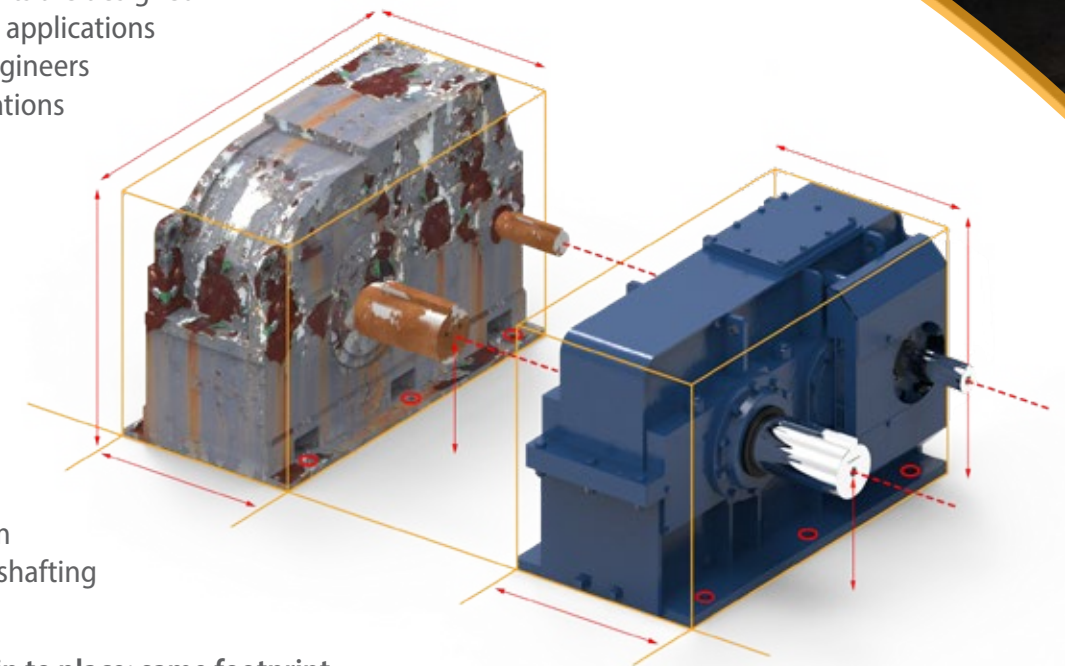

Our factory capabilities support all of your gearbox needs.

The most reliable and highest quality products backed by a 400 year heritage.

Why Sumitomo?

Our 400 Year Heritage

The history of the Sumitomo Group started more than 400 years ago when Masatomo Sumitomo opened a book and pharmacy store in the city of Kyoto, Japan. Today, the Sumitomo Group consists of more than 20 companies who share the Sumitomo Emblem as well as many common values and ideals.

Devoted to Quality

In addition to one of the most comprehensive product lines of any power transmission company, we offer the most reliable and highest quality products available in the industry. Whether it's product development or manufacturing processes, our Quality culture resonates through our entire global network.

Committed to our Employees and the Community

We recognize our employees are our most valuable asset. They are the driving force behind our innovative products, our ability to support our customers, and our commitment to continuous process improvement. We strive to be a valuable member of society and take pride in the contributions we make to our communities across North and South America.

Dedicated to Innovative Manufacturing

With more than a century of expertise in manufacturing, our global capabilities are unmatched in the industry. We have manufacturing and assembly facilities on every continent and continue to make investments in our manufacturing technologies to maintain our position as a leader in innovation.

Centers of Excellence

Our Centers of Excellence offer customers a nationwide support network. From inventory distribution to manufacturing to assembly, we have the team to ensure high quality, responsiveness, on-time delivery, and quick lead times.



Chesapeake, VA

Manufacturing, Support, Inventory, and Training

Our Western Hemisphere headquarters has 360,000 sq ft of manufacturing space, and cutting-edge technology. Centralized inventory distribution with a Foreign trade zone (FTZ), focused on inventory optimization, motor assembly, and hands-on training at our Power Institute.



Verona, VA

Industrial Gearbox Production

This purpose-built facility is specifically designed to handle the assembly of our large industrial gearboxes.



Lufkin, TX

Manufacturing and Services

This 32,000 sq ft facility handles gear manufacturing, gearbox repairs, and reverse engineering.



Glendale Heights, IL

Gearmotor Assembly and Support

Houses our state-of-the-art paint system for our SHIELD360® packages for Cyclo®, BuddyBox®, and Hyponic®.