

# Sumitomo Drive Technologies

**Sumitomo Machinery Corporation of America**  
**Headquarters & Manufacturing**  
 4200 Holland Boulevard, Chesapeake, VA 23323



**Sumitomo Machinery Corp. of America**  
 Chesapeake, VA  
 Glendale Heights, IL  
 Verona, VA

Phone: +1.757.485.3355  
 +1.630.752.0200  
 +1.540.213.2442

Fax: +1.757.485.7490  
 +1.630.752.0208  
 +1.540.213.2222

**SM Cyclo de Mexico, S.A. de C.V.**  
 Monterrey  
 Guadalajara  
 Ciudad de México

+52.81.8144.5130  
 +52.33.3675.4323  
 +52.55.2282.8700

+52.81.8144.5130 ext. 3109  
 +52.33.3675.4418  
 +52.55.2282.8700

**SM Cyclo of Canada, Ltd.**  
 Toronto, ON  
 Vancouver, BC

+1.905.469.1050  
 +1.604.525.5403

+1.905.469.1055  
 +1.604.525.0879

**SM Cyclo Colombia, S.A.S.**  
 Bogotá

+57.1.300.0673  
 +57.1.300.0673 ext. 105

**Sumitomo Indústrias Pesadas do Brasil Ltda.**  
 São Paulo

+55.11.4403.9292  
 +55.11.4403.9292

**SM Cyclo de Chile Ltda.**  
 Santiago  
 Antofagasta  
 Concepción

+56.2.2892.7000  
 +56.5.5256.1611  
 +56.41.246.9806

+56.2.2892.7001  
 +56.5.5256.1616  
 +56.41.246.9171

**SM Cyclo de Guatemala Ensambladora, Ltda.**  
 Guatemala

+502.6648.0500  
 +502.6648.9171

**SM Cyclo de Argentina, SA**  
 Buenos Aires

+54.3327.45.4095  
 +54.3327.45.4099

## World Headquarters

Japan  
 Sumitomo Heavy Industries, Ltd.  
 Power Transmission & Controls Group  
 ThinkPark Tower, 1-1, Osaki 2-chome,  
 Shinagawa-ku, Tokyo 141-6025 Japan  
 Tel: +81-367-37-2511 • Fax: +81-368-66-5160

[www.sumitomodrive.com](http://www.sumitomodrive.com)  
**E-mail: [customercare@suminet.com](mailto:customercare@suminet.com)**

Catalog 07.601.50.010  
 ©2024 Sumitomo Machinery Corporation of America Printed in USA

Sumitomo Drive Technologies

CYCLO® HBB HELICAL BUDDYBOX®

Gearmotor and Speed Reducers

# Sumitomo Drive Technologies

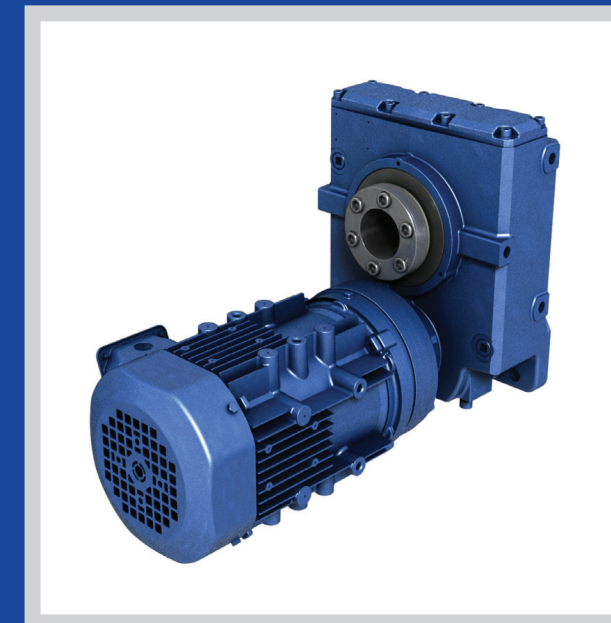

**CYCLO® HBB**  
**HELICAL BUDDYBOX®**  
 Gearmotor and Speed Reducers



## EPNA Motors

Enhanced Performance (EPNA) integral motors represent exceptional value to customers. To maximize the performance of the motors, a host of advanced features has been developed providing tangible benefits to the users.

### All in one

To simplify transactions throughout the continent, North American version (.NA) features standard multiple listings including DOE, UL and CSA, along with CE marking. Other versions are available for premium performance with European 50 Hz voltages.

### Exceptionally long life

Our Premium Efficient Motors feature lower temperature rise and robust class "F" insulation. The combination of those attributes yield reduced motor operating temperatures that exponentially increase the thermal life of the insulation. In order to match the longer insulation life, deep groove ball bearings have been incorporated to further extend the life of our products.

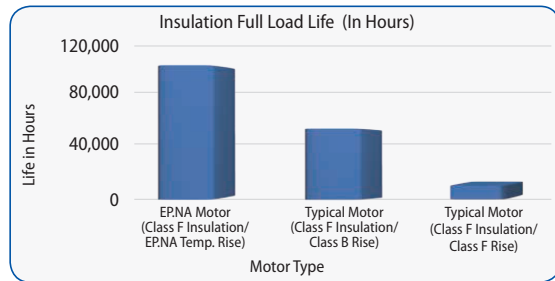

### Eco friendly

Premium efficiency, mandated by the DOE (Department of Energy, USA), shrinks the carbon footprint by delivering more torque at the same level of energy consumption. Higher starting torques may allow smaller motors to be selected for some applications.

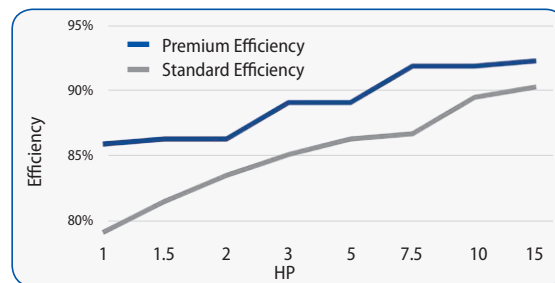

### Cost-effective

The premium efficiency design is cost-effective in reducing energy consumption throughout the full speed range, resulting in a lower total lifecycle cost.

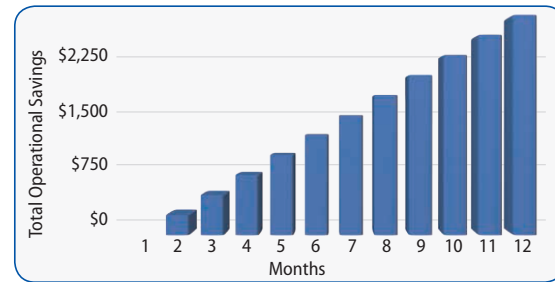

The assumptions for the study are as follows:  
 9.8 cents of a dollar per kWh • 8600 operating hours annually • A 7.5 kilowatt motor (10 HP) • IE3 motor costing 25% more than the IE1 motor • IE3 premium efficiency motor being 2.8% more efficient than the IE1 standard efficiency motor

### Inverter duty

All of the motors feature corona resistant magnet wire that resists the voltage spikes that are inherent to the widely applied IGBT inverters and extends insulation life. Inverter duty brake motors are also available. The non-brake motors are suitable for a 10:1 turndown. The advanced fan design helps to keep the motor running cool at lower input speeds.

### Optimized Geometry

Increasing motor size is one of several techniques to reduce losses and achieve premium efficiency. Sumitomo optimized its existing external envelope while still accommodating a large motor core. The result is a compact premium efficient motor.

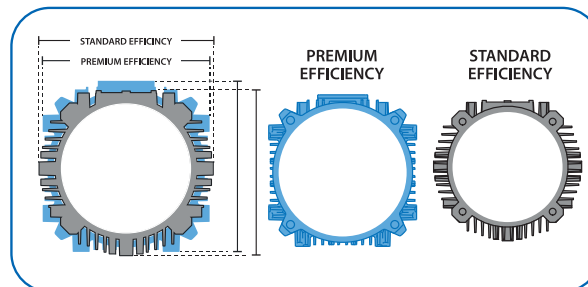

## For applications ranging from robotics to bulk material handling.

Sumitomo offers a comprehensive lineup of premier power transmission products to keep customers' operations performing at their best. This includes the broadest range of the most reliable and highest quality speed reducers, gearmotors and large industrial gearboxes available in the industry.

	Torque (lbs-in)	8.85	88.5	885	8,850	88,507	885,075	8,850,746
Precision / Motion Control	IB P1 Series		71 - 1,354 lb-in (8 - 153 N-m)					
	Servo 6000		142 - 4,425 lb-in (16 - 500 N-m)					
	Fine Cyclo®			1,318 - 45,492 lb-in (149 - 5,140 N-m)				
Inline	Cyclo® 6000		55 - 603,000 lb-in (6.2 - 68,130 N-m)					
Right Angle	Hyponic®		44 - 13,100 lb-in (5 - 1,480 N-m)					
	Cyclo® BBB 5 Series			1,088 - 45,450 lb-in (123 - 5,140 N-m)				
	Cyclo® BBB 4 Series			1,088 - 159,983 lb-in (123 - 17,400 N-m)				
Offset Parallel	Cyclo® HBB			1,080 - 75,800 lb-in (122 - 8,564 N-m)				
	Helical Shaft Mount			3,900 - 388,884 lb-in (440 - 43,938 N-m)				
Large Industrial	Paramax® 9000			23,012 - 4,885,614 lb-in (2,600 - 552,000 N-m)				
	Hansen P4 Single-Stage			40,000 - 1,504,000 lb-in (4,519 - 170,000 N-m)				
	Hansen P4 Multi-Stage			46,000 - 9,735,825 lb-in (5,200 - 1,100,000 N-m)				
	Hansen P4 Vertical			105,000 - 7,250,000 lb-in (11,863 - 819,000 N-m)				
	Hansen P4 UniMiner			122,000 - 889,000 lb-in (13,784 - 100,445 N-m)				
	Seisa Drives			DP1000: 40,713 - 6,515,000 lb-in (4,600 - 736,000 N-m) Mill Drives: 7,806,362 - 42,625,212 lb-in (882,000 - 4,816,000 N-m)				
	Torque (N-m)	1	10	100	1,000	10,000	100,000	1,000,000



Product Configurator: [www.sumitomodrive.com/Configurator](http://www.sumitomodrive.com/Configurator)

Sumitomo Drive Technologies' online product Configurator streamlines the selection process, enabling you to build **our power transmission products for your specific application.**

Configure your Sumitomo Drive Technologies products today at [www.sumitomodrive.com/Configurator](http://www.sumitomodrive.com/Configurator)

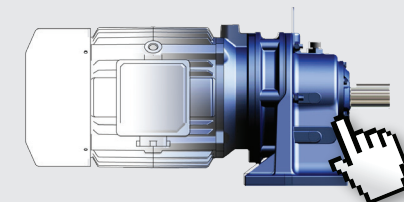

Scan with a QR code reader to login!

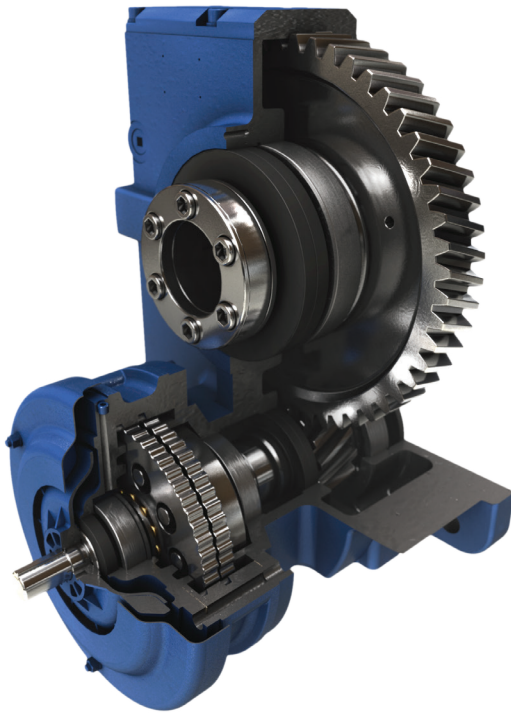

## Table of Contents

### 1. General Information

#### 2. Speed Reducers

How to Select .....	2.2
Configure a Model Number (Nomenclature) . . .	2.4
AGMA Load Classifications. ....	2.6
Selection Tables .....	2.8
Single Reduction .....	2.8
Double Reduction .....	2.12
Dimensions .....	2.14
C-Face Single Reduction .....	2.14
C- Face Double Reduction .....	2.16
Quill Single Reduction .....	2.19
Quill Double Reduction .....	2.20

#### 3. Gearmotors

How to Select .....	3.2
Configure a Model Number (Nomenclature) .....	3.4
AGMA Load Classifications .....	3.6
Selection Tables .....	3.10
Single Reduction .....	3.10
Double Reduction .....	3.62
Dimensions .....	3.80

#### 4. Options

Keyed Hollow Shaft .....	4.2
Output Flange .....	4.2
Torque Arm "T" Type .....	4.4
Torque Arm Clevis Type .....	4.4
Screw Conveyor Drive .....	4.5
Industry Packages .....	4.6

#### 5. Technical Information

Exact Ratios .....	5.2
Special Load Guidelines .....	5.7
Lubrication .....	5.11
Motor .....	5.15
Standard Wiring .....	5.28
Brakemotor .....	5.31
Brakemotor Wiring .....	5.36
Warranty .....	5.42

► Flexible configurations

• Mounting Options:

- Flange
- Face
- Torque Arm
- Screw Conveyor

Double output seals prevent lubricant leaks and protect from contamination

Patented keyless, steel Taper-Grip® bushing allows for quick and easy mounting and removal. Installs from either side

Utilizes all Cyclo® input modifications: C-Face input, integral gearmotor, brakemotor or servomotor

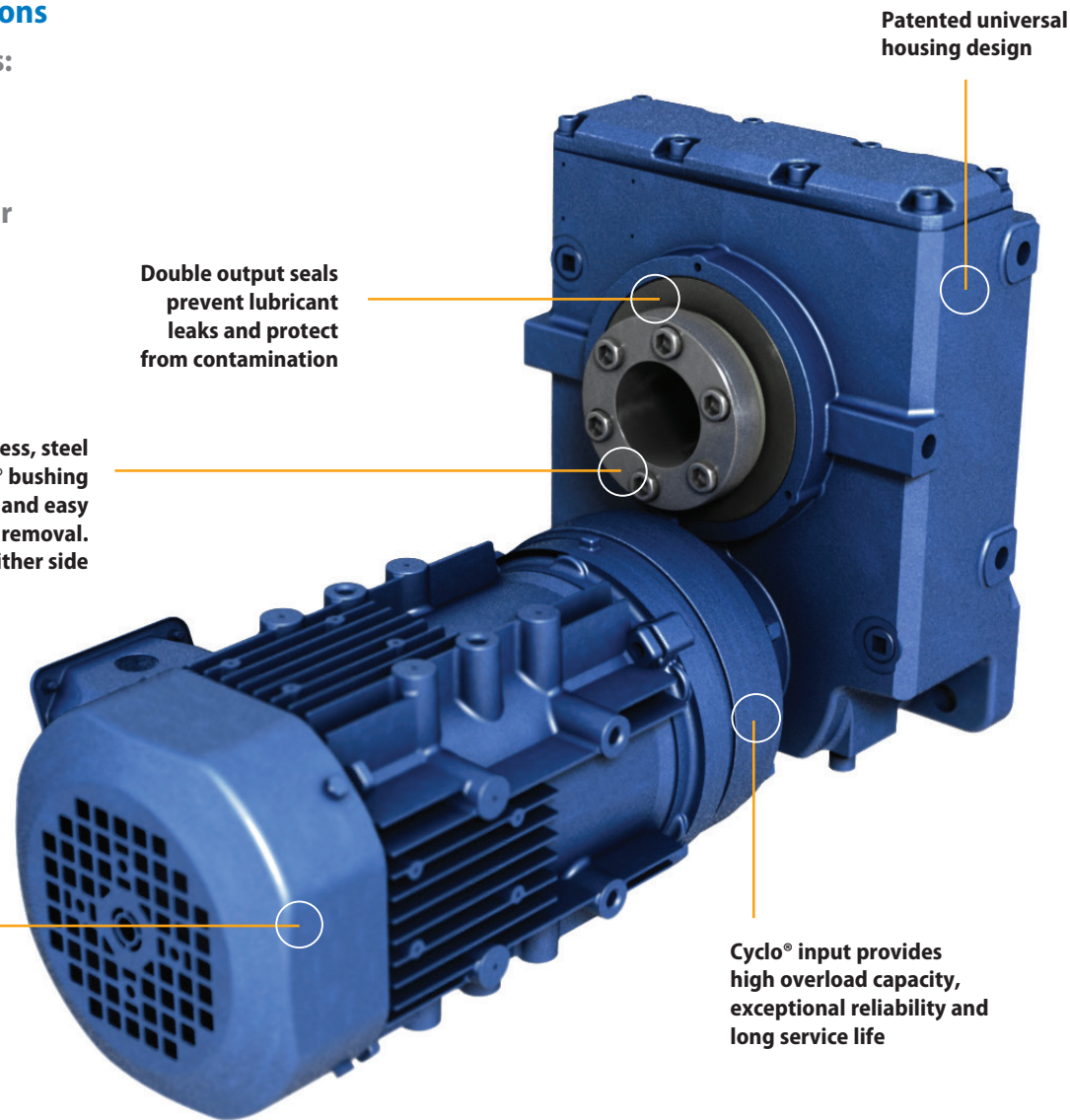

Patented universal housing design

Product Description

Sumitomo's Cyclo® Helical Buddybox (Cyclo® HBB) speed reducers and gearmotors provide **innovative shaft mounted drive solutions for demanding services**. The Cyclo® HBB combines the quiet, efficient and reliable performance of the Cyclo® technology input with the **rugged helical gear output**. The **modular design** provides a compact, efficient product and the most flexible range of output speed and torque combinations available. Sumitomo's patented Taper Grip® bushing system enhances the Cyclo® HBB value by offering a simple shaft-mounting device that provides **self-aligning, backlash-free torque transmission** to the driven shaft. The Cyclo® HBB design is flexible and easily adapts to CEMA Screw Conveyor Drive applications with a modular conversion kit.

Features & Benefits

- **Cycloidal speed reduction technology**
  - ~ Quiet, efficient and reliable operation with high torque density and compact size
- **Modular design**
  - ~ Interchangeable cast iron housings in foot, flanged or face mount configurations
- **Double output seals**
  - ~ Virtually leak-free operation and optimal protection from lubrication contamination
- **Taper Grip® Bushing**
  - ~ Simple, steel, keyless shaft mounting system resists fretting and eases unit installation and removal from driven shaft
- **CEMA Screw Conveyor Drive option**
  - ~ Quick and simple conversion for Cyclo® HBB units to fit CEMA standard dimensions

Specifications

<b>Ratios:</b>	11:1 up to 26,000:1 and greater
<b>Torque Capacity:</b>	Up to 75,800 in. lbs.
<b>HP:</b>	1/8 to 40
<b>Mounting:</b>	Hollow Shaft, Flange, Face
<b>Options:</b>	Integral Motor, C-Face, Quill
<b>Motor Standards:</b>	NEMA, IEC, JIS, UL, CSA, CE

► Keyless, steel Taper-Grip® bushing makes mounting of hollow shaft units easy and economical

The Sumitomo **Taper-Grip®** bushing is a keyless, torque transmission device integrated into the shaft mounted, offset parallel Cyclo® HBB reducer and gearmotor product lines.

The **unique, patented design** has a number of benefits :

- Easy mounting and removal of the unit to and from the driven shaft
- Standard bore sizes require no shaft preparation such as a keyway, undercut, or keeper plate
- Backlash free torque transmission
- Works with standard shafting, no special tolerances required
- Automatic shaft center alignment
- Resistant to fretting corrosion
- Multiple stock bore sizes for quick delivery.

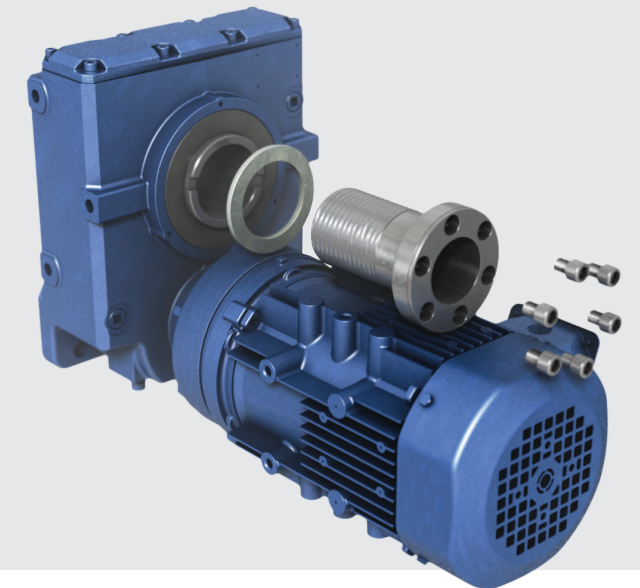

Cyclo® Quality and Reliability, Shaft Mount Design

► High performance steel gearing components deliver up to 95% efficiency



► Applications

- Material Handling
- Conveyors
- Baggage Handling
- Shredders
- Belt Filter Press
- Mixer/Blender
- Rolling Mill Table
- Screw Conveyors
- Elevators
- Hoist Drives
- Climber Screens
- Food Processing



# Enhanced Performance (EP) Motors FAQs

## What efficiency level are these Enhanced Performance (EP) motors?

The EP motor (applies to 1HP and above) is a Premium efficiency class, or International Efficiency 3 (IE3) design. Our integral fractional (less than 1HP) motors are not EP and are classified as standard efficiency IE1 motors.

## What standards do these motors meet?

All Sumitomo motors are compliant with the Energy Policy and Conservation Act (EPAAct), as recently amended by the Department of Energy with a new ruling.

EP Sumitomo motors met the efficiency levels promoted by the Consortium for Energy Efficiency (CEE) and meet the Canadian efficiency levels specified by NRCan.

The IE3 efficiency ratings conform to both the IEC Standard 60034-30:2009 and eco-design directive 2005/32/EC.

## Will Sumitomo motors work with VFDs?

All current EP motors feature corona resistant magnet wire that extends the life of the insulation and enables the motors to resist the voltage spikes common with IGBT variable frequency drives.

## What agency listings apply?

All EP motors in this product line are UL recognized, CSA certified and CE marked.

## Can the motor be nameplated to operate at 50 hertz?

The motor can be nameplated and will operate at 50 hertz, but depending on the export destination, it may not meet that country's energy efficiency requirements. For areas requiring IE3 performance at 50 hertz, like Asia and Europe, other 50 hertz specific versions can be provided. Conformance with energy efficiency requirements in destination country is the responsibility of the customer.

## Is the selection procedure the same as previous gearmotors?

Similar, the difference is restricted to applications with a large number of across the line starts and stops. Because the EP motors have more inertia and higher inrush current than previous integral motors, a supplemental service factor is applied to these applications using EP motors. The selection procedure for fractional HP units is unchanged.

## Are the brakes the same?

The brakes are the same direct acting, fast response types used previously. For motors 1 HP and above they are a new larger model that has been redesigned to match the new motor profiles. Because the EP motor inertia is significantly higher, it may be necessary to adjust external trigger points or limit switches. Since the brake assembly shapes are different, old and new kits are not interchangeable.

## What is the standard insulation system?

The motors continue with the Class F system, which limits the temperature rise to a Class B rise, where it bounds the allowable temperature rise to 80°C. It utilizes an insulation system capable of handling a 105°C rise to significantly extend insulation life.

## Are EP motors interchangeable with old AF-motors?

The new EP motors without brake have the same 10:1 constant torque speed range as the AF-motor. Motors are dimensionally and performance-wise different so VFD re-programming may be required. For EP brakemotor with use on VFDs, the applicable speed range may be limited. Please consult the factory for options for EP brakemotors.

## Will old motors continue to be available?

For motor powers 1 HP and above, EP motors have replaced the standard efficiency motors. (does not apply to fractional HP). 1HP+ Older motors do not meet the federally mandated efficiency requirements that went into effect on June 1, 2016. Non-compliant motors cannot be manufactured or imported into the United States.

## Should I be concerned if I am replacing an older motor with the new EP motor?

For most applications, the use of the new EP motor will result in a more efficient, cooler-running and energy-saving motor. However, for applications with certain performance constraints, you may need to review the impact of the following:

- larger dimension and weight
- larger moment of inertia
- higher starting current and torque.

If taking an old standard efficiency motor off a gearmotor and replacing it with the same HP new EP motor, the EP motor will bolt to the old gearmotor. The motor flange diameters, pilot diameters, bolt patterns and shaft diameters all match. Motor body dimensions and weight will change.

# Standard Specifications

	Standard Specifications	Standard Specifications with Built-In Brake	
<b>3 Phase Integral Motor Fractional HP Motor</b>	Capacity Range	1/8 through 3/4 HP (4 pole)	1/8 through 3/4 HP (4 pole)
	Power Supply	Motor Power: 230 / 460V, 60 Hz, 3 Phase 575V, 60 Hz, 3 Phase	Motor Power: 230 / 460V, 60 Hz, 3 Phase 575V, 60 Hz, 3 Phase Brake Power: 230 / 460V, 60 Hz, 1 Phase 575V, 60 Hz, 1 Phase
	Motor Standard	NEMA	NEMA
	Efficiency	Standard Efficiency (IE1)	Standard Efficiency (IE1)
	Protection	IP55	IP55
	Certification	CE Mark, UL Recognition, CSA Approval	CE Mark, UL Recognition, CSA Approval
	Conduit Box	Diecast Aluminum, NPT Conduit Thread	Diecast Aluminum, NPT Conduit Thread
Inverter Operation	2:1 Constant Torque Speed Range 10:1 Optional (Select AF Motor) Insulation Meets NEMA MG1, Part 31	2:1 Constant Torque Speed Range 10:1 Optional (Select AF Motor) Insulation Meets NEMA MG1, Part 31	
<b>3 Phase Integral EP,NA Motor</b>	Capacity Range	1 through 40 HP (4 pole)	1 through 40 HP (4 pole)
	Power Supply	Motor Power: 230 / 460V, 60 Hz, 3 Phase 575V, 60 Hz, 3 Phase	Motor Power: 230 / 460V, 60 Hz, 3 Phase 575V, 60 Hz, 3 Phase Brake Power: 230 / 460V, 60 Hz, 1 Phase 575V, 60 Hz, 1 Phase
	Motor Standard	NEMA	NEMA
	Efficiency	Premium Efficiency (IE3)	Premium Efficiency (IE3)
	Protection	IP55	IP55
	Certification	CE Mark, UL Recognition, CSA Approval	CE Mark, UL Recognition, CSA Approval
	Conduit Box	Diecast Aluminum, NPT Conduit Thread	Diecast Aluminum, NPT Conduit Thread
Inverter Operation	10:1 Constant Torque Speed Range Insulation Meets NEMA MG1, Part 31	Constant Torque Speed Range: (4:1 or better) 10:1 Optional (Select SSC YA01 Motor - UL and CE Only) Insulation Meets NEMA MG1, Part 31	
<b>3 Phase Integral IE3 CE Motor</b>	Capacity Range	0.75 through 30 kW (4 pole)	0.75 through 30 kW (4 pole)
	Power Supply	Motor Power (0.75 through 4.0 kW) 230 / 400V, 50 Hz, 3 Phase (5.5 through 30 kW) 400V, 50 Hz, 3 Phase	Motor Power (0.75 through 4.0 kW) 230 / 400V, 50 Hz, 3 Phase (5.5 through 30 kW) 400V, 50 Hz, 3 Phase Brake Power (0.75 through 4.0 kW) 220 - 240V, 50 Hz, 1 Phase (5.5 through 30 kW) 380 - 415V, 50 Hz, 1 Phase
	Motor Standard	IEC	IEC
	Efficiency	IE3	IE3
	Protection	IP55	IP44
	Certification	CE Mark	CE Mark
	Conduit Box	Diecast Aluminum, Metric Conduit Thread	Diecast Aluminum, Metric Conduit Thread
Inverter Operation	5:1 Constant Torque Speed Range Spike Resistant Inverter Grade Wire Insulation	3:1 Constant Torque Speed Range Spike Resistant Inverter Grade Wire Insulation	
<b>3 Phase Integral Motor - Common</b>	Enclosure	Totally Enclosed Fan Cooled (TEFC) 1/8 HP - Totally Enclosed Non-Ventilated (TENV)	Totally Enclosed Fan Cooled (TEFC) 1/8 HP - Totally Enclosed Non-Ventilated (TENV)
	Motor Type	Asynchronous Induction Motor, Squirrel Cage Rotor	Asynchronous Induction Motor, Squirrel Cage Rotor
	Frame Material	Diecast Aluminum	Diecast Aluminum
	Bearings	Double Shielded, Deep Groove, Ball Bearing, CM Clearance	Double Shielded, Deep Groove, Ball Bearing, CM Clearance
	Insulation	Class F	Class F - Motor and Brake
	Time Rating	Continuous	Continuous
<b>HBB® Reducer</b>	Reduction	Combination of Cyclo or Planetary input and helical gear output.	
	Lubrication	Cyclo portion is grease or oil, planetary and helical portions are oil lubricated.	
	Seals	Nitrile material, dual lipped, tandem output seals.	
	Material	Rugged cast iron housings in all sizes.	
	Paint Color	Blue, Munsell color number 6.5PB 3.6/8.2	
<b>Ambient Conditions</b>	Bearings	Output tapered roller bearings optional.	
	Installation Location	Indoor or outdoor with open cover.	
	Ambient Temperature	14° ~ 104° F (-10° ~ 40° C)	
	Ambient Humidity	Under 85%	
	Elevation	Under 3300 feet (1000 meters)	
Atmosphere	Well ventilated location, free of corrosive gases, explosive gases, vapors, and dust		

# Mounting Positions

Please see the Appendix (Section 5) for additional mounting configurations.  
 1. Mounting positions are shown with standard (Taper Grip Bushing) output option.  
 2. The plane of reference represents the location of customer's equipment.

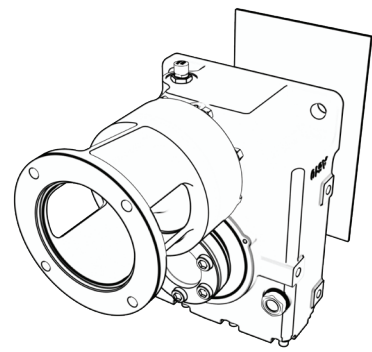

Y1

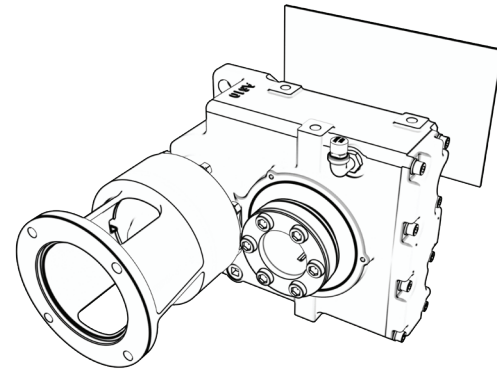

Y2

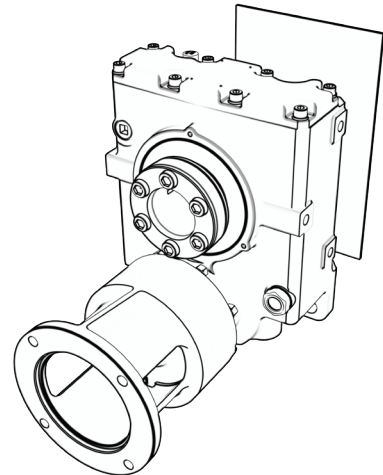

Y3

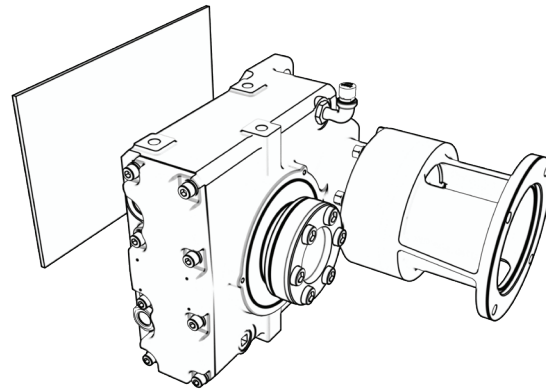

Y4

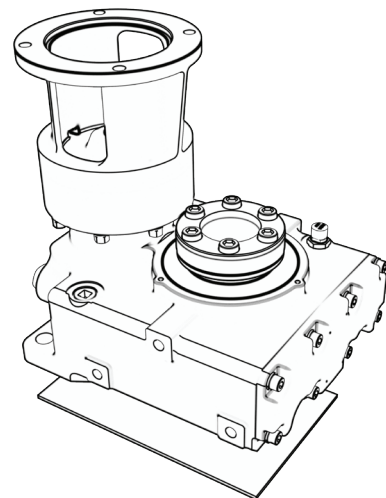

Y5

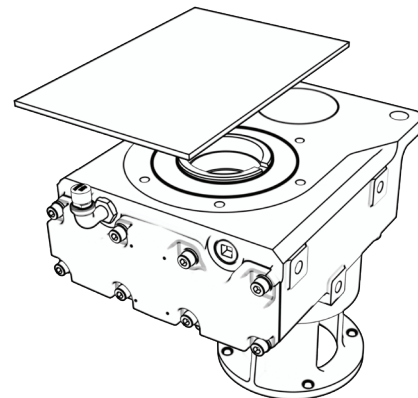

Y6

# Additional Mounting Configurations

## Flange Mounting Positions

Fig. 5.18 Hollow Shaft, Flange Mount

EHY□ - □ - F1	EHY□ - □ - F2	EHY□ - □ - F3
<p>Ceiling</p> <p>Floor</p>	<p>Ceiling</p> <p>Floor</p>	<p>Ceiling</p> <p>Floor</p>
EHY□ - □ - F4	EVY□ - □ - F5	EVY□ - □ - F6
<p>Ceiling</p> <p>Floor</p>	<p>Ceiling</p> <p>Floor</p>	<p>Ceiling</p> <p>Floor</p>

Notes: [1] □ indicates various nomenclature designations for input connection, frame size, ratio, etc. Please see pages 2.4 and 3.4 for complete reducer and gearmotor nomenclature.  
 [2] ◇ = Oil Fill Location; ◊ = Oil Level Location; ◆ = Oil Drain Location.  
 [3] For positions F5 and F6, the Cyclo® portion is grease-lubricated; oil fill and drain ports are unnecessary.  
 [4] For Cyclo® HBB sizes Z6090 - C6145 position F5 has two drain ports.

---

Page intentionally left blank.



# 2

# Speed Reducers

---

## Hollow Shaft Type

Cyclo® HBB

How to  
Select



# How to select a Speed Reducer

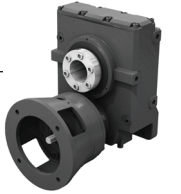

## Step 1: Collect data about your application

Before starting you need to know the:

- Application (e.g. Conveyor, Mixer, etc.)
- Hours of Operation per day
- Motor Power (HP or kW) and Speed (RPM)
- Desired Output Speed
- Mounting Position and Style
- Overhung or Thrust Loads
- Bore Dimensions (inch or metric)
- Ambient Conditions

### Mounting Positions

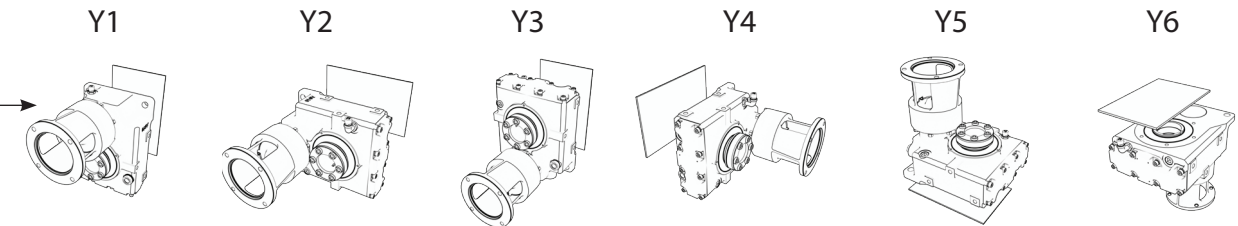

## Step 2: Choose a Mounting Position

Find the correct Mounting Position from the Mounting Positions Table on the right.

## Step 3: Select a Frame Size

**3A:** Find the Load Classification of your application in the AGMA Load Classification Table on page 2.6.

**3B:** Find the recommended Service Factor using the Recommended Reducer Service Factor Table on the right.

**3C:** Determine the Selection Horsepower (HP or kW) by multiplying the Motor Power (HP or kW) by the Service Factor.

**3D:** Select a Frame size from the Reducer Selection Tables on pages 2.8–2.13 by matching both the Selection Horsepower and Desired Output Speed (RPMs) to a frame size model number. **Note:** For Mounting Positions Y1, Y2, Y3, Y4 see pages 2.8–2.9. For Mounting Positions Y5 and Y6 see pages 2.10–2.11). For all Double Reduction Mounting Positions see pages 2.12–2.13.

### Recommended Reducer Service Factors

	AGMA Load Classifications		
	Uniform (U)	Moderate Shock (M)	Heavy Shock (H)
1/2 hr. per day (Occasional)	0.50 <sup>[1]</sup>	0.80 <sup>[1]</sup>	1.25
3 hrs. per day (Intermittent)	0.80	1.00	1.50
Up to 10 hrs. per day	1.00	1.25	1.75
24 hrs. per day	1.20	1.50	2.00

**Note:** [1] Maximum momentary or starting load must not exceed 300% of gear reducer rating (rating meaning service factor of 1.0). Time specified for occasional and intermittent service refers to total operating time per day.

### Determine Selection Horsepower (HP)

$$\text{Motor HP} \times \text{Service Factor} = \text{Selection HP}$$

Example: 10 Motor HP X 1.25 Service Factor = 12.5 Selection HP

## Step 4: Verify Dimensions

Use the Dimensions information on pages 2.14–2.20 to verify that the selected Frame Size is appropriate.

## Step 5: Choose an Output Connection Method

Select keyed hollow bore or Taper-Grip® Bushing, and the associated bore size. For Taper-Grip® Bushing select a Bore Size from the Stock Bushing Bore Size Table.

## Step 6: Choose Options

Please refer to Options section 4.1. For additional available options refer to our online Product Configurator at [www.sumitomodrive.com/configurator](http://www.sumitomodrive.com/configurator)

## Step 7: Configure a Model Number

Go to page 2.4 to configure a model number. **Note:** You will use the information you gather from the procedure on this page to Configure a Model Number.

STOCK TAPER GRIP® BUSHING BORES

Size	Inch Sizes	Metric Sizes	Min. Bore*
Z	1 <sup>3</sup> / <sub>16</sub> , 1 <sup>7</sup> / <sub>16</sub>	30, 40	1 <sup>3</sup> / <sub>16</sub>
A	1 <sup>15</sup> / <sub>16</sub> , 2 <sup>3</sup> / <sub>16</sub>	50, 55	1 <sup>11</sup> / <sub>16</sub>
B	2 <sup>3</sup> / <sub>16</sub> , 2 <sup>7</sup> / <sub>16</sub>	60, 65	1 <sup>15</sup> / <sub>16</sub>
C	2 <sup>7</sup> / <sub>16</sub> , 2 <sup>15</sup> / <sub>16</sub>	65, 75	2 <sup>3</sup> / <sub>16</sub>
D	2 <sup>15</sup> / <sub>16</sub> , 3 <sup>7</sup> / <sub>16</sub>	75, 85	2 <sup>7</sup> / <sub>16</sub>
E	3 <sup>7</sup> / <sub>16</sub> , 3 <sup>15</sup> / <sub>16</sub>	90, 100	2 <sup>15</sup> / <sub>16</sub>

### Select a Frame Size

1 Match your OUTPUT RPM (or RATIO)...

Output RPM	20.0	17.2	14.3	11.6	9.80	8.47	7.04	5.75	4.20	Frame Size
Ratio	88	102	123	151	179	207	249	305	417	
Input Power HP (kW)	0.899 (0.671)	0.838 (0.625)	0.821 (0.602)	0.584 (0.435)	0.444 (0.332)	0.414 (0.309)	0.337 (0.252)	0.283 (0.211)	0.168 (0.125)	Z6090
Output Torque in-lbs (N-m)	2610 (295)	2830 (319)	3330 (377)	2920 (330)	2640 (298)	2840 (321)	2790 (315)	2870 (324)	2320 (262)	
Input Power HP (kW)	1.16 (0.866)	1.05 (0.784)	0.960 (0.716)	0.781 (0.583)	0.566 (0.422)	0.500 (0.373)	0.404 (0.301)	0.386 (0.288)	0.202 (0.151)	Z6095
Output Torque in-lbs (N-m)	3380 (381)	3540 (400)	3980 (441)	3900 (441)	3350 (376)	3430 (390)	3340 (377)	3900 (441)	2800 (316)	
Input Power HP (kW)	1.70 (1.27)	1.62 (1.21)	1.31 (0.975)	0.584 (0.436)	0.580 (0.433)	0.282 (0.210)	0.584 (0.436)	0.580 (0.433)	0.282 (0.210)	A6100
Output Torque in-lbs (N-m)	4950 (559)	5470 (618)	5330 (601)	4820 (545)	5870 (663)	3900 (440)	4820 (545)	5870 (663)	3900 (440)	
Input Power HP (kW)	2.24 (1.67)	2.13 (1.59)	1.61 (1.20)	0.752 (0.561)	0.757 (0.565)	0.383 (0.286)	0.752 (0.561)	0.757 (0.565)	0.383 (0.286)	A6105
Output Torque in-lbs (N-m)	6510 (735)	7190 (812)	6540 (738)	6210 (701)	7660 (866)	5300 (599)	6210 (701)	7660 (866)	5300 (599)	

2 ...to your SELECTION HP...

3 ...to find your FRAME SIZE

If Overhung Load is present, it must be checked against the capacity of the selection.



For special circumstances affecting Frame Size selection such as:

- Overhung Load
- Shock Loading

Consult Appendix, pages 5.7.

# Configure a Model Number

# Nomenclature

### Output Shaft Orientation

Type	Prefix
Horizontal	H
Vertical	V

### Mounting Style

Type	Prefix
Flange (Keyed Hollow Bore) pg. 4.3	F
Shaft Mount (Hollow Shaft)	Y

### Input Connection

Input Connection	Prefix
C-Face Adapter with jaw coupling	J
Quill Hollow Input	X
Free Input Shaft	

### Modification

	Prefix
Special	S
Standard	

Required to be added at end of model number when ordering:

- Motor frame size for input adapter or Quill Hollow Input.
- Taper Grip Bushing or Keyed Hollow Bore diameter (refer to pages 4.2 to 4.3 for diameters)
- Optional conduit box positions must be specified, or standard is provided, refer to page 5.13
- Optional Industry Package, refer to page 4.6
- Specify type for nonstandard torque arm or no torque arm

### Frame Size

Single Reduction		
Z6090	B6120	D6160
Z6095	B6125	D6165
A6100	C6140	E6170
A6105	C6145	E6175
Double Reduction		
Z609DA	C614DB	D616DC
A610DA	C614DC	E617DA
B612DA	D616DA	E617DB
B612DB	D616DB	E617DC
C614DA		

### Shaft Specifications

Input Shaft	Hollow Output Shaft	Suffix
mm	Key (mm)	
Inch	Key (Inch)	K
mm	Taper-Grip®	M
Inch	Taper-Grip®	Y

### Reducer Specification

Type	Suffix
Standard	
High Capacity Bearing (required for screw conveyor)	R1

### Mounting Positions (Please see page 1.9 for additional mounting positions.)

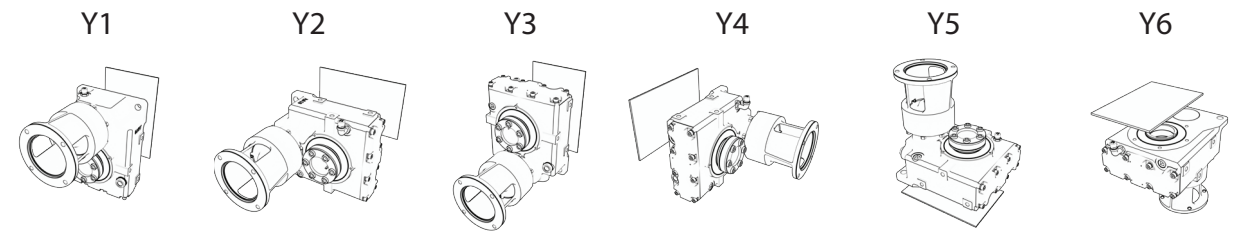

### Nominal Total Ratio

Single Reduction Input		Double Reduction Input	
Input Ratio	Total Ratio	Input Ratio	Total Ratio
3	11	104	364
5	18	121	424
6	21	143	501
8	28	165	578
11	39	195	683
13	46	231	809
15	53	273	956
17	60	319	1117
21	74	377	1320
25	88	473	1656
29	102	559	1957
35	123	649	2272
43	151	731	2559
51	179	841	2944
59	207	1003	3511
71	249	1247	4365
87	305	1479	5177
119	417	1849	6472
		2065	7228
		2537	8880
		3045	10568
		3481	12184
		4437	15530
		5133	17966
		6177	21620
		7569	26492

### Nomenclature Example:

**EHYJ - Z6090Y - Y1 - 21**

- E** – Cyclo® Helical Buddybox
- H** – Horizontal Output
- Y** – Shaft Mount (Hollow Shaft)
- J** – C-Face Input
- Z6090** – Frame Size
- Y** – Inch Shaft Specification
- Y1** – Mounting Position
- 21** – Ratio

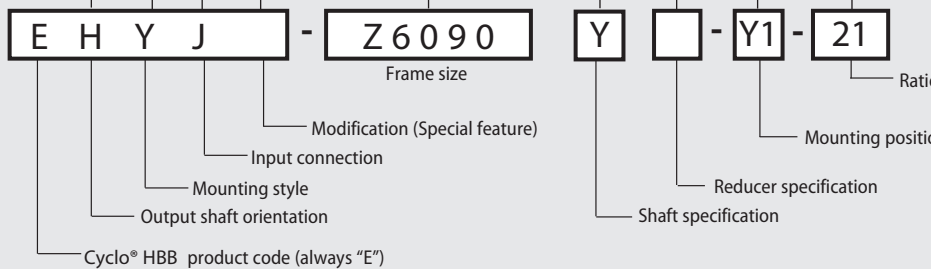

Cyclo® HBB  
Nomenclature

Cyclo® HBB  
Nomenclature

# AGMA Load Classifications

This page intentionally left blank.

TYPE OF APPLICATION	TYPE OF LOAD
Agitators	
Pure liquids	U
Liquids and solids	M
Variable-density liquids	M
Blowers	
Centrifugal	U
Lobe	M
Vane	U
Brewing and Distilling	
Bottling machinery	U
Brew kettles, cont. duty	U
Cookers, cont. duty	U
Mash tubs, cont. duty	U
Scale hopper, frequent starts	M
Can Filling Machines	U
Cane Knives	M
Car Dumpers	H
Car Pullers	M
Clarifiers	U
Classifiers	M
Clay Working Machinery	
Brick press	H
Briquette machine	H
Clay working machinery	M
Pug mill	M
Compressors	
Centrifugal	U
Lobe	M
Reciprocating, multi-cylinder	M
Reciprocating, single-cylinder	H
Conveyors — Uniformly Loaded or Fed	
Apron	U
Assembly	U
Belt	U
Bucket	U
Chain	U
Flight	U
Oven	U
Screw	U
Conveyors — Heavy Duty, Not Uniformly Fed	
Apron	M
Assembly	M
Belt	M
Bucket	M
Chain	M
Flight	M
Live roll oven	M
Reciprocating	H
Screw	M
Shaker	H
Cranes (Except for Dry Dock Cranes)	
Main hoists	U
Bridge travel	S
Trolley travel	S
Crusher	
Ore H	
Stone	H
Sugar	M
Dredges	
Cable reels	M
Conveyors	M
Cutter head drives	H
Jig drives	H
Maneuvering winches	M
Pumps	M
Screen drive	H
Stackers	M
Utility winches	M
Dry Dock Cranes	S
Elevators	
Bucket, uniform load	U
Bucket, heavy load	M
Bucket, cont.	U
Centrifugal discharge	U
Escalators	U
Freight	M
Gravity discharge	U
Man lifts	S
Passenger	S
Extruders (Plastics)	
Blow molders	M
Coating	U
Film	U
Pipe	U
Pre-plasticizers	M
Rods	U
Sheet	U
Tubing	U
Fans	
Centrifugal	U
Cooling towers	S
Forced draft	S
Induced draft	M
Large (mine, etc.)	M

TYPE OF APPLICATION	TYPE OF LOAD
Large (industrial)	M
Light (small diameter)	U
Feeders	
Apron	M
Belt	M
Disc	U
Reciprocating	H
Screw	M
Food Industry	
Beet slicer	M
Cereal cooker	U
Dough mixer	M
Meat grinders	M
Generators (Not Welding)	U
Hammer Mills	H
Hoists	
Heavy duty	H
Medium duty	M
Skip	M
Laundry Washers — Reversing	M
Laundry Tumblers	M
Line Shaft	
Drive processing equipment	M
Light	M
Other line shafts	U
Lumber Industry	
Barkers — hydraulic and mechanical	S
Burner conveyor	M
Chain Saw and Drag Saw	H
Chain transfer	H
Craneway transfer	H
De-barking drum	S
Edger feed	H
Gang feed	M
Geen chain	M
Live rolls	H
Log haul-lockline	H
Log turning device	H
Main log conveyor	H
Off bearing rolls	M
Planer feed chains	M
Planer floor chains	M
Planer tilting hoist	M
Re-saw merry-go-round conveyor	M
Roll cases	H
Slab conveyor	H
Small waste-conveyor-belt	U
Small waste-conveyor-chain	M
Sorting table	M
Tipple hoist conveyor	M
Tipple hoist drive	M
Transfer conveyors	M
Transfer rolls	M
Tray drive	M
Trimmer feed	M
Waste conveyor	M
Machine Tools	
Bending roll	M
Notching press, belt driven	S
Plate planer	H
Punch press, gear driven	H
Tapping machine	H
Other machine tools	
Main drives	M
Auxiliary drives	U
Metal Mills	
Draw bench carriage and main drive	M
Forming machines	H
Pinch, dryer and scrubber rolls, reversing	S
Slitters	M
Table conveyors, nonreversing	
Group drives	M
Individual drives	H
Table conveyors, reversing	S
Wire drawing and flattening machine	M
Wire winding machine	M
Mills, Rotary Type	
Ball M	
Cement kilns	M
Dryers and coolers	M
Kilns	M
Pebble	M
Rod, plain and wedge bar	M
Tumbling barrels	H
Mixers	
Concrete mixers, cont.	M
Concrete mixers, intermittent	M
Constant density	U
Variable density	M
Oil Industry	
Chillers	M
Oil well pumps	S
Paraffin filter press	M
Rotary kilns	M

TYPE OF APPLICATION	TYPE OF LOAD
Paper Mills	
Agitators (mixers)	M
Barker, hydraulic	S
Barker, mechanical	S
Barking drum	S
Beater and pulper	M
Bleacher	U
Calenders	M
Calenders, super	H
Converting machine (except cutters, platers)	M
Conveyors	U
Couch	M
Cutters, platers	H
Cylinders	M
Dryers	M
Felt stretcher	M
Felt whipper	H
Jordans	H
Log haul	H
Presses	U
Pulp machine reel	M
Stock chest	M
Suction roll	U
Washers and thickeners	M
Winders	U
Printing Presses	S
Pullers, Barge Haul	H
Pumps	
Centrifugal	U
Proportioning	M
Reciprocating	
Single acting, 3 or more cylinders	M
Double acting, 2 or more cylinders	M
Rotary-gear type	U
Rubber and Plastics Industries	
Crackers	H
Laboratory equipment	M
Mixing mills	H
Refiners	M
Rubber calenders	M
Rubber mill (2 on line)	M
Rubber mill (3 on line)	U
Sheeter	M
Tire building machines	S
Tire and tube press openers	S
Tubers and strainers	M
Warming mills	M
Sand Muller	M
Screens	
Air washing	U
Rotary, stone or gravel	M
Traveling water intake	U
Sewage Disposal Equipment	
Bar screens	U
Chemical fenders	U
Collectors, circuline or straightline	U
Dewatering screens	M
Grit collectors	U
Scum breakers	M
Slow or rapid mixers	M
Sludge collectors	U
Thickeners	M
Vacuum filters	M
Slab Pushers	M
Steering Gear	S
Stokers	U
Sugar Industry	
Cane knives	M
Crushers	M
Mills	H
Textile Industry	
Batchers	M
Calenders	M
Cards	M
Dry cans	M
Dryers	M
Dyeing machinery	M
Knitting machines	S
Looms	M
Mangles	M
Nappers	M
Pads	M
Range drives	S
Slashers	M
Soapers	M
Spinners	M
Tenter frames	M
Washers	M
Winders	M
Windlass	S

U = Uniform Load	H = Heavy Shock
M = Moderate Shock	S = Contact Sumitomo

Cydo® HBB  
AGMA  
Tables

Cydo® HBB















# Quill Hollow Input Dimensions

## Double Reduction

### EHY(X)-Z6090DAY~E6175DCY

Cydo® HBB  
Dimensions

Model	NEMA C-Face		ØAJ	ØAK	ØBD	BB	BF	BR(R)	C	CE	XU	XU Tol.	XV	Keyway	Wt. lb (kg)	
Z609DA	56C	607	5.87 (149.1)	4.50 (114.3)	6.69 (170.0)				10.61 (269.5)	11.63 (295.5)	0.63 (15.9)	0.0014 / 0.0007 (0.034 / 0.016)	1.1 (28.0)	3/16 x 3/32 (4.762 x 2.381)	70	
A610DA		607							11.76 (298.8)	12.78 (324.7)					95	
B612DA		607							13.25 (336.6)	14.27 (362.5)					163	
B612DB		609							14.06 (357.2)	15.09 (383.3)					170	
	14.47 (367.6)		0.88 (22.3)	0.0016 / 0.0008 (0.041 / 0.020)	1.57 (39.9)											
C614DA	56C	607	3.75 (95.3)	3.00 (76.2)	4.33 (110.0)				15.79 (401.1)	16.81 (427.0)	0.63 (15.9)	0.0014 / 0.0007 (0.034 / 0.016)	1.1 (28.0)	253		
C614DB		609	16.5 (419.1)	17.53 (445.3)	1.18 (30.0)											
	16.91 (429.6)		0.88 (22.3)	0.0016 / 0.0008 (0.041 / 0.020)	1.57 (39.9)											
C614DC	56C	610	5.87 (149.1)	4.50 (114.3)	6.69 (170.0)							16.82 (427.3)	17.88 (454.2)		0.63 (15.9)	0.0014 / 0.0007 (0.034 / 0.016)
	143~145TC					17.29 (439.2)	0.88 (22.3)	0.0016 / 0.0008 (0.041 / 0.020)				1.65 (42.0)				
	182~184TC					18.23 (463.1)	19.04 (483.7)	1.13 (28.6)				0.0016 / 0.0008 (0.041 / 0.020)	1.89 (48.1)	1/4 x 1/8 (6.35 x 3.175)	272	
D616DA	56C	609	5.87 (149.1)	4.50 (114.3)	6.69 (170.0)				18.64 (473.5)	19.67 (499.7)	0.63 (15.9)	0.0014 / 0.0007 (0.034 / 0.016)	1.18 (30.0)	466		
	143~145TC								19.05 (483.9)	0.88 (22.3)					0.0016 / 0.0008 (0.041 / 0.020)	1.57 (39.9)
D616DB	56C	610	5.87 (149.1)	4.50 (114.3)	6.69 (170.0)				18.96 (481.6)	20.02 (508.6)	0.63 (15.9)	0.0014 / 0.0007 (0.034 / 0.016)	1.18 (30.0)	471		
	143~145TC								19.43 (493.6)	0.88 (22.3)					0.0016 / 0.0008 (0.041 / 0.020)	1.65 (42.0)
	182~184TC								20.37 (517.4)	21.18 (538.0)	1.13 (28.6)	0.0016 / 0.0008 (0.041 / 0.020)	1.89 (48.1)		1/4 x 1/8 (6.35 x 3.175)	479
D616DC	56C	612	5.87 (149.1)	4.50 (114.3)	6.69 (170.0)				19.85 (504.2)	20.91 (531.2)	0.63 (15.9)	0.0014 / 0.0007 (0.034 / 0.016)	1.18 (30.0)	489		
	143~145TC								20.04 (509.1)	0.88 (22.3)					0.0016 / 0.0008 (0.041 / 0.020)	1.5 (38.1)
	182~184TC								21.14 (537.0)	21.83 (554.5)	1.13 (28.6)	0.0014 / 0.0007 (0.034 / 0.016)	1.89 (48.1)		1/4 x 1/8 (6.35 x 3.175)	492
	213~215TC								21.26 (540.1)	1.38 (35.0)	0.002 / 0.001 (0.050 / 0.025)	2.64 (67.1)	5/16 x 5/32		492	
E617DA	56C	609	5.87 (149.1)	4.50 (114.3)	6.69 (170.0)				20.02 (508.6)	21.05 (534.7)	0.63 (15.9)	0.0014 / 0.0007 (0.034 / 0.016)	1.18 (30.0)	623		
	143~145TC								20.43 (519.0)	0.88 (22.3)					0.0016 / 0.0008 (0.041 / 0.020)	1.57 (39.9)
E617DB	56C	610	5.87 (149.1)	4.50 (114.3)	6.69 (170.0)				20.34 (516.7)	21.40 (543.6)	0.63 (15.9)	0.0014 / 0.0007 (0.034 / 0.016)	1.18 (30.0)	628		
	143~145TC								20.81 (528.6)	0.88 (22.3)					0.0016 / 0.0008 (0.041 / 0.020)	1.65 (42.0)
	182~184TC								21.75 (552.5)	22.56 (573.1)	1.13 (28.6)	0.0016 / 0.0008 (0.041 / 0.020)	1.89 (48.1)		1/4 x 1/8 (6.35 x 3.175)	636
E617DC	56C	612	5.87 (149.1)	4.50 (114.3)	6.69 (170.0)				21.31 (541.3)	22.37 (568.2)	0.63 (15.9)	0.0014 / 0.0007 (0.034 / 0.016)	1.18 (30.0)	641		
	143~145TC								21.5 (546.1)	0.88 (22.3)					0.0016 / 0.0008 (0.041 / 0.020)	1.5 (38.1)
	182~184TC								22.6 (574.1)	23.29 (591.6)	1.13 (28.6)	0.0014 / 0.0007 (0.034 / 0.016)	1.89 (48.1)		1/4 x 1/8 (6.35 x 3.175)	644
	213~215TC								22.72 (577.1)	1.38 (35.0)	0.002 / 0.001 (0.050 / 0.025)	2.64 (67.1)	5/16 x 5/32			

# 3

## How to Select

---

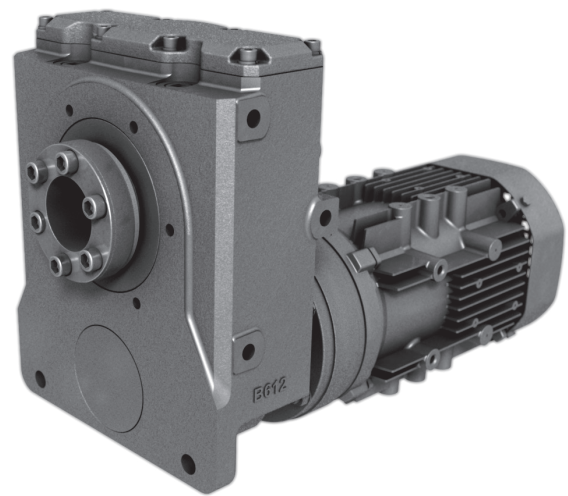

Cyclo® HBB

How to  
Select

# How to Select a Gearmotor

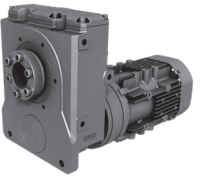

## Step 1: Collect data about your application

Before starting you need to know the:

- Application (e.g. Conveyor, Mixer, etc.)
- Hours of Operation per day
- Motor Horsepower (HP) and Speed (RPM)
- Desired Output Speed
- Mounting Position and Style
- Overhung or Thrust Loads
- Bore Dimensions, inch or metric
- Electrical Specifications

## Step 2: Choose a Mounting Position

Find the correct Mounting Position from the Mounting Positions Table on the right.

Mounting Positions (Please see the Appendix, Section 5, for additional mounting positions.)

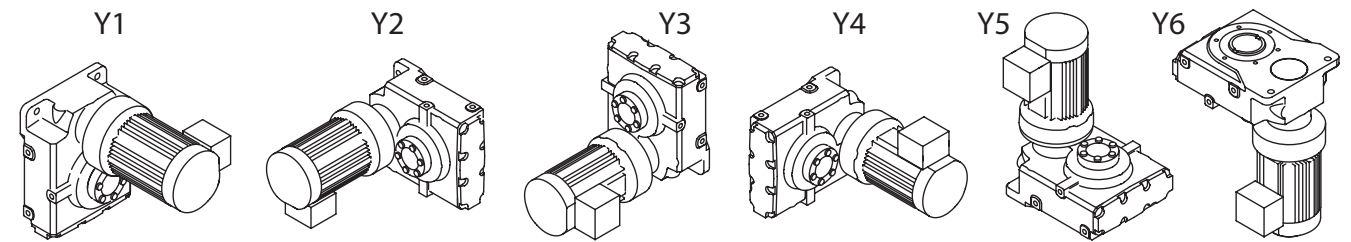

## Step 3: Select a Frame Size

3A: Find the Load Classification of your application in the AGMA Load Classification Tables on pages 3.6 and 3.7.

3B: Go to the Gearmotor Selection Table that corresponds to the desired Mounting Position and Motor HP. Find the Output Speed closest to the desired output speed.

3C: Locate the Service Class in the Gearmotor Selection Table for your application and select the Frame Size SELECTION that matches the HP, Output Speed, and Service Class.

Select a Frame Size

• Mounting Position

• Motor HP

• Output Speed

• Service Class

• SELECTION

### Double Reduction Selection Tables: Y1, Y2, Y3, Y4, Y5, Y6

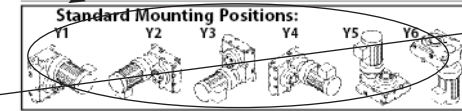

Dimension Pages:  
Single Reduction 3.80-3.85  
Double Reduction 3.86-3.89

	Frequency	50 Hz	60 Hz
	Input Speed	1450 RPM	1750 RPM
	Number of Poles	4	

50Hz			60 Hz			Selection			
Output Speed (RPM)	Output Torque in-lbs (N·m)	Service Factor SF (AGMA Class)	Output Speed (RPM)	Output Torque in-lbs (N·m)	Service Factor SF (AGMA Class)	Motor Power Code	Base Frame Size	Ratio	VFD <sup>(1)</sup>
3.98	72400 (8180)	0.79 - 1.10	4.81	60000 (6780)	0.95 - 1.33	5	D616DC	364	
3.42	84200 (9520)	0.68 - 0.95	4.13	69800 (7880)	0.82 - 1.15	5	D616DC	424	
2.90	99500 (11200)	0.58 - 0.80	3.50	82500 (9320)	0.69 - 0.97	5	D616DC	501	
2.51	115000 (13000)	0.50 - 0.70	3.03	95200 (10800)	0.60 - 0.84	5	D616DC	578	
2.12	136000 (15300)	0.42 - 0.59	2.56	112000 (12700)	0.51 - 0.71	5	D616DC	683	
1.79	161000 (18200)	0.50 -	2.16	133000 (15100)	0.60 -	5	E617DC	809	
1.52	190000 (21500)	0.42 -	1.83	157000 (17800)	0.51 -	5	E617DC	956	

## Step 4: Verify Dimensions

Use the Dimensions information on pages 3.80–3.91 to verify that the selected Frame Size is appropriate.

## Step 5: Choose a Bushing Bore Size

Choose a Taper-Grip® Bushing Bore Size from the Stock Bushing Bore Size Table.

STOCK BUSHING BORES

Size	Inch Sizes	Metric Sizes	Min. Bore
Z	1 <sup>3</sup> / <sub>16</sub> , 1 <sup>7</sup> / <sub>16</sub> ,	30, 40	1 <sup>3</sup> / <sub>16</sub>
A	1 <sup>15</sup> / <sub>16</sub> , 2 <sup>3</sup> / <sub>16</sub>	50, 55	1 <sup>11</sup> / <sub>16</sub>
B	2 <sup>3</sup> / <sub>16</sub> , 2 <sup>7</sup> / <sub>16</sub>	60, 65	1 <sup>15</sup> / <sub>16</sub>
C	2 <sup>7</sup> / <sub>16</sub> , 2 <sup>15</sup> / <sub>16</sub>	65, 75	2 <sup>3</sup> / <sub>16</sub>
D	2 <sup>15</sup> / <sub>16</sub> , 3 <sup>7</sup> / <sub>16</sub>	75, 85	2 <sup>7</sup> / <sub>16</sub>
E	3 <sup>7</sup> / <sub>16</sub> , 3 <sup>15</sup> / <sub>16</sub>	90, 100	2 <sup>15</sup> / <sub>16</sub>

## Step 6: Choose Options

Please refer to Options section 4.1. For additional available options refer to our online Product Configurator at [www.sumitomodrive.com/configurator](http://www.sumitomodrive.com/configurator)

## Step 7: Configure a Model Number

Go to page 3.4 to configure a model number. Note: You will use the information you gather from the procedure on this page to Configure a Model Number.

For special circumstances affecting Frame Size selection such as:

- Overhung Load
- Shock Loading

Consult Appendix, pages 5.7

If Overhung Load is present, it must be checked against the capacity of the selection.



# Configure a Model Number

# Nomenclature

### Output Shaft Orientation

Type	Code
Horizontal	H
Vertical	V

- Include the following information when ordering:**
- Motor Specifications (230/460 VAC 60 Hz is supplied, unless otherwise specified)
  - Taper Grip Bushing or Keyed Hollow Bore diameter (refer to pages 4.2 to 4.3 for diameters)
  - Optional conduit box positions must be specified, or standard is provided, refer to page 5.14
  - Optional Industry Package, refer to page 4.6
  - Specify type for nonstandard torque arm or no torque arm

### Mounting Style

Type	Code
Flange (Keyed Hollow Bore) pg. 4.2	F
Shaft Mount (Hollow Shaft)	Y

### Input Connection

Input Connection	Code
Gearmotor	M

### Frame Size

Single Reduction Input		
Z6090	B6120	D6160
Z6095	B6125	D6165
A6100	C6140	E6170
A6105	C6145	E6175
Double Reduction Input		
Z609DA	C614DB	D616DC
A610DA	C614DC	E617DA
B612DA	D616DA	E617DB
B612DB	D616DB	E617DC
C614DA		

### Modification

	Code
Special	S
Standard	

### Gearmotor HP (applies only to 1750 RPM)

HP	kW	Code
1/8	(0.1)	01
1/4	(0.2)	02
1/3	(0.25)	03
1/2	(0.4)	05
3/4	(0.55)	08
1	(0.75)	1
1 1/2	(1.1)	1H
2	(1.5)	2
3	(2.2)	3
EP 5	(3.7)	5
7 1/2	(5.5)	8
10	(7.5)	10
15	(11)	15
20	(15)	20
25	(18.5)	25
30	(22)	30
40	(30)	40

### AGMA Class

Class	Code
I	A
II	B
III	C

### Motor and Bearing Specification

Specification	Code
AF Motor (Inverter Duty 1/8 HP to 3/4 HP)	AV
Inverter Ready Motor Premium Efficiency (1+HP), IE3	EP
High Capacity Bearing (Required for Screw Conveyor)	R1

Note: When there are multiple suffixes, sequence them alphabetically. Ex.: EPR1

### Brake

	Code
With Brake	B
No Brake	-

### Shaft Specifications

Input Shaft	Hollow Output Shaft	Suffix
mm	Key (mm)	
Inch	Key (Inch)	K
mm	Taper-Grip®	M
Inch	Taper-Grip®	Y

### Mounting Positions (Please see the Appendix, Section 5, for additional mounting positions.)

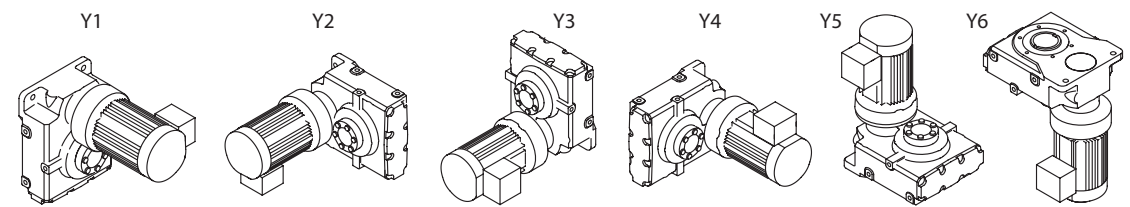

### Nominal Total Ratio

Single Reduction Input		Double Reduction Input	
Input Ratio	Total Ratio	Input Ratio	Total Ratio
3	11	104	364
5	18	121	424
6	21	143	501
8	28	165	578
11	39	195	683
13	46	231	809
15	53	273	956
17	60	319	1117
21	74	377	1320
25	88	473	1656
29	102	559	1957
35	123	649	2272
43	151	731	2559
51	179	841	2944
59	207	1003	3511
71	249	1247	4365
87	305	1479	5177
		1849	6472
		2065	7228
		2537	8880
		3045	10568
		3481	12184
		4437	15530
		5133	17966
		6177	21620
		7569	26492

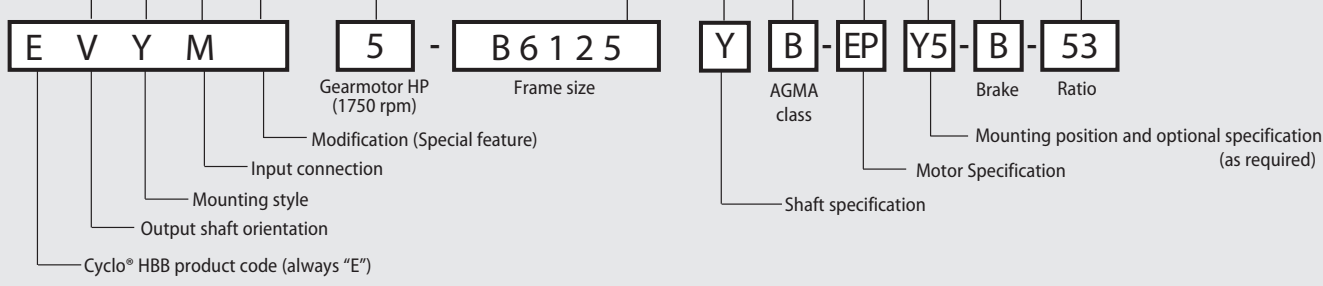

**Nomenclature Example:**  
**EVYM5 - B6125YB - EP Y5 - 53**

E - Cyclo Helical Buddybox  
V - Vertical  
Y - Shaft Mount (Hollow Shaft)  
M - Integral Motor  
5 - 5 HP, 1750 RPM

B6125 - Frame Size  
Y - Inch Shaft Specification  
B - AGMA Class II  
EP - Three-Phase Motor Premium Efficiency  
Y5 - Mounting Position  
53 - Ratio



# Constant Torque Speed Ranges: Gearmotors

This page intentionally left blank.

Table 3.8 Turn Down Ratio (CTSR) for Integral Motors in CONSTANT TORQUE Applications Powered by Inverter VFDs.

Fractional HP Motors - 60 Hz			
Motor Power (4 - Pole)	Standard Motor		AF Motor
	W/o Brake	With Brake	With or Without Brake
1/8 HP (0.1 kW)	2:1	2:1	10:1
1/4 HP (0.2 kW)	2:1	2:1	10:1
1/3 HP (0.25 kW)	2:1	2:1	10:1
1/2 HP (0.4 kW)	2:1	2:1	10:1
3/4 HP (0.55 kW)	2:1	2:1	10:1

Premium Efficiency Integral HP Motors - 60 Hz			
Motor Power (4 - Pole)	Standard Motor		Oversized Motor
	W/o Brake	With Brake	With SSC YA01 Brake
1 HP (0.75 kW)	10:1	10:1	
1.5 HP (1.1 kW)	10:1	5:1	10:1
2 HP (1.5 kW)	10:1	4:1	10:1
3 HP (2.2 kW)	10:1	4:1	10:1
5 HP (3.7 kW)	10:1	4:1	10:1
7.5 HP (5.5 kW)	10:1	4:1	10:1
10 HP (7.5 kW)	10:1	6:1	10:1
15 HP (11 kW)	10:1	6:1	10:1
20 HP (15 kW)	10:1	10:1	
25 HP (18.5 kW)	10:1	10:1	
30 HP (22 kW)	10:1	10:1	
40 HP (30 kW)	10:1	10:1	

For motor selection considerations for inverter (VFD) operation please refer to pages 5.26 and 5.27.

Cyclo® 6000 HBB  
Selection Tables

Cyclo® 6000 HBB  
Selection Tables



# Single Reduction Selection Tables: Y1, Y2, Y3, Y4

**1/8 HP  
(0.1 kW)**

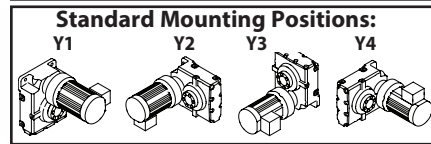

**Selection Table Pages:**

Single Reduction -Y1,Y2,Y3,Y4	3.10-3.38
-Y5,Y6	3.39-3.61
Double Reduction -Y1,Y2,Y3,Y4,Y5,Y6	3.62-3.79

**Dimension Pages:**

Single Reduction	3.80-3.85
Double Reduction	3.86-3.91

Frequency	50 Hz	60 Hz
Input Speed	1450 RPM	1750 RPM
Number of Poles	4	

50Hz				60 Hz				Selection					
Output Speed (RPM)	Output Torque		Service Factor		Output Speed (RPM)	Output Torque		Service Factor		Base			VFD <sup>[1]</sup>
	in-lbs	(N·m)	SF	AGMA Class		in-lbs	(N·m)	SF	AGMA Class	Motor Power Code	Frame Size	Ratio	
7.02	1110	(125)	3.09	III	8.47	920	(104)	3.09	III	01	<b>Z6090</b>	207	(a)
5.84	1340	(151)	2.52	III	7.04	1110	(125)	2.52	III	01	<b>Z6090</b>	249	(a)
			2.78	III				01	<b>Z6095</b>	249	(a)		
4.76	1640	(185)	2.11	III	5.75	1360	(153)	2.11	III	01	<b>Z6090</b>	305	(a)
			2.39	III				01	<b>Z6095</b>	305	(a)		
3.48	2240	(253)	1.25	I	4.20	1850	(210)	1.25	I	01	<b>Z6090</b>	417	(a)
			1.45	II				01	<b>Z6095</b>	417	(a)		

# Single Reduction Selection Tables: Y1, Y2, Y3, Y4

**1/4 HP  
(0.2 kW)**

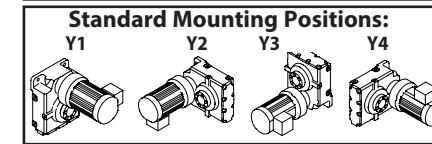

**Selection Table Pages:**

Single Reduction -Y1,Y2,Y3,Y4	3.10-3.38
-Y5,Y6	3.39-3.61
Double Reduction -Y1,Y2,Y3,Y4,Y5,Y6	3.62-3.79

**Dimension Pages:**

Single Reduction	3.80-3.85
Double Reduction	3.86-3.91

Frequency	50 Hz	60 Hz
Input Speed	1450 RPM	1750 RPM
Number of Poles	4	

50Hz				60 Hz				Selection					
Output Speed (RPM)	Output Torque		Service Factor		Output Speed (RPM)	Output Torque		Service Factor		Base			VFD <sup>[1]</sup>
	in-lbs	(N·m)	SF	AGMA Class		in-lbs	(N·m)	SF	AGMA Class	Motor Power Code	Frame Size	Ratio	
14.3	1090	(123)	3.13	III	17.2	904	(102)	3.13	III	02	<b>Z6090</b>	102	(a)
11.8	1320	(149)	2.97	III	14.3	1090	(123)	3.06	III	02	<b>Z6090</b>	123	(a)
			2.97	III				3.58	III	02	<b>Z6095</b>	123	(a)
9.63	1620	(183)	2.18	III	11.6	1340	(151)	2.18	III	02	<b>Z6090</b>	151	(a)
			2.41	III				2.91	III	02	<b>Z6095</b>	151	(a)
8.12	1920	(217)	1.66	II	9.80	1590	(180)	1.66	II	02	<b>Z6090</b>	179	(a)
			2.04	III				2.11	III	02	<b>Z6095</b>	179	(a)
			2.80	III				2.80	III	02	<b>A6100</b>	179	(a)
7.02	2220	(251)	1.54	II	8.47	1840	(208)	1.54	II	02	<b>Z6090</b>	207	(a)
			1.68	II				1.86	II	02	<b>Z6095</b>	207	(a)
			2.58	III				2.58	III	02	<b>A6100</b>	207	(a)
5.84	2670	(302)	1.26	I	7.04	2210	(250)	1.26	I	02	<b>Z6090</b>	249	(a)
			1.39	I				1.51	II	02	<b>Z6095</b>	249	(a)
			2.18	III				2.18	III	02	<b>A6100</b>	249	(a)
			2.53	III				2.81	III	02	<b>A6105</b>	249	(a)
4.76	3270	(370)	1.06	I	5.75	2710	(306)	1.06	I	02	<b>Z6090</b>	305	(a)
			1.19	I				1.44	II	02	<b>Z6095</b>	305	(a)
			2.17	III				2.17	III	02	<b>A6100</b>	305	(a)
			2.39	III				2.83	III	02	<b>A6105</b>	305	(a)
3.48	4480	(506)	1.05	I	4.20	3710	(419)	1.05	I	02	<b>A6100</b>	417	(a)
			1.43	II				1.43	II	02	<b>A6105</b>	417	(a)

**Notes:** [1] Variable Frequency Drive (VFD) notes (see page 3.8 for Constant Torque Speed Ranges):  
 (-) = For Inverter Operation, starting condition may require ambient temperature of 5° C or higher.  
 (a) = Both AV and non-AV motors can be used for selection.

**Notes:** [1] Variable Frequency Drive (VFD) notes (see page 3.8 for Constant Torque Speed Ranges):  
 (-) = For Inverter Operation, starting condition may require ambient temperature of 5° C or higher.  
 (a) = Both AV and non-AV motors can be used for selection.



# Single Reduction Selection Tables: Y1, Y2, Y3, Y4

**3/4 HP  
(0.55 kW)**

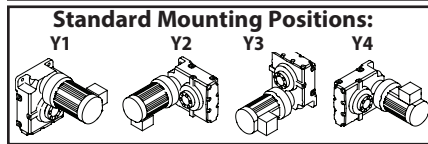

**Selection Table Pages:**  
 Single Reduction  
 -Y1,Y2,Y3,Y4 3.10-3.38  
 -Y5,Y6 3.39-3.61  
 Double Reduction  
 -Y1,Y2,Y3,Y4,Y5,Y6 3.62-3.79

**Dimension Pages:**  
 Single Reduction 3.80-3.85  
 Double Reduction 3.86-3.91

Frequency	50 Hz	60 Hz
Input Speed	1450 RPM	1750 RPM
Number of Poles	4	

50Hz				60 Hz				Selection					
Output Speed (RPM)	Output Torque		Service Factor		Output Speed (RPM)	Output Torque		Service Factor		Base			VFD <sup>[1]</sup>
	in-lbs	(N·m)	SF	AGMA Class		in-lbs	(N·m)	SF	AGMA Class	Motor Power Code	Frame Size	Ratio	
69.0	621	(70.1)	2.08	III	83.3	514	(58.1)	2.08	III	08	<b>Z6090</b>	21	(a)
			2.75	III				08	<b>Z6095</b>	21	(a)		
51.8	828	(93.5)	2.08	III	62.5	686	(77.5)	2.08	III	08	<b>Z6090</b>	28	(a)
			2.75	III				08	<b>Z6095</b>	28	(a)		
37.7	1140	(129)	2.08	III	45.5	943	(107)	2.08	III	08	<b>Z6090</b>	39	(a)
			2.75	III				08	<b>Z6095</b>	39	(a)		
31.9	1340	(152)	2.08	III	38.5	1110	(126)	2.08	III	08	<b>Z6090</b>	46	(a)
			2.75	III				08	<b>Z6095</b>	46	(a)		
27.6	1550	(175)	2.08	III	33.3	1290	(145)	2.08	III	08	<b>Z6090</b>	53	(a)
			2.52	III				08	<b>Z6095</b>	53	(a)		
24.4	1760	(199)	2.08	III	29.4	1460	(165)	2.08	III	08	<b>Z6090</b>	60	(a)
			2.22	III				08	<b>Z6095</b>	60	(a)		
19.7	2170	(245)	1.38	I	23.8	1800	(203)	1.38	I	08	<b>Z6090</b>	74	(a)
			1.80	II				08	<b>Z6095</b>	74	(a)		
16.6	2590	(292)	1.22	I	20.0	2140	(242)	1.22	I	08	<b>Z6090</b>	88	(a)
			1.51	II				08	<b>Z6095</b>	88	(a)		
			2.31	III				08	<b>A6100</b>	88	(a)		
			3.02	III				08	<b>A6105</b>	88	(a)		
14.3	3000	(339)	1.14	I	17.2	2490	(281)	1.14	I	08	<b>Z6090</b>	102	(a)
			1.30	I				08	<b>Z6095</b>	102	(a)		
			2.20	III				08	<b>A6100</b>	102	(a)		
			2.61	III				08	<b>A6105</b>	102	(a)		
11.8	3620	(409)	1.08	I	14.3	3000	(339)	1.11	I	08	<b>Z6090</b>	123	(a)
			1.08	I				08	<b>Z6095</b>	123	(a)		
			1.77	II				08	<b>A6100</b>	123	(a)		
			2.16	III				08	<b>A6105</b>	123	(a)		
9.63	4450	(503)	0.88	-	11.6	3690	(416)	1.06	I	08	<b>Z6095</b>	151	(a)
			1.42	II				08	<b>A6100</b>	151	(a)		
			1.76	II				08	<b>A6105</b>	151	(a)		
8.12	5280	(596)	1.02	I	9.80	4370	(494)	1.02	I	08	<b>A6100</b>	179	(a)
			1.41	II				08	<b>A6105</b>	179	(a)		
			2.96	III				08	<b>B6120</b>	179	(a)		
			2.97	III				08	<b>B6125</b>	179	(a)		
7.02	6100	(690)	0.94	-	8.47	5060	(571)	0.94	-	08	<b>A6100</b>	207	(a)
			1.24	I				08	<b>A6105</b>	207	(a)		
			2.36	III				08	<b>B6120</b>	207	(a)		
			2.57	III				08	<b>B6125</b>	207	(a)		

**Notes:** [1] Variable Frequency Drive (VFD) notes (see page 3.8 for Constant Torque Speed Ranges):  
 (-) = For Inverter Operation, starting condition may require ambient temperature of 5° C or higher.  
 (a) = Both AV and non-AV motors can be used for selection.

# Single Reduction Selection Tables: Y1, Y2, Y3, Y4

**3/4 HP  
(0.55 kW)**

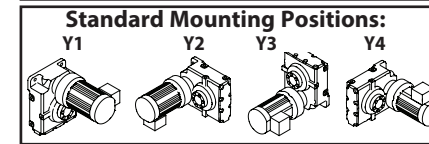

**Selection Table Pages:**  
 Single Reduction  
 -Y1,Y2,Y3,Y4 3.10-3.38  
 -Y5,Y6 3.39-3.61  
 Double Reduction  
 -Y1,Y2,Y3,Y4,Y5,Y6 3.62-3.79

**Dimension Pages:**  
 Single Reduction 3.80-3.85  
 Double Reduction 3.86-3.91

Frequency	50 Hz	60 Hz
Input Speed	1450 RPM	1750 RPM
Number of Poles	4	

50Hz				60 Hz				Selection					
Output Speed (RPM)	Output Torque		Service Factor		Output Speed (RPM)	Output Torque		Service Factor		Base			VFD <sup>[1]</sup>
	in-lbs	(N·m)	SF	AGMA Class		in-lbs	(N·m)	SF	AGMA Class	Motor Power Code	Frame Size	Ratio	
5.84	7350	(830)	0.92	-	7.04	6090	(688)	1.02	I	08	<b>A6105</b>	249	(a)
			1.74	II				08	<b>B6120</b>	249	(a)		
			2.07	III				08	<b>B6125</b>	249	(a)		
4.76	9000	(1020)	0.87	-	5.75	7460	(843)	1.03	I	08	<b>A6105</b>	305	(a)
			1.72	II				08	<b>B6120</b>	305	(a)		
			1.74	II				08	<b>B6125</b>	305	(a)		

**Notes:** [1] Variable Frequency Drive (VFD) notes (see page 3.8 for Constant Torque Speed Ranges):  
 (-) = For Inverter Operation, starting condition may require ambient temperature of 5° C or higher.  
 (a) = Both AV and non-AV motors can be used for selection.

# Single Reduction Selection Tables: Y1, Y2, Y3, Y4

**1 HP  
(0.75 kW)**

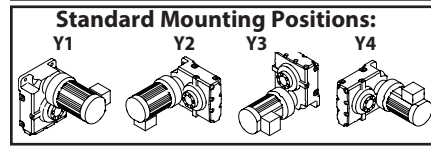

**Selection Table Pages:**

Single Reduction -Y1,Y2,Y3,Y4	3.10-3.38
-Y5,Y6	3.39-3.61
Double Reduction -Y1,Y2,Y3,Y4,Y5,Y6	3.62-3.79

**Dimension Pages:**

Single Reduction	3.80-3.85
Double Reduction	3.86-3.91

Frequency	50 Hz	60 Hz
Input Speed	1450 RPM	1750 RPM
Number of Poles	4	

50Hz				60 Hz				Selection					
Output Speed (RPM)	Output Torque		Service Factor		Output Speed (RPM)	Output Torque		Service Factor		Base			VFD <sup>[1]</sup>
	in-lbs	(N·m)	SF	AGMA Class		in-lbs	(N·m)	SF	AGMA Class	Motor Power Code	Frame Size	Ratio	
138	423	(47.8)	3.13	III	167	351	(39.6)	3.13	III	1	<b>A6100</b>	11	
69.0	847	(95.6)	1.53	II	83.3	701	(79.2)	1.53	II	1	<b>Z6090</b>	21	
			2.02	III				1	<b>Z6095</b>	21			
			3.13	III				1	<b>A6100</b>	21			
			3.13	III				1	<b>A6100</b>	21			
51.8	1130	(128)	1.53	II	62.5	935	(106)	1.53	II	1	<b>Z6090</b>	28	
			2.02	III				1	<b>Z6095</b>	28			
			3.13	III				1	<b>A6100</b>	28			
37.7	1550	(175)	1.53	II	45.5	1290	(145)	1.53	II	1	<b>Z6090</b>	39	
			2.02	III				1	<b>Z6095</b>	39			
			3.13	III				1	<b>A6100</b>	39			
31.9	1830	(207)	1.53	II	38.5	1520	(172)	1.53	II	1	<b>Z6090</b>	46	
			2.02	III				1	<b>Z6095</b>	46			
			3.13	III				1	<b>A6100</b>	46			
27.6	2120	(239)	1.53	II	33.3	1750	(198)	1.53	II	1	<b>Z6090</b>	53	
			1.85	II				1	<b>Z6095</b>	53			
			3.13	III				1	<b>A6100</b>	53			
24.4	2400	(271)	1.53	II	29.4	1990	(225)	1.53	II	1	<b>Z6090</b>	60	
			1.63	II				1	<b>Z6095</b>	60			
			2.65	III				1	<b>A6100</b>	60			
19.7	2960	(335)	1.01	I	23.8	2450	(277)	1.01	I	1	<b>Z6090</b>	74	
			1.32	I				1	<b>Z6095</b>	74			
			2.53	III				1	<b>A6100</b>	74			
			2.64	III				1	<b>A6105</b>	74			
16.6	3530	(399)	0.89	-	20.0	2920	(330)	0.89	-	1	<b>Z6090</b>	88	
			1.11	I				1	<b>Z6095</b>	88			
			1.69	II				1	<b>A6100</b>	88			
			2.22	III				1	<b>A6105</b>	88			
14.3	4090	(462)	0.83	-	17.2	3390	(383)	0.83	-	1	<b>Z6090</b>	102	
			0.95	-				1	<b>Z6095</b>	102			
			1.61	II				1	<b>A6100</b>	102			
			1.91	II				1	<b>A6105</b>	102			
11.8	4940	(558)	0.79	-	14.3	4090	(462)	0.82	-	1	<b>Z6090</b>	123	
			0.79	-				1	<b>Z6095</b>	123			
			1.30	I				1	<b>A6100</b>	123			
			1.58	II				1	<b>A6105</b>	123			
			3.16	III				1	<b>B6120</b>	123			
			3.17	III				1	<b>B6125</b>	123			

**Notes:** [1] Variable Frequency Drive (VFD) notes (see page 3.8 for Constant Torque Speed Ranges):  
 (-) = For Inverter Operation, starting condition may require ambient temperature of 5° C or higher.  
 (a) = Both AV and non-AV motors can be used for selection.

# Single Reduction Selection Tables: Y1, Y2, Y3, Y4

**1 HP  
(0.75 kW)**

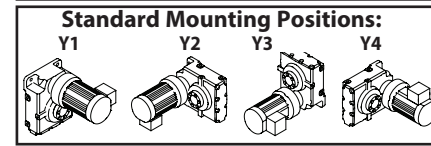

**Selection Table Pages:**

Single Reduction -Y1,Y2,Y3,Y4	3.10-3.38
-Y5,Y6	3.39-3.61
Double Reduction -Y1,Y2,Y3,Y4,Y5,Y6	3.62-3.79

**Dimension Pages:**

Single Reduction	3.80-3.85
Double Reduction	3.86-3.91

Frequency	50 Hz	60 Hz
Input Speed	1450 RPM	1750 RPM
Number of Poles	4	

50Hz				60 Hz				Selection					
Output Speed (RPM)	Output Torque		Service Factor		Output Speed (RPM)	Output Torque		Service Factor		Base			VFD <sup>[1]</sup>
	in-lbs	(N·m)	SF	AGMA Class		in-lbs	(N·m)	SF	AGMA Class	Motor Power Code	Frame Size	Ratio	
9.63	6070	(685)	1.04	I	11.6	5030	(568)	1.04	I	1	<b>A6100</b>	151	
			1.29	I				1	<b>A6105</b>	151			
			2.55	III				1	<b>B6120</b>	151			
			2.58	III				1	<b>B6125</b>	151			
8.12	7200	(813)	1.03	I	9.80	5960	(674)	1.03	I	1	<b>A6105</b>	179	
			2.17	III				1	<b>B6120</b>	179			
			2.18	III				1	<b>B6125</b>	179			
7.02	8320	(940)	0.91	-	8.47	6900	(779)	0.94	-	1	<b>A6105</b>	207	
			1.73	II				1	<b>B6120</b>	207			
			1.88	II				1	<b>B6125</b>	207			
5.84	10000	(1130)	1.28	I	7.04	8300	(938)	1.28	I	1	<b>B6120</b>	249	
			1.52	II				1	<b>B6125</b>	249			
			3.13	III				1	<b>C6140</b>	249			
			3.13	III				1	<b>C6145</b>	249			
4.76	12300	(1390)	1.26	I	5.75	10200	(1150)	1.26	I	1	<b>B6120</b>	305	
			1.28	I				1	<b>B6125</b>	305			
			2.55	III				1	<b>C6140</b>	305			
			2.55	III				1	<b>C6145</b>	305			

**Notes:** [1] Variable Frequency Drive (VFD) notes (see page 3.8 for Constant Torque Speed Ranges):  
 (-) = For Inverter Operation, starting condition may require ambient temperature of 5° C or higher.  
 (a) = Both AV and non-AV motors can be used for selection.

# Single Reduction Selection Tables: Y1, Y2, Y3, Y4

**1.5 HP  
(1.1 kW)**

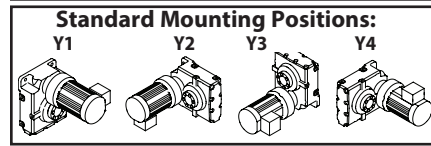

**Selection Table Pages:**  
 Single Reduction  
 -Y1,Y2,Y3,Y4 3.10-3.38  
 -Y5,Y6 3.39-3.61  
 Double Reduction  
 -Y1,Y2,Y3,Y4,Y5,Y6 3.62-3.79

**Dimension Pages:**  
 Single Reduction 3.80-3.85  
 Double Reduction 3.86-3.91

Frequency	50 Hz	60 Hz
Input Speed	1450 RPM	1750 RPM
Number of Poles	4	

50Hz				60 Hz				Selection				VFD <sup>[1]</sup>
Output Speed (RPM)	Output Torque		Service Factor		Output Speed (RPM)	Output Torque		Service Factor		Base		
	in-lbs	(N·m)	SF	AGMA Class		in-lbs	(N·m)	SF	AGMA Class	Motor Power Code	Frame Size	Ratio
138	621	(70.1)	2.14	III	167	514	(58.1)	2.14	III	1H	<b>A6100</b>	11
			2.89	III				1H	<b>A6105</b>	11		
82.9	1030	(117)	2.23	III	100	857	(96.9)	2.23	III	1H	<b>A6100</b>	18
			3.01	III				1H	<b>A6105</b>	18		
69.0	1240	(140)	1.04	I	83.3	1030	(116)	1.04	I	1H	<b>Z6090</b>	21
			1.38	I				1H	<b>Z6095</b>	21		
			2.13	III				1H	<b>A6100</b>	21		
			2.89	III				1H	<b>A6105</b>	21		
51.8	1660	(187)	1.04	I	62.5	1370	(155)	1.04	I	1H	<b>Z6090</b>	28
			1.38	I				1H	<b>Z6095</b>	28		
			2.13	III				1H	<b>A6100</b>	28		
			2.89	III				1H	<b>A6105</b>	28		
37.7	2280	(257)	1.04	I	45.5	1890	(213)	1.04	I	1H	<b>Z6090</b>	39
			1.38	I				1H	<b>Z6095</b>	39		
			2.13	III				1H	<b>A6100</b>	39		
			2.89	III				1H	<b>A6105</b>	39		
31.9	2690	(304)	1.04	I	38.5	2230	(252)	1.04	I	1H	<b>Z6090</b>	46
			1.38	I				1H	<b>Z6095</b>	46		
			2.13	III				1H	<b>A6100</b>	46		
			2.89	III				1H	<b>A6105</b>	46		
27.6	3100	(351)	1.04	I	33.3	2570	(291)	1.04	I	1H	<b>Z6090</b>	53
			1.26	I				1H	<b>Z6095</b>	53		
			2.13	III				1H	<b>A6100</b>	53		
			2.52	III				1H	<b>A6105</b>	53		
24.4	3520	(397)	1.04	I	29.4	2910	(329)	1.04	I	1H	<b>Z6090</b>	60
			1.11	I				1H	<b>Z6095</b>	60		
			1.81	II				1H	<b>A6100</b>	60		
			2.22	III				1H	<b>A6105</b>	60		
19.7	4350	(491)	0.90	-	23.8	3600	(407)	1.08	I	1H	<b>Z6095</b>	74
			1.73	II				1H	<b>A6100</b>	74		
			1.80	II				1H	<b>A6105</b>	74		
16.6	5170	(584)	1.15	I	20.0	4290	(484)	1.15	I	1H	<b>A6100</b>	88
			1.51	II				1H	<b>A6105</b>	88		
			2.81	III				1H	<b>B6120</b>	88		
			3.03	III				1H	<b>B6125</b>	88		

**Notes:** [1] Variable Frequency Drive (VFD) notes (see page 3.8 for Constant Torque Speed Ranges):  
 (-) = For Inverter Operation, starting condition may require ambient temperature of 5° C or higher.  
 (a) = Both AV and non-AV motors can be used for selection.

# Single Reduction Selection Tables: Y1, Y2, Y3, Y4

**1.5 HP  
(1.1 kW)**

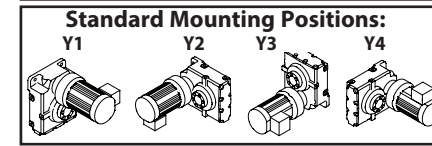

**Selection Table Pages:**  
 Single Reduction  
 -Y1,Y2,Y3,Y4 3.10-3.38  
 -Y5,Y6 3.39-3.61  
 Double Reduction  
 -Y1,Y2,Y3,Y4,Y5,Y6 3.62-3.79

**Dimension Pages:**  
 Single Reduction 3.80-3.85  
 Double Reduction 3.86-3.91

Frequency	50 Hz	60 Hz
Input Speed	1450 RPM	1750 RPM
Number of Poles	4	

50Hz				60 Hz				Selection				VFD <sup>[1]</sup>
Output Speed (RPM)	Output Torque		Service Factor		Output Speed (RPM)	Output Torque		Service Factor		Base		
	in-lbs	(N·m)	SF	AGMA Class		in-lbs	(N·m)	SF	AGMA Class	Motor Power Code	Frame Size	Ratio
14.3	6000	(678)	1.10	I	17.2	4970	(562)	1.10	I	1H	<b>A6100</b>	102
			1.30	I				1H	<b>A6105</b>	102		
			2.61	III				1H	<b>B6120</b>	102		
			2.61	III				1H	<b>B6125</b>	102		
11.8	7240	(818)	0.89	-	14.3	6000	(678)	0.89	-	1H	<b>A6100</b>	123
			1.08	I				1H	<b>A6105</b>	123		
			2.15	III				1H	<b>B6120</b>	123		
			2.16	III				1H	<b>B6125</b>	123		
9.63	8900	(1010)	0.88	-	11.6	7370	(833)	0.98	-	1H	<b>A6105</b>	151
			1.74	II				1H	<b>B6120</b>	151		
			1.76	II				1H	<b>B6125</b>	151		
8.12	10600	(1190)	1.48	II	9.80	8740	(988)	1.56	II	1H	<b>B6120</b>	179
			1.48	II				1H	<b>B6125</b>	179		
			2.97	III				1H	<b>C6140</b>	179		
			2.97	III				1H	<b>C6145</b>	179		
7.02	12200	(1380)	1.18	I	8.47	10100	(1140)	1.18	I	1H	<b>B6120</b>	207
			1.28	I				1H	<b>B6125</b>	207		
			2.57	III				1H	<b>C6140</b>	207		
			2.57	III				1H	<b>C6145</b>	207		
5.84	14700	(1660)	0.87	-	7.04	12200	(1380)	0.87	-	1H	<b>B6120</b>	249
			1.03	I				1H	<b>B6125</b>	249		
			2.13	III				1H	<b>C6140</b>	249		
			2.13	III				1H	<b>C6145</b>	249		
			3.15	III				1H	<b>D6160</b>	249		
4.76	18000	(2030)	0.86	-	5.75	14900	(1690)	0.86	-	1H	<b>B6120</b>	305
			0.87	-				1H	<b>B6125</b>	305		
			1.74	II				1H	<b>C6140</b>	305		
			1.74	II				1H	<b>C6145</b>	305		
			2.93	III				1H	<b>D6160</b>	305		
			3.05	III				1H	<b>D6165</b>	305		

**Notes:** [1] Variable Frequency Drive (VFD) notes (see page 3.8 for Constant Torque Speed Ranges):  
 (-) = For Inverter Operation, starting condition may require ambient temperature of 5° C or higher.  
 (a) = Both AV and non-AV motors can be used for selection.

# Single Reduction Selection Tables: Y1, Y2, Y3, Y4

**2 HP  
(1.5 kW)**

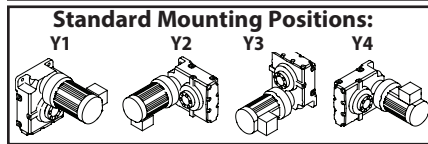

**Selection Table Pages:**  
Single Reduction  
-Y1,Y2,Y3,Y4 3.10-3.38  
-Y5,Y6 3.39-3.61  
Double Reduction  
-Y1,Y2,Y3,Y4,Y5,Y6 3.62-3.79

**Dimension Pages:**  
Single Reduction 3.80-3.85  
Double Reduction 3.86-3.91

Frequency	50 Hz	60 Hz
Input Speed	1450 RPM	1750 RPM
Number of Poles	4	

50Hz				60 Hz				Selection				VFD <sup>[1]</sup>
Output Speed (RPM)	Output Torque		Service Factor		Output Speed (RPM)	Output Torque		Service Factor		Base		
	in-lbs	(N·m)	SF	AGMA Class		in-lbs	(N·m)	SF	AGMA Class	Motor Power Code	Frame Size	Ratio
138	847	(95.6)	1.57	II	167	701	(79.2)	1.57	II	2	<b>A6100</b>	11
			2.12	III				2	<b>A6105</b>	11		
82.9	1410	(159)	1.63	II	100	1170	(132)	1.63	II	2	<b>A6100</b>	18
			2.21	III				2	<b>A6105</b>	18		
69.0	1690	(191)	1.01	I	83.3	1400	(158)	1.01	I	2	<b>Z6095</b>	21
			1.56	II				2	<b>A6100</b>	21		
			2.12	III				2	<b>A6105</b>	21		
51.8	2260	(255)	1.01	I	62.5	1870	(211)	1.01	I	2	<b>Z6095</b>	28
			1.56	II				2	<b>A6100</b>	28		
			2.12	III				2	<b>A6105</b>	28		
37.7	3100	(351)	1.01	I	45.5	2570	(291)	1.01	I	2	<b>Z6095</b>	39
			1.56	II				2	<b>A6100</b>	39		
			2.12	III				2	<b>A6105</b>	39		
			2.12	III				2	<b>A6105</b>	39		
31.9	3670	(414)	1.01	I	38.5	3040	(343)	1.01	I	2	<b>Z6095</b>	46
			1.56	II				2	<b>A6100</b>	46		
			2.12	III				2	<b>A6105</b>	46		
27.6	4230	(478)	0.92	-	33.3	3510	(396)	1.01	I	2	<b>Z6095</b>	53
			1.56	II				2	<b>A6100</b>	53		
			1.85	II				2	<b>A6105</b>	53		
24.4	4800	(542)	0.81	-	29.4	3970	(449)	0.98	-	2	<b>Z6095</b>	60
			1.32	I				2	<b>A6100</b>	60		
			1.63	II				2	<b>A6105</b>	60		
			1.63	II				2	<b>A6105</b>	60		
19.7	5930	(669)	0.66	-	23.8	4910	(555)	0.80	-	2	<b>Z6095</b>	74
			1.27	I				2	<b>A6100</b>	74		
			1.32	I				2	<b>A6105</b>	74		
			2.64	III				2	<b>B6120</b>	74		
			2.64	III				2	<b>B6125</b>	74		
16.6	7050	(797)	0.85	-	20.0	5840	(660)	0.85	-	2	<b>A6100</b>	88
			1.11	I				2	<b>A6105</b>	88		
			2.06	III				2	<b>B6120</b>	88		
			2.22	III				2	<b>B6125</b>	88		
14.3	8180	(925)	0.81	-	17.2	6780	(766)	0.81	-	2	<b>A6100</b>	102
			0.96	-				2	<b>A6105</b>	102		
			1.91	II				2	<b>B6120</b>	102		
			1.91	II				2	<b>B6125</b>	102		
			2.31	III				2	<b>B6125</b>	102		

**Notes:** [1] Variable Frequency Drive (VFD) notes (see page 3.8 for Constant Torque Speed Ranges):  
(-) = For Inverter Operation, starting condition may require ambient temperature of 5° C or higher.  
(a) = Both AV and non-AV motors can be used for selection.

# Single Reduction Selection Tables: Y1, Y2, Y3, Y4

**2 HP  
(1.5 kW)**

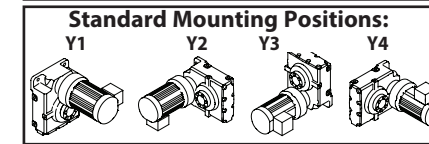

**Selection Table Pages:**  
Single Reduction  
-Y1,Y2,Y3,Y4 3.10-3.38  
-Y5,Y6 3.39-3.61  
Double Reduction  
-Y1,Y2,Y3,Y4,Y5,Y6 3.62-3.79

**Dimension Pages:**  
Single Reduction 3.80-3.85  
Double Reduction 3.86-3.91

Frequency	50 Hz	60 Hz
Input Speed	1450 RPM	1750 RPM
Number of Poles	4	

50Hz				60 Hz				Selection				VFD <sup>[1]</sup>
Output Speed (RPM)	Output Torque		Service Factor		Output Speed (RPM)	Output Torque		Service Factor		Base		
	in-lbs	(N·m)	SF	AGMA Class		in-lbs	(N·m)	SF	AGMA Class	Motor Power Code	Frame Size	Ratio
11.8	9880	(1120)	0.79	-	14.3	8180	(925)	0.80	-	2	<b>A6105</b>	123
			1.58	II				2	<b>B6120</b>	123		
			1.59	II				2	<b>B6125</b>	123		
			3.17	III				2	<b>C6140</b>	123		
			3.17	III				2	<b>C6145</b>	123		
9.63	12100	(1370)	1.27	I	11.6	10100	(1140)	1.27	I	2	<b>B6120</b>	151
			1.29	I				2	<b>B6125</b>	151		
			2.58	III				2	<b>C6140</b>	151		
8.12	14400	(1630)	1.09	I	9.80	11900	(1350)	1.14	I	2	<b>B6120</b>	179
			1.09	I				2	<b>B6125</b>	179		
			2.18	III				2	<b>C6140</b>	179		
			2.18	III				2	<b>C6145</b>	179		
7.02	16600	(1880)	0.87	-	8.47	13800	(1560)	0.87	-	2	<b>B6120</b>	207
			0.94	-				2	<b>B6125</b>	207		
			1.88	II				2	<b>C6140</b>	207		
			1.88	II				2	<b>C6145</b>	207		
			2.95	III				2	<b>D6160</b>	207		
5.84	20000	(2260)	0.76	-	7.04	16600	(1880)	0.80	-	2	<b>B6125</b>	249
			1.56	II				2	<b>C6140</b>	249		
			1.56	II				2	<b>C6145</b>	249		
			2.31	III				2	<b>D6160</b>	249		
			2.74	III				2	<b>D6165</b>	249		
4.76	24500	(2770)	1.28	I	5.75	20300	(2300)	1.32	I	2	<b>C6140</b>	305
			1.28	I				2	<b>C6145</b>	305		
			2.15	III				2	<b>D6160</b>	305		
			2.24	III				2	<b>D6165</b>	305		

**Notes:** [1] Variable Frequency Drive (VFD) notes (see page 3.8 for Constant Torque Speed Ranges):  
(-) = For Inverter Operation, starting condition may require ambient temperature of 5° C or higher.  
(a) = Both AV and non-AV motors can be used for selection.

# Single Reduction Selection Tables: Y1, Y2, Y3, Y4

**3 HP  
(2.2 kW)**

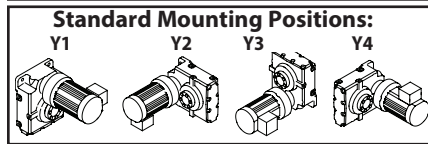

**Selection Table Pages:**  
Single Reduction -Y1,Y2,Y3,Y4 3.10-3.38  
-Y5,Y6 3.39-3.61  
Double Reduction -Y1,Y2,Y3,Y4,Y5,Y6 3.62-3.79

**Dimension Pages:**  
Single Reduction 3.80-3.85  
Double Reduction 3.86-3.91

Frequency	50 Hz	60 Hz
Input Speed	1450 RPM	1750 RPM
Number of Poles	4	

50Hz				60 Hz				Selection				VFD <sup>[1]</sup>
Output Speed (RPM)	Output Torque		Service Factor		Output Speed (RPM)	Output Torque		Service Factor		Base		
	in-lbs	(N·m)	SF	AGMA Class		in-lbs	(N·m)	SF	AGMA Class	Motor Power Code	Frame Size	Ratio
138	1240	(140)	1.07	I	167	1030	(116)	1.07	I	3	A6100	11
			1.45	II				3	A6105	11		
			2.30	III				3	B6120	11		
			2.82	III				3	B6125	11		
82.9	2070	(234)	1.11	I	100	1710	(194)	1.11	I	3	A6100	18
			1.51	II				3	A6105	18		
			2.35	III				3	B6120	18		
			2.88	III				3	B6125	18		
69.0	2480	(281)	1.07	I	83.3	2060	(232)	1.07	I	3	A6100	21
			1.45	II				3	A6105	21		
			2.30	III				3	B6120	21		
			3.16	III				3	B6125	21		
51.8	3310	(374)	1.07	I	62.5	2740	(310)	1.07	I	3	A6100	28
			1.45	II				3	A6105	28		
			2.30	III				3	B6120	28		
			3.16	III				3	B6125	28		
37.7	4550	(514)	1.07	I	45.5	3770	(426)	1.07	I	3	A6100	39
			1.45	II				3	A6105	39		
			2.30	III				3	B6120	39		
			2.69	III				3	B6125	39		
31.9	5380	(608)	1.07	I	38.5	4460	(504)	1.07	I	3	A6100	46
			1.45	II				3	A6105	46		
			2.30	III				3	B6120	46		
			2.69	III				3	B6125	46		
27.6	6210	(701)	1.07	I	33.3	5140	(581)	1.07	I	3	A6100	53
			1.26	I				3	A6105	53		
			2.30	III				3	B6120	53		
			2.52	III				3	B6125	53		
24.4	7040	(795)	0.90	-	29.4	5830	(659)	0.90	-	3	A6100	60
			1.11	I				3	A6105	60		
			2.22	III				3	B6120	60		
			2.23	III				3	B6125	60		
19.7	8690	(982)	0.86	-	23.8	7200	(814)	0.88	-	3	A6100	74
			0.90	-				3	A6105	74		
			1.80	II				3	B6120	74		
			1.80	II				3	B6125	74		

# Single Reduction Selection Tables: Y1, Y2, Y3, Y4

**3 HP  
(2.2 kW)**

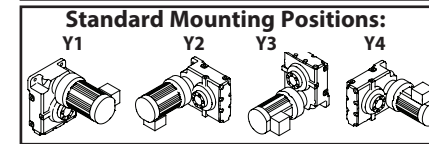

**Selection Table Pages:**  
Single Reduction -Y1,Y2,Y3,Y4 3.10-3.38  
-Y5,Y6 3.39-3.61  
Double Reduction -Y1,Y2,Y3,Y4,Y5,Y6 3.62-3.79

**Dimension Pages:**  
Single Reduction 3.80-3.85  
Double Reduction 3.86-3.91

Frequency	50 Hz	60 Hz
Input Speed	1450 RPM	1750 RPM
Number of Poles	4	

50Hz				60 Hz				Selection				VFD <sup>[1]</sup>
Output Speed (RPM)	Output Torque		Service Factor		Output Speed (RPM)	Output Torque		Service Factor		Base		
	in-lbs	(N·m)	SF	AGMA Class		in-lbs	(N·m)	SF	AGMA Class	Motor Power Code	Frame Size	Ratio
16.6	10300	(1170)	1.40	II	20.0	8570	(969)	1.40	II	3	B6120	88
			1.51	II				3	B6125	88		
			3.03	III				3	C6140	88		
			3.03	III				3	C6145	88		
			3.03	III				3	C6145	88		
14.3	12000	(1360)	1.30	I	17.2	9940	(1120)	1.36	I	3	B6120	102
			1.31	I				3	B6125	102		
			2.61	III				3	C6140	102		
			2.61	III				3	C6145	102		
			2.61	III				3	C6145	102		
11.8	14500	(1640)	1.08	I	14.3	12000	(1360)	1.13	I	3	B6120	123
			1.08	I				3	B6125	123		
			2.16	III				3	C6140	123		
			2.16	III				3	C6145	123		
			2.16	III				3	C6145	123		
9.63	17800	(2010)	0.87	-	11.6	14700	(1670)	0.87	-	3	B6120	151
			0.88	-				3	B6125	151		
			1.76	II				3	C6140	151		
			1.76	II				3	C6145	151		
			2.93	III				3	D6160	151		
			3.08	III				3	D6165	151		
			3.08	III				3	D6165	151		
8.12	21100	(2380)	0.74	-	9.80	17500	(1980)	0.90	-	3	B6125	179
			1.48	II				3	C6140	179		
			1.48	II				3	C6145	179		
			2.50	III				3	D6160	179		
			2.60	III				3	D6165	179		
7.02	24400	(2760)	1.28	I	8.47	20200	(2290)	1.35	I	3	C6140	207
			1.28	I				3	C6145	207		
			2.01	III				3	D6160	207		
			2.25	III				3	D6165	207		
			3.01	III				3	E6170	207		
			3.14	III				3	E6175	207		
5.84	29400	(3320)	1.07	I	7.04	24300	(2750)	1.10	I	3	C6140	249
			1.07	I				3	C6145	249		
			1.58	II				3	D6160	249		
			1.87	II				3	D6165	249		
			2.50	III				3	E6170	249		
2.61	III	3	E6175	249								

**Notes:** [1] Variable Frequency Drive (VFD) notes (see page 3.8 for Constant Torque Speed Ranges):  
(-) = For Inverter Operation, starting condition may require ambient temperature of 5° C or higher.  
(a) = Both AV and non-AV motors can be used for selection.

**Notes:** [1] Variable Frequency Drive (VFD) notes (see page 3.8 for Constant Torque Speed Ranges):  
(-) = For Inverter Operation, starting condition may require ambient temperature of 5° C or higher.  
(a) = Both AV and non-AV motors can be used for selection.

# Single Reduction Selection Tables: Y1, Y2, Y3, Y4

**3 HP  
(2.2 kW)**

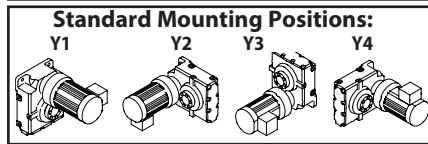

**Selection Table Pages:**

Single Reduction -Y1,Y2,Y3,Y4	3.10-3.38
-Y5,Y6	3.39-3.61
Double Reduction -Y1,Y2,Y3,Y4,Y5,Y6	3.62-3.79

**Dimension Pages:**

Single Reduction	3.80-3.85
Double Reduction	3.86-3.91

Frequency	50 Hz	60 Hz
Input Speed	1450 RPM	1750 RPM
Number of Poles	4	

50Hz			60 Hz			Selection			VFD <sup>[1]</sup>	
Output Speed (RPM)	Output Torque		Output Speed (RPM)	Output Torque		Base				
	in-lbs	(N·m)		in-lbs	(N·m)	Motor Power Code	Frame Size	Ratio		
4.76	36000	(4070)	5.75	29800	(3370)	0.87	-	3	<b>C6140</b>	305
						0.87	-	3	<b>C6145</b>	305
						1.47	II	3	<b>D6160</b>	305
						1.52	II	3	<b>D6165</b>	305
						2.08	III	3	<b>E6170</b>	305
						2.13	III	3	<b>E6175</b>	305

# Single Reduction Selection Tables: Y1, Y2, Y3, Y4

**5 HP  
(3.7 kW)**

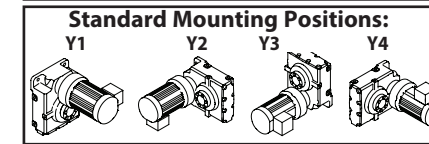

**Selection Table Pages:**

Single Reduction -Y1,Y2,Y3,Y4	3.10-3.38
-Y5,Y6	3.39-3.61
Double Reduction -Y1,Y2,Y3,Y4,Y5,Y6	3.62-3.79

**Dimension Pages:**

Single Reduction	3.80-3.85
Double Reduction	3.86-3.91

Frequency	50 Hz	60 Hz
Input Speed	1450 RPM	1750 RPM
Number of Poles	4	

50Hz			60 Hz			Selection			VFD <sup>[1]</sup>	
Output Speed (RPM)	Output Torque		Output Speed (RPM)	Output Torque		Base				
	in-lbs	(N·m)		in-lbs	(N·m)	Motor Power Code	Frame Size	Ratio		
138	2090	(236)	167	1730	(195)	1.37	I	5	<b>B6120</b>	11
						1.68	II	5	<b>B6125</b>	11
82.9	3480	(393)	100	2880	(326)	1.40	II	5	<b>B6120</b>	18
						1.71	II	5	<b>B6125</b>	18
69.0	4180	(472)	83.3	3460	(391)	1.37	I	5	<b>B6120</b>	21
						1.88	II	5	<b>B6125</b>	21
51.8	5570	(629)	62.5	4610	(521)	1.37	I	5	<b>B6120</b>	28
						1.88	II	5	<b>B6125</b>	28
37.7	7660	(865)	45.5	6340	(717)	1.37	I	5	<b>B6120</b>	39
						1.60	II	5	<b>B6125</b>	39
31.9	9050	(1020)	38.5	7500	(847)	1.37	I	5	<b>B6120</b>	46
						1.60	II	5	<b>B6125</b>	46
27.6	10400	(1180)	33.3	8650	(977)	1.37	I	5	<b>B6120</b>	53
						1.50	II	5	<b>B6125</b>	53
						3.00	III	5	<b>C6140</b>	53
						3.00	III	5	<b>C6145</b>	53
24.4	11800	(1340)	29.4	9800	(1110)	1.37	I	5	<b>B6120</b>	60
						1.32	I	5	<b>B6125</b>	60
						2.65	III	5	<b>C6140</b>	60
						2.65	III	5	<b>C6145</b>	60
19.7	14600	(1650)	23.8	12100	(1370)	1.07	I	5	<b>B6120</b>	74
						1.07	I	5	<b>B6125</b>	74
						2.14	III	5	<b>C6140</b>	74
						2.14	III	5	<b>C6145</b>	74
16.6	17400	(1970)	20.0	14400	(1630)	0.83	-	5	<b>B6120</b>	88
						0.90	-	5	<b>B6125</b>	88
						1.80	II	5	<b>C6140</b>	88
						1.80	II	5	<b>C6145</b>	88
						2.67	III	5	<b>D6160</b>	88
						3.15	III	5	<b>D6165</b>	88
14.3	20200	(2280)	17.2	16700	(1890)	0.77	-	5	<b>B6120</b>	102
						0.78	-	5	<b>B6125</b>	102
						1.55	II	5	<b>C6140</b>	102
						1.55	II	5	<b>C6145</b>	102
						2.58	III	5	<b>D6160</b>	102
						2.72	III	5	<b>D6165</b>	102

**Notes:** [1] Variable Frequency Drive (VFD) notes (see page 3.8 for Constant Torque Speed Ranges):  
 (-) = For Inverter Operation, starting condition may require ambient temperature of 5° C or higher.  
 (a) = Both AV and non-AV motors can be used for selection.

**Notes:** [1] Variable Frequency Drive (VFD) notes (see page 3.8 for Constant Torque Speed Ranges):  
 (-) = For Inverter Operation, starting condition may require ambient temperature of 5° C or higher.  
 (a) = Both AV and non-AV motors can be used for selection.



# Single Reduction Selection Tables: Y1, Y2, Y3, Y4

**5 HP**  
(3.7 kW)

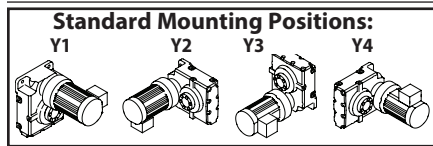

**Selection Table Pages:**  
Single Reduction  
-Y1,Y2,Y3,Y4 3.10-3.38  
-Y5,Y6 3.39-3.61  
Double Reduction  
-Y1,Y2,Y3,Y4,Y5,Y6 3.62-3.79

**Dimension Pages:**  
Single Reduction 3.80-3.85  
Double Reduction 3.86-3.91

Frequency	50 Hz	60 Hz
Input Speed	1450 RPM	1750 RPM
Number of Poles	4	

# Single Reduction Selection Tables: Y1, Y2, Y3, Y4

**7.5 HP**  
(5.5 kW)

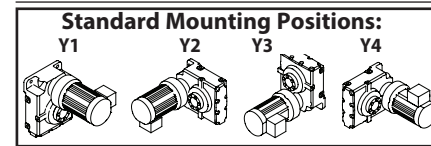

**Selection Table Pages:**  
Single Reduction  
-Y1,Y2,Y3,Y4 3.10-3.38  
-Y5,Y6 3.39-3.61  
Double Reduction  
-Y1,Y2,Y3,Y4,Y5,Y6 3.62-3.79

**Dimension Pages:**  
Single Reduction 3.80-3.85  
Double Reduction 3.86-3.91

Frequency	50 Hz	60 Hz
Input Speed	1450 RPM	1750 RPM
Number of Poles	4	

50Hz				60 Hz				Selection			VFD <sup>[1]</sup>			
Output Speed (RPM)	Output Torque		Service Factor		Output Speed (RPM)	Output Torque		Service Factor		Base				
	in-lbs	(N·m)	SF	AGMA Class		in-lbs	(N·m)	SF	AGMA Class	Motor Power Code	Frame Size	Ratio		
11.8	24400 (2750)		1.29	I	14.3	20200 (2280)		1.41	II	5	C6140	123		
			1.29	I				1.55	II	5	C6145	123		
			2.17	III				2.61	III	5	D6160	123		
			2.25	III				2.72	III	5	D6165	123		
			3.02	III				3.24	III	5	E6170	123		(-)
			3.14	III				3.79	III	5	E6175	123		(-)
			9.63	29900 (3380)					1.05	I	11.6	24800 (2800)		
1.05	I	1.26	I		5	C6145	151							
1.74	II	2.01	III		5	D6160	151							
1.83	II	2.14	III		5	D6165	151							
2.45	III	2.64	III		5	E6170	151							
2.56	III	3.05	III		5	E6175	151							
8.12	35500 (4010)		0.88		-	9.80	29400 (3320)			0.93			-	
0.88			-	1.07	I			5		C6145	179			
1.49			II	1.55	II			5		D6160	179			
1.55			II	1.87	II			5		D6165	179			
2.07			III	2.27	III			5		E6170	179			
2.16			III	2.60	III			5		E6175	179			
7.02			41100 (4640)		0.76			-		8.47	34000 (3840)		0.80	-
0.76	-	0.92			-	5	C6145	207						
1.19	I	1.19			I	5	D6160	207						
1.34	I	1.55			II	5	D6165	207						
1.79	II	1.93			II	5	E6170	207						
1.86	II	2.25			III	5	E6175	207						
5.84	49400 (5580)				0.94	-	7.04	40900 (4630)					0.94	-
1.11			I	1.34	I	5				D6165	249			
1.49			II	1.60	II	5				E6170	249			
1.55			II	1.87	II	5				E6175	249			
4.76			60600 (6840)		0.87	-				5.75	50200 (5670)		0.94	-
0.91	-	1.05			I	5	D6165	305						
1.23	I	1.30			I	5	E6170	305						
1.26	I	1.53			II	5	E6175	305						

50Hz				60 Hz				Selection			VFD <sup>[1]</sup>		
Output Speed (RPM)	Output Torque		Service Factor		Output Speed (RPM)	Output Torque		Service Factor		Base			
	in-lbs	(N·m)	SF	AGMA Class		in-lbs	(N·m)	SF	AGMA Class	Motor Power Code	Frame Size	Ratio	
138	3100 (351)		0.92	-	167	2570 (291)		0.92	-	8	B6120	11	
			1.13	I				1.06	I	8	B6125	11	
			2.28	III				2.28	III	8	C6140	11	
			2.65	III				2.65	III	8	C6145	11	
			82.9	5170 (584)					0.94	-	100	4290 (484)	
1.15	I	1.08	I		8	B6125	18						
2.36	III	2.36	III		8	C6140	18						
2.75	III	2.75	III		8	C6145	18						
69.0	6210 (701)		0.92		-	83.3	5140 (581)			0.92			-
1.27			I	1.06	I			8		B6125	21		
2.36			III	2.36	III			8		C6140	21		
2.75			III	2.75	III			8		C6145	21		
51.8			8280 (935)		0.92			-		62.5	6860 (775)		0.92
1.26	I	1.26			I	8	B6125	28					
2.36	III	2.36			III	8	C6140	28					
2.75	III	2.75			III	8	C6145	28					
37.7	11400 (1290)				0.92	-	45.5	9430 (1070)					0.92
1.08			I	1.08	I	8				B6125	39		
2.36			III	2.36	III	8				C6140	39		
2.75			III	2.75	III	8				C6145	39		
31.9			13400 (1520)		0.92	-				38.5	11100 (1260)		0.92
1.08	I	1.08			I	8	B6125	46					
2.33	III	2.36			III	8	C6140	46					
2.33	III	2.74			III	8	C6145	46					
27.6	15500 (1750)				0.92	-	33.3	12900 (1450)					0.92
1.01			I	1.08	I	8				B6125	53		
2.02			III	2.18	III	8				C6140	53		
2.02			III	2.44	III	8				C6145	53		
24.4			17600 (1990)		0.89	-				29.4	14600 (1650)		0.92
0.89	-	1.03			I	8	B6125	60					
1.78	II	1.83			II	8	C6140	60					
1.78	II	2.15			III	8	C6145	60					
2.37	III	2.37			III	8	D6160	60					
3.12	III	3.43			III	8	D6165	60					

**Notes:** [1] Variable Frequency Drive (VFD) notes (see page 3.8 for Constant Torque Speed Ranges):  
(-) = For Inverter Operation, starting condition may require ambient temperature of 5° C or higher.  
(a) = Both AV and non-AV motors can be used for selection.

**Notes:** [1] Variable Frequency Drive (VFD) notes (see page 3.8 for Constant Torque Speed Ranges):  
(-) = For Inverter Operation, starting condition may require ambient temperature of 5° C or higher.  
(a) = Both AV and non-AV motors can be used for selection.

# Single Reduction Selection Tables: Y1, Y2, Y3, Y4

**7.5 HP  
(5.5 kW)**

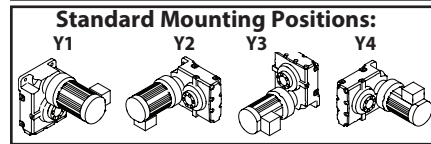

**Selection Table Pages:**

Single Reduction -Y1,Y2,Y3,Y4	3.10-3.38
-Y5,Y6	3.39-3.61
Double Reduction -Y1,Y2,Y3,Y4,Y5,Y6	3.62-3.79

**Dimension Pages:**

Single Reduction	3.80-3.85
Double Reduction	3.86-3.91

Frequency	50 Hz	60 Hz
Input Speed	1450 RPM	1750 RPM
Number of Poles	4	

50Hz			60 Hz			Selection			VFD <sup>[1]</sup>
Output Speed (RPM)	Output Torque in-lbs (N·m)	Service Factor SF AGMA Class	Output Speed (RPM)	Output Torque in-lbs (N·m)	Service Factor SF AGMA Class	Motor Power Code	Base Frame Size	Ratio	
19.7	21700 (2450)	0.72 -	23.8	18000 (2030)	0.87 -	8	<b>B6125</b>	74	
		1.44 II			1.57 II	8	<b>C6140</b>	74	
		1.44 II			1.74 II	8	<b>C6145</b>	74	
		2.35 III			2.35 III	8	<b>D6160</b>	74	
		2.53 III			2.92 III	8	<b>D6165</b>	74	
16.6	25900 (2920)	1.21 I	20.0	21400 (2420)	1.25 I	8	<b>C6140</b>	88	
		1.21 I			1.44 II	8	<b>C6145</b>	88	
		1.79 II			1.79 II	8	<b>D6160</b>	88	
		2.12 III			2.56 III	8	<b>D6165</b>	88	
		2.83 III			2.87 III	8	<b>E6170</b>	88	
2.96 III	3.57 III	8	<b>E6175</b>	88					
14.3	30000 (3390)	1.04 I	17.2	24900 (2810)	1.08 I	8	<b>C6140</b>	102	
		1.04 I			1.26 I	8	<b>C6145</b>	102	
		1.74 II			1.91 II	8	<b>D6160</b>	102	
		1.83 II			2.08 III	8	<b>D6165</b>	102	
		2.45 III			2.60 III	8	<b>E6170</b>	102	
2.55 III	3.08 III	8	<b>E6175</b>	102					
11.8	36200 (4090)	0.87 -	14.3	30000 (3390)	0.95 -	8	<b>C6140</b>	123	
		0.87 -			1.04 I	8	<b>C6145</b>	123	
		1.46 II			1.76 II	8	<b>D6160</b>	123	
		1.52 II			1.83 II	8	<b>D6165</b>	123	
		2.03 III			2.18 III	8	<b>E6170</b>	123	
2.11 III	2.55 III	8	<b>E6175</b>	123					
9.63	44500 (5030)	0.70 -	11.6	36900 (4160)	0.85 -	8	<b>C6145</b>	151	
		1.17 I			1.35 I	8	<b>D6160</b>	151	
		1.23 I			1.44 II	8	<b>D6165</b>	151	
		1.65 II			1.77 II	8	<b>E6170</b>	151	
		1.72 II			2.05 III	8	<b>E6175</b>	151	
8.12	52800 (5960)	1.00 I	9.80	43700 (4940)	1.05 I	8	<b>D6160</b>	179	
		1.04 I			1.25 I	8	<b>D6165</b>	179	
		1.39 I			1.53 II	8	<b>E6170</b>	179	
		1.45 II			1.75 II	8	<b>E6175</b>	179	
7.02	61000 (6900)	0.80 -	8.47	50600 (5710)	0.80 -	8	<b>D6160</b>	207	
		0.90 -			1.05 I	8	<b>D6165</b>	207	
		1.20 I			1.30 I	8	<b>E6170</b>	207	
		1.25 I			1.51 II	8	<b>E6175</b>	207	

**Notes:** [1] Variable Frequency Drive (VFD) notes (see page 3.8 for Constant Torque Speed Ranges):  
 (-) = For Inverter Operation, starting condition may require ambient temperature of 5° C or higher.  
 (a) = Both AV and non-AV motors can be used for selection.

# Single Reduction Selection Tables: Y1, Y2, Y3, Y4

**7.5 HP  
(5.5 kW)**

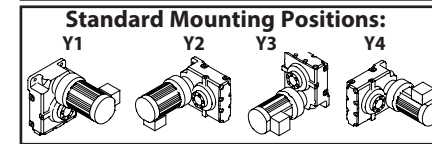

**Selection Table Pages:**

Single Reduction -Y1,Y2,Y3,Y4	3.10-3.38
-Y5,Y6	3.39-3.61
Double Reduction -Y1,Y2,Y3,Y4,Y5,Y6	3.62-3.79

**Dimension Pages:**

Single Reduction	3.80-3.85
Double Reduction	3.86-3.91

Frequency	50 Hz	60 Hz
Input Speed	1450 RPM	1750 RPM
Number of Poles	4	

50Hz			60 Hz			Selection			VFD <sup>[1]</sup>
Output Speed (RPM)	Output Torque in-lbs (N·m)	Service Factor SF AGMA Class	Output Speed (RPM)	Output Torque in-lbs (N·m)	Service Factor SF AGMA Class	Motor Power Code	Base Frame Size	Ratio	
5.84	73500 (8300)	0.75 -	7.04	60900 (6880)	0.90 -	8	<b>D6165</b>	249	
		1.00 I			1.08 I	8	<b>E6170</b>	249	
		1.04 I			1.26 I	8	<b>E6175</b>	249	
		0.83 -			0.87 -	8	<b>E6170</b>	305	
4.76	90000 (10200)	0.85 -	5.75	74600 (8430)	1.03 I	8	<b>E6175</b>	305	

**Notes:** [1] Variable Frequency Drive (VFD) notes (see page 3.8 for Constant Torque Speed Ranges):  
 (-) = For Inverter Operation, starting condition may require ambient temperature of 5° C or higher.  
 (a) = Both AV and non-AV motors can be used for selection.



# Single Reduction Selection Tables: Y1, Y2, Y3, Y4

**15 HP**  
(11 kW)

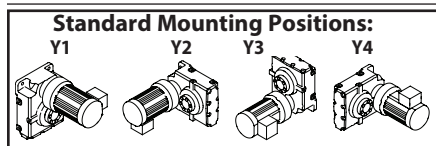

**Selection Table Pages:**  
Single Reduction -Y1,Y2,Y3,Y4 3.10-3.38  
-Y5,Y6 3.39-3.61  
Double Reduction -Y1,Y2,Y3,Y4,Y5,Y6 3.62-3.79

**Dimension Pages:**  
Single Reduction 3.80-3.85  
Double Reduction 3.86-3.91

Frequency	50 Hz	60 Hz
Input Speed	1450 RPM	1750 RPM
Number of Poles	4	

50Hz				60 Hz				Selection			VFD <sup>[1]</sup>
Output Speed (RPM)	Output Torque in-lbs (N·m)	Service Factor SF	AGMA Class	Output Speed (RPM)	Output Torque in-lbs (N·m)	Service Factor SF	AGMA Class	Motor Power Code	Frame Size	Ratio	
138	6210 (701)	1.14	I	167	5140 (581)	1.14	I	15	<b>C6140</b>	11	
		1.32	I			15	<b>C6145</b>	11			
		1.80	II			15	<b>D6160</b>	11			
		2.08	III			15	<b>D6165</b>	11			
		2.45	III			15	<b>E6170</b>	11			
		2.67	III			15	<b>E6175</b>	11			
82.9	10300 (1170)	1.18	I	100	8570 (969)	1.18	I	15	<b>C6140</b>	18	
		1.37	I			15	<b>C6145</b>	18			
		1.83	II			15	<b>D6160</b>	18			
		2.12	III			15	<b>D6165</b>	18			
		2.51	III			15	<b>E6170</b>	18			
		2.73	III			15	<b>E6175</b>	18			
69.0	12400 (1400)	1.18	I	83.3	10300 (1160)	1.18	I	15	<b>C6140</b>	21	
		1.37	I			15	<b>C6145</b>	21			
51.8	16600 (1870)	1.18	I	62.5	13700 (1550)	1.18	I	15	<b>C6140</b>	28	
		1.37	I			15	<b>C6145</b>	28			
		1.79	II			15	<b>D6160</b>	28			
		2.19	III			15	<b>D6165</b>	28			
37.7	22800 (2570)	1.18	I	45.5	18900 (2130)	1.18	I	15	<b>C6140</b>	39	
		1.37	I			15	<b>C6145</b>	39			
		1.79	II			15	<b>D6160</b>	39			
		2.19	III			15	<b>D6165</b>	39			
		2.51	III			15	<b>E6170</b>	39			
		2.74	III			15	<b>E6175</b>	39			
31.9	26900 (3040)	1.16	I	38.5	22300 (2520)	1.18	I	15	<b>C6140</b>	46	
		1.16	I			15	<b>C6145</b>	46			
		1.79	II			15	<b>D6160</b>	46			
		2.04	III			15	<b>D6165</b>	46			
		2.48	III			15	<b>E6170</b>	46			
		2.74	III			15	<b>E6175</b>	46			
27.6	31000 (3510)	1.01	I	33.3	25700 (2910)	1.09	I	15	<b>C6140</b>	53	
		1.01	I			15	<b>C6145</b>	53			
		1.70	II			15	<b>D6160</b>	53			
		1.77	II			15	<b>D6165</b>	53			
		2.32	III			15	<b>E6170</b>	53			
		2.47	III			15	<b>E6175</b>	53			

**Notes:** [1] Variable Frequency Drive (VFD) notes (see page 3.8 for Constant Torque Speed Ranges):  
 (-) = For Inverter Operation, starting condition may require ambient temperature of 5° C or higher.  
 (a) = Both AV and non-AV motors can be used for selection.

# Single Reduction Selection Tables: Y1, Y2, Y3, Y4

**15 HP**  
(11 kW)

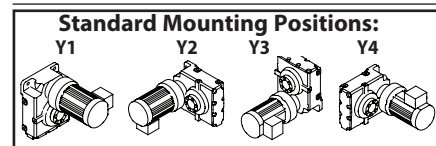

**Selection Table Pages:**  
Single Reduction -Y1,Y2,Y3,Y4 3.10-3.38  
-Y5,Y6 3.39-3.61  
Double Reduction -Y1,Y2,Y3,Y4,Y5,Y6 3.62-3.79

**Dimension Pages:**  
Single Reduction 3.80-3.85  
Double Reduction 3.86-3.91

Frequency	50 Hz	60 Hz
Input Speed	1450 RPM	1750 RPM
Number of Poles	4	

50Hz				60 Hz				Selection			VFD <sup>[1]</sup>
Output Speed (RPM)	Output Torque in-lbs (N·m)	Service Factor SF	AGMA Class	Output Speed (RPM)	Output Torque in-lbs (N·m)	Service Factor SF	AGMA Class	Motor Power Code	Frame Size	Ratio	
24.4	35200 (3970)	0.89	-	29.4	29100 (3290)	0.92	-	15	<b>C6140</b>	60	
		0.89	-			15	<b>C6145</b>	60			
		1.19	I			15	<b>D6160</b>	60			
		1.56	II			15	<b>D6165</b>	60			
		1.79	II			15	<b>E6170</b>	60			
		2.18	III			15	<b>E6175</b>	60			
19.7	43500 (4910)	0.72	-	23.8	36000 (4070)	0.87	-	15	<b>C6145</b>	74	
		1.17	I			15	<b>D6160</b>	74			
		1.26	I			15	<b>D6165</b>	74			
		1.69	II			15	<b>E6170</b>	74			
		1.76	II			15	<b>E6175</b>	74			
16.6	51700 (5840)	0.90	-	20.0	42900 (4840)	0.90	-	15	<b>D6160</b>	88	
		1.06	I			15	<b>D6165</b>	88			
		1.42	II			15	<b>E6170</b>	88			
		1.48	II			15	<b>E6175</b>	88			
14.3	60000 (6780)	0.87	-	17.2	49700 (5620)	0.95	-	15	<b>D6160</b>	102	
		0.91	-			15	<b>D6165</b>	102			
		1.22	I			15	<b>E6170</b>	102			
		1.28	I			15	<b>E6175</b>	102			
11.8	72400 (8180)	0.73	-	14.3	60000 (6780)	0.88	-	15	<b>D6160</b>	123	
		0.76	-			15	<b>D6165</b>	123			
		1.01	I			15	<b>E6170</b>	123			
		1.06	I			15	<b>E6175</b>	123			
		0.83	-			15	<b>E6170</b>	151			
0.86	-	15	<b>E6175</b>	151							
8.12	106000 (11900)	0.73	-	9.80	87400 (9880)	0.88	-	15	<b>E6175</b>	179	

**Notes:** [1] Variable Frequency Drive (VFD) notes (see page 3.8 for Constant Torque Speed Ranges):  
 (-) = For Inverter Operation, starting condition may require ambient temperature of 5° C or higher.  
 (a) = Both AV and non-AV motors can be used for selection.

Selection Tables

Selection Tables

# Single Reduction Selection Tables: Y1, Y2, Y3, Y4

**20 HP  
(15 kW)**

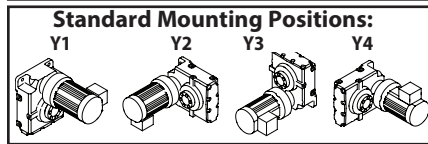

**Selection Table Pages:**

Single Reduction -Y1,Y2,Y3,Y4	3.10-3.38
-Y5,Y6	3.39-3.61
Double Reduction -Y1,Y2,Y3,Y4,Y5,Y6	3.62-3.79

**Dimension Pages:**

Single Reduction	3.80-3.85
Double Reduction	3.86-3.91

Frequency	50 Hz	60 Hz
Input Speed	1450 RPM	1750 RPM
Number of Poles	4	

50Hz			60 Hz			Selection			VFD <sup>[1]</sup>
Output Speed (RPM)	Output Torque in-lbs (N·m)	Service Factor SF AGMA Class	Output Speed (RPM)	Output Torque in-lbs (N·m)	Service Factor SF AGMA Class	Base Motor Power Code Frame Size Ratio			
138	8470 (956)	0.84 -	167	7010 (792)	0.84 -	20 C6140 11			
		0.97 -			20 C6145 11				
		1.32 I			20 D6160 11				
		1.52 II			20 D6165 11				
		1.80 II			20 E6170 11				
		1.96 II			20 E6175 11				
82.9	14100 (1590)	0.87 -	100	11700 (1320)	0.87 -	20 C6140 18			
		1.01 I			20 C6145 18				
		1.35 I			20 D6160 18				
		1.55 II			20 D6165 18				
		1.84 II			20 E6170 18				
		2.00 III			20 E6175 18				
69.0	16900 (1910)	0.87 -	83.3	14000 (1580)	0.87 -	20 C6140 21			
		1.01 I			20 C6145 21				
51.8	22600 (2550)	0.87 -	62.5	18700 (2110)	0.87 -	20 C6140 28			
		1.01 I			20 C6145 28				
		1.31 I			20 D6160 28				
		1.60 II			20 D6165 28				
37.7	31000 (3510)	0.87 -	45.5	25700 (2910)	0.87 -	20 C6140 39			
		1.01 I			20 C6145 39				
		1.31 I			20 D6160 39				
		1.60 II			20 D6165 39				
		1.84 II			20 E6170 39				
		2.01 III			20 E6175 39				
31.9	36700 (4140)	0.85 -	38.5	30400 (3430)	0.87 -	20 C6140 46			
		0.85 -			20 C6145 46				
		1.31 I			20 D6160 46				
		1.50 II			20 D6165 46				
		1.82 II			20 E6170 46				
		2.01 III			20 E6175 46				
27.6	42300 (4780)	0.74 -	33.3	35100 (3960)	0.80 -	20 C6140 53			
		0.74 -			20 C6145 53				
		1.25 I			20 D6160 53				
		1.30 I			20 D6165 53				
		1.70 II			20 E6170 53				
		1.81 II			20 E6175 53				

**Notes:** [1] Variable Frequency Drive (VFD) notes (see page 3.8 for Constant Torque Speed Ranges):  
 (-) = For Inverter Operation, starting condition may require ambient temperature of 5° C or higher.  
 (a) = Both AV and non-AV motors can be used for selection.

# Single Reduction Selection Tables: Y1, Y2, Y3, Y4

**20 HP  
(15 kW)**

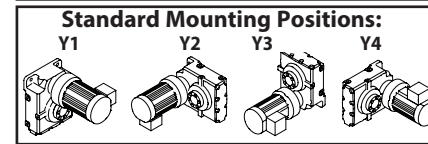

**Selection Table Pages:**

Single Reduction -Y1,Y2,Y3,Y4	3.10-3.38
-Y5,Y6	3.39-3.61
Double Reduction -Y1,Y2,Y3,Y4,Y5,Y6	3.62-3.79

**Dimension Pages:**

Single Reduction	3.80-3.85
Double Reduction	3.86-3.91

Frequency	50 Hz	60 Hz
Input Speed	1450 RPM	1750 RPM
Number of Poles	4	

50Hz			60 Hz			Selection			VFD <sup>[1]</sup>
Output Speed (RPM)	Output Torque in-lbs (N·m)	Service Factor SF AGMA Class	Output Speed (RPM)	Output Torque in-lbs (N·m)	Service Factor SF AGMA Class	Base Motor Power Code Frame Size Ratio			
24.4	48000 (5420)	0.87 -	29.4	39700 (4490)	0.87 -	20 D6160 60			
		1.14 I			20 D6165 60				
		1.31 I			20 E6170 60				
		1.60 II			20 E6175 60				
		19.7			59300 (6690)	0.86 -		23.8	49100 (5550)
0.93 -	20 D6165 74								
1.24 I	20 E6170 74								
1.29 I	20 E6175 74								
16.6	70500 (7970)	0.78 -	20.0	58400 (6600)	0.94 -	20 D6165 88			
		1.04 I			20 E6170 88				
		1.09 I			20 E6175 88				
		14.3			81800 (9250)	0.90 -		17.2	67800 (7660)
0.94 -	20 E6175 102								
11.8	98800 (11200)	0.74 -	14.3	81800 (9250)	0.80 -	20 E6170 123			
		0.78 -			20 E6175 123				

**Notes:** [1] Variable Frequency Drive (VFD) notes (see page 3.8 for Constant Torque Speed Ranges):  
 (-) = For Inverter Operation, starting condition may require ambient temperature of 5° C or higher.  
 (a) = Both AV and non-AV motors can be used for selection.

# Single Reduction Selection Tables: Y1, Y2, Y3, Y4

**25 HP**  
(18.5 kW)

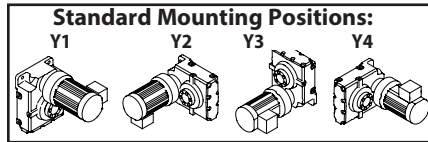

**Selection Table Pages:**

Single Reduction -Y1,Y2,Y3,Y4	3.10-3.38
-Y5,Y6	3.39-3.61
Double Reduction -Y1,Y2,Y3,Y4,Y5,Y6	3.62-3.79

**Dimension Pages:**

Single Reduction	3.80-3.85
Double Reduction	3.86-3.91

Frequency	50 Hz	60 Hz
Input Speed	1450 RPM	1750 RPM
Number of Poles	4	

50Hz			60 Hz			Selection							
Output Speed (RPM)	Output Torque		Service Factor		Output Speed (RPM)	Output Torque		Service Factor		Base			VFD <sup>[1]</sup>
	in-lbs	(N·m)	SF	AGMA Class		in-lbs	(N·m)	SF	AGMA Class	Motor Power Code	Frame Size	Ratio	
138	10400 (1180)		1.07	I	167	8650 (977)		1.07	I	25	D6160	11	
			1.24	I				25	D6165	11			
			1.46	II				25	E6170	11			
			1.59	II				25	E6175	11			
82.9	17400 (1970)		1.09	I	100	14400 (1630)		1.09	I	25	D6160	18	
			1.26	I				25	D6165	18			
			1.49	II				25	E6170	18			
			1.63	II				25	E6175	18			
51.8	27800 (3150)		1.06	I	62.5	23100 (2610)		1.06	I	25	D6160	28	
			1.30	I				25	D6165	28			
37.7	38300 (4330)		1.06	I	45.5	31700 (3580)		1.06	I	25	D6160	39	
			1.30	I				25	D6165	39			
			1.49	II				25	E6170	39			
			1.63	II				25	E6175	39			
31.9	45200 (5110)		1.06	I	38.5	37500 (4240)		1.06	I	25	D6160	46	
			1.21	I				25	D6165	46			
			1.47	II				25	E6170	46			
			1.63	II				25	E6175	46			
27.6	52200 (5900)		1.01	I	33.3	43300 (4890)		1.01	I	25	D6160	53	
			1.05	I				25	D6165	53			
			1.38	I				25	E6170	53			
			1.47	II				25	E6175	53			
24.4	59200 (6680)		0.93	-	29.4	49000 (5540)		1.02	I	25	D6165	60	
			1.06	I				25	E6170	60			
			1.29	I				25	E6175	60			
19.7	73100 (8260)		0.75	-	23.8	60600 (6840)		0.87	-	25	D6165	74	
			1.00	I				25	E6170	74			
			1.05	I				25	E6175	74			
16.6	87000 (9830)		0.84	-	20.0	72100 (8140)		0.85	-	25	E6170	88	
			0.88	-				25	E6175	88			
14.3	101000 (11400)		0.76	-	17.2	83600 (9450)		0.92	-	25	E6175	102	

**Notes: [1]** Variable Frequency Drive (VFD) notes (see page 3.8 for Constant Torque Speed Ranges):  
 (-) = For Inverter Operation, starting condition may require ambient temperature of 5° C or higher.  
 (a) = Both AV and non-AV motors can be used for selection.

# Single Reduction Selection Tables: Y1, Y2, Y3, Y4

**30 HP**  
(22 kW)

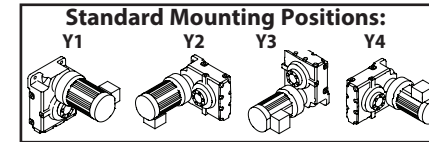

**Selection Table Pages:**

Single Reduction -Y1,Y2,Y3,Y4	3.10-3.38
-Y5,Y6	3.39-3.61
Double Reduction -Y1,Y2,Y3,Y4,Y5,Y6	3.62-3.79

**Dimension Pages:**

Single Reduction	3.80-3.85
Double Reduction	3.86-3.91

Frequency	50 Hz	60 Hz
Input Speed	1450 RPM	1750 RPM
Number of Poles	4	

50Hz			60 Hz			Selection							
Output Speed (RPM)	Output Torque		Service Factor		Output Speed (RPM)	Output Torque		Service Factor		Base			VFD <sup>[1]</sup>
	in-lbs	(N·m)	SF	AGMA Class		in-lbs	(N·m)	SF	AGMA Class	Motor Power Code	Frame Size	Ratio	
138	12400 (1400)		0.90	-	167	10300 (1160)		0.90	-	30	D6160	11	
			1.04	I				30	D6165	11			
			1.22	I				30	E6170	11			
			1.34	I				30	E6175	11			
82.9	20700 (2340)		0.92	-	100	17100 (1940)		0.92	-	30	D6160	18	
			1.06	I				30	D6165	18			
			1.25	I				30	E6170	18			
			1.37	I				30	E6175	18			
51.8	33100 (3740)		0.90	-	62.5	27400 (3100)		0.90	-	30	D6160	28	
			1.09	I				30	D6165	28			
37.7	45500 (5140)		0.90	-	45.5	37700 (4260)		0.90	-	30	D6160	39	
			1.09	I				30	D6165	39			
			1.25	I				30	E6170	39			
			1.37	I				30	E6175	39			
31.9	53800 (6080)		0.90	-	38.5	44600 (5040)		0.90	-	30	D6160	46	
			1.02	I				30	D6165	46			
			1.24	I				30	E6170	46			
			1.37	I				30	E6175	46			
27.6	62100 (7010)		0.85	-	33.3	51400 (5810)		0.85	-	30	D6160	53	
			0.88	-				30	D6165	53			
			1.16	I				30	E6170	53			
			1.23	I				30	E6175	53			
24.4	70400 (7950)		0.78	-	29.4	58300 (6590)		0.86	-	30	D6165	60	
			0.89	-				30	E6170	60			
			1.09	I				30	E6175	60			
19.7	86900 (9820)		0.84	-	23.8	72000 (8140)		0.89	-	30	E6170	74	
			0.88	-				30	E6175	74			
16.6	103000 (11700)		0.74	-	20.0	85700 (9690)		0.89	-	30	E6175	88	

**Notes: [1]** Variable Frequency Drive (VFD) notes (see page 3.8 for Constant Torque Speed Ranges):  
 (-) = For Inverter Operation, starting condition may require ambient temperature of 5° C or higher.  
 (a) = Both AV and non-AV motors can be used for selection.

# Single Reduction Selection Tables: Y1, Y2, Y3, Y4

**40 HP  
(30 kW)**

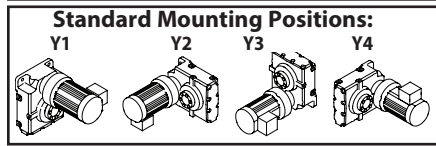

**Selection Table Pages:**

Single Reduction	
-Y1,Y2,Y3,Y4	3.10-3.38
-Y5,Y6	3.39-3.61
Double Reduction	
-Y1,Y2,Y3,Y4,Y5,Y6	3.62-3.79

**Dimension Pages:**

Single Reduction	3.80-3.85
Double Reduction	3.86-3.91

Frequency	50 Hz	60 Hz
Input Speed	1450 RPM	1750 RPM
Number of Poles	4	

50Hz				60 Hz				Selection					
Output Speed (RPM)	Output Torque		Service Factor		Output Speed (RPM)	Output Torque		Service Factor		Base			VFD <sup>[1]</sup>
	in-lbs	(N·m)	SF	AGMA Class		in-lbs	(N·m)	SF	AGMA Class	Motor Power Code	Frame Size	Ratio	
138	16900	(1910)	0.90	-	167	14000	(1580)	0.90	-	40	<b>E6170</b>	11	
			0.98	-				40	<b>E6175</b>	11			
82.9	28200	(3190)	0.92	-	100	23400	(2640)	0.92	-	40	<b>E6170</b>	18	
			1.00	I				40	<b>E6175</b>	18			
			1.00	I				40	<b>E6175</b>	18			
37.7	62100	(7010)	0.92	-	45.5	51400	(5810)	0.92	-	40	<b>E6170</b>	39	
			1.00	I				40	<b>E6175</b>	39			
31.9	73400	(8290)	0.91	-	38.5	60800	(6870)	0.91	-	40	<b>E6170</b>	46	
			1.00	I				40	<b>E6175</b>	46			
27.6	84700	(9560)	0.85	-	33.3	70100	(7920)	0.85	-	40	<b>E6170</b>	53	
			0.90	-				40	<b>E6175</b>	53			
24.4	95900	(10800)	0.80	-	29.4	79500	(8980)	0.80	-	40	<b>E6175</b>	60	

# Single Reduction Selection Tables: Y5, Y6

**1/8 HP  
(0.1 kW)**

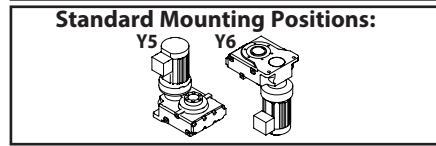

**Selection Table Pages:**

Single Reduction	
-Y1,Y2,Y3,Y4	3.10-3.38
-Y5,Y6	3.39-3.60
Double Reduction	
-Y1,Y2,Y3,Y4,Y5,Y6	3.62-3.79

**Dimension Pages:**

Single Reduction	3.80-3.85
Double Reduction	3.86-3.91

Frequency	50 Hz	60 Hz
Input Speed	1450 RPM	1750 RPM
Number of Poles	4	

50Hz				60 Hz				Selection					
Output Speed (RPM)	Output Torque		Service Factor		Output Speed (RPM)	Output Torque		Service Factor		Base			VFD <sup>[1]</sup>
	in-lbs	(N·m)	SF	AGMA Class		in-lbs	(N·m)	SF	AGMA Class	Motor Power Code	Frame Size	Ratio	
7.02	1110	(125)	3.09	III	8.47	920	(104)	3.09	III	01	<b>Z6090</b>	207	(a)
5.84	1340	(151)	2.52	III	7.04	1110	(125)	2.52	III	01	<b>Z6090</b>	249	(a)
			2.78	III				01	<b>Z6095</b>	249	(a)		
4.76	1640	(185)	2.11	III	5.75	1360	(153)	2.11	III	01	<b>Z6090</b>	305	(a)
			2.39	III				01	<b>Z6095</b>	305	(a)		
3.48	2240	(253)	1.25	I	4.20	1850	(210)	1.25	I	01	<b>Z6090</b>	417	(a)
			1.45	II				01	<b>Z6095</b>	417	(a)		

**Notes:** [1] Variable Frequency Drive (VFD) notes (see page 3.8 for Constant Torque Speed Ranges):  
 (-) = For Inverter Operation, starting condition may require ambient temperature of 5° C or higher.  
 (a) = Both AV and non-AV motors can be used for selection.

**Notes:** [1] Variable Frequency Drive (VFD) notes (see page 3.8 for Constant Torque Speed Ranges):

# Single Reduction Selection Tables: Y5, Y6

**1/4 HP  
(0.2 kW)**

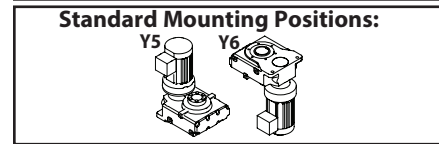

**Selection Table Pages:**  
Single Reduction -Y1,Y2,Y3,Y4 3.10-3.38  
-Y5,Y6 3.39-3.60  
Double Reduction -Y1,Y2,Y3,Y4,Y5,Y6 3.62-3.79

**Dimension Pages:**  
Single Reduction 3.80-3.85  
Double Reduction 3.86-3.91

Frequency	50 Hz	60 Hz
Input Speed	1450 RPM	1750 RPM
Number of Poles	4	

50Hz			60 Hz			Selection							
Output Speed (RPM)	Output Torque		Service Factor		Output Speed (RPM)	Output Torque		Service Factor		Base			VFD <sup>[1]</sup>
	in-lbs	(N·m)	SF	AGMA Class		in-lbs	(N·m)	SF	AGMA Class	Motor Power Code	Frame Size	Ratio	
14.3	1090	(123)	3.13	III	17.2	904	(102)	3.13	III	02	Z6090	102	(a)
11.8	1320	(149)	2.97	III	14.3	1090	(123)	3.06	III	02	Z6090	123	(a)
			2.97	III				3.58	III				
9.63	1620	(183)	2.18	III	11.6	1340	(151)	2.18	III	02	Z6090	151	(a)
			2.41	III				2.91	III				
8.12	1920	(217)	1.66	II	9.80	1590	(180)	1.66	II	02	Z6090	179	(a)
			2.04	III				2.11	III				
			2.80	III				2.80	III				
7.02	2220	(251)	1.54	II	8.47	1840	(208)	1.54	II	02	Z6090	207	(a)
			1.68	II				1.86	II				
			2.58	III				2.58	III				
5.84	2670	(302)	1.26	I	7.04	2210	(250)	1.26	I	02	Z6090	249	(a)
			1.39	I				1.51	II				
			2.18	III				2.18	III				
			2.53	III				2.81	III				
									2.81				
4.76	3270	(370)	1.06	I	5.75	2710	(306)	1.06	I	02	Z6090	305	(a)
			1.19	I				1.44	II				
			2.17	III				2.17	III				
			2.39	III				2.83	III				
3.48	4480	(506)	1.05	I	4.20	3710	(419)	1.05	I	02	A6100	417	(a)
			1.43	II				1.43	II				

# Single Reduction Selection Tables: Y5, Y6

**1/3 HP  
(0.25 kW)**

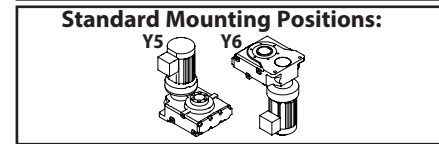

**Selection Table Pages:**  
Single Reduction -Y1,Y2,Y3,Y4 3.10-3.38  
-Y5,Y6 3.39-3.60  
Double Reduction -Y1,Y2,Y3,Y4,Y5,Y6 3.62-3.79

**Dimension Pages:**  
Single Reduction 3.80-3.85  
Double Reduction 3.86-3.91

Frequency	50 Hz	60 Hz
Input Speed	1450 RPM	1750 RPM
Number of Poles	4	

50Hz			60 Hz			Selection							
Output Speed (RPM)	Output Torque		Service Factor		Output Speed (RPM)	Output Torque		Service Factor		Base			VFD <sup>[1]</sup>
	in-lbs	(N·m)	SF	AGMA Class		in-lbs	(N·m)	SF	AGMA Class	Motor Power Code	Frame Size	Ratio	
19.7	988	(112)	3.03	III	23.8	818	(92.5)	3.03	III	03	Z6090	74	(a)
16.6	1180	(133)	2.68	III	20.0	974	(110)	2.68	III	03	Z6090	88	(a)
14.3	1360	(154)	2.50	III	17.2	1130	(128)	2.50	III	03	Z6090	102	(a)
			2.86	III				3.13	III				
11.8	1650	(186)	2.37	III	14.3	1360	(154)	2.45	III	03	Z6090	123	(a)
			2.37	III				2.86	III				
9.63	2020	(228)	1.74	II	11.6	1680	(189)	1.74	II	03	Z6090	151	(a)
			1.93	II				2.33	III				
			3.12	III				3.12	III				
8.12	2400	(271)	1.33	I	9.80	1990	(225)	1.33	I	03	Z6090	179	(a)
			1.63	II				1.69	II				
			2.24	III				2.24	III				
			3.10	III				3.10	III				
7.02	2770	(313)	1.24	I	8.47	2300	(260)	1.24	I	03	Z6090	207	(a)
			1.34	I				1.49	II				
			2.06	III				2.06	III				
			2.72	III				2.83	III				
5.84	3340	(377)	1.01	I	7.04	2770	(313)	1.01	I	03	Z6090	249	(a)
			1.11	I				1.21	I				
			1.74	II				1.74	II				
			2.02	III				2.24	III				
4.76	4090	(462)	0.85	-	5.75	3390	(383)	0.85	-	03	Z6090	305	(a)
			0.95	-				1.15	I				
			1.73	II				1.73	II				
			1.91	II				2.26	III				
3.48	5600	(632)	0.84	-	4.20	4640	(524)	0.84	-	03	A6100	417	(a)
			1.14	I				1.14	I				

Notes: [1] Variable Frequency Drive (VFD) notes (see page 3.8 for Constant Torque Speed Ranges):

Notes: [1] Variable Frequency Drive (VFD) notes (see page 3.8 for Constant Torque Speed Ranges):





# Single Reduction Selection Tables: Y5, Y6

**3/4 HP  
(0.55 kW)**

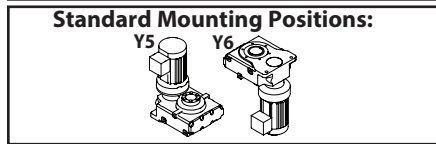

**Selection Table Pages:**

Single Reduction	
-Y1,Y2,Y3,Y4	3.10-3.38
-Y5,Y6	3.39-3.60
Double Reduction	
-Y1,Y2,Y3,Y4,Y5,Y6	3.62-3.79

**Dimension Pages:**

Single Reduction	3.80-3.85
Double Reduction	3.86-3.91

Frequency	50 Hz	60 Hz
Input Speed	1450 RPM	1750 RPM
Number of Poles	4	

50Hz				60 Hz				Selection					
Output Speed (RPM)	Output Torque		Service Factor		Output Speed (RPM)	Output Torque		Service Factor		Base			VFD <sup>[1]</sup>
	in-lbs	(N·m)	SF	AGMA Class		in-lbs	(N·m)	SF	AGMA Class	Motor Power Code	Frame Size	Ratio	
5.84	7350	(830)	0.92	-	7.04	6090	(688)	1.02	I	08	<b>A6105</b>	249	(a)
			1.74	II				08	<b>B6120</b>	249	(a)		
			2.07	III				08	<b>B6125</b>	249	(a)		
			2.75	III				08	<b>C6145</b>	249	(a)		
4.76	9000	(1020)	0.87	-	5.75	7460	(843)	1.03	I	08	<b>A6105</b>	305	(a)
			1.72	II				08	<b>B6120</b>	305	(a)		
			1.74	II				08	<b>B6125</b>	305	(a)		
			2.75	III				08	<b>C6145</b>	305	(a)		

# Single Reduction Selection Tables: Y5, Y6

**1 HP  
(0.75 kW)**

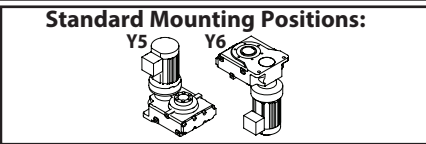

**Selection Table Pages:**

Single Reduction	
-Y1,Y2,Y3,Y4	3.10-3.38
-Y5,Y6	3.39-3.60
Double Reduction	
-Y1,Y2,Y3,Y4,Y5,Y6	3.62-3.79

**Dimension Pages:**

Single Reduction	3.80-3.85
Double Reduction	3.86-3.91

Frequency	50 Hz	60 Hz
Input Speed	1450 RPM	1750 RPM
Number of Poles	4	

50Hz				60 Hz				Selection					
Output Speed (RPM)	Output Torque		Service Factor		Output Speed (RPM)	Output Torque		Service Factor		Base			VFD <sup>[1]</sup>
	in-lbs	(N·m)	SF	AGMA Class		in-lbs	(N·m)	SF	AGMA Class	Motor Power Code	Frame Size	Ratio	
69.0	847	(95.6)	1.53	II	83.3	701	(79.2)	1.53	II	1	<b>Z6090</b>	21	
			2.02	III				1	<b>Z6095</b>	21			
			3.13	III				1	<b>A6100</b>	21			
51.8	1130	(128)	1.53	II	62.5	935	(106)	1.53	II	1	<b>Z6090</b>	28	
			2.02	III				1	<b>Z6095</b>	28			
			3.13	III				1	<b>A6100</b>	28			
37.7	1550	(175)	1.53	II	45.5	1290	(145)	1.53	II	1	<b>Z6090</b>	39	
			2.02	III				1	<b>Z6095</b>	39			
			3.13	III				1	<b>A6100</b>	39			
31.9	1830	(207)	1.53	II	38.5	1520	(172)	1.53	II	1	<b>Z6090</b>	46	
			2.02	III				1	<b>Z6095</b>	46			
			3.13	III				1	<b>A6100</b>	46			
27.6	2120	(239)	1.53	II	33.3	1750	(198)	1.53	II	1	<b>Z6090</b>	53	
			1.85	II				1	<b>Z6095</b>	53			
			3.13	III				1	<b>A6100</b>	53			
24.4	2400	(271)	1.53	II	29.4	1990	(225)	1.53	II	1	<b>Z6090</b>	60	
			1.63	II				1	<b>Z6095</b>	60			
			2.65	III				1	<b>A6100</b>	60			
19.7	2960	(335)	1.01	I	23.8	2450	(277)	1.01	I	1	<b>Z6090</b>	74	
			1.32	I				1	<b>Z6095</b>	74			
			2.53	III				1	<b>A6100</b>	74			
			2.64	III				1	<b>A6105</b>	74			
16.6	3530	(399)	0.89	-	20.0	2920	(330)	0.89	-	1	<b>Z6090</b>	88	
			1.11	I				1	<b>Z6095</b>	88			
			1.69	II				1	<b>A6100</b>	88			
			2.22	III				1	<b>A6105</b>	88			
14.3	4090	(462)	0.83	-	17.2	3390	(383)	0.83	-	1	<b>Z6090</b>	102	
			0.95	-				1	<b>Z6095</b>	102			
			1.61	II				1	<b>A6100</b>	102			
			1.91	II				1	<b>A6105</b>	102			
11.8	4940	(558)	0.79	-	14.3	4090	(462)	0.82	-	1	<b>Z6090</b>	123	
			0.79	-				1	<b>Z6095</b>	123			
			1.30	I				1	<b>A6100</b>	123			
			1.58	II				1	<b>A6105</b>	123			
			3.16	III				1	<b>B6120</b>	123			
			3.17	III				1	<b>B6125</b>	123			

Notes: [1] Variable Frequency Drive (VFD) notes (see page 3.8 for Constant Torque Speed Ranges):

Notes: [1] Variable Frequency Drive (VFD) notes (see page 3.8 for Constant Torque Speed Ranges):

# Single Reduction Selection Tables: Y5, Y6

**1 HP**  
(0.75 kW)

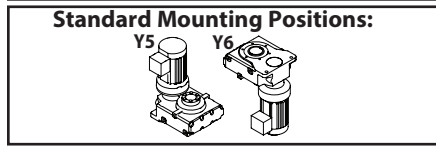

**Selection Table Pages:**

Single Reduction -Y1,Y2,Y3,Y4	3.10-3.38
-Y5,Y6	3.39-3.60
Double Reduction -Y1,Y2,Y3,Y4,Y5,Y6	3.62-3.79

**Dimension Pages:**

Single Reduction	3.80-3.85
Double Reduction	3.86-3.91

Frequency	50 Hz	60 Hz
Input Speed	1450 RPM	1750 RPM
Number of Poles	4	

50Hz				60 Hz				Selection					
Output Speed (RPM)	Output Torque		Service Factor		Output Speed (RPM)	Output Torque		Service Factor		Base			VFD <sup>[1]</sup>
	in-lbs	(N·m)	SF	AGMA Class		in-lbs	(N·m)	SF	AGMA Class	Motor Power Code	Frame Size	Ratio	
9.63	6070	(685)	1.04	I	11.6	5030	(568)	1.04	I	1	<b>A6100</b>	151	
			1.29	I				1	<b>A6105</b>	151			
			2.55	III				1	<b>B6120</b>	151			
			2.58	III				1	<b>B6125</b>	151			
8.12	7200	(813)	1.03	I	9.80	5960	(674)	1.03	I	1	<b>A6105</b>	179	
			2.17	III				1	<b>B6120</b>	179			
			2.18	III				1	<b>B6125</b>	179			
			2.96	III				1	<b>C6145</b>	179			
7.02	8320	(940)	0.91	-	8.47	6900	(779)	0.94	-	1	<b>A6105</b>	207	
			1.73	II				1	<b>B6120</b>	207			
			1.88	II				1	<b>B6125</b>	207			
			2.96	III				1	<b>C6145</b>	207			
5.84	10000	(1130)	1.28	I	7.04	8300	(938)	1.28	I	1	<b>B6120</b>	249	
			1.52	II				1	<b>B6125</b>	249			
			2.02	III				1	<b>C6145</b>	249			
			2.96	III				1	<b>D6165</b>	249			
4.76	12300	(1390)	1.26	I	5.75	10200	(1150)	1.26	I	1	<b>B6120</b>	305	
			1.28	I				1	<b>B6125</b>	305			
			2.02	III				1	<b>C6145</b>	305			
			2.96	III				1	<b>D6165</b>	305			

# Single Reduction Selection Tables: Y5, Y6

**1.5 HP**  
(1.1 kW)

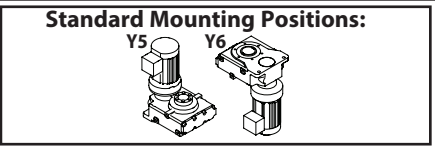

**Selection Table Pages:**

Single Reduction -Y1,Y2,Y3,Y4	3.10-3.38
-Y5,Y6	3.39-3.60
Double Reduction -Y1,Y2,Y3,Y4,Y5,Y6	3.62-3.79

**Dimension Pages:**

Single Reduction	3.80-3.85
Double Reduction	3.86-3.91

Frequency	50 Hz	60 Hz
Input Speed	1450 RPM	1750 RPM
Number of Poles	4	

50Hz				60 Hz				Selection					
Output Speed (RPM)	Output Torque		Service Factor		Output Speed (RPM)	Output Torque		Service Factor		Base			VFD <sup>[1]</sup>
	in-lbs	(N·m)	SF	AGMA Class		in-lbs	(N·m)	SF	AGMA Class	Motor Power Code	Frame Size	Ratio	
69.0	1240	(140)	1.04	I	83.3	1030	(116)	1.04	I	1H	<b>Z6090</b>	21	
			1.38	I				1H	<b>Z6095</b>	21			
			2.13	III				1H	<b>A6100</b>	21			
			2.89	III				1H	<b>A6105</b>	21			
			2.89	III				1H	<b>A6105</b>	21			
51.8	1660	(187)	1.04	I	62.5	1370	(155)	1.04	I	1H	<b>Z6090</b>	28	
			1.38	I				1H	<b>Z6095</b>	28			
			2.13	III				1H	<b>A6100</b>	28			
			2.89	III				1H	<b>A6105</b>	28			
37.7	2280	(257)	1.04	I	45.5	1890	(213)	1.04	I	1H	<b>Z6090</b>	39	
			1.38	I				1H	<b>Z6095</b>	39			
			2.13	III				1H	<b>A6100</b>	39			
			2.89	III				1H	<b>A6105</b>	39			
31.9	2690	(304)	1.04	I	38.5	2230	(252)	1.04	I	1H	<b>Z6090</b>	46	
			1.38	I				1H	<b>Z6095</b>	46			
			2.13	III				1H	<b>A6100</b>	46			
			2.89	III				1H	<b>A6105</b>	46			
27.6	3100	(351)	1.04	I	33.3	2570	(291)	1.04	I	1H	<b>Z6090</b>	53	
			1.26	I				1H	<b>Z6095</b>	53			
			2.13	III				1H	<b>A6100</b>	53			
			2.52	III				1H	<b>A6105</b>	53			
24.4	3520	(397)	1.04	I	29.4	2910	(329)	1.04	I	1H	<b>Z6090</b>	60	
			1.11	I				1H	<b>Z6095</b>	60			
			1.81	II				1H	<b>A6100</b>	60			
			2.22	III				1H	<b>A6105</b>	60			
19.7	4350	(491)	0.90	-	23.8	3600	(407)	1.08	I	1H	<b>Z6095</b>	74	
			1.73	II				1H	<b>A6100</b>	74			
			1.80	II				1H	<b>A6105</b>	74			
16.6	5170	(584)	1.15	I	20.0	4290	(484)	1.15	I	1H	<b>A6100</b>	88	
			1.51	II				1H	<b>A6105</b>	88			
			2.81	III				1H	<b>B6120</b>	88			
			3.03	III				1H	<b>B6125</b>	88			
14.3	6000	(678)	1.10	I	17.2	4970	(562)	1.10	I	1H	<b>A6100</b>	102	
			1.30	I				1H	<b>A6105</b>	102			
			2.61	III				1H	<b>B6120</b>	102			
			2.61	III				1H	<b>B6125</b>	102			

**Notes:** [1] Variable Frequency Drive (VFD) notes (see page 3.8 for Constant Torque Speed Ranges):  
All 1HP+ motors require EP suffix in model number and can be used with a VFD, unless noted.

**Notes:** [1] Variable Frequency Drive (VFD) notes (see page 3.8 for Constant Torque Speed Ranges):  
All 1HP+ motors require EP suffix in model number and can be used with a VFD, unless noted.



# Single Reduction Selection Tables: Y5, Y6

**2 HP**  
(1.5 kW)

**Standard Mounting Positions:**

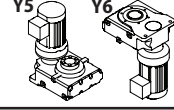

**Selection Table Pages:**

Single Reduction  
-Y1,Y2,Y3,Y4 3.10-3.38  
-Y5,Y6 3.39-3.60  
Double Reduction  
-Y1,Y2,Y3,Y4,Y5,Y6 3.62-3.79

**Dimension Pages:**

Single Reduction 3.80-3.85  
Double Reduction 3.86-3.91

Frequency	50 Hz	60 Hz
Input Speed	1450 RPM	1750 RPM
Number of Poles	4	

50Hz				60 Hz				Selection					
Output Speed (RPM)	Output Torque		Service Factor		Output Speed (RPM)	Output Torque		Service Factor		Base			VFD <sup>[1]</sup>
	in-lbs	(N·m)	SF	AGMA Class		in-lbs	(N·m)	SF	AGMA Class	Motor Power Code	Frame Size	Ratio	
9.63	12100 (1370)		1.27	I	11.6	10100 (1140)		1.27	I	2	<b>B6120</b>	151	
			1.29	I				2	<b>B6125</b>	151			
			2.49	III				2	<b>D6165</b>	151			
8.12	14400 (1630)		1.09	I	9.80	11900 (1350)		1.14	I	2	<b>B6120</b>	179	
			1.09	I				2	<b>B6125</b>	179			
			1.48	II				2	<b>C6145</b>	179			
			2.49	III				2	<b>D6165</b>	179			
7.02	16600 (1880)		0.87	-	8.47	13800 (1560)		0.87	-	2	<b>B6120</b>	207	
			0.94	-				2	<b>B6125</b>	207			
			1.48	II				2	<b>C6145</b>	207			
			2.49	III				2	<b>D6165</b>	207			
5.84	20000 (2260)		0.76	-	7.04	16600 (1880)		0.80	-	2	<b>B6125</b>	249	
			1.01	I				2	<b>C6145</b>	249			
			1.48	II				2	<b>D6165</b>	249			
4.76	24500 (2770)		1.01	I	5.75	20300 (2300)		1.01	I	2	<b>C6145</b>	305	
			1.48	II				2	<b>D6165</b>	305			

# Single Reduction Selection Tables: Y5, Y6

**3 HP**  
(2.2 kW)

**Standard Mounting Positions:**

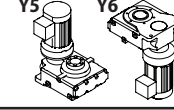

**Selection Table Pages:**

Single Reduction  
-Y1,Y2,Y3,Y4 3.10-3.38  
-Y5,Y6 3.39-3.60  
Double Reduction  
-Y1,Y2,Y3,Y4,Y5,Y6 3.62-3.79

**Dimension Pages:**

Single Reduction 3.80-3.85  
Double Reduction 3.86-3.91

Frequency	50 Hz	60 Hz
Input Speed	1450 RPM	1750 RPM
Number of Poles	4	

50Hz				60 Hz				Selection					
Output Speed (RPM)	Output Torque		Service Factor		Output Speed (RPM)	Output Torque		Service Factor		Base			VFD <sup>[1]</sup>
	in-lbs	(N·m)	SF	AGMA Class		in-lbs	(N·m)	SF	AGMA Class	Motor Power Code	Frame Size	Ratio	
69.0	2480 (281)		1.07	I	83.3	2060 (232)		1.07	I	3	<b>A6100</b>	21	
			1.45	II				3	<b>A6105</b>	21			
			2.30	III				3	<b>B6120</b>	21			
			3.16	III				3	<b>B6125</b>	21			
51.8	3310 (374)		1.07	I	62.5	2740 (310)		1.07	I	3	<b>A6100</b>	28	
			1.45	II				3	<b>A6105</b>	28			
			2.30	III				3	<b>B6120</b>	28			
			3.16	III				3	<b>B6125</b>	28			
37.7	4550 (514)		1.07	I	45.5	3770 (426)		1.07	I	3	<b>A6100</b>	39	
			1.45	II				3	<b>A6105</b>	39			
			2.30	III				3	<b>B6120</b>	39			
			2.69	III				3	<b>B6125</b>	39			
31.9	5380 (608)		1.07	I	38.5	4460 (504)		1.07	I	3	<b>A6100</b>	46	
			1.45	II				3	<b>A6105</b>	46			
			2.30	III				3	<b>B6120</b>	46			
			2.69	III				3	<b>B6125</b>	46			
27.6	6210 (701)		1.07	I	33.3	5140 (581)		1.07	I	3	<b>A6100</b>	53	
			1.26	I				3	<b>A6105</b>	53			
			2.30	III				3	<b>B6120</b>	53			
			2.52	III				3	<b>B6125</b>	53			
24.4	7040 (795)		0.90	-	29.4	5830 (659)		0.90	-	3	<b>A6100</b>	60	
			1.11	I				3	<b>A6105</b>	60			
			2.22	III				3	<b>B6120</b>	60			
			2.23	III				3	<b>B6125</b>	60			
19.7	8690 (982)		0.86	-	23.8	7200 (814)		0.88	-	3	<b>A6100</b>	74	
			0.90	-				3	<b>A6105</b>	74			
			1.80	II				3	<b>B6120</b>	74			
			1.80	II				3	<b>B6125</b>	74			
			2.53	III				3	<b>C6145</b>	74			
16.6	10300 (1170)		1.40	II	20.0	8570 (969)		1.40	II	3	<b>B6120</b>	88	
			1.51	II				3	<b>B6125</b>	88			
			2.53	III				3	<b>C6145</b>	88			
14.3	12000 (1360)		1.30	I	17.2	9940 (1120)		1.36	I	3	<b>B6120</b>	102	
			1.31	I				3	<b>B6125</b>	102			
			1.70	II				3	<b>C6145</b>	102			

**Notes:** [1] Variable Frequency Drive (VFD) notes (see page 3.8 for Constant Torque Speed Ranges):  
All 1HP+ motors require EP suffix in model number and can be used with a VFD, unless noted.

**Notes:** [1] Variable Frequency Drive (VFD) notes (see page 3.8 for Constant Torque Speed Ranges):  
All 1HP+ motors require EP suffix in model number and can be used with a VFD, unless noted.

# Single Reduction Selection Tables: Y5, Y6

**3 HP**  
(2.2 kW)

**Standard Mounting Positions:**

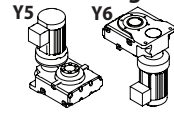

**Selection Table Pages:**

Single Reduction  
-Y1,Y2,Y3,Y4 3.10-3.38  
-Y5,Y6 3.39-3.60  
Double Reduction  
-Y1,Y2,Y3,Y4,Y5,Y6 3.62-3.79

**Dimension Pages:**

Single Reduction 3.80-3.85  
Double Reduction 3.86-3.91

Frequency	50 Hz	60 Hz
Input Speed	1450 RPM	1750 RPM
Number of Poles	4	

# Single Reduction Selection Tables: Y5, Y6

**5 HP**  
(3.7 kW)

**Standard Mounting Positions:**

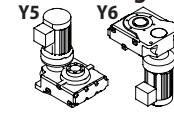

**Selection Table Pages:**

Single Reduction  
-Y1,Y2,Y3,Y4 3.10-3.38  
-Y5,Y6 3.39-3.60  
Double Reduction  
-Y1,Y2,Y3,Y4,Y5,Y6 3.62-3.79

**Dimension Pages:**

Single Reduction 3.80-3.85  
Double Reduction 3.86-3.91

Frequency	50 Hz	60 Hz
Input Speed	1450 RPM	1750 RPM
Number of Poles	4	

50Hz			60 Hz				Selection			VFD <sup>[1]</sup>
Output Speed (RPM)	Output Torque in-lbs (N·m)	Service Factor SF AGMA Class	Output Speed (RPM)	Output Torque in-lbs (N·m)	Service Factor SF AGMA Class	Motor Power Code	Base Frame Size	Ratio		
11.8	14500 (1640)	1.08 I	14.3	12000 (1360)	1.13 I	3	<b>B6120</b>	123		
		1.08 I			1.31 I		<b>B6125</b>	123		
		1.70 II			1.70 II		<b>C6145</b>	123		
9.63	17800 (2010)	0.87 -	11.6	14700 (1670)	0.87 -	3	<b>B6120</b>	151		
		0.88 -			1.06 I		<b>B6125</b>	151		
		1.70 II			1.70 II		<b>D6165</b>	151		
8.12	21100 (2380)	0.74 -	9.80	17500 (1980)	0.90 -	3	<b>B6125</b>	179		
		1.01 I			1.01 I		<b>C6145</b>	179		
		1.70 II			1.70 II		<b>D6165</b>	179		
		2.53 III			2.53 III		<b>E6175</b>	179		
7.02	24400 (2760)	1.01 I	8.47	20200 (2290)	1.01 I	3	<b>C6145</b>	207		
		1.70 II			1.70 II		<b>D6165</b>	207		
		2.53 III			2.53 III		<b>E6175</b>	207		
5.84	29400 (3320)	1.01 I	7.04	24300 (2750)	1.01 I	3	<b>D6165</b>	249		
		1.70 II			1.70 II		<b>E6175</b>	249		
4.76	36000 (4070)	1.01 I	5.75	29800 (3370)	1.01 I	3	<b>D6165</b>	305		
		1.70 II			1.70 II		<b>E6175</b>	305		

50Hz			60 Hz				Selection			VFD <sup>[1]</sup>
Output Speed (RPM)	Output Torque in-lbs (N·m)	Service Factor SF AGMA Class	Output Speed (RPM)	Output Torque in-lbs (N·m)	Service Factor SF AGMA Class	Motor Power Code	Base Frame Size	Ratio		
69.0	4180 (472)	1.37 I	83.3	3460 (391)	1.37 I	5	<b>B6120</b>	21		
		1.88 II			1.57 II		<b>B6125</b>	21		
		3.00 III			3.00 III		<b>C6145</b>	21		
51.8	5570 (629)	1.37 I	62.5	4610 (521)	1.37 I	5	<b>B6120</b>	28		
		1.88 II			1.88 II		<b>B6125</b>	28		
		3.00 III			3.00 III		<b>C6145</b>	28		
37.7	7660 (865)	1.37 I	45.5	6340 (717)	1.37 I	5	<b>B6120</b>	39		
		1.60 II			1.60 II		<b>B6125</b>	39		
		3.00 III			3.00 III		<b>C6145</b>	39		
31.9	9050 (1020)	1.37 I	38.5	7500 (847)	1.37 I	5	<b>B6120</b>	46		
		1.60 II			1.60 II		<b>B6125</b>	46		
		2.05 III			2.05 III		<b>C6145</b>	46		
		3.00 III			3.00 III		<b>D6165</b>	46		
27.6	10400 (1180)	1.37 I	33.3	8650 (977)	1.37 I	5	<b>B6120</b>	53		
		1.50 II			1.60 II		<b>B6125</b>	53		
		2.05 III			2.05 III		<b>C6145</b>	53		
		3.00 III			3.00 III		<b>D6165</b>	53		
24.4	11800 (1340)	1.32 I	29.4	9800 (1110)	1.37 I	5	<b>B6120</b>	60		
		1.32 I			1.53 II		<b>B6125</b>	60		
		3.00 III			3.00 III		<b>D6165</b>	60		
19.7	14600 (1650)	1.07 I	23.8	12100 (1370)	1.07 I	5	<b>B6120</b>	74		
		1.07 I			1.29 I		<b>B6125</b>	74		
		1.50 II			1.50 II		<b>C6145</b>	74		
		2.05 III			2.05 III		<b>D6165</b>	74		
		2.62 III			2.62 III		<b>E6175</b>	74		
16.6	17400 (1970)	0.83 -	20.0	14400 (1630)	0.83 -	5	<b>B6120</b>	88		
		0.90 -			1.07 I		<b>B6125</b>	88		
		1.50 II			1.50 II		<b>C6145</b>	88		
		2.05 III			2.05 III		<b>D6165</b>	88		
		3.00 III			3.00 III		<b>E6175</b>	88		
14.3	20200 (2280)	0.77 -	17.2	16700 (1890)	0.81 -	5	<b>B6120</b>	102		
		0.78 -			0.94 -		<b>B6125</b>	102		
		1.01 I			1.01 I		<b>C6145</b>	102		
		2.05 III			2.05 III		<b>D6165</b>	102		
		3.00 III			3.00 III		<b>E6175</b>	102		
11.8	24400 (2750)	1.01 I	14.3	20200 (2280)	1.01 I	5	<b>C6145</b>	123		
		2.05 III			2.05 III		<b>D6165</b>	123		

Notes: [1] Variable Frequency Drive (VFD) notes (see page 3.8 for Constant Torque Speed Ranges):  
All 1HP+ motors require EP suffix in model number and can be used with a VFD, unless noted.

Notes: [1] Variable Frequency Drive (VFD) notes (see page 3.8 for Constant Torque Speed Ranges):  
All 1HP+ motors require EP suffix in model number and can be used with a VFD, unless noted.

# Single Reduction Selection Tables: Y5, Y6

**5 HP  
(3.7 kW)**

**Standard Mounting Positions:**

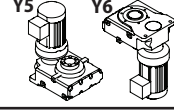

**Selection Table Pages:**

Single Reduction  
-Y1,Y2,Y3,Y4 3.10-3.38  
-Y5,Y6 3.39-3.60  
Double Reduction  
-Y1,Y2,Y3,Y4,Y5,Y6 3.62-3.79

**Dimension Pages:**

Single Reduction 3.80-3.85  
Double Reduction 3.86-3.91

Frequency	50 Hz	60 Hz
Input Speed	1450 RPM	1750 RPM
Number of Poles	4	

50Hz			60 Hz			Selection			VFD <sup>[1]</sup>	
Output Speed (RPM)	Output Torque		Output Speed (RPM)	Output Torque		Base				
	in-lbs	(N·m)		in-lbs	(N·m)	Motor Power Code	Frame Size	Ratio		
9.63	29900	(3380)	11.6	24800	(2800)	1.01	I	5	<b>D6165</b>	151
						2.05	III	5	<b>E6175</b>	151
8.12	35500	(4010)	9.80	29400	(3320)	1.01	I	5	<b>D6165</b>	179
						1.50	II	5	<b>E6175</b>	179
7.02	41100	(4640)	8.47	34000	(3840)	1.01	I	5	<b>D6165</b>	207
						1.50	II	5	<b>E6175</b>	207
5.84	49400	(5580)	7.04	40900	(4630)	1.01	I	5	<b>E6175</b>	249
4.76	60600	(6840)	5.75	50200	(5670)	1.01	I	5	<b>E6175</b>	305

# Single Reduction Selection Tables: Y5, Y6

**7.5 HP  
(5.5 kW)**

**Standard Mounting Positions:**

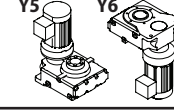

**Selection Table Pages:**

Single Reduction  
-Y1,Y2,Y3,Y4 3.10-3.38  
-Y5,Y6 3.39-3.60  
Double Reduction  
-Y1,Y2,Y3,Y4,Y5,Y6 3.62-3.79

**Dimension Pages:**

Single Reduction 3.80-3.85  
Double Reduction 3.86-3.91

Frequency	50 Hz	60 Hz
Input Speed	1450 RPM	1750 RPM
Number of Poles	4	

50Hz			60 Hz			Selection			VFD <sup>[1]</sup>	
Output Speed (RPM)	Output Torque		Output Speed (RPM)	Output Torque		Base				
	in-lbs	(N·m)		in-lbs	(N·m)	Motor Power Code	Frame Size	Ratio		
69.0	6210	(701)	83.3	5140	(581)	0.92	-	8	<b>B6120</b>	21
						1.27	I	8	<b>B6125</b>	21
						2.02	III	8	<b>C6145</b>	21
51.8	8280	(935)	62.5	6860	(775)	0.92	-	8	<b>B6120</b>	28
						1.26	I	8	<b>B6125</b>	28
						2.02	III	8	<b>C6145</b>	28
						2.75	III	8	<b>D6165</b>	28
37.7	11400	(1290)	45.5	9430	(1070)	0.92	-	8	<b>B6120</b>	39
						1.08	I	8	<b>B6125</b>	39
						2.02	III	8	<b>C6145</b>	39
						2.75	III	8	<b>D6165</b>	39
31.9	13400	(1520)	38.5	11100	(1260)	0.92	-	8	<b>B6120</b>	46
						1.08	I	8	<b>B6125</b>	46
						1.38	I	8	<b>C6145</b>	46
						2.02	III	8	<b>D6165</b>	46
						2.59	III	8	<b>E6175</b>	46
27.6	15500	(1750)	33.3	12900	(1450)	0.92	-	8	<b>B6120</b>	53
						1.01	I	8	<b>B6125</b>	53
						1.38	I	8	<b>C6145</b>	53
						2.02	III	8	<b>D6165</b>	53
						2.18	III	8	<b>E6175</b>	53
24.4	17600	(1990)	29.4	14600	(1650)	0.89	-	8	<b>B6120</b>	60
						0.89	-	8	<b>B6125</b>	60
						2.02	III	8	<b>D6165</b>	60
19.7	21700	(2450)	23.8	18000	(2030)	0.72	-	8	<b>B6125</b>	74
						1.01	I	8	<b>C6145</b>	74
						1.38	I	8	<b>D6165</b>	74
						1.77	II	8	<b>E6175</b>	74
16.6	25900	(2920)	20.0	21400	(2420)	1.01	I	8	<b>C6145</b>	88
						1.38	I	8	<b>D6165</b>	88
						2.02	III	8	<b>E6175</b>	88
14.3	30000	(3390)	17.2	24900	(2810)	1.38	I	8	<b>D6165</b>	102
						2.02	III	8	<b>E6175</b>	102
11.8	36200	(4090)	14.3	30000	(3390)	1.38	I	8	<b>D6165</b>	123
9.63	44500	(5030)	11.6	36900	(4160)	1.38	I	8	<b>E6175</b>	151
8.12	52800	(5960)	9.80	43700	(4940)	1.01	I	8	<b>E6175</b>	179

**Notes:** [1] Variable Frequency Drive (VFD) notes (see page 3.8 for Constant Torque Speed Ranges):  
All 1HP+ motors require EP suffix in model number and can be used with a VFD, unless noted.

**Notes:** [1] Variable Frequency Drive (VFD) notes (see page 3.8 for Constant Torque Speed Ranges):  
All 1HP+ motors require EP suffix in model number and can be used with a VFD, unless noted.

# Single Reduction Selection Tables: Y5, Y6

**7.5 HP  
(5.5 kW)**

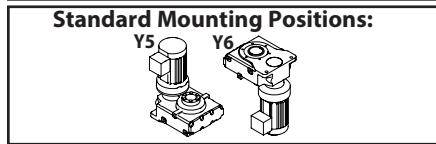

**Selection Table Pages:**

Single Reduction	
-Y1,Y2,Y3,Y4	3.10-3.38
-Y5,Y6	3.39-3.60
Double Reduction	
-Y1,Y2,Y3,Y4,Y5,Y6	3.62-3.79

**Dimension Pages:**

Single Reduction	3.80-3.85
Double Reduction	3.86-3.91

Frequency	50 Hz	60 Hz
Input Speed	1450 RPM	1750 RPM
Number of Poles	4	

50Hz				60 Hz				Selection					
Output Speed (RPM)	Output Torque		Service Factor		Output Speed (RPM)	Output Torque		Service Factor		Base			VFD <sup>[1]</sup>
	in-lbs	(N·m)	SF	AGMA Class		in-lbs	(N·m)	SF	AGMA Class	Motor Power Code	Frame Size	Ratio	
7.02	61000	(6900)	1.01	I	8.47	50600	(5710)	1.01	I	8	<b>E6175</b>	207	

# Single Reduction Selection Tables: Y5,Y6

**10 HP  
(7.5 kW)**

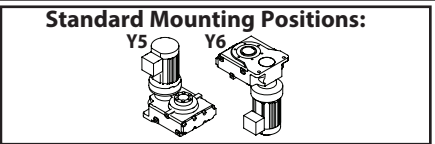

**Selection Table Pages:**

Single Reduction	
-Y1,Y2,Y3,Y4	3.10-3.38
-Y5,Y6	3.39-3.60
Double Reduction	
-Y1,Y2,Y3,Y4,Y5,Y6	3.62-3.79

**Dimension Pages:**

Single Reduction	3.80-3.85
Double Reduction	3.86-3.91

Frequency	50 Hz	60 Hz
Input Speed	1450 RPM	1750 RPM
Number of Poles	4	

50Hz				60 Hz				Selection					
Output Speed (RPM)	Output Torque		Service Factor		Output Speed (RPM)	Output Torque		Service Factor		Base			VFD <sup>[1]</sup>
	in-lbs	(N·m)	SF	AGMA Class		in-lbs	(N·m)	SF	AGMA Class	Motor Power Code	Frame Size	Ratio	
69.0	8470	(956)	1.48	II	83.3	7010	(792)	1.48	II	10	<b>C6145</b>	21	
51.8	11300	(1280)	0.93	-	62.5	9350	(1060)	0.93	-	10	<b>B6125</b>	28	
			1.48	II				10	<b>C6145</b>	28			
			2.02	III				10	<b>D6165</b>	28			
37.7	15500	(1750)	1.48	II	45.5	12900	(1450)	1.48	II	10	<b>C6145</b>	39	
			2.02	III				10	<b>D6165</b>	39			
31.9	18300	(2070)	1.01	I	38.5	15200	(1720)	1.01	I	10	<b>C6145</b>	46	
			1.48	II				10	<b>D6165</b>	46			
			1.90	II				10	<b>E6175</b>	46	(-)		
27.6	21200	(2390)	1.01	I	33.3	17500	(1980)	1.01	I	10	<b>C6145</b>	53	
			1.48	II				10	<b>D6165</b>	53			
			1.60	II				10	<b>E6175</b>	53			
24.4	24000	(2710)	1.48	II	29.4	19900	(2250)	1.48	II	10	<b>D6165</b>	60	
19.7	29600	(3350)	1.01	I	23.8	24500	(2770)	1.01	I	10	<b>D6165</b>	74	
			1.29	I				10	<b>E6175</b>	74			
16.6	35300	(3990)	1.01	I	20.0	29200	(3300)	1.01	I	10	<b>D6165</b>	88	
			1.48	II				10	<b>E6175</b>	88			
14.3	40900	(4620)	1.01	I	17.2	33900	(3830)	1.01	I	10	<b>D6165</b>	102	
			1.48	II				10	<b>E6175</b>	102			
11.8	49400	(5580)	1.01	I	14.3	40900	(4620)	1.01	I	10	<b>D6165</b>	123	
9.63	60700	(6850)	1.01	I	11.6	50300	(5680)	1.01	I	10	<b>E6175</b>	151	

**Notes:** [1] Variable Frequency Drive (VFD) notes (see page 3.8 for Constant Torque Speed Ranges):  
All 1HP+ motors require EP suffix in model number and can be used with a VFD, unless noted.

**Notes:** [1] Variable Frequency Drive (VFD) notes (see page 3.8 for Constant Torque Speed Ranges):  
All 1HP+ motors require EP suffix in model number and can be used with a VFD, unless noted.



# Single Reduction Selection Tables: Y5, Y6

**15 HP  
(11 kW)**

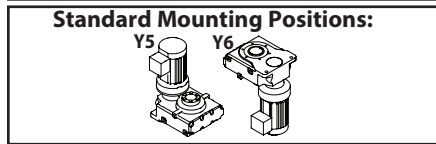

**Selection Table Pages:**

Single Reduction	
-Y1,Y2,Y3,Y4	3.10-3.38
-Y5,Y6	3.39-3.60
Double Reduction	
-Y1,Y2,Y3,Y4,Y5,Y6	3.62-3.79

**Dimension Pages:**

Single Reduction	3.80-3.85
Double Reduction	3.86-3.91

Frequency	50 Hz	60 Hz
Input Speed	1450 RPM	1750 RPM
Number of Poles	4	

50Hz				60 Hz				Selection					
Output Speed (RPM)	Output Torque		Service Factor		Output Speed (RPM)	Output Torque		Service Factor		Base			VFD <sup>[1]</sup>
	in-lbs	(N·m)	SF	AGMA Class		in-lbs	(N·m)	SF	AGMA Class	Motor Power Code	Frame Size	Ratio	
69.0	12400	(1400)	1.01	I	83.3	10300	(1160)	1.01	I	15	<b>C6145</b>	21	
51.8	16600	(1870)	1.01	I	62.5	13700	(1550)	1.01	I	15	<b>C6145</b>	28	
			1.38	I				1.38	I			15	<b>D6165</b>
37.7	22800	(2570)	1.01	I	45.5	18900	(2130)	1.01	I	15	<b>C6145</b>	39	
			1.38	I				1.38	I			15	<b>D6165</b>
31.9	26900	(3040)	1.01	I	38.5	22300	(2520)	1.01	I	15	<b>D6165</b>	46	
			1.29	I				1.29	I			15	<b>E6175</b>
27.6	31000	(3510)	1.01	I	33.3	25700	(2910)	1.01	I	15	<b>D6165</b>	53	
			1.09	I				1.09	I			15	<b>E6175</b>
24.4	35200	(3970)	1.01	I	29.4	29100	(3290)	1.01	I	15	<b>D6165</b>	60	
19.7	43500	(4910)	0.88	-	23.8	36000	(4070)	0.88	-	15	<b>E6175</b>	74	
16.6	51700	(5840)	1.01	I	20.0	42900	(4840)	1.01	I	15	<b>E6175</b>	88	
14.3	60000	(6780)	1.01	I	17.2	49700	(5620)	1.01	I	15	<b>E6175</b>	102	

# Single Reduction Selection Tables: Y5, Y6

**20 HP  
(15 kW)**

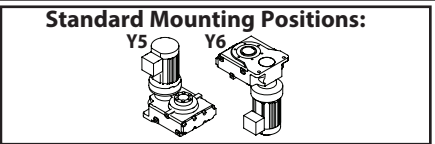

**Selection Table Pages:**

Single Reduction	
-Y1,Y2,Y3,Y4	3.10-3.38
-Y5,Y6	3.39-3.60
Double Reduction	
-Y1,Y2,Y3,Y4,Y5,Y6	3.62-3.79

**Dimension Pages:**

Single Reduction	3.80-3.85
Double Reduction	3.86-3.91

Frequency	50 Hz	60 Hz
Input Speed	1450 RPM	1750 RPM
Number of Poles	4	

50Hz				60 Hz				Selection					
Output Speed (RPM)	Output Torque		Service Factor		Output Speed (RPM)	Output Torque		Service Factor		Base			VFD <sup>[1]</sup>
	in-lbs	(N·m)	SF	AGMA Class		in-lbs	(N·m)	SF	AGMA Class	Motor Power Code	Frame Size	Ratio	
51.8	22600	(2550)	1.01	I	62.5	18700	(2110)	1.01	I	20	<b>D6165</b>	28	
37.7	31000	(3510)	1.01	I	45.5	25700	(2910)	1.01	I	20	<b>D6165</b>	39	
31.9	36700	(4140)	0.95	-	38.5	30400	(3430)	0.95	-	20	<b>E6175</b>	46	
27.6	42300	(4780)	0.80	-	33.3	35100	(3960)	0.80	-	20	<b>E6175</b>	53	

**Notes:** [1] Variable Frequency Drive (VFD) notes (see page 3.8 for Constant Torque Speed Ranges):  
All 1HP+ motors require EP suffix in model number and can be used with a VFD, unless noted.

**Notes:** [1] Variable Frequency Drive (VFD) notes (see page 3.8 for Constant Torque Speed Ranges):  
All 1HP+ motors require EP suffix in model number and can be used with a VFD, unless noted.

# Single Reduction Selection Tables: Y5, Y6

**25 HP  
(18.5 kW)**

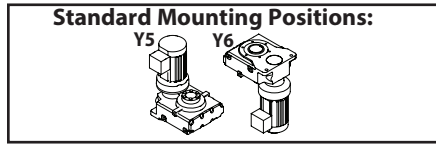

**Selection Table Pages:**

Single Reduction	
-Y1,Y2,Y3,Y4	3.10-3.38
-Y5,Y6	3.39-3.60
Double Reduction	
-Y1,Y2,Y3,Y4,Y5,Y6	3.62-3.79

**Dimension Pages:**

Single Reduction	3.80-3.85
Double Reduction	3.86-3.91

Frequency	50 Hz	60 Hz
Input Speed	1450 RPM	1750 RPM
Number of Poles	4	

This page intentionally left blank.

50Hz				60 Hz				Selection					
Output Speed (RPM)	Output Torque		Service Factor		Output Speed (RPM)	Output Torque		Service Factor		Base			VFD <sup>[1]</sup>
	in-lbs	(N·m)	SF	AGMA Class		in-lbs	(N·m)	SF	AGMA Class	Motor Power Code	Frame Size	Ratio	
51.8	27800	(3150)	0.82	-	62.5	23100	(2610)	0.82	-	25	<b>D6165</b>	28	
37.7	38300	(4330)	0.82	-	45.5	31700	(3580)	0.82	-	25	<b>D6165</b>	39	

**Notes:** [1] Variable Frequency Drive (VFD) notes (see page 3.8 for Constant Torque Speed Ranges):  
All 1HP+ motors require EP suffix in model number and can be used with a VFD, unless noted.



# Double Reduction Selection Tables: Y1,Y2,Y3,Y4,Y5,Y6

**1/4 HP  
(0.2 kW)**

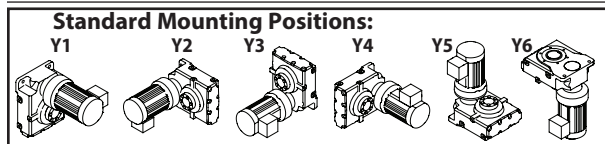

Dimension Pages:  
Single Reduction 3.80-3.85  
Double Reduction 3.86-3.91

Frequency	50 Hz	60 Hz
Input Speed	1450 RPM	1750 RPM
Number of Poles	4	

50Hz			60 Hz			Selection			VFD <sup>[1]</sup>
Output Speed (RPM)	Output Torque in-lbs (N·m)	Service Factor SF AGMA Class	Output Speed (RPM)	Output Torque in-lbs (N·m)	Service Factor SF AGMA Class	Motor Power Code	Base Frame Size	Ratio	
0.638	24400 (2760)	0.68 - I	0.770	20200 (2290)	0.82 - I	02	<b>B612DB</b>	2272	(a)
		1.35 II			02	<b>C614DB</b>	2272	(a)	
		2.35 III			02	<b>D616DA</b>	2272	(a)	
0.567	27500 (3110)	0.60 - I	0.684	22800 (2570)	0.72 - I	02	<b>B612DB</b>	2559	(a)
		1.20 II			02	<b>C614DB</b>	2559	(a)	
		2.08 III			02	<b>D616DA</b>	2559	(a)	
		2.91 III			02	<b>E617DA</b>	2559	(a)	
0.493	31600 (3570)	0.52 - I	0.595	26200 (2960)	0.63 - I	02	<b>B612DB</b>	2944	(a)
		1.04 II			02	<b>C614DB</b>	2944	(a)	
		2.53 III			02	<b>E617DA</b>	2944	(a)	
0.413	37700 (4260)	0.44 - I	0.499	31300 (3530)	0.53 - I	02	<b>B612DB</b>	3511	(a)
		0.87 - I			02	<b>C614DB</b>	3511	(a)	
0.332	46900 (5300)	0.70 - I	0.401	38900 (4390)	0.85 - I	02	<b>C614DB</b>	4365	(a)
0.280	55600 (6290)	0.59 - I	0.338	46100 (5210)	0.72 - I	02	<b>C614DB</b>	5177	(a)
0.224	69600 (7860)	0.47 - I	0.270	57600 (6510)	0.57 - I	02	<b>C614DB</b>	6472	(a)
0.201	77700 (8780)	0.42 - I	0.242	64400 (7270)	0.51 - I	02	<b>C614DB</b>	7228	(a)
		0.74 - I			02	<b>D616DA</b>	7228	(a)	
0.163	95400 (10800)	0.60 - I	0.197	79100 (8940)	0.72 - I	02	<b>D616DA</b>	8880	(a)
0.136	115000 (12900)	0.50 - I	0.164	94900 (10700)	0.60 - I	02	<b>D616DA</b>	10658	(a)
		0.70 - I			02	<b>E617DA</b>	10658	(a)	
0.119	131000 (14800)	0.44 - I	0.144	109000 (12300)	0.53 - I	02	<b>D616DA</b>	12184	(a)
		0.61 - I			02	<b>E617DA</b>	12184	(a)	
0.0934	167000 (18900)	0.48 - I	0.113	138000 (15600)	0.58 - I	02	<b>E617DA</b>	15530	(a)
0.0807	193000 (21800)	0.41 - I	0.0974	160000 (18100)	0.50 - I	02	<b>E617DA</b>	17966	(a)

# Double Reduction Selection Tables: Y1,Y2,Y3,Y4,Y5,Y6

**1/3 HP  
(0.25 kW)**

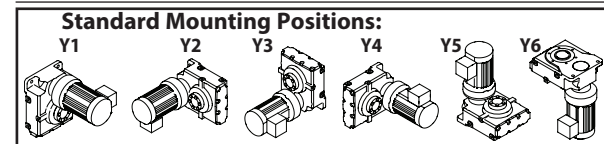

Dimension Pages:  
Single Reduction 3.80-3.85  
Double Reduction 3.86-3.91

Frequency	50 Hz	60 Hz
Input Speed	1450 RPM	1750 RPM
Number of Poles	4	

50Hz			60 Hz			Selection			VFD <sup>[1]</sup>
Output Speed (RPM)	Output Torque in-lbs (N·m)	Service Factor SF AGMA Class	Output Speed (RPM)	Output Torque in-lbs (N·m)	Service Factor SF AGMA Class	Motor Power Code	Base Frame Size	Ratio	
3.98	4890 (553)	0.83 - I	4.81	4050 (458)	1.01 I	03	<b>Z609DA</b>	364	(a)
		1.69 II			03	<b>A610DA</b>	364	(a)	
3.42	5690 (643)	0.72 - I	4.13	4710 (533)	0.86 - I	03	<b>Z609DA</b>	424	(a)
		1.45 II			03	<b>A610DA</b>	424	(a)	
		2.90 III			03	<b>B612DB</b>	424	(a)	
2.90	6720 (760)	0.61 - I	3.50	5570 (630)	0.73 - I	03	<b>Z609DA</b>	501	(a)
		1.23 II			03	<b>A610DA</b>	501	(a)	
		1.72 II			03	<b>B612DA</b>	501	(a)	
2.51	7760 (877)	0.53 - I	3.03	6430 (726)	0.63 - I	03	<b>Z609DA</b>	578	(a)
		1.06 II			03	<b>A610DA</b>	578	(a)	
		1.72 II			03	<b>B612DA</b>	578	(a)	
2.12	9170 (1040)	0.44 - I	2.56	7600 (859)	0.54 - I	03	<b>Z609DA</b>	683	(a)
		0.90 - I			03	<b>A610DA</b>	683	(a)	
		1.72 II			03	<b>B612DA</b>	683	(a)	
1.79	10900 (1230)	0.76 - I	2.16	9000 (1020)	0.92 - I	03	<b>A610DA</b>	809	(a)
		1.52 II			03	<b>B612DA</b>	809	(a)	
		1.52 II			03	<b>B612DB</b>	809	(a)	
1.52	12800 (1450)	0.64 - I	1.83	10600 (1200)	0.78 - I	03	<b>A610DA</b>	956	(a)
		1.29 II			03	<b>B612DB</b>	956	(a)	
		1.72 II			03	<b>C614DA</b>	956	(a)	
1.30	15000 (1690)	0.55 - I	1.57	12400 (1400)	0.66 - I	03	<b>A610DA</b>	1117	(a)
		1.10 II			03	<b>B612DB</b>	1117	(a)	
		1.72 II			03	<b>C614DA</b>	1117	(a)	
1.10	17700 (2000)	0.47 - I	1.33	14700 (1660)	0.56 - I	03	<b>A610DA</b>	1320	(a)
		0.93 - I			03	<b>B612DB</b>	1320	(a)	
		1.72 II			03	<b>C614DA</b>	1320	(a)	
0.876	22200 (2510)	0.74 - I	1.06	18400 (2080)	0.90 - I	03	<b>B612DB</b>	1656	(a)
		1.48 II			03	<b>C614DA</b>	1656	(a)	
		1.48 II			03	<b>C614DB</b>	1656	(a)	
		2.57 III			03	<b>D616DA</b>	1656	(a)	

Notes: [1] Variable Frequency Drive (VFD) notes (see page 3.8 for Constant Torque Speed Ranges):  
 (-) = For Inverter Operation, starting condition may require ambient temperature of 5° C or higher.  
 (a) = Both AV and non-AV motors can be used for selection.

Notes: [1] Variable Frequency Drive (VFD) notes (see page 3.8 for Constant Torque Speed Ranges):  
 (-) = For Inverter Operation, starting condition may require ambient temperature of 5° C or higher.  
 (a) = Both AV and non-AV motors can be used for selection.

# Double Reduction Selection Tables: Y1,Y2,Y3,Y4,Y5,Y6

**1/3 HP  
(0.25 kW)**

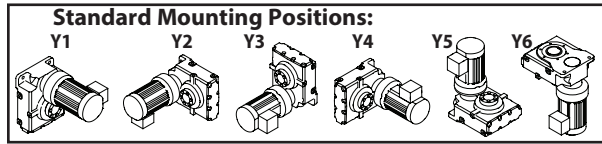

Dimension Pages:  
Single Reduction 3.80-3.85  
Double Reduction 3.86-3.91

Frequency	50 Hz	60 Hz
Input Speed	1450 RPM	1750 RPM
Number of Poles	4	

50Hz				60 Hz				Selection					
Output Speed (RPM)	Output Torque		Service Factor		Output Speed (RPM)	Output Torque		Service Factor		Base			VFD <sup>[1]</sup>
	in-lbs	(N·m)	SF	AGMA Class		in-lbs	(N·m)	SF	AGMA Class	Motor Power Code	Frame Size	Ratio	
0.741	26300 (2970)		0.63	-	0.894	21800 (2460)		0.76	-	03	B612DB	1957	(a)
			1.26	I				03	C614DB	1957	(a)		
			2.18	III				03	D616DA	1957	(a)		
			3.04	III				03	E617DA	1957	(a)		
0.638	30500 (3450)		0.54	-	0.770	25300 (2860)		0.65	-	03	B612DB	2272	(a)
			1.08	I				03	C614DB	2272	(a)		
			1.88	II				03	D616DA	2272	(a)		
			2.62	III				03	E617DA	2272	(a)		
0.567	34400 (3880)		0.48	-	0.684	28500 (3220)		0.58	-	03	B612DB	2559	(a)
			0.96	-				03	C614DB	2559	(a)		
			1.67	II				03	D616DA	2559	(a)		
			2.32	III				03	E617DA	2559	(a)		
0.493	39600 (4470)		0.42	-	0.595	32800 (3700)		0.50	-	03	B612DB	2944	(a)
			0.83	-				03	C614DB	2944	(a)		
			2.02	III				03	E617DA	2944	(a)		
0.413	47200 (5330)		0.70	-	0.499	39100 (4420)		0.84	-	03	C614DB	3511	(a)
0.332	58600 (6630)		0.56	-	0.401	48600 (5490)		0.68	-	03	C614DB	4365	(a)
0.280	69600 (7860)		0.47	-	0.338	57600 (6510)		0.57	-	03	C614DB	5177	(a)
0.201	97100 (11000)		0.59	-	0.242	80500 (9090)		0.71	-	03	D616DA	7228	(a)
0.163	119000 (13500)		0.48	-	0.197	98900 (11200)		0.58	-	03	D616DA	8880	(a)
0.136	143000 (16200)		0.56	-	0.164	119000 (13400)		0.67	-	03	E617DA	10658	(a)
0.119	164000 (18500)		0.49	-	0.144	136000 (15300)		0.59	-	03	E617DA	12184	(a)

# Double Reduction Selection Tables: Y1,Y2,Y3,Y4,Y5,Y6

**1/2 HP  
(0.4 kW)**

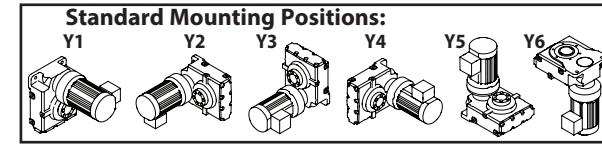

Dimension Pages:  
Single Reduction 3.80-3.85  
Double Reduction 3.86-3.91

Frequency	50 Hz	60 Hz
Input Speed	1450 RPM	1750 RPM
Number of Poles	4	

50Hz				60 Hz				Selection					
Output Speed (RPM)	Output Torque		Service Factor		Output Speed (RPM)	Output Torque		Service Factor		Base			VFD <sup>[1]</sup>
	in-lbs	(N·m)	SF	AGMA Class		in-lbs	(N·m)	SF	AGMA Class	Motor Power Code	Frame Size	Ratio	
3.98	7830 (884)		0.52	-	4.81	6480 (733)		0.63	-	05	Z609DA	364	
			1.05	I				05	A610DA	364			
			2.11	III				05	B612DB	364	(a)		
3.42	9100 (1030)		0.45	-	4.13	7540 (852)		0.54	-	05	Z609DA	424	
			0.91	-				05	A610DA	424			
			1.81	II				05	B612DB	424	(a)		
2.90	10800 (1220)		0.77	-	3.50	8920 (1010)		0.92	-	05	A610DA	501	
			1.07	I				05	B612DA	501			
			1.53	II				05	B612DB	501	(a)		
2.51	12400 (1400)		0.66	-	3.03	10300 (1160)		0.80	-	05	A610DA	578	
			1.07	I				05	B612DA	578			
			1.33	I				05	B612DB	578	(a)		
2.12	14700 (1660)		0.56	-	2.56	12200 (1370)		0.68	-	05	A610DA	683	
			1.07	I				05	B612DA	683			
			1.13	I				05	B612DB	683	(a)		
1.79	17400 (1960)		0.47	-	2.16	14400 (1630)		0.57	-	05	A610DA	809	
			0.95	-				05	B612DA	809			
			0.95	-				05	B612DB	809	(a)		
1.52	20500 (2320)		0.80	-	1.83	17000 (1920)		0.97	-	05	B612DB	956	(a)
			1.07	I				05	C614DA	956			
			1.61	II				05	C614DB	956	(a)		
1.30	24000 (2710)		0.69	-	1.57	19900 (2250)		0.83	-	05	B612DA	1117	
			1.07	I				05	C614DA	1117			
			1.38	I				05	C614DB	1117	(a)		
1.10	28400 (3210)		0.58	-	1.33	23500 (2660)		0.70	-	05	B612DA	1320	
			1.07	I				05	C614DA	1320			
			1.16	I				05	C614DB	1320	(a)		
			2.02	III				2.44	III	05	D616DA	1320	(a)
			2.82	III				05	E617DA	1320	(a)		

Notes: [1] Variable Frequency Drive (VFD) notes (see page 3.8 for Constant Torque Speed Ranges):  
 (-) = For Inverter Operation, starting condition may require ambient temperature of 5° C or higher.  
 (a) = Both AV and non-AV motors can be used for selection.

Notes: [1] Variable Frequency Drive (VFD) notes (see page 3.8 for Constant Torque Speed Ranges):  
 (-) = For Inverter Operation, starting condition may require ambient temperature of 5° C or higher.  
 (a) = Both AV and non-AV motors can be used for selection.

# Double Reduction Selection Tables: Y1,Y2,Y3,Y4,Y5,Y6

**1/2 HP  
(0.4 kW)**

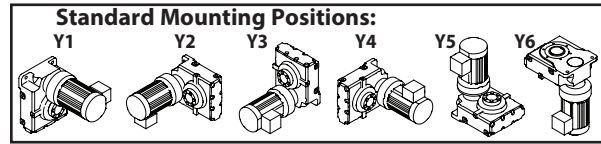

Dimension Pages:  
 Single Reduction 3.80-3.85  
 Double Reduction 3.86-3.91

Frequency	50 Hz	60 Hz
Input Speed	1450 RPM	1750 RPM
Number of Poles	4	

# Double Reduction Selection Tables: Y1,Y2,Y3,Y4,Y5,Y6

**3/4 HP  
(0.55 kW)**

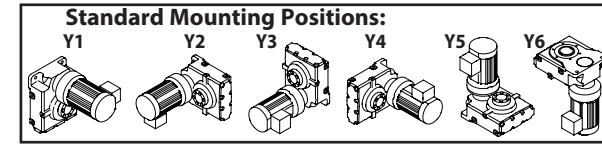

Dimension Pages:  
 Single Reduction 3.80-3.85  
 Double Reduction 3.86-3.91

Frequency	50 Hz	60 Hz
Input Speed	1450 RPM	1750 RPM
Number of Poles	4	

50Hz				60 Hz				Selection					
Output Speed (RPM)	Output Torque		Service Factor		Output Speed (RPM)	Output Torque		Service Factor		Base			VFD <sup>[1]</sup>
	in-lbs	(N·m)	SF	AGMA Class		in-lbs	(N·m)	SF	AGMA Class	Motor Power Code	Frame Size	Ratio	
0.876	35600	(4020)	0.46	-	1.06	29500	(3330)	0.56	-	05	B612DA	1656	(a)
			0.93	-				05	C614DA	1656			
			0.93	-				05	C614DB	1656			
			1.61	II				05	D616DA	1656			
			2.25	III				05	E617DA	1656			
0.741	42100	(4750)	0.78	-	0.894	34900	(3940)	0.95	-	05	C614DB	1957	(a)
			1.36	I				05	D616DA	1957	(a)		
			1.90	II				05	E617DA	1957	(a)		
0.638	48800	(5520)	0.68	-	0.770	40500	(4570)	0.82	-	05	C614DB	2272	(a)
			1.17	I				05	D616DA	2272	(a)		
			1.64	II				05	E617DA	2272	(a)		
0.567	55000	(6210)	0.60	-	0.684	45600	(5150)	0.72	-	05	C614DB	2559	(a)
			1.04	I				05	D616DA	2559	(a)		
			1.45	II				05	E617DA	2559	(a)		
0.493	63300	(7150)	0.52	-	0.595	52400	(5920)	0.63	-	05	C614DB	2944	(a)
			0.90	-				05	D616DA	2944	(a)		
			1.26	I				05	E617DA	2944	(a)		
0.413	75500	(8530)	0.44	-	0.499	62500	(7070)	0.53	-	05	C614DB	3511	(a)
			0.76	-				05	D616DA	3511	(a)		
			1.06	I				05	E617DA	3511	(a)		
0.332	93800	(10600)	0.61	-	0.401	77700	(8780)	0.74	-	05	D616DA	4365	(a)
			0.85	-				05	E617DA	4365	(a)		
0.280	111000	(12600)	0.51	-	0.338	92200	(10400)	0.62	-	05	D616DA	5177	(a)
			0.72	-				05	E617DA	5177	(a)		
0.224	139000	(15700)	0.41	-	0.270	115000	(13000)	0.50	-	05	D616DA	6472	(a)
			0.57	-				05	E617DA	6472	(a)		
0.201	155000	(17600)	0.51	-	0.242	129000	(14500)	0.62	-	05	E617DA	7228	(a)
0.163	191000	(21600)	0.42	-	0.197	158000	(17900)	0.51	-	05	E617DA	8880	(a)

50Hz				60 Hz				Selection					
Output Speed (RPM)	Output Torque		Service Factor		Output Speed (RPM)	Output Torque		Service Factor		Base			VFD <sup>[1]</sup>
	in-lbs	(N·m)	SF	AGMA Class		in-lbs	(N·m)	SF	AGMA Class	Motor Power Code	Frame Size	Ratio	
3.98	10800	(1220)	1.53	II	4.81	8920	(1010)	1.85	II	08	B612DB	364	(a)
			2.91	III				08	C614DB	364	(a)		
			3.07	III				08	C614DC	364	(a),(-)		
3.42	12500	(1410)	1.32	I	4.13	10400	(1170)	1.59	II	08	B612DB	424	(a)
			2.64	III				08	C614DB	424	(a)		
			2.64	III				08	C614DC	424	(a),(-)		
2.90	14800	(1670)	1.12	I	3.50	12300	(1390)	1.35	I	08	B612DB	501	(a)
			2.23	III				08	C614DB	501	(a)		
			2.91	III				08	D616DA	501	(a)		
2.51	17100	(1930)	0.97	-	3.03	14100	(1600)	1.17	I	08	B612DB	578	(a)
			1.93	II				08	C614DB	578	(a)		
			2.91	III				08	D616DA	578	(a)		
2.12	20200	(2280)	0.82	-	2.56	16700	(1890)	0.99	-	08	B612DB	683	(a)
			1.64	II				08	C614DB	683	(a)		
			2.84	III				08	D616DA	683	(a)		
1.79	23900	(2700)	0.69	-	2.16	19800	(2240)	0.83	-	08	B612DB	809	(a)
			1.38	I				08	C614DB	809	(a)		
			2.40	III				08	D616DA	809	(a)		
1.52	28200	(3190)	0.58	-	1.83	23400	(2640)	0.71	-	08	B612DB	956	(a)
			1.17	I				08	C614DB	956	(a)		
			2.03	III				08	D616DA	956	(a)		
1.30	33000	(3730)	0.50	-	1.57	27300	(3090)	0.60	-	08	B612DB	1117	(a)
			1.00	I				08	C614DB	1117	(a)		
			1.74	II				08	D616DA	1117	(a)		
1.10	39000	(4410)	0.42	-	1.33	32300	(3650)	0.51	-	08	B612DB	1320	(a)
			0.85	-				08	C614DB	1320	(a)		
			1.47	II				08	D616DA	1320	(a)		
0.876	48900	(5530)	0.67	-	1.06	40500	(4580)	0.81	-	08	C614DB	1656	(a)
			1.17	I				08	D616DA	1656	(a)		
			1.63	II				08	E617DA	1656	(a)		

Notes: [1] Variable Frequency Drive (VFD) notes (see page 3.8 for Constant Torque Speed Ranges):  
 (-) = For Inverter Operation, starting condition may require ambient temperature of 5° C or higher.  
 (a) = Both AV and non-AV motors can be used for selection.

Notes: [1] Variable Frequency Drive (VFD) notes (see page 3.8 for Constant Torque Speed Ranges):  
 (-) = For Inverter Operation, starting condition may require ambient temperature of 5° C or higher.  
 (a) = Both AV and non-AV motors can be used for selection.

# Double Reduction Selection Tables: Y1,Y2,Y3,Y4,Y5,Y6

**3/4 HP  
(0.55 kW)**

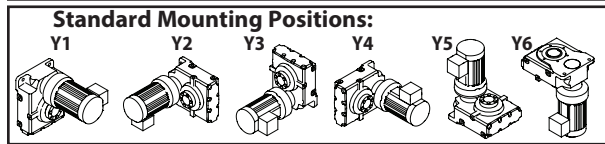

Dimension Pages:  
Single Reduction 3.80-3.85  
Double Reduction 3.86-3.91

Frequency	50 Hz	60 Hz
Input Speed	1450 RPM	1750 RPM
Number of Poles	4	

50Hz				60 Hz				Selection			VFD <sup>[1]</sup>		
Output Speed (RPM)	Output Torque		Service Factor		Output Speed (RPM)	Output Torque		Service Factor		Base			
	in-lbs	(N·m)	SF	AGMA Class		in-lbs	(N·m)	SF	AGMA Class	Motor Power Code	Frame Size	Ratio	
0.741	57800	(6530)	0.57	-	0.894	47900	(5410)	0.69	-	08	<b>C614DB</b>	1957	(a)
			0.99	-				08	<b>D616DA</b>	1957	(a)		
			1.38	I				08	<b>E617DA</b>	1957	(a)		
0.638	67100	(7590)	0.49	-	0.770	55600	(6290)	0.59	-	08	<b>C614DB</b>	2272	(a)
			0.85	-				08	<b>D616DA</b>	2272	(a)		
			1.19	I				08	<b>E617DA</b>	2272	(a)		
0.567	75600	(8550)	0.44	-	0.684	62700	(7080)	0.53	-	08	<b>C614DB</b>	2559	(a)
			0.76	-				08	<b>D616DA</b>	2559	(a)		
			1.06	I				08	<b>E617DA</b>	2559	(a)		
0.493	87000	(9830)	0.66	-	0.595	72100	(8150)	0.79	-	08	<b>D616DA</b>	2944	(a)
			0.92	-				08	<b>E617DA</b>	2944	(a)		
0.413	104000	(11700)	0.55	-	0.499	86000	(9710)	0.67	-	08	<b>D616DA</b>	3511	(a)
			0.77	-				08	<b>E617DA</b>	3511	(a)		
0.332	129000	(14600)	0.44	-	0.401	107000	(12100)	0.54	-	08	<b>D616DA</b>	4365	(a)
			0.62	-				08	<b>E617DA</b>	4365	(a)		
0.280	153000	(17300)	0.52	-	0.338	127000	(14300)	0.63	-	08	<b>E617DA</b>	5177	(a)
0.224	191000	(21600)	0.42	-	0.270	159000	(17900)	0.50	-	08	<b>E617DA</b>	6472	(a)

# Double Reduction Selection Tables: Y1,Y2,Y3,Y4,Y5,Y6

**1 HP  
(0.75 kW)**

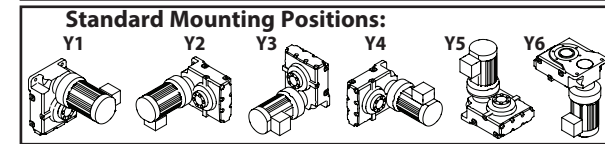

Dimension Pages:  
Single Reduction 3.80-3.85  
Double Reduction 3.86-3.91

Frequency	50 Hz	60 Hz
Input Speed	1450 RPM	1750 RPM
Number of Poles	4	

50Hz				60 Hz				Selection			VFD <sup>[1]</sup>		
Output Speed (RPM)	Output Torque		Service Factor		Output Speed (RPM)	Output Torque		Service Factor		Base			
	in-lbs	(N·m)	SF	AGMA Class		in-lbs	(N·m)	SF	AGMA Class	Motor Power Code	Frame Size	Ratio	
3.98	14700	(1660)	1.13	I	4.81	12200	(1370)	1.36	I	1	<b>B612DB</b>	364	
			2.13	III				1	<b>C614DB</b>	364			
			2.25	III				1	<b>C614DC</b>	364			
3.42	17100	(1930)	0.97	-	4.13	14100	(1600)	1.17	I	1	<b>B612DB</b>	424	
			1.93	II				1	<b>C614DB</b>	424			
			1.93	II				1	<b>C614DC</b>	424			
2.90	20200	(2280)	0.82	-	3.50	16700	(1890)	0.99	-	1	<b>B612DB</b>	501	
			1.64	II				1	<b>C614DB</b>	501			
			2.13	III				1	<b>D616DA</b>	501			
2.51	23300	(2630)	0.71	-	3.03	19300	(2180)	0.86	-	1	<b>B612DB</b>	578	
			1.42	II				1	<b>C614DB</b>	578			
			2.13	III				1	<b>D616DA</b>	578			
2.12	27500	(3110)	0.60	-	2.56	22800	(2580)	0.72	-	1	<b>B612DB</b>	683	
			1.20	I				1	<b>C614DB</b>	683			
			2.08	III				1	<b>D616DA</b>	683			
1.79	32600	(3680)	0.51	-	2.16	27000	(3050)	0.61	-	1	<b>B612DB</b>	809	
			1.01	I				1	<b>C614DB</b>	809			
			1.76	II				1	<b>D616DA</b>	809			
1.52	38500	(4350)	0.43	-	1.83	31900	(3610)	0.52	-	1	<b>B612DB</b>	956	
			0.86	-				1	<b>C614DB</b>	956			
			1.49	II				1	<b>D616DA</b>	956			
1.30	45000	(5080)	0.73	-	1.57	37300	(4210)	0.89	-	1	<b>C614DB</b>	1117	
			1.27	I				1	<b>D616DA</b>	1117			
			1.78	II				1	<b>E617DA</b>	1117			
1.10	53200	(6010)	0.62	-	1.33	44100	(4980)	0.75	-	1	<b>C614DB</b>	1320	
			1.08	I				1	<b>D616DA</b>	1320			
			1.50	II				1	<b>E617DA</b>	1320			
0.876	66700	(7540)	0.49	-	1.06	55300	(6250)	0.60	-	1	<b>C614DB</b>	1656	
			0.86	-				1	<b>D616DA</b>	1656			
			1.20	I				1	<b>E617DA</b>	1656			

Notes: [1] Variable Frequency Drive (VFD) notes (see page 3.8 for Constant Torque Speed Ranges):  
 (-) = For Inverter Operation, starting condition may require ambient temperature of 5° C or higher.  
 (a) = Both AV and non-AV motors can be used for selection.

Notes: [1] Variable Frequency Drive (VFD) notes (see page 3.8 for Constant Torque Speed Ranges):  
 (-) = For Inverter Operation, starting condition may require ambient temperature of 5° C or higher.  
 (a) = Both AV and non-AV motors can be used for selection.

# Double Reduction Selection Tables: Y1,Y2,Y3,Y4,Y5,Y6

**1 HP**  
(0.75 kW)

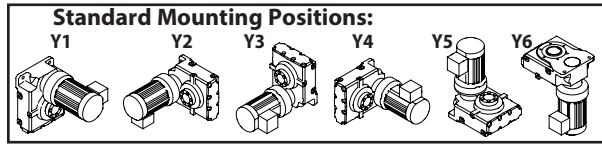

Dimension Pages:  
Single Reduction 3.80-3.85  
Double Reduction 3.86-3.91

Frequency	50 Hz	60 Hz
Input Speed	1450 RPM	1750 RPM
Number of Poles	4	

50Hz			60 Hz			Selection			VFD <sup>[1]</sup>
Output Speed (RPM)	Output Torque in-lbs (N·m)	Service Factor SF AGMA Class	Output Speed (RPM)	Output Torque in-lbs (N·m)	Service Factor SF AGMA Class	Motor Power Code	Base Frame Size Ratio		
0.741	78900 (8910)	0.42 -	0.894	65300 (7380)	0.51 -	1	<b>C614DB</b> 1957		
		0.73 -			1	<b>D616DA</b> 1957			
		1.01 I			1	<b>E617DA</b> 1957			
0.638	91600 (10300)	0.63 -	0.770	75900 (8570)	0.75 -	1	<b>D616DA</b> 2272		
		0.87 -			1	<b>E617DA</b> 2272			
0.567	103000 (11700)	0.56 -	0.684	85500 (9650)	0.67 -	1	<b>D616DA</b> 2559		
		0.77 -			1	<b>E617DA</b> 2559			
0.493	119000 (13400)	0.48 -	0.595	98300 (11100)	0.58 -	1	<b>D616DA</b> 2944		
		0.67 -			1	<b>E617DA</b> 2944			
0.413	142000 (16000)	0.56 -	0.499	117000 (13200)	0.68 -	1	<b>E617DA</b> 3511		
0.332	176000 (19900)	0.45 -	0.401	146000 (16500)	0.55 -	1	<b>E617DA</b> 4365		

# Double Reduction Selection Tables: Y1,Y2,Y3,Y4,Y5,Y6

**1.5 HP**  
(1.1 kW)

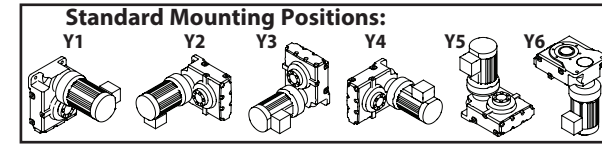

Dimension Pages:  
Single Reduction 3.80-3.85  
Double Reduction 3.86-3.91

Frequency	50 Hz	60 Hz
Input Speed	1450 RPM	1750 RPM
Number of Poles	4	

50Hz			60 Hz			Selection			VFD <sup>[1]</sup>
Output Speed (RPM)	Output Torque in-lbs (N·m)	Service Factor SF AGMA Class	Output Speed (RPM)	Output Torque in-lbs (N·m)	Service Factor SF AGMA Class	Motor Power Code	Base Frame Size Ratio		
3.98	21500 (2430)	0.77 -	4.81	17800 (2010)	0.93 -	1H	<b>B612DB</b> 364		
		1.45 II			1H	<b>C614DB</b> 364			
		1.53 II			1H	<b>C614DC</b> 364			
		2.66 III			1H	<b>D616DB</b> 364			
3.42	25000 (2830)	0.66 -	4.13	20700 (2340)	0.80 -	1H	<b>B612DB</b> 424		
		1.32 I			1H	<b>C614DB</b> 424			
		1.32 I			1H	<b>C614DC</b> 424			
		2.29 III			1H	<b>D616DB</b> 424			
		3.05 III			1H	<b>E617DB</b> 424			
		3.19 III			1H	<b>E617DC</b> 424			
2.90	29600 (3340)	0.56 -	3.50	24500 (2770)	0.67 -	1H	<b>B612DB</b> 501		
		1.12 I			1H	<b>C614DB</b> 501			
		1.45 II			1H	<b>D616DA</b> 501			
		1.94 II			1H	<b>D616DB</b> 501			
		2.70 III			1H	<b>E617DB</b> 501			
		2.70 III			1H	<b>E617DC</b> 501			
		3.26 III			1H	<b>E617DC</b> 501			
2.51	34100 (3860)	0.48 -	3.03	28300 (3200)	0.58 -	1H	<b>B612DB</b> 578		
		0.97 -			1H	<b>C614DB</b> 578			
		1.45 II			1H	<b>D616DA</b> 578			
		1.68 II			1H	<b>D616DB</b> 578			
		2.34 III			1H	<b>E617DB</b> 578			
2.12	40300 (4560)	0.82 -	2.56	33400 (3780)	0.99 -	1H	<b>C614DB</b> 683		
		1.42 II			1H	<b>D616DA</b> 683			
		1.42 II			1H	<b>D616DB</b> 683			
		1.98 II			1H	<b>E617DB</b> 683			
1.79	47800 (5400)	0.69 -	2.16	39600 (4470)	0.83 -	1H	<b>C614DB</b> 809		
		1.20 I			1H	<b>D616DA</b> 809			
		1.45 II			1H	<b>E617DA</b> 809			
		1.67 II			1H	<b>E617DB</b> 809			
1.52	56500 (6380)	0.58 -	1.83	46800 (5290)	0.71 -	1H	<b>C614DB</b> 956		
		1.01 I			1H	<b>D616DA</b> 956			
		1.41 II			1H	<b>E617DA</b> 956			
		1.41 II			1H	<b>E617DB</b> 956			
1.30	66000 (7460)	0.50 -	1.57	54700 (6180)	0.60 -	1H	<b>C614DB</b> 1117		
		0.87 -			1H	<b>D616DA</b> 1117			
		1.21 I			1H	<b>E617DA</b> 1117			

Notes: [1] Variable Frequency Drive (VFD) notes (see page 3.8 for Constant Torque Speed Ranges):  
 (-) = For Inverter Operation, starting condition may require ambient temperature of 5° C or higher.  
 (a) = Both AV and non-AV motors can be used for selection.

Notes: [1] Variable Frequency Drive (VFD) notes (see page 3.8 for Constant Torque Speed Ranges):  
 (-) = For Inverter Operation, starting condition may require ambient temperature of 5° C or higher.  
 (a) = Both AV and non-AV motors can be used for selection.



# Double Reduction Selection Tables: Y1,Y2,Y3,Y4,Y5,Y6

**1.5 HP**  
(1.1 kW)

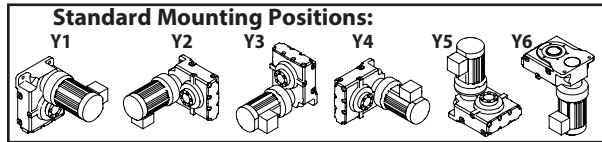

Dimension Pages:

Single Reduction	3.80-3.85
Double Reduction	3.86-3.91

Frequency	50 Hz	60 Hz
Input Speed	1450 RPM	1750 RPM
Number of Poles	4	

50Hz			60 Hz			Selection			VFD <sup>[1]</sup>
Output Speed (RPM)	Output Torque in-lbs (N·m)	Service Factor SF AGMA Class	Output Speed (RPM)	Output Torque in-lbs (N·m)	Service Factor SF AGMA Class	Motor Power Code	Base Frame Size	Ratio	
1.10	78000 (8810)	0.42 -	1.33	64600 (7300)	0.51 -	1H	<b>C614DB</b>	1320	
		0.73 -			1H	<b>D616DA</b>	1320		
		1.02 I			1H	<b>E617DA</b>	1320		
0.876	97900 (11100)	0.59 -	1.06	81100 (9160)	0.71 -	1H	<b>D616DA</b>	1656	
		0.82 -			1H	<b>E617DA</b>	1656		
0.741	116000 (13100)	0.50 -	0.894	95800 (10800)	0.60 -	1H	<b>D616DA</b>	1957	
		0.69 -			1H	<b>E617DA</b>	1957		
0.638	134000 (15200)	0.43 -	0.770	111000 (12600)	0.51 -	1H	<b>D616DA</b>	2272	
		0.60 -			1H	<b>E617DA</b>	2272		
0.567	151000 (17100)	0.53 -	0.684	125000 (14200)	0.64 -	1H	<b>E617DA</b>	2559	
0.493	174000 (19700)	0.46 -	0.595	144000 (16300)	0.55 -	1H	<b>E617DA</b>	2944	

# Double Reduction Selection Tables: Y1,Y2,Y3,Y4,Y5,Y6

**2 HP**  
(1.5 kW)

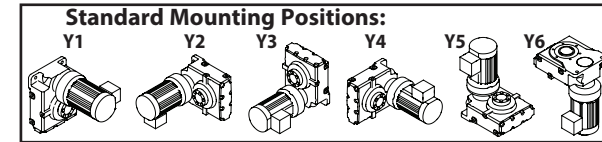

Dimension Pages:

Single Reduction	3.80-3.85
Double Reduction	3.86-3.91

Frequency	50 Hz	60 Hz
Input Speed	1450 RPM	1750 RPM
Number of Poles	4	

50Hz			60 Hz			Selection			VFD <sup>[1]</sup>
Output Speed (RPM)	Output Torque in-lbs (N·m)	Service Factor SF AGMA Class	Output Speed (RPM)	Output Torque in-lbs (N·m)	Service Factor SF AGMA Class	Motor Power Code	Base Frame Size	Ratio	
3.98	29300 (3320)	0.56 -	4.81	24300 (2750)	0.68 -	2	<b>B612DB</b>	364	
		1.07 I			2	<b>C614DB</b>	364		
		1.13 I			2	<b>C614DC</b>	364		
		1.95 II			2	<b>D616DB</b>	364		
		1.95 II			2	<b>D616DC</b>	364		
		2.72 III			2	<b>E617DC</b>	364		
3.42	34100 (3860)	0.48 -	4.13	28300 (3200)	0.58 -	2	<b>B612DB</b>	424	
		0.97 -			2	<b>C614DB</b>	424		
		0.97 -			2	<b>C614DC</b>	424		
		1.68 II			2	<b>D616DB</b>	424		
		2.24 III			2	<b>E617DB</b>	424		
		2.34 III			2	<b>E617DC</b>	424		
2.90	40300 (4560)	0.82 -	3.50	33400 (3780)	0.99 -	2	<b>C614DB</b>	501	
		1.07 I			2	<b>D616DA</b>	501		
		1.42 II			2	<b>D616DB</b>	501		
		1.98 II			2	<b>E617DB</b>	501		
		1.98 II			2	<b>E617DC</b>	501		
2.51	46600 (5260)	0.71 -	3.03	38600 (4360)	0.86 -	2	<b>C614DB</b>	578	
		1.07 I			2	<b>D616DA</b>	578		
		1.23 I			2	<b>D616DB</b>	578		
		1.72 II			2	<b>E617DB</b>	578		
2.12	55000 (6220)	0.60 -	2.56	45600 (5150)	0.72 -	2	<b>C614DB</b>	683	
		1.04 I			2	<b>D616DA</b>	683		
		1.04 I			2	<b>D616DB</b>	683		
		1.45 II			2	<b>E617DB</b>	683		
1.79	65200 (7360)	0.51 -	2.16	54000 (6100)	0.61 -	2	<b>C614DB</b>	809	
		0.88 -			2	<b>D616DA</b>	809		
		1.07 I			2	<b>E617DA</b>	809		
		1.23 I			2	<b>E617DB</b>	809		
1.52	77000 (8700)	0.43 -	1.83	63800 (7210)	0.52 -	2	<b>C614DB</b>	956	
		0.74 -			2	<b>D616DA</b>	956		
		1.04 I			2	<b>E617DA</b>	956		
		1.04 I			2	<b>E617DB</b>	956		
1.30	90000 (10200)	0.64 -	1.57	74600 (8430)	0.77 -	2	<b>D616DA</b>	1117	
		0.89 -			2	<b>E617DA</b>	1117		
1.10	106000 (12000)	0.54 -	1.33	88100 (9960)	0.65 -	2	<b>D616DA</b>	1320	
		0.75 -			2	<b>E617DA</b>	1320		

**Notes:** [1] Variable Frequency Drive (VFD) notes (see page 3.8 for Constant Torque Speed Ranges):  
 (-) = For Inverter Operation, starting condition may require ambient temperature of 5° C or higher.  
 (a) = Both AV and non-AV motors can be used for selection.

**Notes:** [1] Variable Frequency Drive (VFD) notes (see page 3.8 for Constant Torque Speed Ranges):  
 (-) = For Inverter Operation, starting condition may require ambient temperature of 5° C or higher.  
 (a) = Both AV and non-AV motors can be used for selection.

# Double Reduction Selection Tables: Y1,Y2,Y3,Y4,Y5,Y6

**2 HP**  
(1.5 kW)

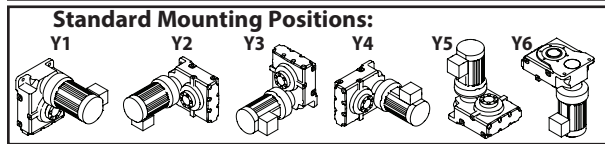

Dimension Pages:  
Single Reduction 3.80-3.85  
Double Reduction 3.86-3.91

Frequency	50 Hz	60 Hz
Input Speed	1450 RPM	1750 RPM
Number of Poles	4	

50Hz			60 Hz			Selection			VFD <sup>[1]</sup>
Output Speed (RPM)	Output Torque in-lbs (N·m)	Service Factor SF AGMA Class	Output Speed (RPM)	Output Torque in-lbs (N·m)	Service Factor SF AGMA Class	Motor Power Code	Frame Size	Ratio	
0.876	133000 (15100)	0.43 -	1.06	111000 (12500)	0.52 -	2	<b>D616DA</b>	1656	
		0.60 -			0.72 -	2	<b>E617DA</b>	1656	
0.741	158000 (17800)	0.51 -	0.894	131000 (14800)	0.61 -	2	<b>E617DA</b>	1957	
0.638	183000 (20700)	0.44 -	0.770	152000 (17100)	0.53 -	2	<b>E617DA</b>	2272	

# Double Reduction Selection Tables: Y1,Y2,Y3,Y4,Y5,Y6

**3 HP**  
(2.2 kW)

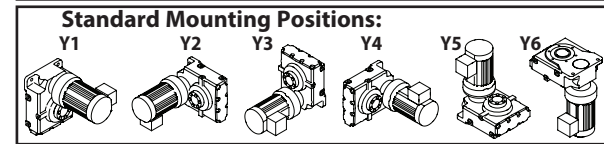

Dimension Pages:  
Single Reduction 3.80-3.85  
Double Reduction 3.86-3.91

Frequency	50 Hz	60 Hz
Input Speed	1450 RPM	1750 RPM
Number of Poles	4	

50Hz			60 Hz			Selection			VFD <sup>[1]</sup>
Output Speed (RPM)	Output Torque in-lbs (N·m)	Service Factor SF AGMA Class	Output Speed (RPM)	Output Torque in-lbs (N·m)	Service Factor SF AGMA Class	Motor Power Code	Frame Size	Ratio	
3.98	43000 (4860)	0.73 -	4.81	35700 (4030)	0.73 -	3	<b>C614DB</b>	364	
		0.77 -			0.93 -	3	<b>C614DC</b>	364	
		1.33 I			1.53 II	3	<b>D616DB</b>	364	
		1.33 I			1.61 II	3	<b>D616DC</b>	364	
		1.86 II			2.24 III	3	<b>E617DC</b>	364	
3.42	50100 (5660)	0.66 -	4.13	41500 (4690)	0.73 -	3	<b>C614DB</b>	424	
		0.66 -			0.80 -	3	<b>C614DC</b>	424	
		1.14 I			1.38 I	3	<b>D616DB</b>	424	
		1.53 II			1.53 II	3	<b>E617DB</b>	424	
		1.60 II			1.93 II	3	<b>E617DC</b>	424	
2.90	59200 (6690)	0.56 -	3.50	49000 (5540)	0.67 -	3	<b>C614DB</b>	501	
		0.73 -			0.73 -	3	<b>D616DA</b>	501	
		0.97 -			1.17 I	3	<b>D616DB</b>	501	
		1.35 I			1.53 II	3	<b>E617DB</b>	501	
		1.35 I			1.63 II	3	<b>E617DC</b>	501	
2.51	68300 (7720)	0.48 -	3.03	56600 (6390)	0.58 -	3	<b>C614DB</b>	578	
		0.73 -			0.73 -	3	<b>D616DA</b>	578	
		0.84 -			1.01 I	3	<b>D616DB</b>	578	
		1.17 I			1.41 II	3	<b>E617DB</b>	578	
2.12	80700 (9120)	0.71 -	2.56	66900 (7550)	0.73 -	3	<b>D616DA</b>	683	
		0.71 -			0.86 -	3	<b>D616DB</b>	683	
		0.99 -			1.20 I	3	<b>E617DB</b>	683	
1.79	95600 (10800)	0.60 -	2.16	79200 (8950)	0.72 -	3	<b>D616DA</b>	809	
		0.73 -			0.73 -	3	<b>E617DA</b>	809	
		0.84 -			1.01 I	3	<b>E617DB</b>	809	
1.52	113000 (12800)	0.51 -	1.83	93600 (10600)	0.61 -	3	<b>D616DA</b>	956	
		0.71 -			0.73 -	3	<b>E617DA</b>	956	
		0.71 -			0.85 -	3	<b>E617DB</b>	956	
1.30	132000 (14900)	0.43 -	1.57	109000 (12400)	0.52 -	3	<b>D616DA</b>	1117	
		0.61 -			0.73 -	3	<b>E617DA</b>	1117	
1.10	156000 (17600)	0.51 -	1.33	129000 (14600)	0.62 -	3	<b>E617DA</b>	1320	

Notes: [1] Variable Frequency Drive (VFD) notes (see page 3.8 for Constant Torque Speed Ranges):  
(-) = For Inverter Operation, starting condition may require ambient temperature of 5° C or higher.  
(a) = Both AV and non-AV motors can be used for selection.

Notes: [1] Variable Frequency Drive (VFD) notes (see page 3.8 for Constant Torque Speed Ranges):  
(-) = For Inverter Operation, starting condition may require ambient temperature of 5° C or higher.  
(a) = Both AV and non-AV motors can be used for selection.

# Double Reduction Selection Tables: Y1,Y2,Y3,Y4,Y5,Y6

**5 HP  
(3.7 kW)**

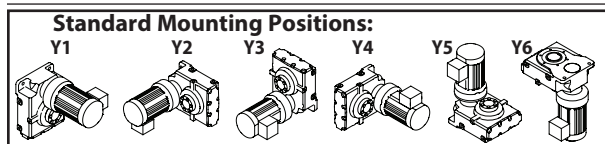

Dimension Pages:  
Single Reduction 3.80-3.85  
Double Reduction 3.86-3.91

Frequency	50 Hz	60 Hz
Input Speed	1450 RPM	1750 RPM
Number of Poles	4	

50Hz			60 Hz			Selection			VFD <sup>[1]</sup>				
Output Speed (RPM)	Output Torque		Service Factor	AGMA Class	Output Speed (RPM)	Output Torque		Base					
	in-lbs	(N·m)				in-lbs	(N·m)	SF	AGMA Class	Motor Power Code	Frame Size	Ratio	
3.98	72400	(8180)	0.79	-	4.81	60000	(6780)	0.95	-	5	<b>D616DC</b>	364	
			1.10	I				5	<b>E617DC</b>	364			
3.42	84200	(9520)	0.68	-	4.13	69800	(7880)	0.82	-	5	<b>D616DC</b>	424	
			0.95	-				5	<b>E617DC</b>	424			
2.90	99500	(11200)	0.58	-	3.50	82500	(9320)	0.69	-	5	<b>D616DC</b>	501	
			0.80	-				5	<b>E617DC</b>	501			
2.51	115000	(13000)	0.50	-	3.03	95200	(10800)	0.60	-	5	<b>D616DC</b>	578	
			0.70	-				5	<b>E617DC</b>	578			
2.12	136000	(15300)	0.42	-	2.56	112000	(12700)	0.51	-	5	<b>D616DC</b>	683	
			0.59	-				5	<b>E617DC</b>	683			
1.79	161000	(18200)	0.50	-	2.16	133000	(15100)	0.60	-	5	<b>E617DC</b>	809	
			0.42	-				5	<b>E617DC</b>	956			

# Double Reduction Selection Tables: Y1,Y2,Y3,Y4,Y5,Y6

**7.5 HP  
(5.5 kW)**

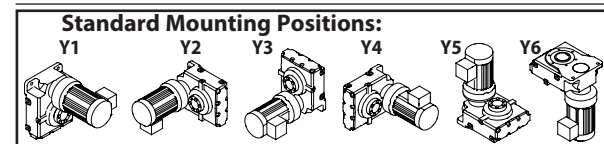

Dimension Pages:  
Single Reduction 3.80-3.85  
Double Reduction 3.86-3.91

Frequency	50 Hz	60 Hz
Input Speed	1450 RPM	1750 RPM
Number of Poles	4	

50Hz			60 Hz			Selection			VFD <sup>[1]</sup>				
Output Speed (RPM)	Output Torque		Service Factor	AGMA Class	Output Speed (RPM)	Output Torque		Base					
	in-lbs	(N·m)				in-lbs	(N·m)	SF	AGMA Class	Motor Power Code	Frame Size	Ratio	
3.98	108000	(12200)	0.53	-	4.81	89200	(10100)	0.64	-	8	<b>D616DC</b>	364	
			0.74	-				8	<b>E617DC</b>	364			
3.42	125000	(14100)	0.46	-	4.13	104000	(11700)	0.55	-	8	<b>D616DC</b>	424	
			0.64	-				8	<b>E617DC</b>	424			
2.90	148000	(16700)	0.54	-	3.50	123000	(13900)	0.65	-	8	<b>E617DC</b>	501	
			0.47	-				8	<b>E617DC</b>	578			
2.51	171000	(19300)	0.47	-	3.03	141000	(16000)	0.57	-	8	<b>E617DC</b>	578	

**Notes:** [1] Variable Frequency Drive (VFD) notes (see page 3.8 for Constant Torque Speed Ranges):  
 (-) = For Inverter Operation, starting condition may require ambient temperature of 5° C or higher.  
 (a) = Both AV and non-AV motors can be used for selection.

**Notes:** [1] Variable Frequency Drive (VFD) notes (see page 3.8 for Constant Torque Speed Ranges):  
 (-) = For Inverter Operation, starting condition may require ambient temperature of 5° C or higher.  
 (a) = Both AV and non-AV motors can be used for selection.

Dimensions

Dimensions

Single Reduction
EHYM-Z6090Y~A6105Y

Single Reduction
EHYM-Z6090Y~A6105Y (cont.)

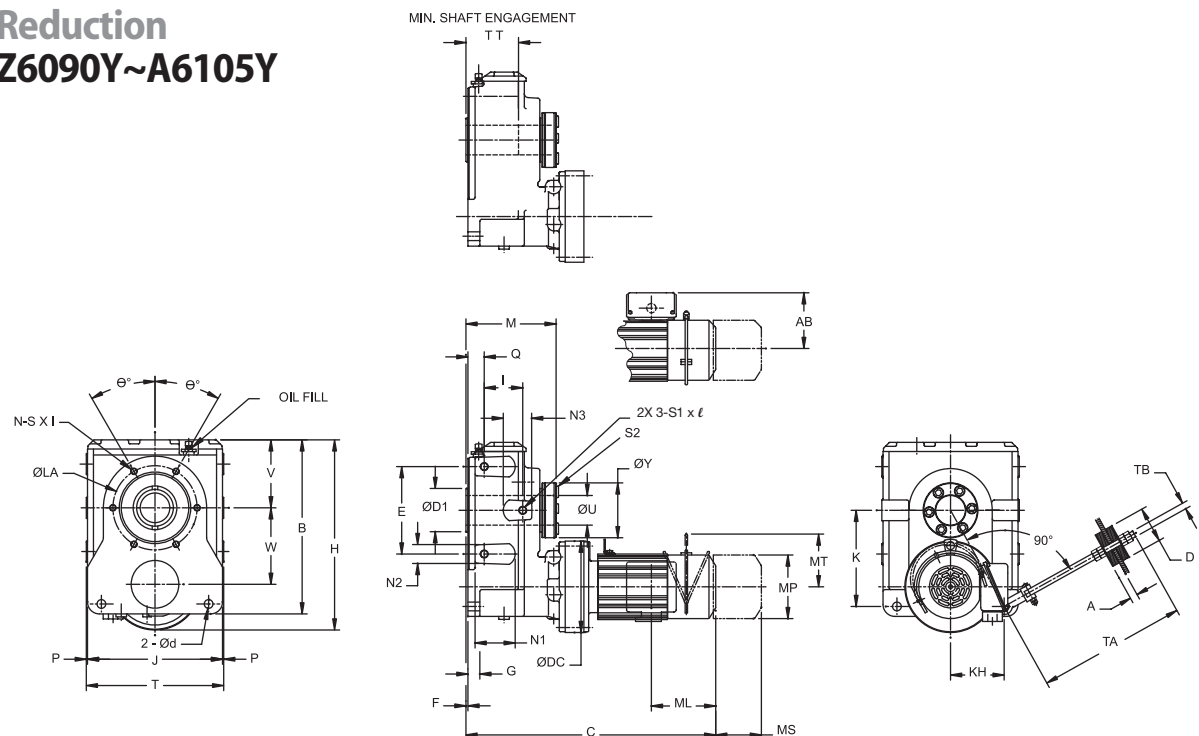

All dimensions are in inches (mm).

Table with dimensions: Model, B, E, F, G, H, I, J, K, M, P, Q, T, TT, Max (Std), Min. Includes models Z609 and A610.

Table with dimensions: Model, V, W, ØY, Ød, ØD1, ØDC, KH, N1, N2, N3, S2, TA, A, D, TB. Includes models Z609 and A610.

All dimensions are in inches (mm)

Large table with columns: Frames, HPxP (kW x P), Model, Without Brake (C, AB, ML, MP, Wt. lb (kg)), With Brake (C, AB, ML, MP, MS, MT, Wt. lb (kg)). Lists models from EHYM01-Z6095Y to EHYM2-Z6095Y-EP.

Large table with columns: Frames, HPxP (kW x P), Model, Without Brake (C, AB, ML, MP, Wt. lb (kg)), With Brake (C, AB, ML, MP, MS, MT, Wt. lb (kg)). Lists models from EHYM02-A6105Y to EHYM3-A6105Y-EP.

Notes [1]: DM Dimension Symbol ø = Round Fan Cover
DM Dimension Symbol = Square Fan Cover

# Dimensions

## Single Reduction EHYM-B6120Y~C6145Y

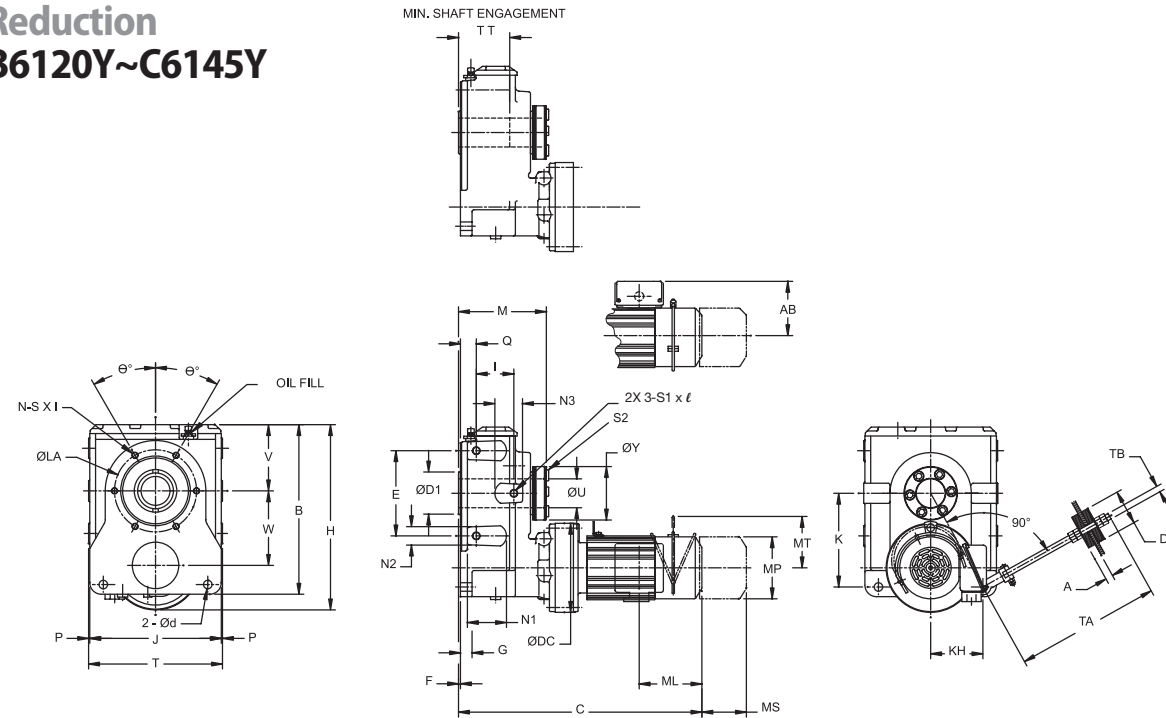

All dimensions are in inches (mm).

Model	B	E	F	G	H	I	J	K	M	P	Q	T	TT	ØU	
														Max (Std)	Min
B612	14.45 (367)	7.48 (190)	0.20 (5)	0.98 (35)	16.10 (409)	3.39 (86)	11.42 (290)	7.97 (202.5)	7.64 (194)	0.12 (3)	1.22 (31)	11.65 (296)	5.63 (143)	2-7/16 (61.9)	1-15/16 (49.2)
C614	17.24 (438)	8.66 (220)		1.18 (30)	18.84 (479)	3.82 (97)	13.39 (340)	9.53 (242)	9.17 (233)		1.61 (41)	13.62 (346)	7.32 (186)	2-15/16 (74.6)	2-3/16 (55.6)

Model	V	W	ØY	Ød	ØD1	ØDC	KH	N1	N2	N3	S2	TA	A	D	TB
B612	5.69 (144.5)	6.40 (163)	4.49 (114)	0.71 (18)	3.94 (100)	8.03 (204)	4.33 (110)	1.34 (34)	1.26 (32)	-	M12	17.87 (454)	0.63 (16)	2.36 (60)	M20
C614	6.73 (171)	7.58 (193)	5.43 (138)	0.87 (22)	4.33 (110)	9.06 (230)	5.31 (135)	3.98 (101)	2.05 (52)	2.83 (72)	M16	18.37 (467)	0.75 (19)	3.54 (90)	M24

# Dimensions

## Single Reduction EHYM-B6120Y~C6145Y (cont.)

All dimensions are in inches (mm).

Frames	HPxP (kW x P)	Model	Without Brake					With Brake							
			C	AB	ML	MP [1]	Wt	C	AB	ML	MP [1]	MS	MT	Wt. lb (kg)	
B6120, B6125	1/2 x 4 (0.4 x 4)	EHYM05-B6125Y	17.07 (434)	4.63 (118)	2.32 (59)	ø4.88 (ø124)	165 (75)	18.33 (466)	4.63 (118)	3.58 (91)	ø4.88 (ø124)	2.40 (61)	-	-	168 (77)
	3/4 x 4 (0.55 x 4)	EHYM08-B6125Y	18.48 (470)	5.67 (144)	3.82 (97)	ø5.94 (ø151)	170 (77)	20.18 (513)	5.67 (144)	5.51 (140)	ø5.94 (ø151)	3.66 (93)	3.94 (100)	175 (80)	
	1/2 x 4 (0.4 x 4)	EHYM05-B6125Y-AV					172 (78)							178 (81)	
	3/4 x 4 (0.55 x 4)	EHYM08-B6125Y-AV	19.78 (503)	5.86 (149)	3.94 (100)	ø6.30 (ø160)	178 (81)	22.22 (565)	5.86 (149)	6.38 (162)	ø6.30 (ø160)	4.53 (115)	4.29 (109)	189 (86)	
	1 x 4 (0.75 x 4)	EHYM1-B6125Y-EP	20.22 (514)	5.98 (152)	3.82 (97)	6.22 (158)	183 (83)	22.72 (577)	5.98 (152)	6.32 (161)	6.22 (158)	4.80 (122)	4.25 (108)	193 (88)	
	1.5 x 4 (1.1 x 4)	EHYM1H-B6125Y-EP	21.28 (541)	6.16 (156)	3.82 (97)	6.57 (167)	190 (86)	24.02 (610)	6.16 (156)	6.56 (167)	6.57 (167)	5.04 (128)	4.61 (117)	201 (92)	
	2 x 4 (1.5 x 4)	EHYM2-B6125Y-EP					193 (88)							204 (93)	
	3 x 4 (2.2 x 4)	EHYM3-B6125Y-EP	20.69 (526)	6.71 (170)	4.53 (115)	7.24 (184)	206 (94)	23.76 (604)	6.71 (170)	7.60 (193)	7.24 (184)	5.43 (138)	5.04 (128)	222 (101)	
	5 x 4 (3.7 x 4)	EHYM5-B6125Y-EP	22.15 (563)	7.34 (186)	4.65 (118)	8.74 (222)	231 (105)	25.71 (653)	7.34 (186)	8.21 (209)	8.74 (222)	6.02 (153)	6.30 (160)	255 (116)	
	7.5 x 4 (5.5 x 4)	EHYM8-B6125Y-EP	265 (120)				274 (696)							289 (131)	
10 x 4 (7.5 x 4)	EHYM10-B6125Y-EP	25.57 (650)	9.04 (230)	5.43 (138)	10.24 (260)	293 (133)	29.70 (755)	9.04 (230)	9.57 (243)	10.24 (260)	7.44 (189)	7.32 (186)	337 (153)		

Frames	HPxP (kW x P)	Model	Without Brake					With Brake						
			C	AB	ML	MP [1]	Wt	C	AB	ML	MP [1]	MS	MT	Wt. lb (kg)
C6140, C6145	3/4 x 4 (0.55 x 4)	EHYM08-C6145Y	21.00 (534)	5.67 (144)	3.82 (97)	ø5.94 (ø151)	272 (124)	22.70 (577)	5.67 (144)	5.51 (140)	ø5.94 (ø151)	3.66 (93)	3.94 (100)	278 (126)
	3/4 x 4 (0.55 x 4)	EHYM08-C6145Y-AV	22.30 (567)	5.86 (149)	3.94 (100)		281 (128)							24.74 (629)
	1 x 4 (0.75 x 4)	EHYM1-C6145Y-EP	22.74 (578)	5.98 (152)	3.82 (97)	6.22 (158)	285 (130)	25.24 (641)	5.98 (152)	6.32 (161)	6.22 (158)	4.80 (122)	4.25 (108)	295 (134)
	1.5 x 4 (1.1 x 4)	EHYM1H-C6145Y-EP	23.80 (605)	6.16 (156)			292 (133)							26.54 (674)
	2 x 4 (1.5 x 4)	EHYM2-C6145Y-EP	295 (134)	307 (147)										
	3 x 4 (2.2 x 4)	EHYM3-C6145Y-EP	23.21 (590)	6.71 (170)	4.53 (115)	7.24 (184)	307 (139)	26.28 (668)	6.71 (170)	7.60 (193)	7.24 (184)	5.43 (138)	5.04 (128)	323 (147)
	5 x 4 (3.7 x 4)	EHYM5-C6145Y-EP	24.47 (622)	7.34 (186)	4.65 (118)	8.74 (222)	331 (150)	28.03 (712)	7.34 (186)	8.21 (209)	8.74 (222)	6.02 (153)	6.30 (160)	355 (161)
	7.5 x 4 (5.5 x 4)	EHYM8-C6145Y-EP	365 (166)				29.72 (755)							389 (177)
	10 x 4 (7.5 x 4)	EHYM10-C6145Y-EP	27.66 (703)	9.04 (230)	5.43 (138)	10.24 (260)	392 (178)	31.79 (808)	9.04 (230)	9.57 (243)	10.24 (260)	7.44 (189)	7.32 (186)	436 (198)
	15 x 4 (11 x 4)	EHYM15-C6145Y-EP	404 (184)				34.23 (870)							449 (204)
20 x 4 (15 x 4)	EHYM20-C6145Y-EP	32.54 (827)	10.26 (261)	7.01 (178)	ø12.49 (ø317)	485 (220)	37.83 (961)	10.26 (261)	12.30 (313)	ø12.61 (ø320)	9.53 (242)	-	571 (259)	

Notes [1]: DM Dimension Symbol ø = Round Fan Cover  
DM Dimension Symbol = Square Fan Cover

# Dimensions

# Dimensions

## Single Reduction EHYM-D6160Y~E6175Y

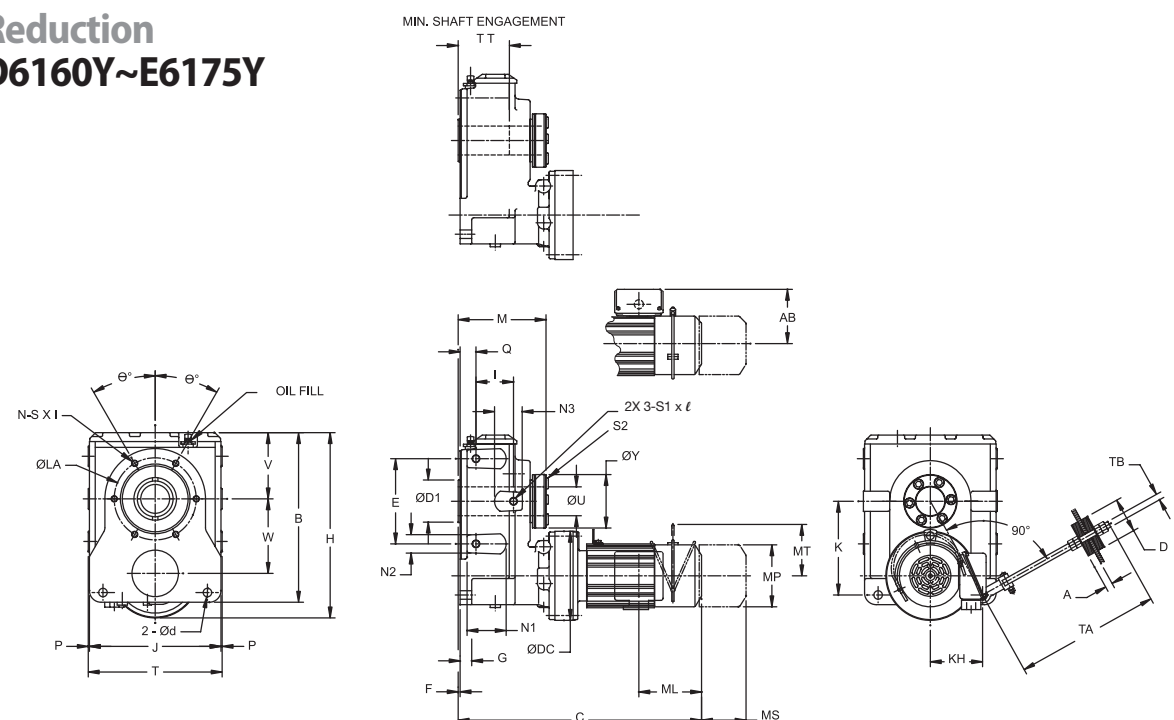

All dimensions are in inches.

Model	B	E	F	G	H	I	J	K	M	P	Q	T	TT	ØU	
														Max (Std)	Min
D616	21.22 (539)	9.84 (250)	0.28 (7)	1.38 (35)	23.94 (608)	4.49 (114)	16.77 (426)	11.54 (293)	10.20 (259)	0.20 (5)	1.77 (45)	17.17 (436)	8.03 (204)	3-7/16 (87.3)	2-7/16 (65.1)
E617	24.02 (610)	11.81 (300)		1.77 (45)	26.85 (682)	5.00 (127)	18.90 (480)	13.07 (332)	10.98 (279)		1.97 (50)	19.29 (490)	8.82 (224)	3-15/16 (100)	2-15/16 (74.6)

Model	V	W	ØY	Ød	ØD1	ØDC	KH	N1	N2	N3	S2	TA	A	D	TB
D616	8.43 (214)	9.61 (244)	5.98 (152)	1.02 (26)	5.12 (130)	11.81 (300)	6.38 (162)	3.62 (92)	2.36 (60)	3.62 (92)	M16	19.50 (495)	0.75 (19)	3.54 (90)	M24
E617	9.45 (240)	10.71 (272)	6.69 (170)	1.30 (33)	5.91 (150)	13.39 (340)	7.09 (180)	3.82 (97)	2.44 (62)	3.94 (100)		20.25 (514)			

## Single Reduction EHYM-D6160Y~E6175Y

All dimensions are in inches (mm)

Frames	HPxP (kW x P)	Model	Without Brake					With Brake						
			C	AB	ML	MP <sup>[1]</sup>	Wt	C	AB	ML	MP <sup>[1]</sup>	MS	MT	Wt. lb (kg)
D6160, D6165	1 x 4 (0.75 x 4)	EHYM1-D6165Y-EP	23.29 (592)	5.98 (152)	3.82 (97)	6.22 (158)	482 (219)	25.79 (655)	5.98 (152)	6.32 (161)	6.22 (158)	4.80 (122)	4.25 (108)	492 (224)
	1.5 x 4 (1.1 x 4)	EHYM1H-D6165Y-EP	24.35 (619)	6.16 (156)		6.57 (167)	490 (222)	27.09 (688)	6.16 (156)	6.56 (167)	6.57 (167)	5.04 (128)	4.61 (117)	501 (228)
	2 x 4 (1.5 x 4)	EHYM2-D6165Y-EP				493 (224)							504 (229)	
	3 x 4 (2.2 x 4)	EHYM3-D6165Y-EP	24.09 (612)	6.71 (170)	4.53 (115)	7.24 (184)	503 (228)	27.17 (690)	6.71 (170)	7.60 (193)	7.24 (184)	5.43 (138)	5.04 (128)	519 (236)
	5 x 4 (3.7 x 4)	EHYM5-D6165Y-EP	24.96 (634)	7.34 (186)	4.65 (118)	8.74 (222)	528 (240)	28.52 (725)	7.34 (186)	8.21 (209)	8.74 (222)	6.02 (153)	6.30 (160)	551 (250)
	7.5 x 4 (5.5 x 4)	EHYM8-D6165Y-EP	26.65 (677)				561 (255)	30.22 (768)						585 (266)
	10 x 4 (7.5 x 4)	EHYM10-D6165Y-EP	27.01 (686)	9.04 (230)	5.43 (138)	10.24 (260)	589 (268)	31.14 (791)	9.04 (230)	9.57 (243)	10.24 (260)	7.44 (189)	7.32 (186)	634 (288)
	15 x 4 (11 x 4)	EHYM15-D6165Y-EP	29.45 (748)				602 (273)	33.58 (853)						646 (293)
	20 x 4 (15 x 4)	EHYM20-D6165Y-EP	31.06 (789)	10.26 (261)	7.01 (178)	ø12.49 (ø317)	685 (311)	36.36 (924)	10.26 (261)	12.30 (313)	ø12.61 (ø320)	9.53 (242)	-	771 (350)
	25 x 4 (18.5 x 4)	EHYM25-D6165Y-EP	33.86 (860)	13.39 (340)	9.06 (230)	ø15.12 (ø384)	963 (437)	40.71 (1034)	13.39 (340)	15.91 (404)	ø15.28 (ø388)	12.13 (308)	-	1060 (481)
30 x 4 (22 x 4)	EHYM30-D6165Y-EP													

Frames	HPxP (kW x P)	Model	Without Brake					With Brake						
			C	AB	ML	MP <sup>[1]</sup>	Wt	C	AB	ML	MP <sup>[1]</sup>	MS	MT	Wt. lb (kg)
E6170, E6175	3 x 4 (2.2 x 4)	EHYM3-E6175Y-EP	27.20 (691)	6.71 (170)	4.53 (115)	7.24 (184)	675 (306)	30.28 (769)	6.71 (170)	7.60 (193)	7.24 (184)	5.43 (138)	5.04 (128)	692 (314)
	5 x 4 (3.7 x 4)	EHYM5-E6175Y-EP	28.27 (718)	7.34 (186)	4.65 (118)	8.74 (222)	699 (317)	31.83 (809)	7.34 (186)	8.21 (209)	8.74 (222)	6.02 (153)	6.30 (160)	722 (328)
	7.5 x 4 (5.5 x 4)	EHYM8-E6175Y-EP	29.96 (761)				733 (333)	33.52 (852)						756 (343)
	10 x 4 (7.5 x 4)	EHYM10-E6175Y-EP	30.79 (782)	9.04 (230)	5.43 (138)	10.24 (260)	761 (346)	34.92 (887)	9.04 (230)	9.57 (243)	10.24 (260)	7.44 (189)	7.32 (186)	806 (366)
	15 x 4 (11 x 4)	EHYM15-E6175Y-EP	33.23 (844)				774 (351)	37.36 (949)						818 (371)
	20 x 4 (15 x 4)	EHYM20-E6175Y-EP	35.94 (913)	10.26 (261)	7.01 (178)	ø12.49 (ø317)	855 (388)	41.24 (1048)	10.26 (261)	12.30 (313)	ø12.61 (ø320)	9.53 (242)	-	941 (427)
	25 x 4 (18.5 x 4)	EHYM25-E6175Y-EP	40.12 (1019)	13.39 (340)	9.06 (230)	ø15.12 (ø384)	1134 (515)	46.97 (1193)	13.39 (340)	15.91 (404)	ø15.28 (ø388)	12.13 (308)	-	1231 (559)
	30 x 4 (22 x 4)	EHYM30-E6175Y-EP					1247 (566)	51.85 (1317)						1344 (610)
	40 x 4 (30 x 4)	EHYM40-E6175Y-EP	45.00 (1143)											

Notes [1]: DM Dimension Symbol ø = Round Fan Cover  
DM Dimension Symbol = Square Fan Cover

# Dimensions

## Double Reduction EHYM-Z609DAY~A610DAY

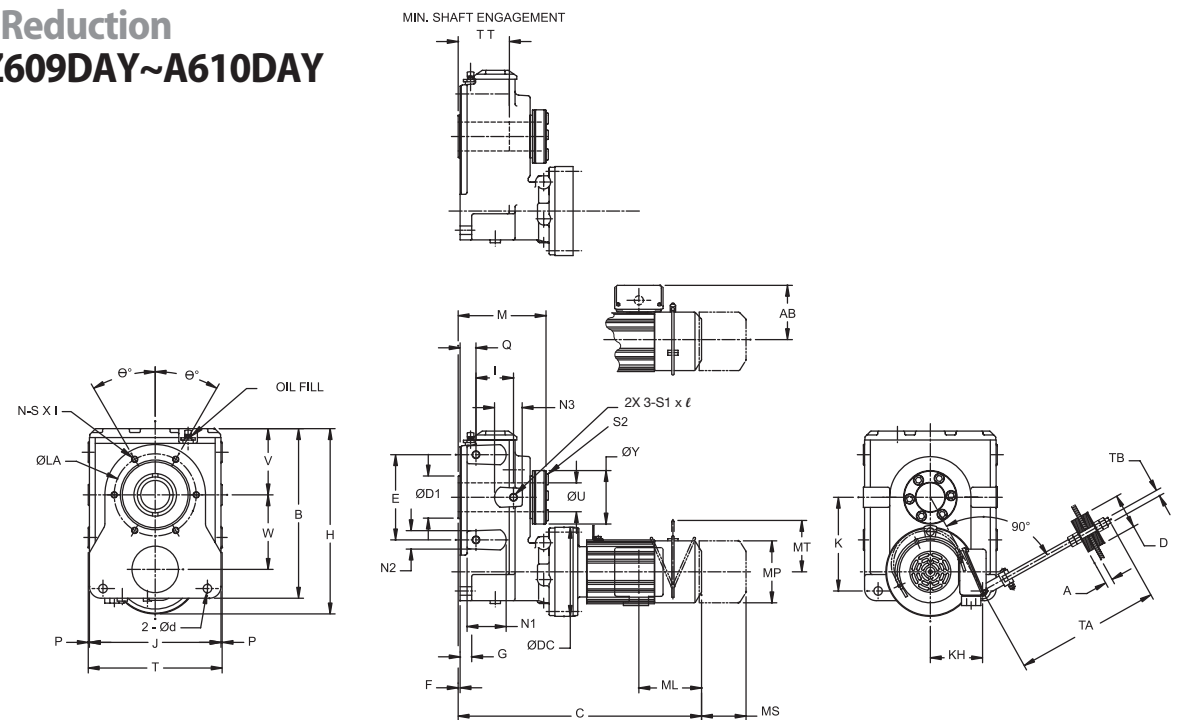

All dimensions are in inches (mm)

Model	B	E	F	G	H	I	J	K	M	P	Q	T	TT	ØU	
														Max (Std)	Min
Z609DA	11.00 (279.5)	5.51 (140)	0.20 (5)	0.79 (20)	11.87 (301)	2.20 (56)	8.31 (211)	6.18 (157)	6.06 (154)	0.12 (3)	1.06 (27)	8.54 (217)	4.43 (113)	1-7/16 (36.5)	1-3/16 (30.2)
A610DA	11.83 (300.5)	5.91 (150)			12.70 (323)	2.60 (66)	9.17 (233)	6.44 (163.5)	6.61 (168)		1.14 (29)	9.41 (239)	4.96 (126)	2-3/16 (55.6)	1-11/16 (42.9)

Model	V	W	ØY	Ød	ØD1	ØDC	KH	N1	N2	N3	S2	TA	A	D	TB
Z609DA	4.23 (107.4)	4.69 (119)	3.23 (82)	0.55 (14)	2.56 (65)	5.91 (150)	3.54 (90)	1.02 (26)	1.02 (26)	-	M10	17.50 (445)	0.63 (16)	2.36 (60)	M20
A610DA	4.61 (117)	5.14 (131)	4.09 (104)	0.71 (18)	3.35 (85)		3.74 (95)	1.10 (28)	1.10 (28)						

# Dimensions

## Double Reduction EHYM-Z609DAY~A610DAY

All dimensions are in inches (mm)

Frames	HPxP (kW x P)	Model	Without Brake					With Brake						
			C	AB	ML	MP <sup>[1]</sup>	Wt	C	AB	ML	MP <sup>[1]</sup>	MS	MT	Wt. lb (kg)
Z609DA	1/8 x 4 (0.1 x 4)	EHYM01-Z609DAY	13.92 (354)	4.63 (118)	1.38 (35)	ø4.69 (ø119)	72 (33)	15.30 (389)	4.63 (118)	2.76 (70)	ø4.88 (ø124)	1.93 (49)	-	75 (34)
	1/4 x 4 (0.2 x 4)	EHYM02-Z609DAY	15.57 (396)		2.32 (59)	ø4.88 (ø124)	74 (34)	16.83 (428)		3.58 (91)		2.40 (61)		77 (35)
	1/3 x 4 (0.25 x 4)	EHYM03-Z609DAY												
	1/8 x 4 (0.1 x 4)	EHYM01-Z609DAY-AV												
	1/4 x 4 (0.2 x 4)	EHYM02-Z609DAY-AV	16.36 (416)		ø4.88 (ø124)	77 (35)	17.62 (448)	80 (36)						
1/3 x 4 (0.25 x 4)	EHYM03-Z609DAY-AV													

Frames	HPxP (kW x P)	Model	Without Brake					With Brake						
			C	AB	ML	MP <sup>[1]</sup>	Wt	C	AB	ML	MP <sup>[1]</sup>	MS	MT	Wt. lb (kg)
A610DA	1/8 x 4 (0.1 x 4)	EHYM01-A610DAY	15.06 (383)	4.63 (118)	1.38 (35)	ø4.69 (ø119)	97 (44)	16.44 (418)	4.63 (118)	2.76 (70)	ø4.88 (ø124)	1.93 (49)	-	100 (46)
	1/4 x 4 (0.2 x 4)	EHYM02-A610DAY	16.71 (425)		2.32 (59)	ø4.88 (ø124)	99 (45)	17.97 (457)		3.58 (91)		2.40 (61)		102 (46)
	1/3 x 4 (0.25 x 4)	EHYM03-A610DAY												
	1/2 x 4 (0.4 x 4)	EHYM05-A610DAY	17.50 (445)		102 (46)	18.76 (477)	105 (48)							
	1/8 x 4 (0.1 x 4)	EHYM01-A610DAY-AV	16.71 (425)		ø4.69 (ø119)	99 (45)	17.97 (457)	102 (46)						
	1/4 x 4 (0.2 x 4)	EHYM02-A610DAY-AV												
1/3 x 4 (0.25 x 4)	EHYM03-A610DAY-AV	17.50 (445)	ø4.88 (ø124)	102 (46)	18.76 (477)	105 (48)								

Notes [1]: DM Dimension Symbol ø = Round Fan Cover  
DM Dimension Symbol = Square Fan Cover

# Dimensions

## Double Reduction EHYM-B612DAY~C614DBY

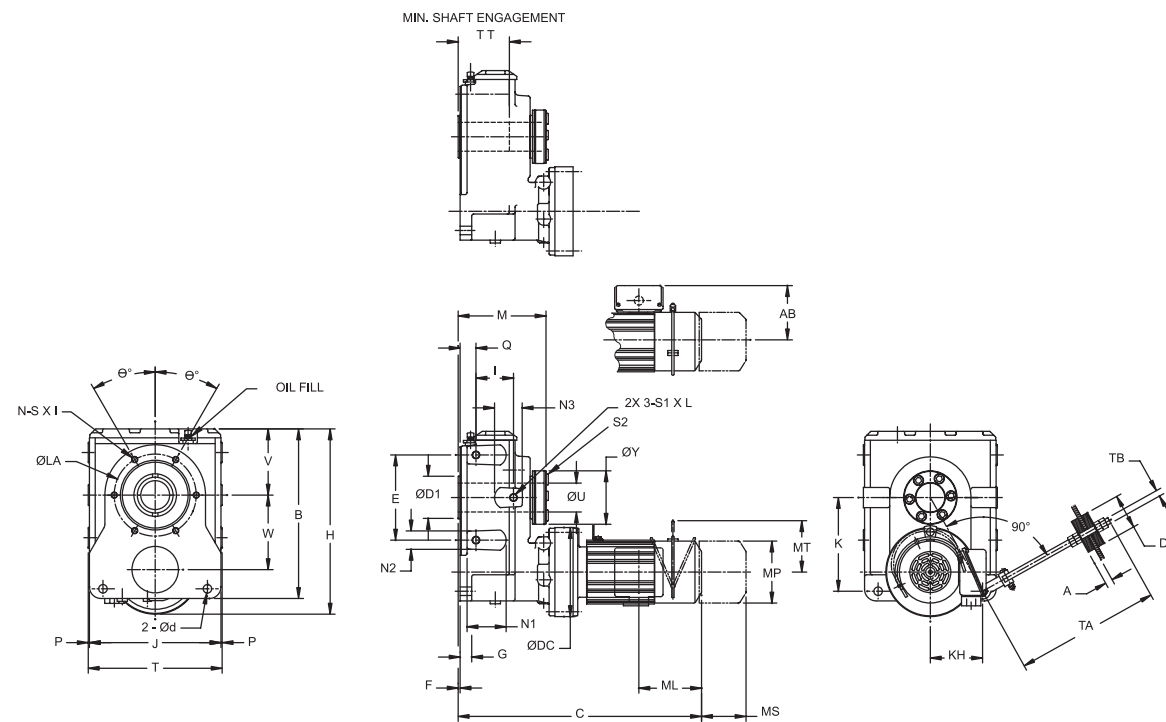

Cyclo® HBB

All dimensions are in inches (mm)

Model	B	E	F	G	H	I	J	K	M	P	Q	T	TT	ØU	
														Max (Std)	Min
<b>B612DA</b>	14.45 (367)	7.48 (190)	0.20 (5)	0.98 (25)	16.10 (409)	3.39 (86)	11.42 (290)	7.97 (202)	7.64 (194)	0.12 (3)	1.22 (31)	11.65 (296)	5.63 (143)	2-7/16 (61.9)	1-15/16 (49.2)
<b>B612DB</b>															
<b>C614DA</b>	17.24 (438)	8.66 (220)		1.18 (30)	18.84 (479)	3.82 (97)	13.39 (340)	9.53 (242)	9.17 (233)	0.12 (3)	1.61 (41)	13.62 (346)	7.32 (186)	2-15/16 (74.6)	2-3/16 (55.6)
<b>C614DB</b>															
<b>C614DC</b>															

Model	V	W	ØY	Ød	ØD1	ØDC	KH	N1	N2	N3	S2	TA	A	D	TB
<b>B612DA</b>	5.69 (144.5)	6.40 (163)	4.49 (114)	0.71 (18)	3.94 (100)	8.03 (204)	4.33 (110)	1.34 (32)	1.26 (32)	-	M12	17.87 (454)	0.63 (16)	2.36 (60)	M20
<b>B612DB</b>															
<b>C614DA</b>	6.73 (171)	7.58 (193)	5.43 (138)	0.87 (22)	4.33 (110)	9.06 (230)	5.31 (135)	3.98 (52)	2.05 (52)	2.83 (72)	M16	18.37 (467)	0.75 (19)	3.54 (90)	M24
<b>C614DB</b>															
<b>C614DC</b>															

Dimensions

## Double Reduction EHYM-B612DAY~C614DBY

All dimensions are in inches (mm)

Frames	HPxP (kW x P)	Model	Without Brake					With Brake						
			C	AB	ML	MP <sup>[1]</sup>	Wt	C	AB	ML	MP <sup>[1]</sup>	MS	MT	Wt. lb (kg)
<b>B612DA</b>	1/8 x 4 (0.1 x 4)	EHYM01-B612DAY	16.56 (421)	4.63 (118)	1.38 (35)	ø4.88 (ø124)	164 (75)	17.93 (456)	4.63 (118)	2.76 (70)	ø4.88 (ø124)	1.93 (49)	-	167 (76)
	1/4 x 4 (0.2 x 4)	EHYM02-B612DAY	18.21 (463)		166 (76)		19.47 (495)	169 (77)		20.26 (515)		169 (77)		172 (78)
	1/3 x 4 (0.25 x 4)	EHYM03-B612DAY	19.00 (483)		166 (76)		19.47 (495)	169 (77)		20.26 (515)		169 (77)		172 (78)
	1/2 x 4 (0.4 x 4)	EHYM05-B612DAY	19.00 (483)		169 (77)		20.26 (515)	169 (77)		20.26 (515)		169 (77)		172 (78)
	1/8 x 4 (0.1 x 4)	EHYM01-B612DAY-AV	18.21 (463)		166 (76)		19.47 (495)	169 (77)		20.26 (515)		169 (77)		172 (78)
	1/4 x 4 (0.2 x 4)	EHYM02-B612DAY-AV	19.00 (483)		169 (77)		20.26 (515)	169 (77)		20.26 (515)		169 (77)		172 (78)
<b>B612DB</b>	1/3 x 4 (0.25 x 4)	EHYM03-B612DBY	18.66 (474)	5.67 (144)	2.32 (59)	ø4.88 (ø124)	171 (78)	19.92 (506)	5.67 (144)	5.51 (140)	ø5.94 (ø151)	3.66 (93)	3.94 (100)	174 (79)
	1/2 x 4 (0.4 x 4)	EHYM05-B612DBY	19.45 (494)				174 (79)	20.71 (526)						177 (81)
	3/4 x 4 (0.55 x 4)	EHYM08-B612DBY	21.06 (535)				179 (81)	22.76 (578)						184 (84)
	1/3 x 4 (0.25 x 4)	EHYM03-B612DBY-AV	19.45 (494)				174 (79)	20.71 (526)						177 (81)
	1/2 x 4 (0.4 x 4)	EHYM05-B612DBY-AV	21.06 (535)				181 (82)	22.76 (578)						187 (85)
	3/4 x 4 (0.55 x 4)	EHYM08-B612DBY-AV	22.36 (568)				189 (86)	24.80 (630)						200 (91)
	1 x 4 (0.75 x 4)	EHYM1-B612DBY-EP	22.80 (579)				194 (88)	25.30 (643)						204 (93)

Cyclo® HBB

Frames	HPxP (kW x P)	Model	Without Brake					With Brake						
			C	AB	ML	MP <sup>[1]</sup>	Wt	C	AB	ML	MP <sup>[1]</sup>	MS	MT	Wt. lb (kg)
<b>C614DA</b>	1/4 x 4 (0.2 x 4)	EHYM02-C614DAY	20.75 (527)	4.63 (118)	2.32 (59)	ø4.88 (ø124)	256 (116)	22.01 (559)	4.63 (118)	3.58 (91)	ø4.88 (ø124)	2.40 (61)	-	259 (118)
	1/3 x 4 (0.25 x 4)	EHYM03-C614DAY					21.54 (547)	259 (118)						22.80 (579)
	1/2 x 4 (0.4 x 4)	EHYM05-C614DAY	21.10 (536)			ø5.94 (ø151)		263 (120)						22.36 (568)
	1/4 x 4 (0.2 x 4)	EHYM02-C614DAY-AV					21.89 (556)	ø4.88 (ø124)						266 (120)
<b>C614DB</b>	1/3 x 4 (0.25 x 4)	EHYM03-C614DBY	23.50 (597)	5.67 (144)	3.82 (97)	ø6.30 (ø160)			266 (121)	23.15 (588)	5.67 (144)	5.51 (140)	ø5.94 (ø151)	3.66 (93)
	3/4 x 4 (0.55 x 4)	EHYM08-C614DBY					271 (123)	25.20 (640)	279 (127)					
	1/3 x 4 (0.25 x 4)	EHYM03-C614DBY-AV					266 (121)	23.15 (588)	269 (122)					
	1/2 x 4 (0.4 x 4)	EHYM05-C614DBY-AV					274 (124)	25.20 (640)	279 (127)					
	3/4 x 4 (0.55 x 4)	EHYM08-C614DBY-AV					282 (128)	27.24 (692)	293 (133)					
	1 x 4 (0.75 x 4)	EHYM1-C614DBY-EP					287 (130)	27.74 (705)	297 (135)					
	1.5 x 4 (1.1 x 4)	EHYM1H-C614DBY-EP					294 (134)	29.04 (738)	306 (139)					
	2 x 4 (1.5 x 4)	EHYM2-C614DBY-EP					297 (135)	29.7 (738)	309 (140)					

Dimensions

Notes [1]: DM Dimension Symbol ø = Round Fan Cover  
DM Dimension Symbol = Square Fan Cover

Sumitomo Drive Technologies Cyclo® HBB



# Dimensions

## Double Reduction EHYM-D616DAY~E617DCY

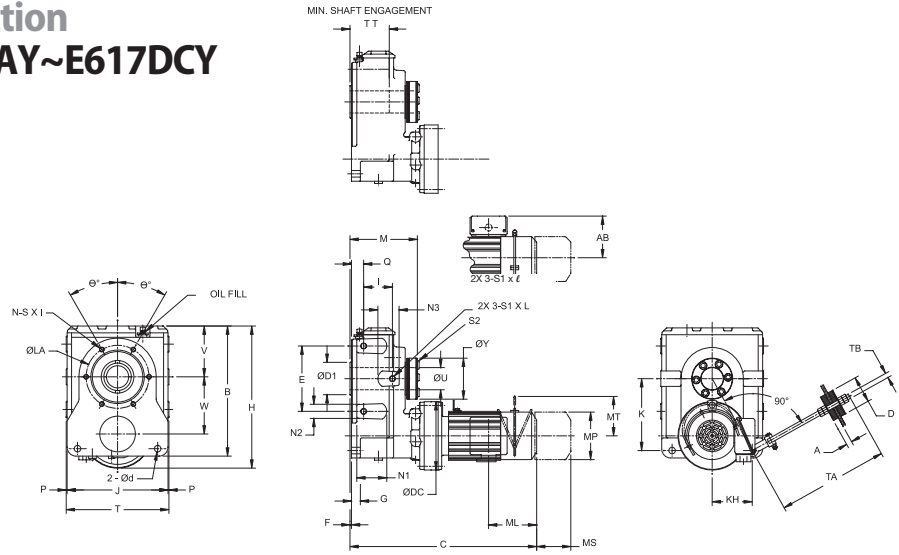

All dimensions are in inches (mm).

Model	B	E	F	G	H	I	J	K	M	P	Q	T	TT	ØU	
														Max (Std)	Min
<b>D616DA</b>	21.22 (539)	9.84 (250)	0.28 (7)	1.38 (35)	23.94 (608)	4.49 (114)	16.77 (426)	11.54 (293)	10.20 (259)	0.20 (5)	1.77 (45)	17.17 (436)	8.03 (204)	3-7/16 (87.3)	2-7/16 (61.9)
<b>D616DB</b>															
<b>D616DC</b>															
<b>E617DA</b>	24.02 (610)	11.81 (300)	1.77 (45)	26.85 (682)	5.00 (127)	18.90 (480)	13.07 (332)	10.98 (279)	1.97 (50)	19.29 (490)	8.82 (224)	3-15/16 (100)	2-15/16 (74.6)		
<b>E617DB</b>															
<b>E617DC</b>															

Model	V	W	ØY	Ød	ØD1	ØDC	KH	N1	N2	N3	S2	TA	A	D	TB
<b>D616DA</b>	8.43 (214)	9.61 (244)	5.98 (152)	1.02 (26)	5.12 (130)	11.81 (300)	6.38 (162)	3.62 (60)	2.36 (60)	3.62 (92)	M16	19.50 (495)	0.75 (19)	3.54 (90)	M24
<b>D616DB</b>															
<b>D616DC</b>															
<b>E617DA</b>	9.45 (240)	10.71 (272)	6.69 (170)	1.30 (33)	5.91 (150)	13.39 (340)	7.09 (180)	3.82 (62)	2.44 (62)	3.94 (100)	20.25 (514)				
<b>E617DB</b>															
<b>E617DC</b>															

# Dimensions

## Double Reduction EHYM-D616DAY~E617DCY

All dimensions are in inches (mm)

Frames	HPxP (kW x P)	Model	Without Brake					With Brake							
			C	AB	ML	MP <sup>[1]</sup>	Wt	C	AB	ML	MP <sup>[1]</sup>	MS	MT	Wt. lb (kg)	
<b>D616DA</b>	1/2 x 4 (0.4 x 4)	EHYM05-D616DAY	24.04 (611)	4.63 (118)	2.32 (59)	ø5.94 (ø151)	470 (213)	25.30 (643)	4.63 (118)	3.58 (91)	ø4.88 (ø124)	2.40 (61)	-	473 (215)	
	3/4 x 4 (0.55 x 4)	EHYM08-D616DAY	25.65 (652)	5.67 (144)	3.82 (97)	ø4.88 (ø124)	474 (215)	27.34 (695)	5.67 (144)	5.51 (140)	ø5.94 (ø151)	3.66 (93)	3.94 (100)	480 (218)	
	1/2 x 4 (0.4 x 4)	EHYM05-D616DAY-AV					477 (217)							483 (219)	
	3/4 x 4 (0.55 x 4)	EHYM08-D616DAY-AV	26.95 (685)	5.86 (149)	3.94 (100)	ø5.94 (ø151)	485 (220)	29.39 (747)	5.86 (149)	6.38 (162)	ø6.30 (ø160)	4.53 (115)	4.29 (109)	496 (225)	
	1 x 4 (0.75 x 4)	EHYM1-D616DAY-EP	27.38 (696)	5.98 (152)	3.82 (97)	ø6.57 (ø167)	490 (223)	29.88 (759)	5.98 (152)	6.32 (161)	ø6.22 (ø158)	5.04 (128)	4.80 (108)	4.25 (108)	500 (227)
	1.5 x 4 (1.1 x 4)	EHYM1H-D616DAY-EP	28.44 (723)	6.16 (156)			498 (226)	31.18 (792)	4.61 (117)	509 (231)					
2 x 4 (1.5 x 4)	EHYM2-D616DAY-EP	501 (227)					4.61 (117)		512 (233)						
<b>D616DB</b>	1.5 x 4 (1.1 x 4)	EHYM1H-D616DBY-EP	29.00 (737)	6.71 (170)	4.53 (115)	ø7.24 (ø184)	502 (228)	31.73 (806)	6.16 (156)	6.56 (167)	ø6.57 (ø167)	5.04 (128)	4.61 (117)	514 (233)	
	2 x 4 (1.5 x 4)	EHYM2-D616DBY-EP	505 (229)				4.61 (117)						517 (235)		
	3 x 4 (2.2 x 4)	EHYM3-D616DBY-EP	29.82 (758)				521 (237)						32.89 (836)	6.71 (170)	7.60 (193)

Frames	HPxP (kW x P)	Model	Without Brake					With Brake							
			C	AB	ML	MP <sup>[1]</sup>	Wt	C	AB	ML	MP <sup>[1]</sup>	MS	MT	Wt. lb (kg)	
<b>E617DA</b>	1/2 x 4 (0.4 x 4)	EHYM05-E617DAY	25.41 (646)	4.63 (118)	2.32 (59)	ø4.88 (ø124)	626 (284)	26.67 (678)	4.63 (118)	3.58 (91)	ø4.88 (ø124)	2.40 (61)	-	629 (286)	
	3/4 x 4 (0.55 x 4)	EHYM08-E617DAY	27.03 (687)	5.67 (144)	3.82 (97)	ø5.94 (ø151)	631 (286)	28.72 (730)	5.67 (144)	5.51 (140)	ø5.94 (ø151)	3.66 (93)	3.94 (100)	637 (289)	
	1/2 x 4 (0.4 x 4)	EHYM05-E617DAY-AV					633 (288)							639 (290)	
	3/4 x 4 (0.55 x 4)	EHYM08-E617DAY-AV	28.33 (720)	5.86 (149)	3.94 (100)	ø6.30 (ø160)	642 (291)	30.77 (782)	5.86 (149)	6.38 (162)	ø6.30 (ø160)	4.53 (115)	4.29 (109)	652 (296)	
	1 x 4 (0.75 x 4)	EHYM1-E617DAY-EP	28.76 (731)	5.98 (152)	3.82 (97)	ø6.57 (ø167)	647 (294)	31.26 (794)	5.98 (152)	6.32 (161)	ø6.22 (ø158)	5.04 (128)	4.80 (108)	4.25 (108)	656 (298)
	1.5 x 4 (1.1 x 4)	EHYM1H-E617DAY-EP	29.82 (758)	6.16 (156)			654 (297)	32.56 (827)	4.61 (117)	666 (302)					
2 x 4 (1.5 x 4)	EHYM2-E617DAY-EP	657 (298)					4.61 (117)		668 (303)						
<b>E617DB</b>	1.5 x 4 (1.1 x 4)	EHYM1H-E617DBY-EP	30.37 (772)	6.71 (170)	4.53 (115)	ø7.24 (ø184)	659 (299)	33.11 (841)	6.16 (156)	6.56 (167)	ø6.57 (ø167)	5.04 (128)	4.61 (117)	670 (304)	
	2 x 4 (1.5 x 4)	EHYM2-E617DBY-EP	662 (300)				4.61 (117)						673 (306)		
	3 x 4 (2.2 x 4)	EHYM3-E617DBY-EP	31.20 (793)				678 (308)						34.27 (871)	6.71 (170)	7.60 (193)
<b>E617DC</b>	3 x 4 (2.2 x 4)	EHYM3-E617DCY-EP	29.92 (760)	6.71 (170)	4.53 (115)	ø7.24 (ø184)	684 (311)	32.99 (838)	6.16 (156)	6.56 (167)	ø6.57 (ø167)	5.04 (128)	4.61 (117)	701 (318)	
	5 x 4 (3.7 x 4)	EHYM5-E617DCY-EP	31.38 (797)				734 (333)								

Notes [1]: DM Dimension Symbol ø = Round Fan Cover  
DM Dimension Symbol = Square Fan Cover

This page intentionally left blank.

Cyclo® HBB

Dimensions

# 4

# Options

---

# Options: Shaft Diameters

Table 4.1 Available Keyed Hollow Bores (in.)

Bore Size (mm.)	Frame Size					
	Z	A	B	C	D	E
1 3/16	○					
1 1/4	○	○				
1 5/16	○	○				
1 3/8	○	○	○			
1 7/16	○	○	○			
1 1/2	○	○	○			
1 9/16		○	○			
1 5/8		○	○			
1 11/16		○	○			
1 3/4		○	○			
1 13/16		○	○			
1 7/8		○	○			
1 15/16		○	○			
2		○	○			
2 1/16		○	○			
2 1/8		○	○			
2 3/16		○	○	○		
2 1/4			○	○		
2 5/16			○	○		
2 3/8			○	○	○	
2 7/16			○	○	○	
2 1/2			○	○	○	
2 9/16			○	○	○	
2 5/8			○	○	○	
2 11/16				○	○	
2 3/4				○	○	
2 13/16				○	○	
2 7/8				○	○	
2 15/16				○	○	○
3				○	○	○
3 1/16				○	○	○
3 1/8				○	○	○
3 3/16				○	○	○
3 1/4					○	○
3 5/16					○	○
3 3/8					○	○
3 7/16					○	○
3 1/2					○	○
3 9/16					○	○
3 5/8					○	○
3 11/16					○	○
3 3/4					○	○
3 13/16						○
3 7/8						○
3 15/16						○
4						○

Table 4.2 Available Keyed Hollow Bores (mm)

Bore Size (mm.)	Frame Size					
	Z	A	B	C	D	E
30	○					
35	○					
40	○					
45		○				
50		○				
55		○	○			
60			○	○		
65			○	○		
70				○	○	
75				○	○	
80				○	○	○
85					○	○
90					○	○
95						○
100						○
105						○
110						○

Symbols: ○ Optional  
Consult factory for price and delivery.

## Keyed Hollow Bore

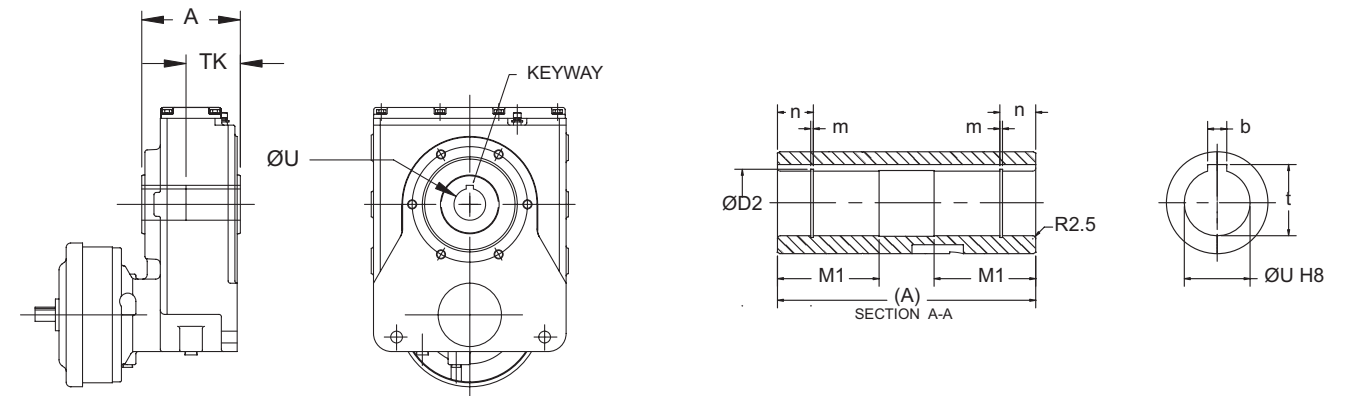

All dimensions are in millimeters.

Model	A	b	t	M1	Ø D2	n	m	TK*
Z	120	12	43.3	57	42.5	24	1.95	76
A	134	16	59.3	63	58	30	2.20	84
B	160	18	69.4	75	68	30	2.70	98
C	192	20	79.9	90	78	37	2.70	140
D	218	22	90.4	100	88.5	37	3.20	194
E	238	28	106.4	110	103.5	37	3.20	195

\*Recommended minimum shaft engagement for shaft material 1045 steel with hardness Hb 225 - 265  
ØU shaft diameters are listed in tables 4.1 and 4.2.

## Output Flange

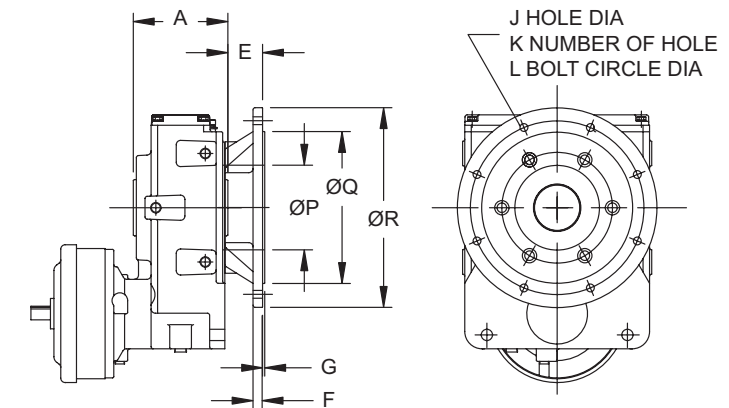

All dimensions are in inches (mm).

Model	A	E	F	G	J	K	L	P	Q	R
Z	4.72 (120)	1.24 (31.5)	0.47 (12)	0.14 (3.5)	0.43 (11)	4	6.50 (165)	3.54 (90)	5.12 (130)	7.87 (200)
A	5.28 (134)	1.30 (33)	0.59 (15)	0.16 (4)	0.55 (14)		8.46 (215)	4.72 (120)	7.09 (180)	10.00 (255)
B	6.30 (160)	1.61 (41)					5.51 (140)	5.51 (140)	9.84 (254)	10.00 (254)
C	7.56 (192)	2.28 (58)	0.79 (20)				11.81 (300)	6.50 (165)	9.84 (250)	13.98 (355)
D	8.58 (218)	3.15 (80)		0.20 (5)	0.71 (18)	8	15.75 (400)	7.68 (195)	13.78 (350)	18.11 (460)
E	9.37 (238)	3.15 (81)	0.87 (22)				12.60 (320)	12.60 (320)	17.72 (455)	17.72 (455)

## Options

## "T" Type Torque Arm

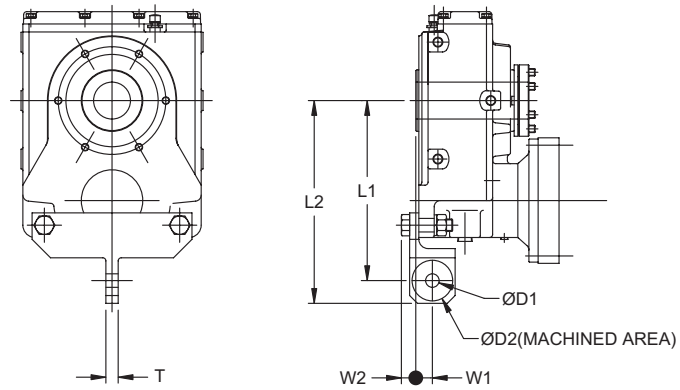

All dimensions are in inches (mm).

Model	L1	L2	W1	W2	T	D1	D2	Bolt Size
Z	8.94 (219)	9.92 (243)	0.71 (17)	0.59 (14)	0.47 (12)	0.55 (14)	1.70 (43)	M12
A	9.39 (230)	10.57 (259)	0.91 (22)	0.67 (16)	0.63 (15)	0.71 (18)	2.09 (53)	M16
B	11.52 (282)	12.97 (318)	1.06 (26)	0.75 (18)	0.79 (19)	0.87 (22)	2.60 (66)	M20
C	14.06 (344)	15.83 (388)	1.26 (31)	1.02 (25)	1.02 (25)	1.02 (26)	3.27 (83)	M24
D	17.05 (418)	18.82 (461)	1.57 (38)	1.18 (29)	1.18 (29)			
E	18.98 (465)	21.14 (518)	2.20 (54)	1.50 (37)	1.42 (35)	1.30 (33)	4.06 (33)	M30

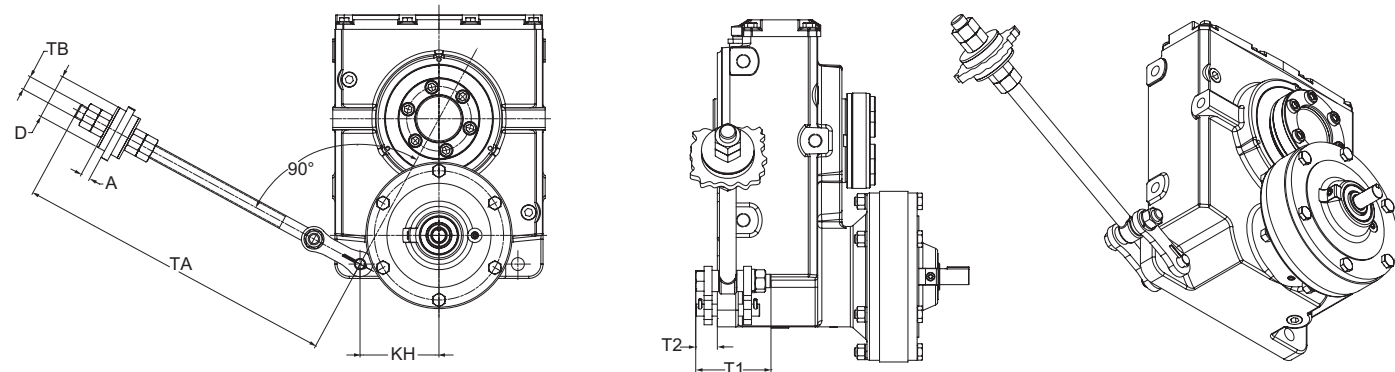
Clevis Type Torque Arm<sup>[1]</sup>

All dimensions are in inches (mm).

Model	A	D	KH	T1	T2	TA	TB
Z	0.63 (16)	2.36 (60)	3.54 (90)	2.40 (61)	0.67 (17)	17.50 (445)	M20
A			3.74 (95)	3.54 (90)	1.02 (26)	17.87 (454)	
B			4.33 (110)	3.54 (90)	1.02 (26)	17.87 (454)	
C	0.75 (19)	3.54 (90)	5.31 (135)	3.90 (99)	1.69 (43)	18.37 (467)	M24
D			6.38 (162)	4.41 (112)	1.87 (47.5)	19.50 (495)	
E			7.09 (180)	5.04 (128)	1.30 (33)	20.25 (514)	

Note: [1] These clevis type torque arm dimensions also appear in all Cyclo HBB reducer and gearmotor dimension drawings in Sections 2 and 3 of this catalog.

## Options

## Screw Conveyor Drive

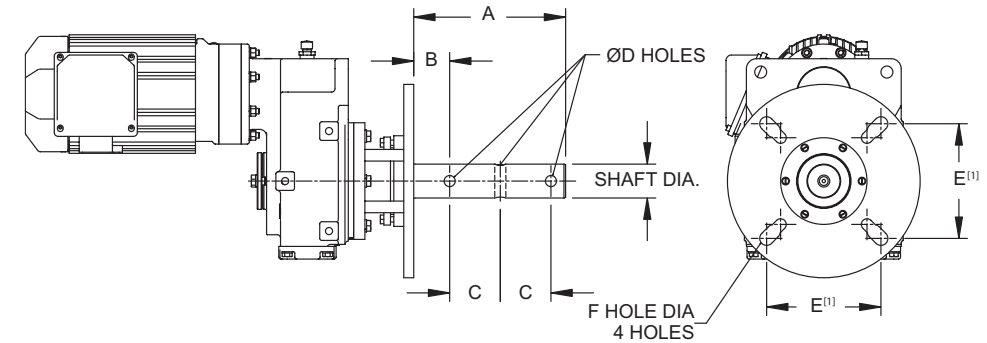

- Complete Cyclo® HBB screw conveyor drive consists of reducer, CEMA drive shaft assembly and mounting adapter kit. The CEMA drive shaft and mounting adapter kit require customer assembly.
- All Cyclo® HBB reducers used as screw conveyor drives require suffix R1, high capacity bearings.
- CEMA drive shafts are three hole style.

All dimensions are in inches.

Model	Shaft Dia.	A	B	C	ØD	E <sup>[1]</sup>	F
Z, A, B	1-1/2	9	2.13	3	17/32	4	0.531
	2	9	2.13	3	21/32	5.13	0.669
	2-7/16	9.69	2.75	3	21/32	5.63	0.669
	3	9.88	2.88	3	25/32	6	0.827
C, D, E	2	9	2.13	3	21/32	5.13	0.669
	2-7/16	9.69	2.75	3	21/32	5.63	0.669
	3	9.88	2.88	3	25/32	6	0.827
	3-7/16	13.13	3.88	4	29/32	6.75	0.827

Note: [1] The dimension shown is E maximum.

HBB Reducer Model	Drive Shaft Diameter (in.)	To Fit Screw Diameter (in.)	CEMA Steel Drive Shaft Assembly P/N	CEMA Stainless Drive Shaft Assembly P/N	Mounting Adapter Kit P/N
Z	1-1/2	6, 9	117Z4108-C3	117Z4108-S3	117Z4050
	2	9, 12	117Z4200-C3	117Z4200-S3	
	2-7/16	12, 14	117Z4207-C3	117Z4207-S3	
	3	12-20	117Z4300-C3	117Z4300-S3	
A	1-1/2	6, 9	116E4108-C3	116E4108-S3	117A40451
	2	9, 12	116E4200-C3	116E4200-S3	
	2-7/16	12, 14	116E4207-C3	116E4207-S3	
	3	12-20	116E4300-C3	116E4300-S3	
B	1-1/2	6, 9	116F4108-C3	116F4108-S3	117B4051
	2	9, 12	116F4200-C3	116F4200-S3	
	2-7/16	12, 14	116F4207-C3	116F4207-S3	
	3	12-20	116F4300-C3	116F4300-S3	
C	2	9, 12	116G4200-C3	116G4200-S3	117C4050
	2-7/16	12, 14	116G4207-C3	116G4207-S3	
	3	12-20	116G4300-C3	116G4300-S3	
	3-7/16	18-24	116G4307-C3	116G4307-S3	
D	2	9, 12	116H4200-C3	116H4200-S3	117D4050
	2-7/16	12, 14	116H4207-C3	116H4207-S3	
	3	12-20	116H4300-C3	116H4300-S3	
	3-7/16	18-24	116H4307-C3	116H4307-S3	
E	2-7/16	12, 14	116J4207-C3	116J4207-S3	117E4050
	3	12-20	116J4300-C3	116J4300-S3	
	3-7/16	18-24	116J4307-C3	116J4307-S3	

Dimensions shown are for reference only and are subject to change without notice, unless certified. Certified prints are available after receipt of an order; consult factory.

# Industry Packages

Two food-grade packages are available for use in machinery where there is incidental food contact. (SHIELD360 and Food-Grade)

	Chemical Duty	SHIELD 360*	Food Grade	Low Temp	High Temp	Weather Proof IP54	Wash-down IP55
<b>Motor Portion</b>							
Gasketed Conduit Box	X	X	X			X	X
V Ring Seal- Fan End	X	X	X			X	X
Special Oil Seal				X	X		
Special Windings				X	X		
Sealer @ Joints	X	X	X			X	X
Special Fan				X	X		
Epoxy Paint	X						X
FDA Epoxy Paint			X				
FDA White Top Coat		X					
FDA Stainless Steel Top Coat							
Brake Cover and Seal	X	X				X	X
<b>Reducer Portion</b>							
Severe Duty Breather	X	X				X	X
Epoxy Paint	X						X
FDA Epoxy Paint			X				
FDA White Top Coat		X					
FDA Stainless Steel Top Coat							
FDA Grease Oil/Grease		X	X				
Low Temp Grease / Oil				X			
High Temp Grease / Oil					X		
Double Output Seals	X	X	X	X	X	X	X
High Temperature Seals					X		
Low Temperature Seals				X			
FKM AM & Chemical	X						
Stainless or Tesa Nameplate	X						

Standard unit temperature range is -10 degrees C to 40 degrees C.

Low Temp Package = -30 degrees C Maximum. For lower temperature requirements consult factory.

High Temp Package = 50 degrees C Maximum. For higher temperature requirements consult factory.

# 5

# Technical Information

---

Cyclo® HBB

Technical  
Information

# Exact Ratios

# Exact Ratios

## Exact Ratios for the Helical Buddybox can be calculated as follows:

For Nominal Ratios 11 and 18:1 - the first reduction gear stage is a true planetary configuration. The overall unit reduction ratio is the product of the planetary ratio with the helical stage reduction ratio. Reduction stage ratios can be determined through the gearing tooth count as follows:

$$\text{Calculated Ratio} = (\text{first stage ratio}) \times (\text{second stage ratio}) = \left( \frac{Z_{SUN} + Z_{RING}}{Z_{SUN}} \right) \left( \frac{Z_{GEAR}}{Z_{PINION}} \right)$$

where:  $Z_{SUN} \cdot Z_{RING}$  = Number of teeth in the sun gear and ring gear respectively

For Nominal Ratios greater than 18:1 - the primary reduction stage is the Cyclo. Cyclo ratios are exact thus tooth count information is not required for ratio calculation purposes. The overall reduction ratio is the product of the Cyclo ratio with the helical stage reduction ratio.

**Table 5.1 Helical Buddybox Tooth Counts and Ratios**

Nominal Ratio	Frame Size	Gearing Tooth Count				Calculated Ratio <i>i</i> <sub>OVERALL</sub>
		Planetary		Helical		
		Z <sub>SUN</sub>	Z <sub>RING</sub>	Z <sub>PINION</sub>	Z <sub>GEAR</sub>	
11	Z6090/5					
	A6100/5	46	92	14	49	10.5000
	B6120/5	60	120	14	49	10.5000
	C6140/5	60	120	14	49	10.5000
	D6160/5	60	126	15	52	10.7467
	E6170/5	58	122	15	52	10.7586
18	Z6090/5					
	A6100/5	30	114	14	49	16.8000
	B6120/5	38	148	14	49	17.1316
	C6140/5	38	148	14	49	17.1316
	D6160/5	39	159	15	52	17.6000
	E6170/5	38	154	15	52	17.5158

Nominal Ratio	Frame Size	Gearing Tooth Count			Calculated Ratio <i>i</i> <sub>OVERALL</sub>
		Cyclo	Helical		
		<i>i</i> <sub>CYCLO</sub>	Z <sub>PINION</sub>	Z <sub>GEAR</sub>	
21	Z6090/5	6	15	52	20.8000
	A6100/5	6	14	49	21.0000
	B6120/5	6	14	49	21.0000
	C6140/5	6	14	49	21.0000
	D6160/5	6	15	52	20.8000
	E6170/5	6	15	52	20.8000
28	Z6090/5	8	15	52	27.7333
	A6100/5	8	14	49	28.0000
	B6120/5	8	14	49	28.0000
	C6140/5	8	14	49	28.0000
	D6160/5	8	15	52	27.7333
	E6170/5	8	15	52	27.7333

**Table 5.1 Helical Buddybox Tooth Counts and Ratios (continued)**

Nominal Ratio	Frame Size	Gearing Tooth Count			Calculated Ratio <i>i</i> <sub>OVERALL</sub>
		Cyclo	Helical		
		<i>i</i> <sub>CYCLO</sub>	Z <sub>PINION</sub>	Z <sub>GEAR</sub>	
39	Z6090/5	11	15	52	38.1333
	A6100/5	11	14	49	38.5000
	B6120/5	11	14	49	38.5000
	C6140/5	11	14	49	38.5000
	D6160/5	11	15	52	38.1333
E6170/5	11	15	52	38.1333	
46	Z6090/5	13	15	52	45.0667
	A6100/5	13	14	49	45.5000
	B6120/5	13	14	49	45.5000
	C6140/5	13	14	49	45.5000
	D6160/5	13	15	52	45.0667
E6170/5	13	15	52	45.0667	
53	Z6090/5	15	15	52	52.0000
	A6100/5	15	14	49	52.5000
	B6120/5	15	14	49	52.5000
	C6140/5	15	14	49	52.5000
	D6160/5	15	15	52	52.0000
E6170/5	15	15	52	52.0000	
60	Z6090/5	17	15	52	58.9333
	A6100/5	17	14	49	59.5000
	B6120/5	17	14	49	59.5000
	C6140/5	17	14	49	59.5000
	D6160/5	17	15	52	58.9333
E6170/5	17	15	52	58.9333	
74	Z6090/5	21	15	52	72.8000
	A6100/5	21	14	49	73.5000
	B6120/5	21	14	49	73.5000
	C6140/5	21	14	49	73.5000
	D6160/5	21	15	52	72.8000
E6170/5	21	15	52	72.8000	
88	Z6090/5	25	15	52	86.6667
	A6100/5	25	14	49	87.5000
	B6120/5	25	14	49	87.5000
	C6140/5	25	14	49	87.5000
	D6160/5	25	15	52	86.6667
E6170/5	25	15	52	86.6667	
102	Z6090/5	29	15	52	100.5333
	A6100/5	29	14	49	101.5000
	B6120/5	29	14	49	101.5000
	C6140/5	29	14	49	101.5000
	D6160/5	29	15	52	100.5333
E6170/5	29	15	52	100.5333	
123	Z6090/5	35	15	52	121.3333
	A6100/5	35	14	49	122.5000
	B6120/5	35	14	49	122.5000
	C6140/5	35	14	49	122.5000
	D6160/5	35	15	52	121.3333
E6170/5	35	15	52	121.3333	

Technical Information

Technical Information



# Exact Ratios

**Table 5.1 Helical Buddybox Tooth Counts and Ratios (continued)**

Nominal Ratio	Frame Size	Gearing Tooth Count			Calculated Ratio $i_{OVERALL}$
		Cyclo	Helical		
		$i_{CYCLO}$	$Z_{PINION}$	$Z_{GEAR}$	
151	Z6090/5	43	15	52	149.0667
	A6100/5	43	14	49	150.5000
	B6120/5	43	14	49	150.5000
	C6140/5	43	14	49	150.5000
	D6160/5	43	15	52	149.0667
	E6170/5	43	15	52	149.0667
179	Z6090/5	51	15	52	176.8000
	A6100/5	51	14	49	178.5000
	B6120/5	51	14	49	178.5000
	C6140/5	51	14	49	178.5000
	D6160/5	51	15	52	176.8000
	E6170/5	51	15	52	176.8000
207	Z6090/5	59	15	52	204.5333
	A6100/5	59	14	49	206.5000
	B6120/5	59	14	49	206.5000
	C6140/5	59	14	49	206.5000
	D6160/5	59	15	52	204.5333
	E6170/5	59	15	52	204.5333
249	Z6090/5	71	15	52	246.1333
	A6100/5	71	14	49	248.5000
	B6120/5	71	14	49	248.5000
	C6140/5	71	14	49	248.5000
	D6160/5	71	15	52	246.1333
	E6170/5	71	15	52	246.1333
305	Z6090/5	87	15	52	301.6000
	A6100/5	87	14	49	304.5000
	B6120/5	87	14	49	304.5000
	C6140/5	87	14	49	304.5000
	D6160/5	87	15	52	301.6000
	E6170/5	87	15	52	301.6000
417	Z6090/5	119	15	52	412.5333
	A6100/5	119	14	49	416.5000
	B6120/5				
	C6140/5				
	D6160/5				
	E6170/5				

# Exact Ratios

**Table 5.2 Gearing Tooth Count**

Nominal Ratio	Frame Size	Gearing Tooth Count				Exact Ratio
		Helical		Planetary		
		$Z_{GEAR}$	$Z_{PINION}$	$Z_{SUN}$	$Z_{RING}$	
11	Z6090/5					
	A6100/5	14	49	46	92	10.5000
	B6120/5	14	49	60	120	10.5000
	C6140/5	14	49	60	120	10.5000
	D6160/5	15	52	60	126	10.7467
	E6170/5	15	52	58	122	10.7586
	18	Z6090/5				
A6100/5		14	49	30	114	16.8000
B6120/5		14	49	38	148	17.1316
C6140/5		14	49	38	148	17.1316
D6160/5		15	52	39	159	17.6000
E6170/5		15	52	38	154	17.5158

## Single Reduction

**Table 5.3 Single Reduction Exact Ratios**

	21	28	39	46	53	60	74	88	102	123	151	179	207	249	305	417
<b>Z</b>	20.80	27.73	38.13	45.07	52.00	58.93	72.80	86.67	100.53	121.33	149.07	176.80	204.53	246.13	301.60	412.53
<b>A</b>	21.00	28.00	38.50	45.50	52.50	59.50	73.50	87.50	101.50	122.50	150.50	178.50	206.50	248.50	304.50	416.50
<b>B</b>	21.00	28.00	38.50	45.50	52.50	59.50	73.50	87.50	101.50	122.50	150.50	178.50	206.50	248.50	304.50	-
<b>C</b>	21.00	28.00	38.50	45.50	52.50	59.50	73.50	87.50	101.50	122.50	150.50	178.50	206.50	248.50	304.50	-
<b>D</b>	20.80	27.73	38.13	45.07	52.00	58.93	72.80	86.67	100.53	121.33	149.07	176.80	204.53	246.13	301.60	-
<b>E</b>	20.80	27.73	38.13	45.07	52.00	58.93	72.80	86.67	100.53	121.33	149.07	176.80	204.53	246.13	301.60	-

# Exact Ratios continued

## Double Reduction

Table 5.4 Double Reduction Exact Ratios

	364	424	501	578	683	809	956	1117	1320	1656	1957	2272	2559
<b>Z</b>	360.53	419.47	495.73	572.00	676.00	800.80	946.40	1105.87	1306.93	1639.73	1937.87	2249.87	2534.13
<b>A</b>	364.00	423.50	500.50	577.50	682.50	808.50	955.50	1116.50	1319.50	1655.50	1956.50	2271.50	2558.50
<b>B</b>	364.00	423.50	500.50	577.50	682.50	808.50	955.50	1116.50	1319.50	1655.50	1956.50	2271.50	2558.50
<b>C</b>	364.00	423.50	500.50	577.50	682.50	808.50	955.50	1116.50	1319.50	1655.50	1956.50	2271.50	2558.50
<b>D</b>	360.53	419.47	495.73	572.00	676.00	800.80	946.40	1105.87	1306.93	1639.73	1937.87	2249.87	2534.13
<b>E</b>	360.53	419.47	495.73	572.00	676.00	800.80	946.40	1105.87	1306.93	1639.73	1937.87	2249.87	2534.13

	2944	3511	4365	5177	6472	7228	8880	10658	12184	15530	17966	21620	26492
<b>Z</b>	2915.47	3477.07	4322.93	5127.20	6409.87	7158.67	8794.93	10556.00	12067.47	15381.60	17794.40	-	-
<b>A</b>	2943.50	3510.50	4364.50	5176.50	6471.50	7227.50	8879.50	10657.50	12183.50	15529.50	17965.50	-	-
<b>B</b>	2943.50	3510.50	4364.50	5176.50	6471.50	7227.50	8879.50	10657.50	12183.50	15529.50	17965.50	21619.50	26491.50
<b>C</b>	2943.50	3510.50	4364.50	5176.50	6471.50	7227.50	8879.50	10657.50	12183.50	15529.50	17965.50	21619.50	26491.50
<b>D</b>	2915.47	3477.07	4322.93	5127.20	6409.87	7158.67	8794.93	10556.00	12067.47	15381.60	17794.40	21413.60	26239.20
<b>E</b>	2915.47	3477.07	4322.93	5127.20	6409.87	7158.67	8794.93	10556.00	12067.47	15381.60	17794.40	21413.60	26239.20

# Special Load Guidelines Overhung Load

## Reducer/Gearmotor Output Shaft Allowable Overhung Load

When a sprocket, sheave, or gear is mounted on the slowspeed of a reducer, an overhung load is applied on that shaft. It is necessary to check if the shaft of the Cyclo® HBB Speed Reducer will allow the overhung load. Calculate the overhung load using the following formulas:

1) Radial load, Pr

$$Pr = \frac{TI}{R} \leq \frac{Pro}{Lf \cdot Cf \cdot Sf} \quad (\text{lbs, } N)$$

2) Axial Load, Pa

$$Pa \leq \frac{Pao}{Cf \cdot Sf} \quad (\text{lbs, } N)$$

3) When there is combined radial and axial loading on the output shaft

$$\left( \frac{Pr}{Pro} + \frac{Pa}{Pao} \right) \cdot Cf \cdot Sf \leq 1 \quad (\text{lbs, } N)$$

LEGEND

- Pr** = Actual radial load (lbs, N)
- TI** = Actual transmitted torque on slow speed shaft of reducer (lb-in, N·m)
- R** = Pitch circle radius of sprocket, gear, pulley, etc. (inch, meter)
- Pro** = Allowable radial load (lbs, N)
- Pa** = Actual axial load (lbs, N)
- Pao** = Allowable axial load (lbs, N)
- Cf** = Coupling factor
- Sf** = Service factor
- Lf** = Load Location factor = 1.0

The values shown in the tables within are the allowable OHL when it is applied to the center of the solid shaft extension or at the load-side edge of the hollow bore. Please consult the factory when the center point of the load is located elsewhere.

Table 5.5 Load Connection Factor (Cf)

Type of Connection		Cf
General Purpose Chain	Single Row	1.00
	Double Row	1.25
Machined Gear or Pinion		1.25
Synchronous Belt		1.50
V-Belt		1.50
Flat Belt		2.50

Table 5.6 Shock Factor (Fs)

Force Units: lbs, (N)

Shock Factor	Fs
No Shock	1.0
Moderate Shock	1.3
Heavy Shock	1.6

Table 5.7 Input Shaft Overhung Load Location Factor, Lf

Model	L (inches)									
	0.25 (6.35)	0.50 (12.7)	0.75 (19.05)	1.00 (25.4)	1.25 (31.75)	1.50 (38.1)	1.75 (44.45)	2.00 (50.8)	2.50 (63.5)	3.00 (76.2)
<b>Z6090, Z6095</b>	0.90	1.09	1.52	2.03						
<b>A6100, A6105</b>	0.93	1.09	1.52	2.03						
<b>B6120, B6125</b>		0.87	1.10	1.43	1.77	2.12				
<b>C6140, C6145</b>		0.84	0.98	1.25	1.53	1.83	2.11			
<b>D6160, D6165</b>		0.94	0.97	1.06	1.22	1.36	1.51	1.66		
<b>E6170, E6175</b>			0.95	0.99	1.09	1.23	1.38	1.51	1.79	2.08

Figure 5.1

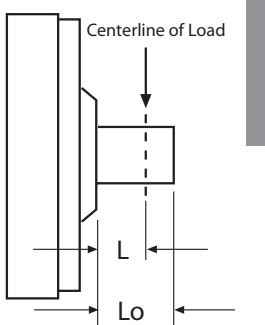

Cyclo® HBB

Technical Information

Cyclo® HBB

Technical Information

# Special Load Guidelines Output Shaft Overhung Load continued

# Special Load Guidelines Inertia continued

**Table 5.8 Input Shaft Allowable Overhung Load (Lf, Cf, Fs =1)**

Unit: lbs.

Model	Ratio	Shaft Speed (RPM)						
		1750	1450	1165	980	870	720	580
<b>Z6090, Z6095</b>	25~71, 119	66	66	66	66	66	66	66
	21, 87	44	44	44	44	55	55	66
<b>A6100, A6105</b>	6~11, 17~119	99	99	110	121	132	132	132
	13, 15	99	77	99	110	110	121	132
<b>B6120, B6125</b>	6~17	133	155	166	175	198	198	198
	21~87	121	99	110	121	133	198	198
<b>C6140, C6145</b>	6, 8	308	308	308	342	364	387	418
	11~21	277	220	243	265	277	297	330
	25	243	254	265	288	297	308	330
	29~87	121	133	133	155	155	155	243
<b>D6160, D6165</b>	8~25, 51, 59	398	398	441	463	486	486	486
	29~43, 71, 87	243	265	288	308	308	353	398
<b>E6170, E6175</b>	11~87	463	463	508	508	528	551	596

**Table 5.9 Moment of Inertia on Motor Shaft of N-Frame Integral Motor**

Units: lb-inch<sup>2</sup> ( $\times 10^{-4}$  kg-m<sup>2</sup>)

Model	Reduction Ratio								
	11	18	21	28	39	46	53	60	74
Z6090, Z6095	–	–	0.475	0.337	0.247	0.245	0.231	0.200	0.150
A6100, A6105	1.737	0.711	0.513	0.331	0.191	0.173	0.149	0.108	0.108
B6120, B6125	5.609	2.213	17.408	1.245	0.735	0.728	0.660	0.496	0.530
C6140, C6145	14.638	5.711	5.130	3.263	2.124	1.662	1.443	1.245	1.019
D6160, D6165	41.724	16.382	13.441	8.721	5.369	4.617	4.036	3.379	2.965
E6170, E6175	87.210	35.226	32.866	22.640	16.142	14.159	12.244	11.457	10.328

Model	Reduction Ratio							
	88	102	123	151	179	207	249	305
Z6090, Z6095	0.142	0.118	0.091	0.088	0.085	0.063	0.083	0.062
A6100, A6105	0.095	0.066	0.059	0.054	0.071	0.048	0.067	0.045
B6120, B6125	0.482	0.340	0.316	0.295	0.400	0.276	0.386	0.263
C6140, C6145	0.913	0.821	0.770	0.708	0.681	0.674	0.650	0.643
D6160, D6165	2.698	2.370	2.226	2.090	2.035	2.028	1.925	1.888
E6170, E6175	9.747	9.166	8.858	8.550	8.413	8.276	8.208	8.140

# Special Load Guidelines Inertia continued

# Lubrication

**Table 5.10 Moment of Inertia on Motor Shaft of N-Frame Integral Motor**

Units: lb-inch<sup>2</sup> (x 10<sup>-4</sup> kg-m<sup>2</sup>)

1 HP (0.75 kW) x 4 Pole		1.5 HP (1.1 kW) x 4 Pole		2 HP (1.5 kW) x 4 Pole		3 HP (2.2 kW) x 4 Pole		5 HP (3.7 kW) x 4 Pole	
Standard	w/ Brake	Standard	w/Brake	Standard	w/Brake	Standard	w/Brake	Standard	w/Brake
8.03 (23.5)	8.82 (25.8)	11.5 (33.7)	13.5 (39.6)	13.4 (39.1)	15.4 (45)	30.1 (88)	33.4 (97.8)	66.3 (194)	71.4 (209)
7.5 HP (5.5 kW) x 4 Pole		10 HP (7.5 kW) x 4 Pole		15 HP (11 kW) x 4 Pole		20 HP (15 kW) x 4 Pole		25 HP (18.5 kW) x 4 Pole	
Standard	w/ Brake	Standard	w/ Brake	Standard	w/ Brake	Standard	w/ Brake	Standard	w/ Brake
99.4 (291)	105 (306)	140 (409)	154 (450)	192 (561)	206 (602)	340 (995)	393 (1150)	875 (2560)	926 (2710)
30 HP (22 kW) x 4 Pole		40 HP (30 kW) x 4 Pole							
Standard	w/ Brake	Standard	w/ Brake						
875 (2560)	926 (2710)	1110 (3260)	1170 (3420)						

**Table 5.11 Moment of Inertia on Motor Shaft of V-Frame Standard Integral Motor**

Units: lb-inch<sup>2</sup> (x 10<sup>-4</sup> kg-m<sup>2</sup>)

1/8 HP (0.1 kW) x 4 Pole		1/4 HP (0.2 kW) x 4 Pole		1/3 HP (0.25 kW) x 4 Pole		1/2 HP (0.4 kW) x 4 Pole		3/4 HP (0.55 kW) x 4 Pole	
Standard	w/ Brake	Standard	w/ Brake	Standard	w/ Brake	Standard	w/ Brake	Standard	w/ Brake
1.11 (3.25)	1.2 (3.5)	1.71 (5)	1.88 (5.5)	1.71 (5)	1.88 (5.5)	2.22 (6.5)	2.31 (6.75)	3.45 (10.1)	3.79 (11.1)

**Table 5.12 Moment of Inertia on Motor Shaft of V-Frame AF Integral Motor**

Units: lb-inch<sup>2</sup> (x 10<sup>-4</sup> kg-m<sup>2</sup>)

1/8 HP (0.1 kW) x 4 Pole		1/4 HP (0.2 kW) x 4 Pole		1/3 HP (0.25 kW) x 4 Pole		1/2 HP (0.4 kW) x 4 Pole		3/4 HP (0.55 kW) x 4 Pole	
Standard	w/ Brake	Standard	w/ Brake	Standard	w/ Brake	Standard	w/ Brake	Standard	w/ Brake
1.71 (5)	1.88 (5.5)	2.22 (6.5)	2.31 (6.75)	2.22 (6.5)	2.31 (6.75)	4.1 (12)	4.44 (13)	6.32 (18.5)	7.11 (20.8)

### Oil lubricated models are not filled with oil prior to shipping.

Before operating, fill the unit with the appropriate amount of the correct lubricant for the mounting position (see Table 5.13). When operating in winter or other relatively low ambient temperatures, use the lower viscosity oil specified for each ambient temperature range. Please consult the factory if the unit will be operated consistently in ambient temperatures other than 32°F–104°F.

**Table 5.13 Lubrication Type**

Unit Size	Output (Helical Gear Portion)	Input (Cyclo® Portion)		
		Motor Horizontal	Motor Vertical Up	Motor Vertical Down
All	Oil	Oil	Oil	Grease

**Table 5.14 Approved Oils**

<b>ExxonMobil</b>	Spartan EP	<b>Idemitsu</b>	Daphne Super Gear Oil	<b>BP</b>	Energol GR-XP
<b>Mobil</b>	Mobilgear 600XP	<b>Kluber</b>	Kluberoll GEM1	<b>Castrol</b>	Alpha SP
<b>Shell</b>	Omala S2 G	<b>Caltex</b>	Meropa	<b>Gulf</b>	EP Lubricant HD

### Grease lubricated models are lubricated with grease prior to shipment from the factory.

Adding grease prior to initial start-up is not required. If grease must be replenished or changed (see Grease Lubrication section), avoid using greases other than those shown in Table 5.14. Please consult the factory when the units will be used in widely fluctuating temperatures, ambient temperatures other than those specified in Table 5.15, or when other special conditions exist for the application. When motors from another manufacturer will be used, please consult and adhere to the associated motor maintenance manual for the appropriate lubrication instructions.

Ambient Temperature							
°F	14	32	50	68	86	104	122
°C	-10	0	10	20	30	40	50
ISO VG	68		100/150			220/320/460	

**Table 5.15 Approved Greases**

Ambient Temperature		Cyclo (Input) Portion	
°F	°C	Ratios 11, 18:1	Ratios 21:1 and higher
14 to 122	-10 to 50	Shell Gadus S2 V220 0	Exxon Unirex N2

# Special Load Guidelines Misc.

## Excessive Overloads

Cyclo® HBB Speed Reducers provide 300% momentary intermittent shock load capacity and are warranted for two years from date of shipment. Refer to our standard terms and conditions for our complete warranty.

## Selection for Applications Involving Shock Loading

For applications involving frequent start-stop, review the recommendations in the selection procedure. For braking or reversing, or quick starting of loads having large inertia, consult factory for model selection or recommended modifications.

## Allowable Radial and Thrust Loads

The loads imposed on the reducer shafts vary with the method of connecting the shaft to the driven machine. Frequently, in addition to torsional forces, radial and thrust loads are applied to the slow speed shaft at the same time. For example,

coupling connections normally involve torsional forces only. However, when power is transmitted through spur gears, belts, pulleys or chains, both torsional and radial forces may be applied to the reducer shafts. When driving through helical gears, all three conditions (torsional, radial and thrust load) may be referred to the reducer shaft.

The reducer shafts and bearings must have sufficient strength to withstand these loads, and it is, therefore, necessary to determine the allowable limits for each condition. Please consult factory for further information.

## Load Centering

The radial load capacities are calculated with the load concentrated at the midpoint of the slow speed shaft extension. Radial load capacities decrease if the center of the load is moved farther from the reducer and the values obtained from the charts must be adjusted accordingly..

**Figure 5.2 Oil Plug Locations**

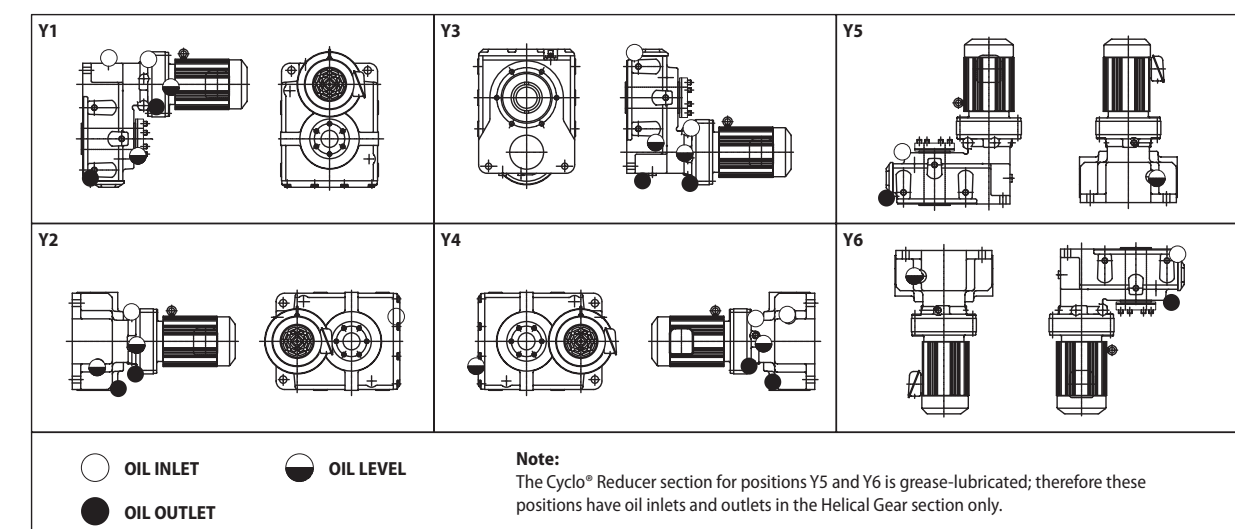

# Lubrication continued

# North American Motor Specifications

## Oil Quantities

Table 5.16 Oil Fill Quantities

\*G = Grease

Model		Y1		Y2		Y3		Y4		Y5		Y6	
		Ltr.	Gal.	Ltr.	Gal.	Ltr.	Gal.	Ltr.	Gal.	Ltr.	Gal.	Ltr.	Gal.
Z609	Output	0.5	0.13	0.5	0.13	0.5	0.13	0.5	0.13	1.4	0.37	0.8	0.21
	Input	G	G	G	G	G	G	G	G	G	G	G	G
A610	Output	0.7	0.18	0.8	0.21	0.7	0.18	0.7	0.18	1.6	0.42	1.1	0.29
	Input	G	G	G	G	G	G	G	G	G	G	G	G
B612	Output	1.4	0.37	1.6	0.42	1.2	0.32	1.6	0.42	3.3	0.87	2.2	0.58
	Input	G	G	G	G	G	G	G	G	G	G	G	G
C614	Output	1.8	0.48	2.3	0.61	1.6	0.42	2.3	0.61	5.2	1.37	3.4	0.9
	Input	0.3	0.08	0.3	0.08	0.3	0.08	0.3	0.08	G	G	G	G
D616	Output	4.4	1.16	4.7	1.24	3.4	0.90	4.6	1.22	9.6	2.54	7.4	1.95
	Input	0.6	0.16	0.6	0.16	0.6	0.16	0.6	0.16	G	G	G	G
E617	Output	5.6	1.48	6.8	1.80	4.1	1.08	6.7	1.77	13	3.43	10.1	2.67
	Input	0.9	0.24	0.9	0.24	0.9	0.24	0.9	0.24	G	G	G	G

**Oil lubricated units** are shipped without oil. Prior to initial start-up, the unit must be filled with the correct amount of oil (see Table 5.16). For those units where both the gear and Cyclo® portions are oil lubricated, the oil must be filled in two separate locations, one on the gear housing and one on the Cyclo® housing.

The helical (output) portion of all **double reduction units** is oil lubricated and must be filled by the customer with the correct amount of oil (see Table 5.16) prior to initial start-up.

**Grease lubricated models** are lubricated at the factory. Additional grease does not need to be added prior to initial start-up.

The Cyclo® (input) portion of all **double reduction units** are grease lubricated at the factory. Additional grease does not need to be added prior to initial start-up.

## Grease Replenishment and Change Interval

A. On single reduction Cyclo® Helical Buddybox (Cyclo® HBB) sizes Z6090/95, A6100/05 and B6120/25, the Cyclo® portion is grease lubricated as standard and therefore maintenance free. Consult the operations and maintenance manual for the grease change interval.

B. When mounting Cyclo® HBB sizes C6140/45, D6160/65 and E6170/75 in the Y5 and Y6 positions, please consult the maintenance and operations manual for the proper grease replenishment and change interval for the Cyclo® portion.

## Oil Replenishment and Change Interval

A. Maintain proper oil levels at all times.

B. An oil change after the first 500 hours of operation is highly recommended.

C. Sumitomo recommends an oil change every 2500 hours, or six months, whichever comes first. If a proper preventive maintenance program is implemented and maintained, a longer change period may be acceptable.

D. If the unit is running in a high ambient, high humidity, or corrosive environment, the lubricant will have to be changed more frequently. Consult the factory for recommendations.

E. Note: The Cyclo® portion and Helical portion, where applicable, must be filled with oil separately. Oil does not flow from one section to the other.

Feature	All Motors
Motor Type	3-Phase AC Asynchronous Squirrel Cage Induction Motor
Motor Standard	NEMA
Power Range	1/8 through 40 HP (0.1 through 30 kW)
Number of Poles	4 Poles
Motor Power Supply	230 / 460 Volts, 60 Hz, 3 phase 575 Volts, 60 Hz, 3 phase
Synchronous RPM (Slip)	1800 RPM (20 - 100 RPM - See Motor Nameplate)
NEMA Design	A or B (See Motor Nameplate)
Efficiency	1/8 through 3/4 HP (Standard Efficiency - IE1) 1 through 40 HP (Premium Efficiency - IE3)
Motor Temperature Rise	Class B
Motor Insulation	Class F Tropicalized
Service Factor	Sinusoidal Utility Power: 1.15, Inverter Power: 1.0
Time Rating	Continuous
Frame Material	Diecast Aluminum
Enclosure Type	1/8 HP - TENV, 1/4 HP - 40 HP - TEFC
Enclosure Rating	IP55 Outdoor and Indoor Neoprene v-ring, gaskets and slinger shaft seals
Conduit Box	Outdoor Gasketed Oversized Diecast Aluminum, NPT Conduit Thread (Optional Indoor Steel)
Certification	UL Recognition, CSA Certification, CE Marked
Inverter Compatibility	Motor Insulation MG1 Part 31 Compliant
Constant Torque Speed Range	See Below
Overspeed Operation	Up to 120 Hz <b>Check Reducer and Driven Equipment Overspeed Rating!</b>
Motor Bearings	Double shielded, Deep Groove, Sealed for Life, CM Reduced Clearance Ball Bearings
Fan Guard (TEFC)	Steel
Fan (TEFC)	1/8 - 3/4 HP (PBT) 1 - 40 HP (Nylon Resin - PA66 with 30% Glass Fiber)
Lifting Provisions	(1 - 40 HP) Eyebolt

Feature	Non-Brake Motor	Brake Motor
Constant Torque Speed Range	See page 3.8 for table.	See page 3.8 for table.
208V Motor Power	Usable on 208V Network	Motor usable on 208V network but supply 230V for brake control
Brake Power Supply	-----	230 / 460 Volts, 60 Hz, 1 phase 575 Volts, 60 Hz, 1 phase
Brake Insulation	-----	Class F
Manual Brake Release Mechanism	-----	1/8 - 1/2 HP - no release mechanism 3/4 - 40 HP - one-touch lever type release

Cyclo® HBB

Cyclo® HBB

Technical Information

Technical Information

# Motor Optional Conduit Box Location

# Motor

**NOTE:** Default Terminal Box position for Gearmotors is N33/ N3B for all mounting positions (Y1 thru Y6).  
 ← : The arrow indicates direction of lead wire out of conduit box.

## Standard Mounting Direction of Terminal Box

The terminal box mounting position can be rotated in increments of 90 degrees (N33, N34, N35, N36).  
 The terminal box cable entry port can also be rotated in increments of 90 degrees (N3A, N3B, N3C, N3D).  
 Specify the terminal box mounting configuration based on figures shown below.  
 The conduit box orientation is shown relative to HBB casing. For orientation of the HBB, please see page 1.7.

**Figure 5.3 Terminal Box Mounting Options for Y1 Position**

Cable Port Direction	Terminal Box Mounting Position (As viewed from Motor Fan Side)			
	Left Side (N33) (Viewed from Output Shaft Side)	Right Side (N34) (Viewed from Output Shaft Side)	Top Side (N35)	Bottom Side (N36)
Type A (N3A)				
Type B (N3B)				
Type C (N3C)				
Type D (N3D)				

**Figure 5.4 Terminal Box Mounting Options for Y2, Y3, Y4, Y5, Y6 Positions**

Cable Port Direction	Terminal box mounting position (As viewed from Motor Fan Side)			
	Left Side (N33) (Viewed from Output Shaft Side)	Right Side (N34) (Viewed from Output Shaft Side)	Top Side (N35)	Bottom Side (N36)
Type A (N3A)				
Type B (N3B)				
Type C (N3C)				
Type D (N3D)				

Special consideration must be given to terminal box location N35 in mounting position Y2 if the unit is oil lubricated. The conduit box may interfere with the unit's oil plumbing system. Another conduit box location should be selected if possible. If location N35 must be used, consult the factory.

## Motor Installation: Fan/Brake Cover Clearance Requirements

**Required gearmotor clearance dimension FA and FB for installation to achieve best performance and proper maintenance.**

**Dimension FA:** Clearance dimension necessary to remove fan cover or brake cover without removing the motor from the equipment.

**Dimension FB:** Minimum clearance to provide adequate ventilation.

**Notes:** 1. In some cases, it may be necessary to move the gearmotor to remove the fan cover or brake cover.

2. Dimension FB is the minimum clearance when the fan cover is up against a closed wall.

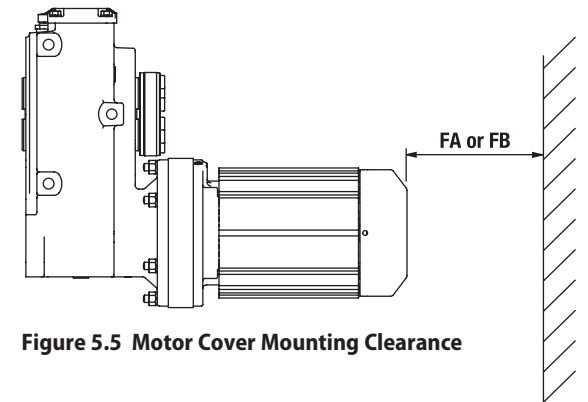

**Figure 5.5 Motor Cover Mounting Clearance**

**Table 5.17a Motor Clearance Requirements for Standard IE1 motors (1/8 to 3/4 hp)**

Frame Size	IE1 Motor		Standard 3-Phase Motor		3-Phase With Brake Motor	
	HP x Pole	kW x Pole	FA	FB	FA	FB
V-63S	1/8 x 4	0.1 x 4	-	-	2.0 (49)	-
V-63M	1/4 x 4	0.2 x 4	1.9 (48)	0.8 (20)	2.5 (63)	0.8 (20)
V-63M	1/3 x 4	0.25 x 4				
V-71M	1/2 x 4	0.4 x 4	1.9 (48)	0.8 (20)	2.5 (63)	0.8 (20)
V-80S	3/4 x 4	0.55 x 4	2.0 (49)	0.8 (20)	3.7 (93)	0.8 (20)

inch (mm)

**Table 5.17b Motor Clearance Requirements for AF - motors (1/8 to 3/4 hp)**

Frame Size	IE1 Motor		Standard 3-Phase Motor		3-Phase With Brake Motor	
	HP x Pole	kW x Pole	FA	FB	FA	FB
VA-63S	1/8 x 4	0.1 x 4				
VA-63M	1/4 x 4	0.2 x 4	1.9 (48)	0.8 (20)	2.5 (63)	0.8 (20)
VA-63M	1/3 x 4	0.25 x 4				
VA-71M	1/2 x 4	0.4 x 4	2.0 (49)	0.8 (20)	3.7 (93)	0.8 (20)
VA-80S	3/4 x 4	0.55 x 4	2.1 (52)	0.8 (20)	4.6 (115)	0.8 (20)

inch (mm)

**Table 5.17c Motor Clearance Requirements for EP motors (1 to 15 hp)**

Frame Size	IE3 Motor		3-Phase Without Brake Motor		3-Phase Brake (B) Motor	
	HP x Pole	kW x Pole	FA	FB	FA	FB
N-80M	1 x 4	0.75 x 4	2.3 (59)	0.8 (20)	4.8 (122)	0.8 (20)
N-90S	1.5 x 4	1.1 x 4				
N-90L	2 x 4	1.5 x 4	2.3 (59)	0.8 (20)	5.0 (128)	0.8 (20)
N-100L	3 x 4	2.2 x 4	2.4 (60)	0.8 (20)	5.4 (138)	0.8 (20)
N-112M	5 x 4	3.7 x 4				
N-132S	7.5 x 4	5.5 x 4	2.5 (63)	1.0 (25)	6.0 (153)	0.8 (20)
N-132M	10 x 4	7.5 x 4				
N-160M	15 x 4	11 x 4	3.3 (84)	1.2 (30)	7.4 (189)	1 (25)
N-160L	20 x 4	15 x 4	4.2 (107)	1.2 (30)	9.5 (242)	1.2 (30)
N-180MS	25 x 4	18.5 x 4				
N-180M	30 x 4	22 x 4	5.3 (134)	1.2 (30)	12.1 (308)	1.2 (30)
N-180L	40 x 4	30 x 4				
N-200L	50 x 4	37 x 4	5.3 (134)	1.2 (30)	13.6 (345)	1.2 (30)
N-200LL	60 x 4	45 x 4	6.7 (171)	1.2 (30)	14.8 (376)	1.2 (30)

inch (mm)

Technical Information

Technical Information

# Motor continued

# Motor continued

## Motor Conduit Box Details

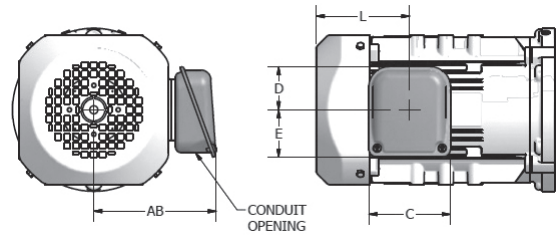

Figure 5.6 Indoor Duty (Optional) Box

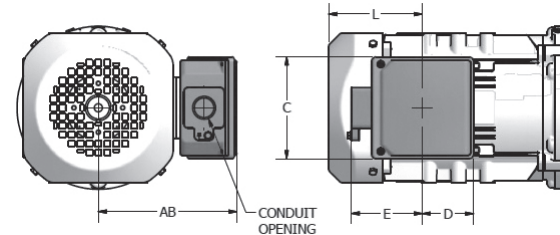

Figure 5.7 Global EP.NA and Outdoor Duty Box

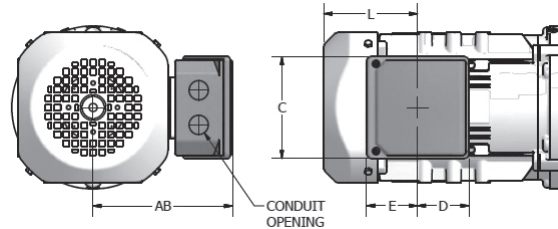

Figure 5.8 Global IE3 CE Box

Table 5.18 Conduit Box Information

Frame Size	Duty Rating	General Dimensions				Without Brake		With Brake		Conduit Opening	Material
		AB	C	D	E	Availability	L	Availability	L		
V-63S	Indoor Duty (Optional)	4.11 (105)	3.35 (85)	2.09 (53)	1.69 (43)	Yes	1.38 (35)	CF <sup>(1)</sup>	2.76 (70)	Ø0.90 (Ø23)	Steel
	Indoor Duty Brake (Optional)	4.32 (110)	3.94 (100)	2.29 (58)	2.10 (53)			Yes		Ø0.90 (Ø23)	Steel
	Outdoor Duty (Optional)	4.98 (127)	3.94 (100)	2.42 (62)	2.76 (70)			Yes		NPT1/2 <sup>(2)</sup>	Steel
	Global	4.63 (118)	4.09 (104)	2.24 (57)	2.16 (55)			Yes		NPT1/2	Al Diecast
	Global CE	4.63 (118)	4.09 (104)	2.24 (57)	2.16 (55)			Yes		M16, M25	Al Diecast
VA-63S V-63M VA-63M V-71M	Indoor Duty (Optional)	4.11 (105)	3.35 (85)	2.09 (53)	1.69 (43)	Yes	2.32 (59)	CF <sup>(1)</sup>	3.58 (91)	Ø0.90 (Ø23)	Steel
	Indoor Duty Brake (Optional)	4.32 (110)	3.94 (100)	2.29 (58)	2.10 (53)			Yes		Ø0.90 (Ø23)	Steel
	Outdoor Duty (Optional)	4.98 (127)	3.94 (100)	2.42 (62)	2.76 (70)			Yes		NPT1/2 <sup>(2)</sup>	Steel
	Global	4.63 (118)	4.09 (104)	2.24 (57)	2.16 (55)			Yes		NPT1/2	Al Diecast
	Global CE	4.63 (118)	4.09 (104)	2.24 (57)	2.16 (55)			Yes		M16, M25	Al Diecast
VA-71M V-80S	Indoor Duty (Optional)	4.69 (119)	3.35 (85)	1.72 (44)	2.04 (52)	Yes	3.82 (97)	CF <sup>(1)</sup>	5.51 (140)	Ø0.90 (Ø23)	Steel
	Indoor Duty Brake (Optional)	5.68 (144)	4.80 (122)	2.60 (66)	2.84 (72)			Yes		Ø0.90 (Ø23)	Steel
	Outdoor Duty (Optional)	5.55 (141)	3.94 (100)	2.20 (56)	2.95 (75)			Yes		G3/4 <sup>(2)</sup>	Steel
	Global	5.67 (144)	4.92 (125)	2.50 (64)	3.43 (87)			Yes		NPT3/4 <sup>(2)</sup>	Al Diecast
	Global CE	5.71 (145)	4.92 (125)	2.50 (64)	2.47 (63)			Yes		2 - M25	Al Diecast
VA-80S	Indoor Duty (Optional)	4.88 (124)	3.35 (85)	1.72 (44)	2.04 (52)	Yes	3.94 (100)	CF <sup>(1)</sup>	6.38 (162)	Ø0.90 (Ø23)	Steel
	Indoor Duty Brake (Optional)	5.87 (149)	4.80 (122)	2.60 (66)	2.84 (72)			Yes		Ø0.90 (Ø23)	Steel
	Outdoor Duty (Optional)	5.75 (146)	3.94 (100)	2.20 (56)	2.95 (75)			Yes		G3/4 <sup>(2)</sup>	Steel
	Global	5.86 (149)	4.92 (125)	2.50 (64)	3.43 (87)			Yes		NPT3/4 <sup>(2)</sup>	Al Diecast
	Global CE	5.91 (150)	4.92 (125)	2.50 (64)	2.47 (63)			Yes		2 - M25	Al Diecast

(1) For "Available?" identified with "CF", please consult factory for brake configuration supporting this conduit box.

(2) Default thread option shown. Alternate thread options available. Please consult factory for alternate conduit thread options

Table 5.18 Conduit Box Information (cont.)

Frame Size	Duty Rating	General Dimensions				Without Brake		With Brake		Conduit Opening	Material
		AB	C	D	E	Availability	L	Availability	L		
N-80M	Indoor Duty (Optional)	4.85 (123)	3.35 (85)	1.72 (44)	2.04 (52)	Yes	3.82 (97)	CF <sup>(1)</sup>	6.32 (161)	Ø0.90 (Ø23)	Steel
	Indoor Duty Brake (Optional)	5.99 (152)	4.80 (122)	2.60 (66)	2.84 (72)			Yes		Ø0.90 (Ø23)	Steel
	Outdoor Duty (Optional)	5.87 (149)	3.94 (100)	2.20 (56)	2.95 (75)			Yes		G3/4 <sup>(2)</sup>	Steel
	Global EP.NA	5.98 (152)	4.92 (125)	2.50 (64)	3.43 (87)			Yes		NPT3/4 <sup>(2)</sup>	Al Diecast
	Global IE3 CE	6.02 (153)	4.92 (125)	2.50 (64)	2.47 (63)			Yes		2 - M25	Al Diecast
N-90S N-90L	Indoor Duty (Optional)	5.03 (128)	3.35 (85)	1.72 (44)	2.04 (52)	Yes	3.82 (97)	CF <sup>(1)</sup>	6.56 (167)	Ø0.90 (Ø23)	Steel
	Indoor Duty Brake (Optional)	6.17 (157)	4.80 (122)	2.60 (66)	2.84 (72)			Yes		Ø0.90 (Ø23)	Steel
	Outdoor Duty (Optional)	6.04 (154)	3.94 (100)	2.20 (56)	2.95 (75)			Yes		G3/4 <sup>(2)</sup>	Steel
	Global EP.NA	6.16 (156)	4.92 (125)	2.50 (64)	3.43 (87)			Yes		NPT3/4 <sup>(2)</sup>	Al Diecast
	Global IE3 CE	6.20 (158)	4.92 (125)	2.50 (64)	2.47 (63)			Yes		2 - M25	Al Diecast
N-100L N-112S	Indoor Duty (Optional)	5.93 (151)	3.94 (100)	2.09 (53)	2.29 (58)	Yes	4.53 (115)	CF <sup>(1)</sup>	7.60 (193)	Ø0.90 (Ø23)	Steel
	Indoor Duty Brake (Optional)	6.72 (171)	4.80 (122)	2.60 (66)	2.84 (72)			Yes		Ø0.90 (Ø23)	Steel
	Outdoor Duty (Optional)	7.21 (183)	4.84 (123)	2.52 (64)	3.43 (87)			Yes		G3/4 <sup>(2)</sup>	Steel
	Global EP.NA	6.71 (170)	4.92 (125)	2.50 (64)	3.43 (87)			Yes		NPT3/4 <sup>(2)</sup>	Al Diecast
	Global IE3 CE	6.75 (172)	4.92 (125)	2.50 (64)	2.47 (63)			Yes		2 - M25	Al Diecast
N-112M	Indoor Duty (Optional)	6.56 (167)	3.94 (100)	2.09 (53)	2.29 (58)	Yes	4.65 (118)	CF <sup>(1)</sup>	8.21 (209)	Ø0.90 (Ø23)	Steel
	Indoor Duty Brake (Optional)	7.35 (187)	4.80 (122)	2.60 (66)	2.84 (72)			Yes		Ø0.90 (Ø23)	Steel
	Outdoor Duty (Optional)	7.84 (199)	4.84 (123)	2.52 (64)	3.43 (87)			Yes		G3/4 <sup>(2)</sup>	Steel
	Global EP.NA	7.34 (186)	4.92 (125)	2.50 (64)	3.43 (87)			Yes		NPT3/4 <sup>(2)</sup>	Al Diecast
	Global IE3 CE	7.38 (188)	4.92 (125)	2.50 (64)	2.47 (63)			Yes		2 - M25	Al Diecast
N-132S	Indoor Duty (Optional)	6.56 (167)	3.94 (100)	2.09 (53)	2.29 (58)	Yes	4.65 (118)	CF <sup>(1)</sup>	8.21 (209)	Ø0.90 (Ø23)	Steel
	Indoor Duty Brake (Optional)	7.35 (187)	4.80 (122)	2.60 (66)	2.84 (72)			Yes		Ø0.90 (Ø23)	Steel
	Outdoor Duty (Optional)	7.84 (199)	4.84 (123)	2.52 (64)	3.43 (87)			Yes		G1 <sup>(2)</sup>	Steel
	Global EP.NA	7.34 (186)	4.92 (125)	2.50 (64)	3.43 (87)			Yes		NPT1 <sup>(2)</sup>	Al Diecast
	Global IE3 CE	7.38 (188)	4.92 (125)	2.50 (64)	2.47 (63)			Yes		2 - M25	Al Diecast
N-132M	Indoor Duty (Optional)	7.98 (203)	4.80 (122)	2.60 (66)	2.84 (72)	Yes	5.43 (138)	Yes	9.57 (243)	Ø1.69 (Ø43)	Steel
	Outdoor Duty (Optional)	9.26 (235)	6.06 (154)	3.11 (79)	4.13 (105)					G1 <sup>(2)</sup>	Steel
	Global EP.NA	9.04 (230)	6.69 (170)	3.40 (86)	4.43 (113)					NPT1 <sup>(2)</sup>	Al Diecast
N-160M	Global IE3 CE	9.04 (230)	6.69 (170)	3.40 (86)	3.51 (89)	Yes	5.43 (138)	Yes	9.57 (243)	2-M32	Al Diecast
	Indoor Duty (Optional)	7.98 (203)	4.80 (122)	2.60 (66)	2.84 (72)					Ø1.69 (Ø43)	Steel
	Outdoor Duty (Optional)	9.26 (235)	6.06 (154)	3.11 (79)	4.13 (105)					G1-1/4 <sup>(2)</sup>	Steel
	Global EP.NA	9.04 (230)	6.69 (170)	3.40 (86)	4.43 (113)					NPT1-1/4 <sup>(2)</sup>	Al Diecast
N-160M	Global IE3 CE	9.04 (230)	6.69 (170)	3.40 (86)	3.51 (89)	Yes	5.43 (138)	Yes	9.57 (243)	2-M32	Al Diecast
	Indoor Duty (Optional)	7.98 (203)	4.80 (122)	2.60 (66)	2.84 (72)					Ø1.69 (Ø43)	Steel

Technical Information

Technical Information

# Motor continued

# Motor continued

**Table 5.18 Conduit Box Information (cont.)**

inch (mm)

Motor Model	Duty	Dimensions (inches)				Yes	7.01 (178)	No	12.30 (313)	Conduit	
		W	H	D	Depth					Ø	Material
N-160L	Indoor Duty (Optional)	9.20 (234)	4.80 (122)	2.60 (66)	2.84 (72)	Yes	7.01 (178)	No	12.30 (313)	Ø1.69 (Ø43)	Steel
	Indoor Duty Brake (Optional)	10.16 (258)	6.54 (166)	3.48 (88)	3.89 (99)			Yes		Ø1.69 (Ø43)	Steel
	Outdoor Duty (Optional)	10.48 (266)	6.06 (154)	3.11 (79)	4.13 (105)			Yes		G1-1/4 <sup>(2)</sup>	Steel
	Global EP.NA	10.26 (261)	6.69 (170)	3.40 (86)	4.43 (113)			Yes		NPT1-1/4 <sup>(2)</sup>	Al Diecast
	Global IE3 CE	10.26 (261)	6.69 (170)	3.40 (86)	3.51 (89)			Yes		2-M32	Al Diecast
N-180MS N-180M	Indoor Duty (Optional)	11.69 (297)	6.54 (166)	3.48 (88)	3.89 (99)	Yes	9.06 (230)	Yes	15.91 (404)	Ø1.93 (Ø49)	Steel
	Outdoor Duty (Optional)	14.08 (358)	7.56 (192)	4.53 (115)	6.89 (175)					G1-1/4 <sup>(2)</sup>	Cast Iron
	Global EP.NA	13.39 (340)	9.02 (229)	4.38 (111)	5.47 (139)					NPT1-1/4 <sup>(2)</sup>	Cast Iron
	Global IE3 CE	13.39 (340)	9.02 (229)	4.38 (111)	4.43 (113)					2 - M40	Cast Iron
N-180L N-200L	Indoor Duty (Optional)	11.69 (297)	6.54 (166)	3.48 (88)	3.89 (99)	Yes	9.06 (230)	Yes	15.91 (404)	Ø1.93 (Ø49)	Steel
	Outdoor Duty (Optional)	14.08 (358)	7.56 (192)	4.53 (115)	6.89 (175)					G2 <sup>(2)</sup>	Cast Iron
	Global EP.NA	13.39 (340)	9.02 (229)	4.38 (111)	5.47 (139)					NPT2 <sup>(2)</sup>	Cast Iron
	Global IE3 CE	13.39 (340)	9.02 (229)	4.38 (111)	4.43 (113)					2 - M40	Cast Iron
N-200LL N-225S	Indoor Duty (Optional)	16.24 (413)	9.45 (240)	4.19 (106)	6.30 (160)	Yes	16.81 (427)			Ø3.03 (Ø77)	Steel
	Outdoor Duty (Optional)	19.03 (483)	10.16 (258)	5.28 (134)	11.50 (292)					G2-1/2 <sup>(2)</sup>	Cast Iron
	Global EP.NA	16.54 (420)	10.63 (270)	5.14 (131)	6.22 (158)					NPT3 <sup>(2)</sup>	Cast Iron
	Global IE3 CE	16.54 (420)	10.63 (270)	5.14 (131)	5.13 (130)					2 - M63	Cast Iron

(1) For "Available?" identified with "CF", please consult factory for brake configuration supporting this conduit box.  
 (2) Default thread option shown. Alternate thread options available. Please consult factory for alternate conduit thread options

## Fractional Motor Performance Data - 60Hz Operation

**Table 5.19a Three Phase, 230/460V, 60Hz, 1800 RPM Synchronous Speed, TEFC - UL Recognized**

Motor Capacity		Frame Size	Full Load (A)			Current				Starting Torque % of FL	Breakdown Torque % of FL	Nominal Efficiency %	Power Factor %	NEMA Code Letter
HP	kW		Rated RPM	Torque		Full Load		No Load % of FL	Starting % of FL					
				in-lbs	N-m	230V	460V							
1/8**	0.1	V-63S	1730	4.55	0.514	0.66	0.33	86.1	424	326	308	63.3	60.0	K
1/4	0.2	V-63M	1730	9.10	1.03	1.12	0.56	79.6	464	300	287	69.2	65.1	K
1/3	0.25	V-63M	1700	12.2	1.38	1.24	0.62	72.0	419	237	226	70.1	72.0	G
1/2	0.4	V-71M	1750	18.0	2.03	2.15	1.08	77.7	456	295	276	71.5	65.4	J
3/4	0.55	V-80S	1720	27.5	3.11	2.47	1.24	68.4	500	266	261	76.5	73.1	H

\*\* 1/8 HP is TENV

**Table 5.19b Three Phase, 240/480V, 60Hz, 1800 RPM Synchronous Speed, TEFC - UL Recognized**

Motor Capacity		Frame Size	Full Load (A)			Current				Starting Torque % of FL	Breakdown Torque % of FL	Nominal Efficiency %	Power Factor %	NEMA Code Letter
HP	kW		Rated RPM	Torque		Full Load		No Load % of FL	Starting % of FL					
				in-lbs	N-m	240V	480V							
1/8**	0.1	V-63S	1740	4.53	0.512	0.69	0.35	87.4	429	364	341	61.9	56.3	L
1/4	0.2	V-63M	1740	9.05	1.02	1.16	0.58	83.6	466	335	317	68.2	61	K
1/3	0.25	V-63M	1710	12.3	1.39	1.27	0.63	77.0	429	268	238	69.8	68.1	H
1/2	0.4	V-71M	1750	18.0	2.04	2.27	1.13	83.2	460	328	303	70.4	60.4	K
3/4	0.55	V-80S	1730	27.3	3.09	2.52	1.26	73.4	508	294	285	76.0	69.2	H

\*\* 1/8 HP is TENV

**Table 5.19c Three Phase, 230/460V, 60Hz, 1800 RPM Synchronous Speed, TEFC - CSA Approved**

Motor Capacity		Frame Size	Full Load (A)			Current				Starting Torque % of FL	Breakdown Torque % of FL	Nominal Efficiency %	Power Factor %	NEMA Code Letter
HP	kW		Rated RPM	Torque		Full Load		No Load % of FL	Starting % of FL					
				in-lbs	N-m	230V	460V							
1/8**	0.1	V-63S	1730	4.55	0.514	0.66	0.33	86.1	424	326	308	63.3	60.0	K
1/4	0.2	V-63M	1730	9.10	1.03	1.12	0.56	79.6	464	300	287	69.2	65.1	K
1/3	0.25	V-63M	1700	12.2	1.38	1.24	0.62	72.0	419	237	226	70.1	72.0	G
1/2	0.4	V-71M	1750	18.0	2.03	2.15	1.08	77.7	456	295	276	71.5	65.4	J
3/4	0.55	V-80S	1720	27.5	3.11	2.47	1.24	68.4	500	266	261	76.5	73.1	H

\*\* 1/8 HP is TENV

**Table 5.19d Three Phase, 575V, 60Hz, 1800 RPM Synchronous Speed, TEFC - CSA Approved**

Motor Capacity		Frame Size	Full Load (A)			Current				Starting Torque % of FL	Breakdown Torque % of FL	Nominal Efficiency %	Power Factor %	NEMA Code Letter
HP	kW		Rated RPM	Torque		Full Load		No Load % of FL	Starting % of FL					
				in-lbs	N-m	575V								
1/8**	0.1	V-63S	1720	4.58	0.518	0.28		91.8	464	376	391	65.5	54.1	M
1/4	0.2	V-63M	1730	9.10	1.03	0.48		85.4	458	316	340	69.4	60.1	K
1/3	0.25	V-63M	1710	12.2	1.38	0.52		78.8	423	250	270	71.3	67.5	H
1/2	0.4	V-71M	1700	18.5	2.09	0.79		75.8	468	309	300	75.2	63.1	J
3/4	0.55	V-80S	1700	27.8	3.14	1.00		74.0	530	260	268	75.4	71.4	H

\*\* 1/8 HP is TENV





## Motor Performance Data - EP.NA Motor, 60Hz Operation

Table 5.22 Three Phase, 230/460v, 60Hz, 1800 RPM Synchronous Speed, TEFC

Motor Capacity		Frame Size	Full Load			Current (A)				Starting Torque % of FL	Breakdown Torque % of FL	Nominal Efficiency %	Power Factor %	NEMA Code Letter
HP	kW		Rated RPM	Torque		Full Load		No Load % of FL	Starting % of FL					
				in-lbs	N-m	230V	460V							
1	0.75	N-80M	1730	36.6	4.14	3.06	1.53	62.0	692	343	403	85.5	72.0	K
1.5	1.1	N-90S	1730	53.7	6.07	4.15	2.08	52.1	659	277	341	86.5	76.5	J
2	1.5	N-90L	1730	73.2	8.28	5.61	2.80	52.7	694	284	356	86.5	77.2	J
3	2.2	N-100L	1740	107	12.1	7.66	3.83	47.6	824	317	389	89.5	80.7	K
5	3.7	N-112M	1750	179	20.2	12.3	6.17	44.5	821	244	379	89.5	83.9	K
7.5	5.5	N-132S	1760	264	29.8	17.8	8.90	42.9	1000	290	461	91.7	84.2	L
10	7.5	N-132M	1760	360	40.7	24.4	12.2	36.1	606	193	277	91.7	84.1	G
15	11	N-160M	1770	525	59.3	38.4	19.2	48.0	736	274	369	92.4	77.8	J
20	15	N-160L	1770	716	80.9	47.7	23.8	36.5	828	227	351	93.0	85.0	J
25	18.5	N-180MS	1780	878	99.2	56.9	28.5	31.7	805	245	308	93.6	86.4	J
30	22	N-180M	1780	1040	118	67.4	33.7	28.8	673	206	258	93.6	87.1	G
40	30	N-180L	1780	1420	161	91.6	45.8	29.5	792	242	295	94.1	87.0	J

Table 5.23 Three Phase, 240/480V, 60Hz, 1800 RPM Synchronous Speed, TEFC

Motor Capacity		Frame Size	Full Load			Current (A)				Starting Torque % of FL	Breakdown Torque % of FL	Nominal Efficiency %	Power Factor %	NEMA Code Letter
HP	kW		Rated RPM	Torque		Full Load		No Load % of FL	Starting % of FL					
				in-lbs	N-m	240V	480V							
1	0.75	N-80M	1740	36.4	4.12	3.05	1.52	66.2	723	380	439	85.5	69.2	L
1.5	1.1	N-90S	1740	53.4	6.04	4.09	2.05	56.6	704	310	375	86.5	74.1	J
2	1.5	N-90L	1730	73.2	8.28	5.54	2.77	57.8	722	316	387	86.5	74.5	K
3	2.2	N-100L	1750	106	12.0	7.53	3.77	52.0	911	352	446	89.5	78.4	L
5	3.7	N-112M	1760	178	20.1	12.1	6.06	49.3	886	268	421	89.5	81.7	K
7.5	5.5	N-132S	1760	264	29.8	17.5	8.76	47.6	1060	321	506	91.7	82.0	M
10	7.5	N-132M	1760	360	40.7	23.8	11.9	40.3	652	212	308	91.7	82.2	H
15	11	N-160M	1770	525	59.3	38.7	19.3	54.0	760	305	405	92.4	74.0	K
20	15	N-160L	1770	716	80.9	46.5	23.2	41.0	893	251	387	93.0	83.3	K
25	18.5	N-180MS	1780	878	99.2	55.1	27.6	35.2	881	268	340	93.6	85.3	K
30	22	N-180M	1780	1040	118	64.9	32.4	29.9	748	224	285	93.6	86.5	H
40	30	N-180L	1780	1420	161	88.8	44.4	33.3	867	266	326	94.1	85.9	J

## Motor Performance Data - EP.NA Motor, 60Hz Operation (continued)

Table 5.24 Three Phase, 575V, 60Hz, 1800 RPM Synchronous Speed, TEFC

Motor Capacity		Frame Size	Full Load			Current (A)				Starting Torque % of FL	Breakdown Torque % of FL	Nominal Efficiency %	Power Factor %	NEMA Code Letter
HP	kW		Rated RPM	Torque		Full Load		No Load % of FL	Starting % of FL					
				in-lbs	N-m	575V								
1	0.75	N-80M	1740	36.4	4.12	1.36	72.7	768	430	500	85.5	64.4	M	
1.5	1.1	N-90S	1740	53.4	6.04	1.69	57.8	743	313	386	86.5	74.5	K	
2	1.5	N-90L	1730	73.2	8.28	2.22	52.3	685	272	341	86.5	77.9	J	
3	2.2	N-100L	1740	107	12.1	3.05	47.2	839	322	404	89.5	80.8	K	
5	3.7	N-112M	1750	179	20.2	4.86	42.0	798	230	355	89.5	84.9	J	
7.5	5.5	N-132S	1760	264	29.8	7.12	42.5	957	263	429	91.7	84.7	L	
10	7.5	N-132M	1760	360	40.7	10.1	43.9	704	230	332	91.7	81.3	H	
15	11	N-160M	1760	528	59.7	14.5	41.7	710	237	331	92.4	82.3	H	
20	15	N-160L	1770	716	80.9	19.4	41.1	915	257	396	93.0	83.3	K	
25	18.5	N-180MS	1780	878	99.2	22.8	35.2	916	276	350	93.6	86.1	K	
30	22	N-180M	1780	1040	118	26.8	29.9	779	230	293	93.6	87.2	H	
40	30	N-180L	1780	1420	161	37.0	31.5	857	263	321	94.1	86.1	J	

**Motor Performance Data - IE3 CE Motor, 50Hz Operation**

**Table 5.25 Three Phase, 220/380V, 50Hz, 1500 RPM Synchronous Speed, TEFC**

Motor Capacity		Frame Size	Full Load			Current (A)				Starting Torque % of FL	Breakdown Torque % of FL	Nominal Efficiency %	Power Factor %	NEMA Code Letter
HP	kW		Rated RPM	Torque		Full Load		No Load % of FL	Starting % of FL					
				in-lbs	N-m	220V	380V							
1	0.75	N-80M	1430	44.3	5.01	3.46	2.00	69.5	608	383	402	84.7	67.9	K
1.5	1.1	N-90S	1430	65.0	7.35	4.49	2.59	57.1	637	296	343	85.4	75.1	J
2	1.5	N-90L	1420	89.2	10.1	6.10	3.52	57.1	607	304	338	85.4	75.5	H
3	2.2	N-100L	1440	129	14.6	8.58	4.96	54.8	796	344	418	88.6	78.0	K
4	3.0	N-112S	1430	177	20.0	11.3	6.50	48.1	712	316	365	87.7	80.8	J
5	3.7	N-112M	1460	214	24.2	13.5	7.80	50.7	777	266	378	89.6	81.2	J
5.5	4.0	N-112M	1450	233	26.3	14.4	8.30	47.7	730	266	378	88.9	82.9	J
7.5	5.5	N-132S	1460	318	36.0	-	11.5	42.0	950	316	471	90.6	80.7	L
10	7.5	N-132M	1460	434	49.1	-	15.8	47.2	620	213	315	90.8	79.6	H
15	11	N-160M	1460	636	71.9	-	22.3	40.4	578	200	283	91.4	81.6	G
20	15	N-160L	1470	862	97.4	-	30.5	45.2	649	230	304	92.6	80.6	H
25	18.5	N-180MS	1480	1060	119	-	35.6	38.8	772	245	338	94.0	83.5	J
30	22	N-180M	1480	1260	142	-	41.9	32.9	656	206	284	93.5	85.4	G
40	30	N-180L	1480	1710	194	-	58.9	41.4	631	239	344	94.3	82.6	H

**Table 5.26 Three Phase, 230/400V, 50Hz, 1500 RPM Synchronous Speed, TEFC**

Motor Capacity		Frame Size	Full Load			Current (A)				Starting Torque % of FL	Breakdown Torque % of FL	Nominal Efficiency %	Power Factor %	NEMA Code Letter
HP	kW		Rated RPM	Torque		Full Load		No Load % of FL	Starting % of FL					
				in-lbs	N-m	230V	400V							
1	0.75	N-80M	1440	44.0	4.97	3.54	2.05	75.8	643	423	446	84.6	62.7	L
1.5	1.1	N-90S	1440	64.5	7.29	4.50	2.60	64.4	672	336	387	85.6	71.1	K
2	1.5	N-90L	1430	88.6	10.0	6.17	3.56	65.3	631	338	375	85.8	72.3	J
3	2.2	N-100L	1450	128	14.5	8.56	4.95	63.3	839	382	465	88.7	74.1	L
4	3.0	N-112S	1440	176	19.9	11.2	6.45	56.0	767	352	419	87.9	76.9	K
5	3.7	N-112M	1460	214	24.2	13.7	7.90	58.8	805	294	420	89.0	77.5	K
5.5	4.0	N-112M	1460	231	26.2	14.4	8.30	56.0	768	273	388	89.1	78.8	K
7.5	5.5	N-132S	1460	318	36.0	-	11.6	59.5	985	351	524	90.6	76.2	M
10	7.5	N-132M	1460	434	49.1	-	16.0	54.5	739	206	350	91.2	75.5	K
15	11	N-160M	1470	632	71.5	-	22.2	61.2	714	257	378	91.5	73.0	J
20	15	N-160L	1480	856	96.8	-	30.6	53.3	681	256	338	92.5	76.3	J
25	18.5	N-180MS	1480	1060	119	-	35.4	46.0	817	272	375	93.9	80.1	K
30	22	N-180M	1480	1260	142	-	40.9	39.9	707	227	314	93.8	82.7	H
40	30	N-180L	1480	1710	194	-	59.1	49.7	767	265	382	94.0	78.2	J

**Motor Performance Data - IE3 CE Motor, 50Hz Operation (continued)**

**Table 5.27 Three Phase, 240/415V, 50Hz, 1500 RPM Synchronous Speed, TEFC**

Motor Capacity		Frame Size	Full Load			Current (A)				Starting Torque % of FL	Breakdown Torque % of FL	Nominal Efficiency %	Power Factor %	NEMA Code Letter
HP	kW		Rated RPM	Torque		Full Load		No Load % of FL	Starting % of FL					
				in-lbs	N-m	240V	415V							
1	0.75	N-80M	1450	43.7	4.94	3.65	2.11	80.1	629	461	484	84.1	59.4	L
1.5	1.1	N-90S	1440	64.5	7.29	4.57	2.64	69.7	688	368	422	85.5	67.4	K
2	1.5	N-90L	1440	88.0	9.95	6.29	3.63	72.2	642	366	406	85.4	67.3	K
3	2.2	N-100L	1450	128	14.5	8.83	5.10	69.3	844	412	502	88.3	69.3	M
4	3.0	N-112S	1440	176	19.9	11.3	6.55	62.5	785	387	458	87.9	73.2	L
5	3.7	N-112M	1460	214	24.2	13.9	8.00	65.6	827	319	453	89.2	72.7	L
5.5	4.0	N-112M	1460	231	26.2	14.5	8.35	62.9	792	294	418	89.0	74.8	K
7.5	5.5	N-132S	1470	316	35.7	-	11.9	67.1	1000	378	564	90.2	72.0	N
10	7.5	N-132M	1470	431	48.7	-	16.2	61.4	660	254	378	90.6	71.1	J
15	11	N-160M	1470	632	71.5	-	22.4	53.2	648	249	354	91.6	74.6	H
20	15	N-160L	1480	856	96.8	-	31.2	59.9	693	275	364	92.2	72.3	J
25	18.5	N-180MS	1490	1050	119	-	35.7	52.4	840	292	404	93.8	76.7	K
30	22	N-180M	1480	1260	142	-	40.8	45.8	735	245	339	93.6	80.2	J
40	30	N-180L	1480	1710	194	-	60.2	55.6	781	285	411	93.6	74.2	K

## Motor Selection Considerations for Inverter (VFD) Operation

### Benefits:

**Operating a three-phase AC Motor with an Inverter (Variable Frequency Drive – VFD) brings benefits to the design of a process control system:**

- Extending a motor's acceleration time (soft starting) can greatly reduce motor starting current levels. Inrush current is limited typically to 150% of a motor's ampere ratings.
- Controlled and extended acceleration and deceleration rates reduce or eliminate the stress of high torque demands on the motor, reducer and driven load.
- Motor speed can be infinitely adjusted electronically to operate the process at the optimum speed.
- Full-rated motor torque levels can be applied to the load over as much as a 10:1 speed range (6 to 60 Hz, approximately 180 to 1800 RPM motor shaft speed). *(See note on next page about Constant Torque Speed Range)*
- Overspeed operation: within the operating limits of the motor, reducer and driven load, motor speed range can be extended beyond 60 Hz (1800 RPM). *(See note on next page about Constant Horsepower Speed Range)*
- Regulation of motor speed and/or torque without additional feedback devices.
- A properly sized and adjusted Sensorless Flux Vector AC drive can regulate motor shaft speed to almost eliminate motor slip over the motor's entire loading range.
- Electronic programmable motor torque limiting.
- Electronic overload and short circuit protection for the motor.
- Electronic Reversing: upon command, a VFD will follow preprogrammed deceleration rate to stop motor and then follow acceleration rate to bring motor to commanded speed in reverse direction. No additional power or mechanical components needed to reverse the motor.
- Motor braking (up to 150% of motor rated torque level with optional VFD components).  
**NOTE: VFDs do not provide HOLDING brake capability.** VFDs can be used to sequence a motor-mounted holding brake.
- Many VFDs include basic process control functions and easily interface with Programmable Logic Controllers for more advance process control schemes.
- Serial communication capability for remote monitoring of motor, VFD and process status.
- Within a small limited HP range, VFDs can be selected to power a three-phase 230V motor from a single phase 240V power feed.

### Constant Torque Operation:

For most gearmotor applications, a constant-torque rated VFD is required.

Constant-torque rated VFDs carry various manufacturer designations:

- Constant Torque, Heavy Duty or Normal Duty.

All constant-torque rated VFDs carry a 60-second ampere overload capability level of 150% of the VFD's continuous output ampere rating.

VFDs that offer a 110% or 120% 60-second ampere overload capability are designed for variable-torque type loads like fans and pumps with propellers and impellers and are most likely undersized for gearmotor applications.

When a VFD applies power to a motor, it simultaneously varies both the applied motor voltage level (amplitude) and the motor frequency (Hz) so that the torque delivered at the motor shaft can be held constant from a motor's base speed (typically 60 Hz) down to below 20 Hz.

The lower frequency limit is dependent on the design complexity of the VFD:

Basic V/Hz control (6 Hz), Sensorless Vector control (0.6 Hz), full Flux Vector control (0.06 Hz).

To achieve the Vector levels of motor control, the VFD must control only one motor, the VFD and motor must be closely matched in power ratings and the VFD must be properly adjusted, perhaps even "tuned" to the motor.

**Most electrical motors are not designed to operate continuously at such low frequencies.**

*(See note on next page about Constant Torque Speed Range)*

## Motor Selection Considerations for Inverter (VFD) Operation (cont.)

### Constant Horsepower (CHP) Operation:

It may be possible to configure a VFD to operate a motor at speeds beyond the motor's base frequency (typically 60 Hz – 1800 RPM).

**To avoid unsafe and unreliable operation, never power a motor, reducer or a driven load beyond the manufacturer's maximum safe operating speed.**

Consult Sumitomo factory for the HBB reducer maximum operating speed rating.

Consult the manufacturer of the driven load for its maximum operating speed rating.

A motor's full-load power rating is the product of its full-load torque rating and its base speed rating.

A motor's power rating does not increase when it is operated above its base speed.

Operation above a motor's base frequency is called Constant Horsepower (CHP) operation.

When a motor is operated above its base frequency, its output torque capability drops as its frequency is increased.

### Constant Torque Speed Range (CTSR):

Most motors are not designed to operate for prolonged periods of time at low speed (typically below 20 Hz).

Most motors (i.e TEFC) depend upon a motor shaft-mounted fan for ventilation.

When the motor is operating at low speed, this motor shaft-mounted fan does not provide sufficient air movement to keep the motor's internal temperature within proper operating limits.

Operating a motor continuously beyond its CTSR can result in premature motor failure.

Be sure to properly configure the VFD's motor overload protection to match the motor type.

Motors listed for control by a VFD at low speed have been specifically designed to dissipate the heat through means other than the motor shaft-mounted fan.

A motor's ability to operate continuously at low speed is defined by its CTSR or Constant Torque Speed Range.

Examples of a CTSR rating are: 4:1, 6:1, 10:1.

A motor with a CTSR rating of 4:1 can operate continuously at 15 Hz (60 Hz / 4 = 15 Hz).

A motor with a CTSR rating of 10:1 can operate continuously at 6 Hz (60 Hz / 10 = 6 Hz).

See "Constant Torque Speed Ranges: Gearmotors" on page 3.8 for the Sumitomo motor constant torque speed rating (CTSR).

Consult the instructional material supplied with the VFD for additional important information.

## Standard Wiring Diagrams

Illustrated below are the wiring diagrams for our standard motors. For additional information please refer to the motor name plate. Due to changes in design features, this diagram may not always agree with that on the motor. If different, the motor diagram found inside the conduit box cover should be used.

### Three-Phase Fractional and EP.NA Motor

**Table 5.28 Wiring Configuration for 230/460V, 60Hz and 575V, 60Hz by EP.NA Motor**

Motor HP x P	230/460V, 60Hz			575V, 60Hz		
	Internal	No. of Leads	Diagram	Internal	No. of Leads	Diagram
1/8 x 4	WYE	9	9-Lead WYE	WYE	3	3-Lead
1/4 x 4						
1/3 x 4						
1/2 x 4						
3/4 x 4						
1 x 4						
1.5 x 4						
2 x 4						
3 x 4						
5 x 4						
7.5 x 4	DELTA	9	9-Lead DELTA	DELTA	3	3-Lead
10 x 4						
15 x 4						
20 x 4						
25 x 4						
30 x 4						
40 x 4						

**Figure 5.9 9-Lead - WYE**

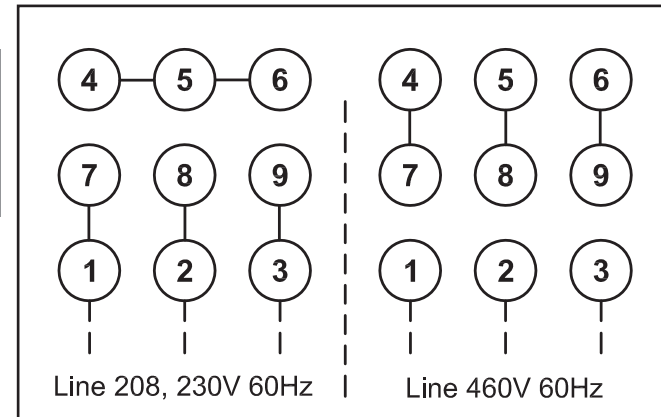

**Figure 5.10 9-Lead - DELTA**

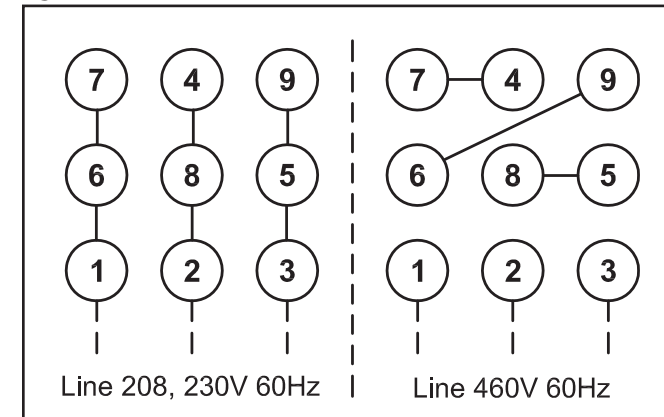

**Figure 5.11 3-Lead - SINGLE**

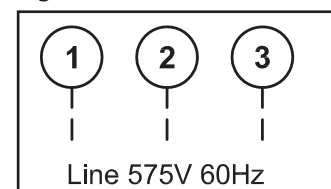

## Three-Phase IE3 CE Motors

**Table 5.29 Wiring Configuration by IE3 CE Motor**

Motor kW x P	Voltage Configuration	Wiring Diagram
0.1 x 4	220/380V, 50Hz Three Phase	DELTA-WYE
0.2 x 4		
0.25 x 4		
0.4 x 4		
0.55 x 4		
.75 x 4		
1.1 x 4		
1.5 x 4		
2.2 x 4		
3.0 x 4		
3.7 x 4	380V, 50Hz Three Phase	WYE-Start DELTA-Run
5.5 x 4		
7.5 x 4		
11 x 4		
15 x 4		
18.5 x 4		
22 x 4		
30 x 4		

**Figure 5.12 DELTA-WYE Diagram**

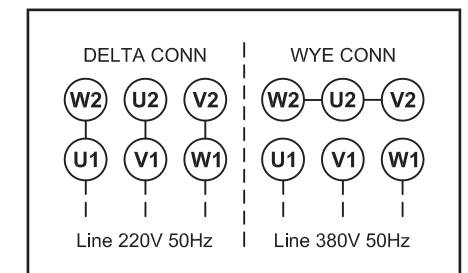

**Figure 5.13 WYE-Start DELTA-Run Diagram**

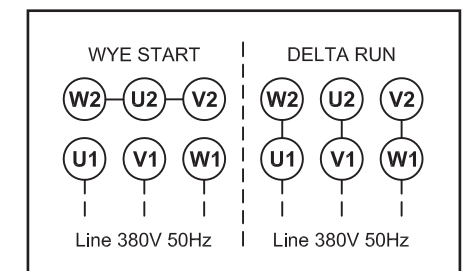

## Motor Thermal Rating for Cyclic Applications

Motors operated across the line with frequent starts and stops will generate excess heat from high starting current. The capacity for the motor to handle this extra heating will depend on the combination of strating frequency, the load inertia, and time duty. Calculate the C x Z value from the formulas below for inertial factor (C) and starts per hour (Z) and compare the C x Z results against the permissible values for the intergral motor ratings in the Motor Thermal Rating Table

**Table 5.30 Motor Thermal Rating Table**

Motor Power HP (kW)	Allowable C x Z				Motor Inertia lb-in <sup>2</sup> (kg-m <sup>2</sup> )	
	below 35% ED <sup>[1]</sup>	35% ~ 50% ED <sup>[1]</sup>	50% ~ 80% ED <sup>[1]</sup>	80% ~ 100% ED <sup>[1]</sup>	Standard	with Brake
1/8 (0.1)	3200	3000	2000	1200	1.11 (0.000325)	1.2 (0.00035)
1/4 (0.2)	2200	2800	2800	2500	1.71 (0.0005)	1.88 (0.00055)
1/3 (0.25)	2200	2800	2800	2500	1.71 (0.0005)	1.88 (0.00055)
1/2 (0.4)	1800	2200	1500	1500	2.22 (0.00065)	2.31 (0.000675)
3/4 (0.55)	1800	2200	1500	1500	3.45 (0.00101)	3.79 (0.00111)
1 (0.75)	1400	1400	800	500	8.03 (0.00235)	8.82 (0.00258)
1.5 (1.1)	1400	1400	800	500	11.5 (0.00337)	13.5 (0.00396)
2 (1.5)	1200	1200	500	400	13.4 (0.00391)	15.4 (0.0045)
3 (2.2)	1000	900	400	200	30.1 (0.0088)	33.4 (0.00978)
5 (3.7)	800	800	800	700	66.3 (0.0194)	71.4 (0.0209)
7.5 (5.5)	300	300	200	150	99.4 (0.0291)	105 (0.0306)
10 (7.5)	400	350	300	300	140 (0.0409)	154 (0.045)
15 (11)	200	200	150	150	192 (0.0561)	206 (0.0602)
20 (15)	100	90	78	68	340 (0.0995)	393 (0.115)
25 (18.5)	75	65	55	50	875 (0.256)	926 (0.271)
30 (22)	75	65	55	50	875 (0.256)	926 (0.271)
40 (30)	55	40	17	10	1110 (0.326)	1170 (0.342)

Note: [1] % ED = Duty Cycle.

The calculated C x Z value (steps 1 – 3 outlined below) should be less than the allowable value listed in Motor Thermal Rating table above.

**1. Obtain the C value:**

$$C = \frac{I_M + I_L}{I_M}$$

$I_M$  = Moment of Inertia of the Motor.  
 $I_L$  = Moment of Inertia of the Load as seem from the motor shaft.

**2. Obtain the Z value (number of starts per hour):**

- (a) Assume that one operating period consists of “on-time”  $t_a$  (sec.), “off-time”  $t_b$  (sec.) and the motor is started  $nr$  (times/cycle).

$$Z_r = \frac{3600 \cdot nr}{t_a + t_b} \text{ (times/hour)}$$

- (b) When inching,  $ni$  (times/cycle) is included in 1 cycling ( $t_a+t_b$ ), the number of inching times per hour  $Z_i$ , is then included in the number of starts.

$$Z_i = \frac{3600 \cdot ni}{t_a + t_b} \text{ (times/hour)}$$

- (c) Calculate Z by adding  $Z_r$  to  $Z_i$  by the following formula.

$$Z = Z_r + \frac{1}{2} \cdot Z_i = \frac{3600}{t_a + t_b} \cdot \left( nr + \frac{1}{2} ni \right) \text{ (times/hour)}$$

**3. Calculate C x Z (the product of C and Z)**

Use the value of C obtained in Step (1) and value of Z obtained in Step (2).

**4. Obtain the duty cycle %ED and compare calculated C x Z in the appropriate column from Motor Thermal Rating Table.**

$$\%ED = \frac{t_a}{t_a + t_b} \cdot 100$$

$t_a$  = on-time  
 $t_b$  = off-time

## Brakemotor Characteristics

The brakemotor on Cyclo® HBB gearmotors operates with direct current supplied by a dual voltage rectifier for 230/460V, or single voltage rectifier/power module for other noted voltages. Rectifier or power module is mounted in the motor conduit box.

When used for outdoor installations, standard brakemotor must be protected by a cover. Such covers are available from the factory, please inquire when ordering.

Note: Advise the factory when ordering if you require brake torque greater or lesser than those shown as standard in the Brakemotor Characteristics table below.

## Brake Characteristics

**Table 5.31 Brake Characteristics - Standard torque, Delay Time, Work Capacity**

Brake Model	Motor Capacity		Standard Braking Torque ft - lbs (N - m)	Braking Delay Time (sec)			Brake Work Capacity		
				Normal Braking Action		Fast Braking Action	Allowable $E_0$ (J/min)	Gap Adjust (x 10 <sup>7</sup> J)	Total $E_1$ (x 10 <sup>7</sup> J)
	HP x 4P	kW x 4P	Standard Wiring	Inverter Wiring <sup>[1]</sup>					
FB-01A1	1/8	0.1	0.7 (1.0)	0.15 ~ 0.2	0.08 ~ 0.12	0.015 ~ 0.02	1080	2.6	6.7
FB-02A1	1/8 ~ 1/3	0.1 ~ 0.25	1.4 (2.0)						
FB-05A1	1/4 ~ 1/2	0.2 ~ 0.4	2.9 (4.0)	0.1 ~ 0.15	0.03 ~ 0.07	0.01 ~ 0.015	1620	7.0	33.1
FB-1D	1/2	0.4	5.8 (7.5)	0.2 ~ 0.3	0.1 ~ 0.15	0.01 ~ 0.02			
FB-2D	3/4	0.55	11 (15)						
FB-3D	3/4	0.55	16 (22)	0.3 ~ 0.4	0.15 ~ 0.2	0.01 ~ 0.03	2580	6.8	29.5
FB-1E	1	0.75	5.5 (7.5)	0.25 ~ 0.45	0.15 ~ 0.25		2580	11.6	38.7
FB-1HE	1.5	1.1	8.0 (11)	0.45 ~ 0.65	0.25 ~ 0.35	3360	20.8	46.3	
FB-2E	2	1.5	11 (15)	0.35 ~ 0.55	0.15 ~ 0.25				
FB-3E	3	2.2	16 (22)	0.75 ~ 0.95	0.4 ~ 0.5	5720	26.3	105.3	
FB-5E	5	3.7	30 (40)	1.1 ~ 1.3	0.4 ~ 0.5				
FB-8E	7.5	5.5	40 (55)	1.0 ~ 1.2	0.3 ~ 0.4	6900	57.4	382.8	
FB-10E	10	7.5	59 (80)	1.8 ~ 2.0	0.6 ~ 0.7				
FB-15E	15	11	80 (110)	1.6 ~ 1.8	0.5 ~ 0.6	10800	110.2	551.1	
FB-20	20	15	110 (150)	-	-				0.06 ~ 0.14 <sup>[2]</sup>
FB-30	25	18.5	140 (190)	-	-	0.03 ~ 0.11 <sup>[2]</sup>	22440	191.6	1150
	30	22	160 (220)						
	40	30	150 (200)						

Notes: [1] Also applies to wiring where brake is powered separately from the motor leads.

[2] Values shown for 200V Class and 400V Class Brakes. Please consult factory for 575V Brakes.

**Brake Characteristics**

**Table 5.32 Brake Maintenance - Brake Gap, Brake Lining Thickness**

Brake Model	Brake Gap			Brake Lining Thickness	
	Spec. (Initial) inch (mm)	Limit inch (mm)	Adjustment Method	Spec. (Initial) inch (mm)	Limit inch (mm)
FB-01A1	0.008 ~ 0.014 (0.2 ~ 0.35)	0.020 (0.5)	Twist Detent	0.276 (7.0)	0.256 (6.5)
FB-02A1					
FB-05A1					
FB-1D	0.012 ~ 0.016 (0.3 ~ 0.4)	0.024 (0.60)	Shim	0.347 (8.8)	0.236 (6.0)
FB-2D					0.307 (7.8)
FB-3D					0.315 (8.0)
FB-1E					0.307 (7.8)
FB-1HE					0.315 (8.0)
FB-2E	0.010 ~ 0.014 (0.25 ~ 0.35)	0.030 (0.75)		0.355 (9.0)	0.331 (8.4)
FB-3E					
FB-5E	0.014 ~ 0.018 (0.35 ~ 0.45)	0.040 (1.0)	Nut	0.433 (11.0)	0.394 (10.0)
FB-8E					0.236 (6.0)
FB-10E					0.276 (7.0)
FB-15E					0.472 (12.0)
FB-20	0.024 ~ 0.028 (0.6 ~ 0.7)	0.059 (1.5)		0.630 (16.0)	0.472 (12.0)
FB-30					

**Brakemotor: Brake Current Rating**

**Table 5.33 Brake Current for Standard Fractional Motor and AF-Motor (AV)**

Brake Model	230VAC, 60Hz			460VAC, 60Hz			575VAC, 60Hz		
	Vdc (V)	Idc (A)	Iac (A)	Vdc (V)	Idc (A)	Iac (A)	Vdc (V)	Idc (A)	Iac (A)
FB-01A1	207VDC Full Wave	0.05	0.06	207VDC Half Wave	0.05	0.04	259VDC Half Wave	0.05	0.03
FB-02A1		0.08	0.1		0.08	0.06		0.09	0.07
FB-05A1		0.1	0.1		0.1	0.1		0.1	0.1
FB-1D		0.1	0.1		0.1	0.1		0.1	0.1
FB-2D		0.2	0.2		0.2	0.2		0.2	0.2
FB-3D									

**Table 5.34 Brake Current for EP.NA Motor**

Brake Model	230VAC, 50/60Hz			240VAC, 50/60Hz			460VAC, 50/60Hz			480VAC, 50/60Hz		
	Vdc (V)	Idc (A)	Iac (A)	Vdc (V)	Idc (A)	Iac (A)	Vdc (V)	Idc (A)	Iac (A)	Vdc (V)	Idc (A)	Iac (A)
FB-1E	207VDC Full Wave	0.1	0.1	216VDC Full Wave	0.1	0.1	207VDC Half Wave	0.1	0.1	216VDC Half Wave	0.1	0.1
FB-1HE		0.2	0.2		0.2	0.2		0.2	0.2			
FB-2E		0.2	0.2		0.2	0.2		0.2	0.2			
FB-3E		0.2	0.2		0.2	0.2		0.2	0.2			
FB-5E		0.4	0.4		0.4	0.4		0.4	0.4			
FB-8E		0.4	0.4		0.4	0.4		0.4	0.4			
FB-10E												
FB-15E												
FB-20	207VDC /104VDC Module <sup>[1]</sup>	2.0/1.0 <sup>[2]</sup>	2.0/0.8 <sup>[2]</sup>	216VDC /108VDC Module <sup>[2]</sup>	2.1/1.1 <sup>[2]</sup>	2.1/0.8 <sup>[2]</sup>	414VDC /207VDC Module <sup>[1]</sup>	1.0/0.5 <sup>[2]</sup>	1.0/0.4 <sup>[2]</sup>	432VDC /216VDC Module <sup>[1]</sup>	1.0/0.5 <sup>[2]</sup>	1.0/0.4 <sup>[2]</sup>
FB-30												

**Table 5.35 Brake Current for EP.NA Motor 575V**

Brake Model	575VAC, 50/60Hz		
	Vdc (V)	Idc (A)	Iac (A)
FB-1E	259VDC Half Wave	0.1	0.1
FB-1HE		0.2	0.2
FB-2E		0.2	0.2
FB-3E		0.2	0.2
FB-5E		0.4	0.3
FB-8E		0.4	0.3
FB-10E			
FB-15E			
FB-20	259VDC Half Wave	0.4	0.3
FB-30			

**Notes:** [1] Power module type brake control generates two voltage levels--1) high excitation voltage for initial release, and 2) lower holding voltage. [2] 2 brake current values shown corresponding to the two voltage levels from power module--1) excitation current on initial power up, and 2) holding current. Brake coil design will be specific to brake voltage specified at time of order. Check motor nameplate, to determine brake voltage rating. FB-20 and FB-30 Brake Coil and Power Module come in two voltage ranges--1) 200-240VAC, and 2) 380-480VAC.

# Motor continued

**Table 5.36 Brake Current for Fractional Motor CE Motor**

Brake Model	220VAC, 50Hz			230VAC, 50Hz			380VAC, 50Hz			400VAC, 50Hz		
	Vdc (V)	Idc (A)	Iac (A)	Vdc (V)	Idc (A)	Iac (A)	Vdc (V)	Idc (A)	Iac (A)	Vdc (V)	Idc (A)	Iac (A)
FB-01A1	99VDC Half Wave	0.13	0.12	104VDC Half Wave	0.13	0.12	171VDC Half Wave	0.06	0.04	180VDC Half Wave	0.06	0.04
FB-02A1		0.2	0.2		0.2	0.2		0.08	0.07		0.08	0.07
FB-05A1		0.3	0.2		0.2	0.2		0.1	0.1		0.1	0.1
FB-1D												

**Table 5.37 Brake Current for IE3 CE Motor**

Brake Model	220VAC, 50Hz			230VAC, 50Hz			380VAC, 50Hz			400VAC, 50Hz		
	Vdc (V)	Idc (A)	Iac (A)	Vdc (V)	Idc (A)	Iac (A)	Vdc (V)	Idc (A)	Iac (A)	Vdc (V)	Idc (A)	Iac (A)
FB-1E	99VDC Half Wave	0.2	0.2	104VDC Half Wave	0.2	0.2	171VDC Half Wave	0.1	0.1	180VDC Half Wave	0.1	0.1
FB-1HE		0.5	0.4		0.5	0.4		0.2	0.2		0.2	0.2
FB-2E		0.6	0.5		0.6	0.5		0.3	0.2		0.3	0.2
FB-3E												
FB-4E		1	0.7		1	0.8		0.4	0.3		0.4	0.3
FB-5E												
FB-8E												
FB-10E		1.1	0.9		1.2	0.9		0.5	0.4		0.5	0.4
FB-15E												
FB-20		198VDC	2.0/1.0 <sup>[2]</sup>		2.0/0.8 <sup>[2]</sup>	207VDC		2.0/1.0 <sup>[2]</sup>	2.0/0.8 <sup>[2]</sup>		342VDC	0.8/0.4 <sup>[2]</sup>
FB-30	/99VDC Module <sup>[1]</sup>	/104VDC Module <sup>[1]</sup>		/171VDC Module <sup>[1]</sup>		/180VDC Module <sup>[1]</sup>						

## Brakemotor: Optional Brake Torques

**Table 5.38 Standard Brake Models**

Brake Model	Motor Capacity			Motor Frame Size	Braking Torque ft-lbs (N-m)					
	Model	HP x 4P (ST)	HP x 4P (AV)		kW x 4P (ST)	Standard	Optional			
FB-01A1	1/8	-	-	0.1	V-63S	0.7 (1.0)	0.25 (0.34)	0.3 (0.4)	0.4 (0.54)	0.48 (0.65)
							0.6 (0.8)	0.7 (1.0)	1.0 (1.4)	-
FB-02A1	1/4 - 1/3	1/8	-	0.2 - 0.25	V-63M, VA-63S	1.4 (2.0)	0.48 (0.65)	0.6 (0.8)	0.7 (1.0)	1.0 (1.4)
							1.4 (2.0)	1.9 (2.6)	2.3 (3.1)	-
FB-05A1	1/2	1/4 - 1/3	-	0.37	V-71M VA-63M	2.9 (4.0)	0.7 (1.0)	1.0 (1.4)	1.4 (2.0)	-
							1.9 (2.6)	2.3 (3.1)	-	-
FB-1D	3/4	1/2	-	0.55	V-80S VA-71M	5.8 (7.5)	2.7 (3.7)	3.9 (5.3)	-	-
							4.6 (6.2)	6.9 (9.4)	7.7 (10)	-
FB-2D	-	3/4	-	-	VA-80S	11 (15)	3.6 (4.9)	4.3 (5.8)	5.1 (6.9)	7.2 (9.8)
							8.7 (12)	13 (18)	14 (19)	-
FB-1E	1	1	1	0.75	N-80M	5.5 (7.5)	2.2 (3.0)	3.0 (4.0)	4.0 (5.5)	7.4 (10)
FB-1HE	1.5	-	-	1.1	N-90S	8.0 (11)	-	3.7 (5.0)	5.5 (7.5)	11 (15)
FB-2E	2	1.5	1.5	1.5	N-90L	11 (15)	3.7 (5.0)	5.5 (7.5)	8.0 (11)	15 (20)
FB-3E	3	2	2	2.2	N-100L	16 (22)	4.4 (6.0)	7.4 (10)	11 (15)	22 (30)
FB-5E	5	3	3	3.7	N-112M	30 (40)	7.4 (10)	15 (20)	22 (30)	40 (55)
FB-8E	7.5	5	5	5.5	N-132S	40 (55)	15 (20)	22 (30)	30 (40)	53 (72)
FB-10E	10	7.5	7.5	7.5	M-132M	59 (80)	15 (20)	30 (40)	44 (66)	80 (110)
FB-15E	15	10	10	11	M-160M	80 (110)	29 (40)	44 (60)	59 (80)	110 (150)
FB-20	20	15 - 20	-	15	N-160L	110 (150)	44 (60)	63 (85)	74 (100)	89 (120)
							130 (175)	160 (220)	-	-
FB-30	25	25	-	18.5	N180MS	140 (190)	44 (60)	74 (100)	89 (120)	110 (150)
							130 (175)	-	-	-
							63 (85)	89 (120)	110 (150)	130 (175)
	30	30	30	22	N-180M	160 (220)	74 (100)	120 (160)	-	-
	40	40	40	30	N-180L	150 (200)	74 (100)	120 (160)	-	-

**Notes:** [1] Power module type brake control generates two voltage levels--1) high excitation voltage for initial release, and 2) lower holding voltage.

[2] 2 brake current values shown corresponding to the two voltage levels from power module--1) excitation current on initial power up, and 2) holding current.

Brake coil design will be specific to brake voltage specified at time of order. Check motor nameplate, to determine brake voltage rating.

FB-20 and FB-30 Brake Coil and Power Module come in two voltage ranges--1) 200-240VAC, and 2) 380-480VAC.

ST - Standard Motor, AV - Inverter Motor



## Brakemotor Standard Wiring Connection, EP.NA Motor

Models FB-01A1 through FB-15E, 230/460V, 60Hz or 575V, 60Hz (Fractional through 15 HP)

Normal Brake Action, 230V or 575V Brake

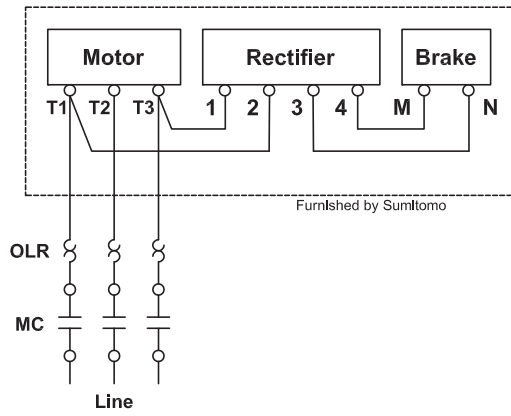

Fast Brake Action, 230V or 575V Brake

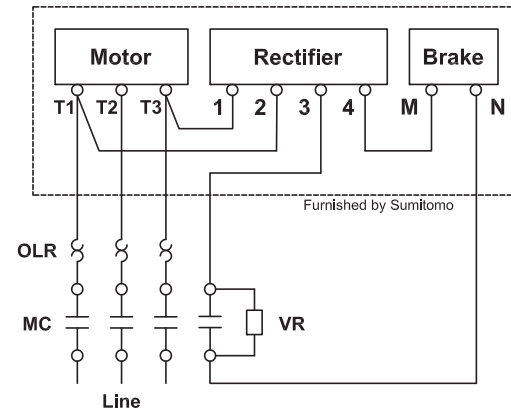

Normal Brake Action, 460V Brake

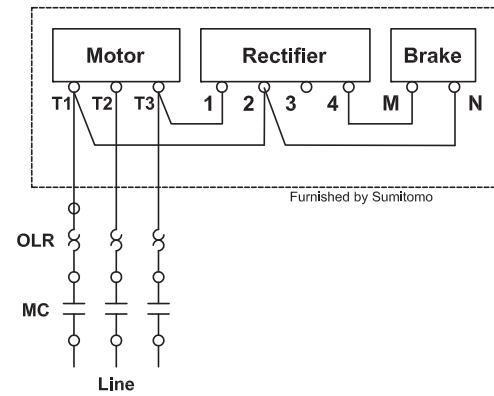

Fast Brake Action, 460V Brake

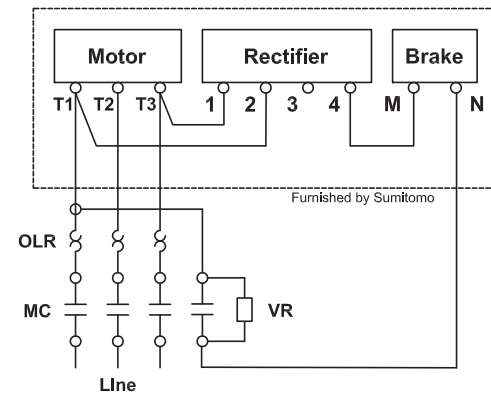

**Key:**  
**MC:** Motor Contactor  
**OLR:** Overload or Thermal Relay  
**VR:** Varistor (protective device, refer to Varistor Specification Table)

Table 5.39 Varistor Specification Table

Operating Voltage		190-230V	380-460V	575V
Varistor Rated Voltage		AC260-300V	AC510V	AC604V
Varistor Voltage		430-470V	820V	1000V
Rated Watt	FB-01A1, 02A1, 05A1	Over 0.4W	Over 0.4W	Over 0.4W
	FB-1E, 1D	Over 0.6W	Over 0.6W	Over 0.4W
	FB-1HE, 2E, 2D, 3E	Over 1.5W	Over 1.5W	Over 0.6W
	FB-5E, 8E, 10E, 15E	Over 1.5W	Over 1.5W	Over 1.5W

## Brakemotor Inverter Wiring Connection, EP.NA Motor

Models FB-01A1 through FB-15E, 230/460V, 60Hz or 575V, 60Hz

Normal Brake Action, 230V or 575V Brake

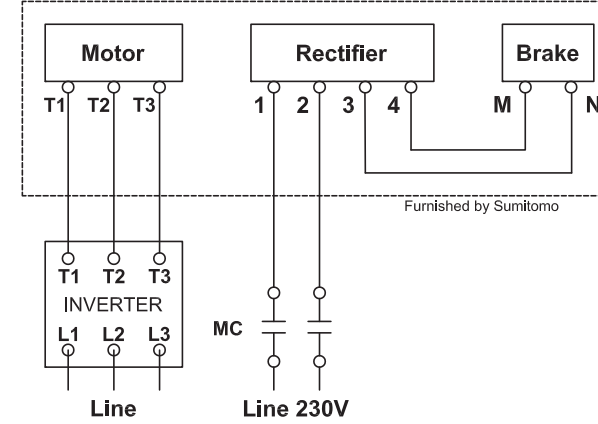

Fast Brake Action, 230V or 575V Brake

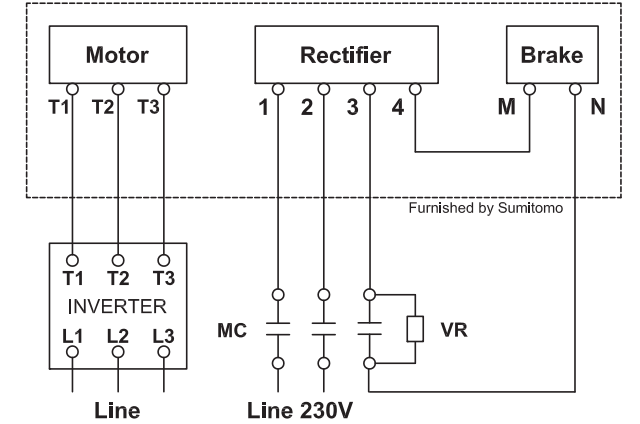

Normal Brake Action, 460V Brake

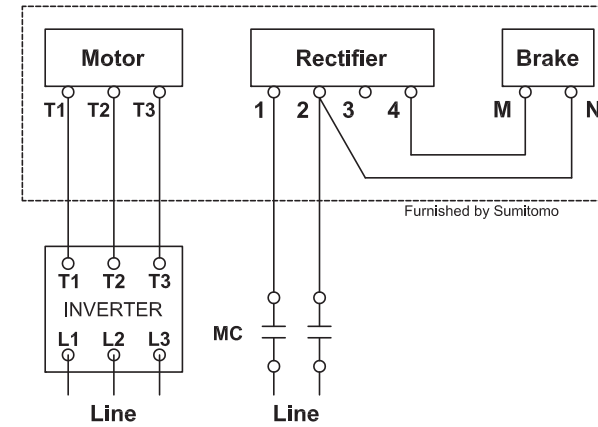

Fast Brake Action, 460V Brake

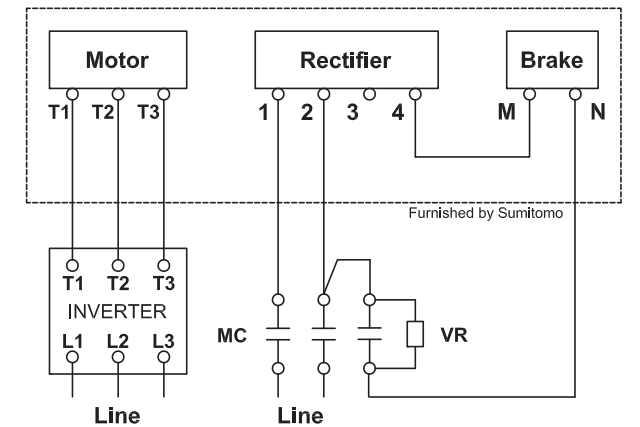

**Key:**  
**MC:** Motor Contactor  
**OLR:** Overload or Thermal Relay  
**VR:** Varistor (protective device, refer to Varistor Specification Table)

Table 5.40 Varistor Specification Table

Operating Voltage		190-230V	380-460V	575V
Varistor Rated Voltage		AC260-300V	AC510V	AC604V
Varistor Voltage		430-470V	820V	1000V
Rated Watt	FB-01A1, 02A1, 05A1	Over 0.4W	Over 0.4W	Over 0.4W
	FB-1E, 1D	Over 0.6W	Over 0.6W	Over 0.4W
	FB-1HE, 2E, 2D, 3E	Over 1.5W	Over 1.5W	Over 0.6W
	FB-5E, 8E, 10E, 15E	Over 1.5W	Over 1.5W	Over 1.5W

# Standard Wiring Connection for IE3 CE Motors

Models FB-01A1 through FB-5E, 220/380V, 50Hz

Normal Brake Action, 220V Motor, 220V Brake

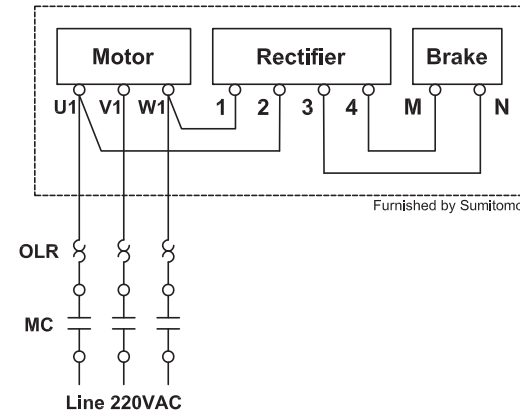

Fast Brake Action, 220V Motor, 220V Brake

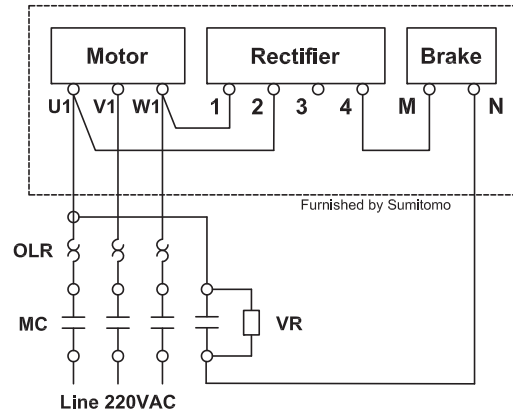

Normal Brake Action, 380V Motor, 220V Brake, Tapped

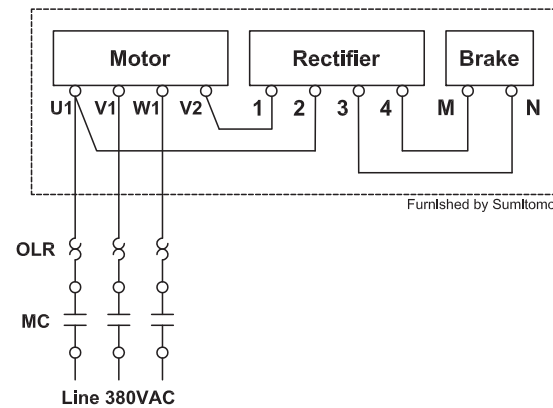

Fast Brake Action, 380V Motor, 220V Brake, Tapped

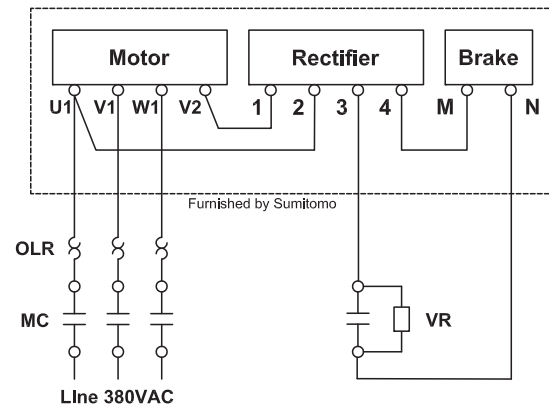

Normal Brake Action, 380V Motor, 220V Brake, Separated

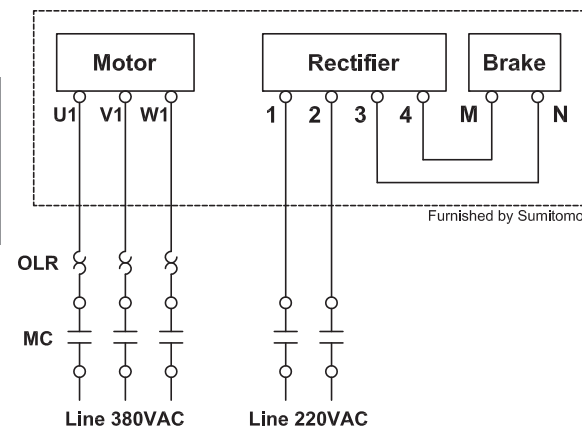

Fast Brake Action, 380V Motor, 220V Brake, Separated

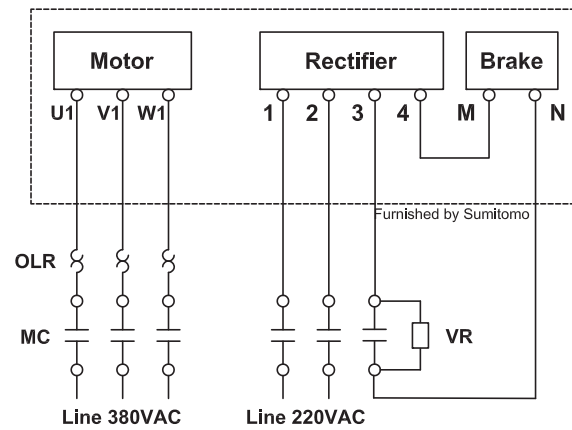

**Key:**  
**MC:** Motor Contactor  
**OLR:** Overload or Thermal Relay  
**MCB:** Magnetic Circuit Breaker  
**VR:** Varistor (protective device, refer to Varistor Specification Table on page 5.39)

# Standard Wiring Connection for IE3 CE Motors (continued)

Models FB-8E through FB-15E, 380V, 50Hz

Normal Brake Action, 380V Motor, 380V Brake

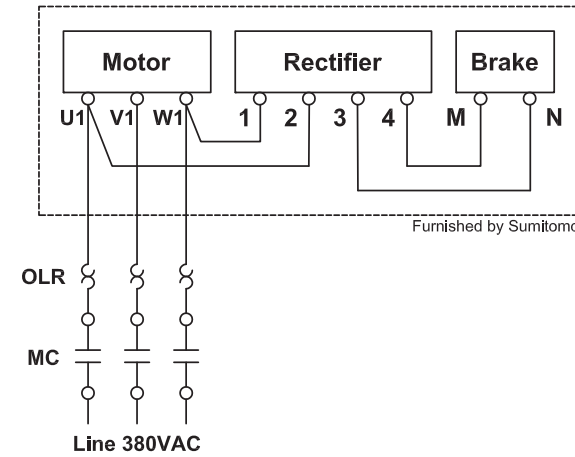

Fast Brake Action, 380V Motor, 380V Brake

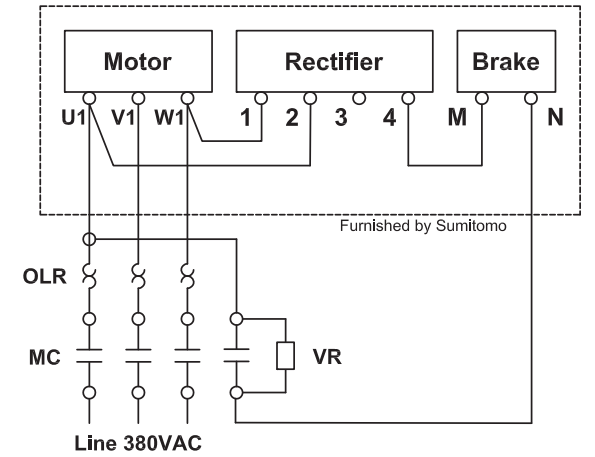

## Models FB-01A1 through FB-15E with Inverter

Normal Brake Action

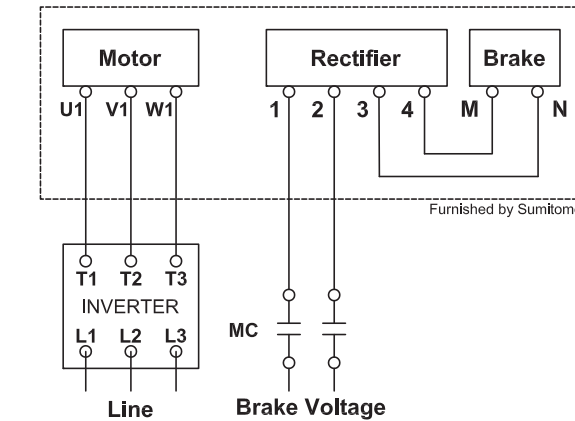

Fast Brake Action

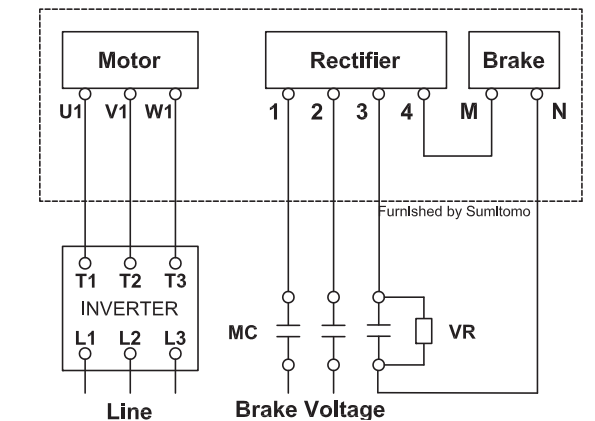

**Key:**  
**MC:** Motor Contactor    **OLR:** Overload or Thermal Relay    **MCB:** Magnetic Circuit Breaker  
**VR:** Varistor (protective device, refer to Varistor Specification Table)

Table 5.41 Standard CE Motor, Motor/Brake Voltage Table

Motor Power kW x 4P	Brake Model	Motor Voltage	Brake Voltage
0.75	FB-1E	220/380V, 50Hz	220V, 50Hz*
1.1	FB-2E		
1.5	FB-1HE		
2.2	FB-3E		
3.0	FB-4E		
3.7	FB-5E	380V, 50Hz	380V, 50Hz
5.5	FB-8E		
7.5	FB-10E		
11	FB-15E		

\*Optional 380V 50Hz Brake Available

Table 5.42 Varistor Specification Table

Operating Voltage		190-230V	380-460V
Varistor Rated Voltage		AC260-300V	AC510V
Varistor Voltage		430-470V	820V
Rated Watt	FB-01A1, 02A1, 05A1	Over 0.4W	Over 0.4W
	FB-1E, 1D	Over 0.6W	Over 0.6W
	FB-1HE, 2E, 2D, 3E	Over 1.5W	Over 1.5W
	FB-5E, 2E, 2D, 3E	Over 1.5W	Over 1.5W

Technical Information

Technical Information

## Wiring for Brake Models FB-20 / FB-30 - EP.NA Motor and IE3 CE Motor

FB-20 and FB-30 Brake Wiring, 480VAC or less

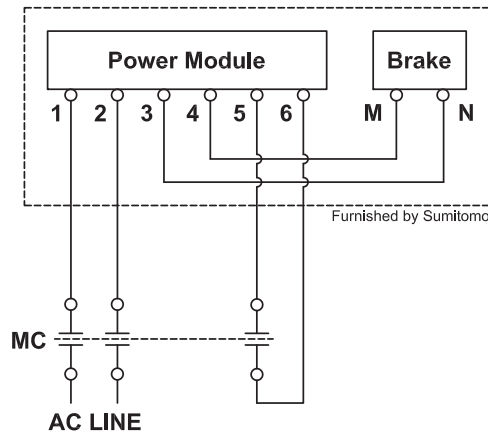

FB-20 and FB-30 Brake Wiring, 575VAC

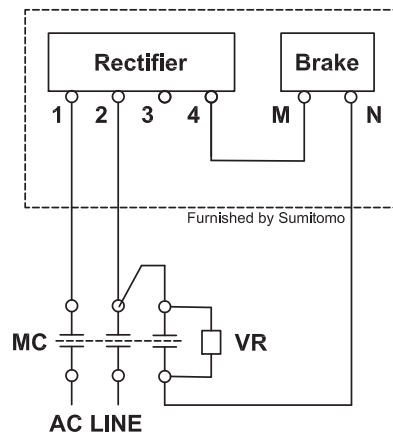

**Key:**  
**MC:** Motor Contactor  
**VR:** Varistor (protective device, refer to Varistor Specification Table)  
 Varistor Rated Voltage - AC604V  
 Varistor Rated Watts - Over 1.5W

## Brake Rectifiers and Brake Power Modules

Table 5.43a Brake Rectifiers for Fractional Motors

Brake Type	Motor Power HP x P	230V/460V Rectifier		575V Rectifier	
		Model Number	Part Number	Model Number	Part Number
FB-01A1	1/8 X 4	25FW-4FB3	EY477WW-01	10F-6FB3	EY498WW-01
FB-02A1	1/4 - 1/3 X 4				
FB-05A1	1/2 X 4				
FB-1D	3/4 X 4				
FB-2D	3/4 X 4				

Table 5.43b Brake Rectifiers for Fractional Motors

Brake Type	Motor Power kW x P	220V Rectifier	
		Model Number	Part Number
FB-01A1	0.1 X 4	10F-2FB2	MP983WW-01
FB-02A1	0.2 - 0.25 X 4		
FB-05A1	0.37 X 4		
FB-1D	0.55 X 4		

Table 5.43c Brake Rectifiers for EP.NA Motors up to 15 HP

Brake Type	Motor Power HP x P	230V/460V Rectifier		575V Rectifier	
		Model Number	Part Number	Model Number	Part Number
FB-1E	1 x 4	25FW-4FB3	EY477WW-01	10F-6FB3	EY498WW-01
FB-1HE	1.5 x 4				
FB-2E	2 x 4				
FB-3E	3 x 4				
FB-5E	5 x 4				
FB-8E	7.5 x 4				
FB-10E	10 x 4				
FB-15E	15 x 4				

Table 5.43d Brake Rectifiers for IE3 CE Motors up to 11 kW

Brake Type	Motor Power kW x P	220V Rectifier		380V Rectifier	
		Model Number	Part Number	Model Number	Part Number
FB-1E	0.75 x 4	10F-2FB2	MP983WW-01		
FB-1HE	1.1 x 4				
FB-2E	1.5 x 4				
FB-3E	2.2 x 4				
FB-4E	3.0 x 4				
FB-5E	3.7 x 4 4.0 x 4				
FB-8E	5.5 x 4			05F-4FB2	MP985WW-01
FB-10E	7.5 x 4				
FB-15E	11 x 4			15F-4FB1	EW397WW-01

Table 5.44 Brake Rectifiers and Power Modules for EP.NA Motors and IE3 CE Motors (20-40 HP)(15-30 kW)

Brake Type	Motor (HP x P)	Motor Power (kW x P)	170 ~ 300VAC Module		380 ~ 480VAC Module	
			Model Number	Part Number	Model Number	Part Number
FB-20	20 x 4	15 x 4	13SR-2	EY570WW-01	10SR-4	MQ003WW-01
FB-30	25 x 4	18.5 x 4				
	30 x 4	22 x 4				
	40 x 4	30 x 4				

\*optional 380V 50Hz Brake Available

# Warranty

Company warrants that (i) all new equipment and parts (collectively, "Equipment") sold by Company will conform to printed drawings and specification sheets issued by Company and (ii) are free of defects in material and workmanship for the time period shown in Table 1. The warranty period commences on the date of shipment of the Equipment by Company.

If, within the warranty period, Company receives from Buyer written notice of any alleged defect in any of the Equipment and, if the Equipment is found by Company not to conform with these warranties (after Buyer has provided Company a reasonable opportunity to perform any appropriate tests on the allegedly defective Equipment), Company will, at its sole option and expense, either repair or replace the Equipment. In all instances, Company reserves the right to require Buyer to deliver the Equipment for repair or replacement to a designated service center and require Buyer to pay all charges for inbound and outbound transportation and for services of any kind, diagnostic or otherwise, excepting only the direct and actual cost of Equipment repair or replacement. Warranty coverage is limited to parts and labor and does not include travel and other expenses. Buyer applications and use of the Equipment may require installation of safety features. Buyer is responsible for furnishing and installing guards or other safety equipment needed to protect operating personnel, even though such equipment may not be furnished by Company with the Equipment purchased. Equipment supplied, but not manufactured, by Company is warranted only to the extent of the original manufacturer's warranty.

**Table 5.45 - Product Warranty**

Product	Warranty Period (After Shipment)	Components Excluded
Cyclo® Speed Reducers and Gearmotors	2 Years	Normally Wearing Items
Cyclo® Bevel Buddybox Speed Reducers and Gearmotors	2 Years	Normally Wearing Items
Cyclo® Helical Buddybox Speed Reducers and Gearmotors	2 Years	Normally Wearing Items
Fine Cyclo® Speed Reducers	2 Years	Normally Wearing Items
Beier® Variator Mechanical Adjustable Speed Reducers	2 Years	Normally Wearing Items
Hyponic® Speed Reducers and Gearmotors	2 Years	Normally Wearing Items
Hedcon® Double Enveloping Worm Gear Speed Reducers	2 Years	Normally Wearing Items
Helical Shaft Mount Speed Reducers	2 Years	Normally Wearing Items
Rhytax®	2 Years	Normally Wearing Items
IB Series Servo Gearheads	1 Year	Normally Wearing Items
Astero Gearmotors	1 Year	Normally Wearing Items
Variable Frequency Inverters	1 Year	---
Paramax® Speed Reducers	2 Years	Normally Wearing Items
Compower Planetary Speed Reducers	1 Year	Normally Wearing Items
Hansen UniMiner	2 Years	Normally Wearing Items
Hansen P4	2 Years	Normally Wearing Items
Parts	1 Year	---
Repairs	1 Year	Normally Wearing Items

Cyclo® HBB  
 Technical Information