



### Sumitomo Drive Technologies

A global power transmission solutions provider, with facilities strategically located throughout the world, providing comprehensive products and services in your region.



- ★ MANUFACTURING HUB
- ASSEMBLY & SERVICE
- SERVICE
- ▲ REGIONAL SALES OFFICE

**Configurator**  
Configure our products to *your* needs.

Sumitomo Machinery Corporation of America

[www.SumitomoDrive.com](http://www.SumitomoDrive.com)

For worldwide locations, please visit [www.sumitomodrive.com/worldwide](http://www.sumitomodrive.com/worldwide)  
Contact your local representative at [www.sumitomodrive.com/representative](http://www.sumitomodrive.com/representative)  
Tel: 1-800-SM-CYCLO (762-9256) 07.001.51.008 Paramax Brochure 2024

### PX PARAMAX® 9000



- Immersion Heater
- Creep Drive
- Anti-Dust Breather



**ACCESSORIES**

- Solid Shaft
- Shrink Disc
- Keyed Hollow Bore



**OUTPUTS**

**AVAILABLE SPLIT HOUSING**

Offered in large frame sizes allowing easy maintenance. Large inspection port provides a window for gear inspection. Standard gray cast iron with ductile and fabricated steel options

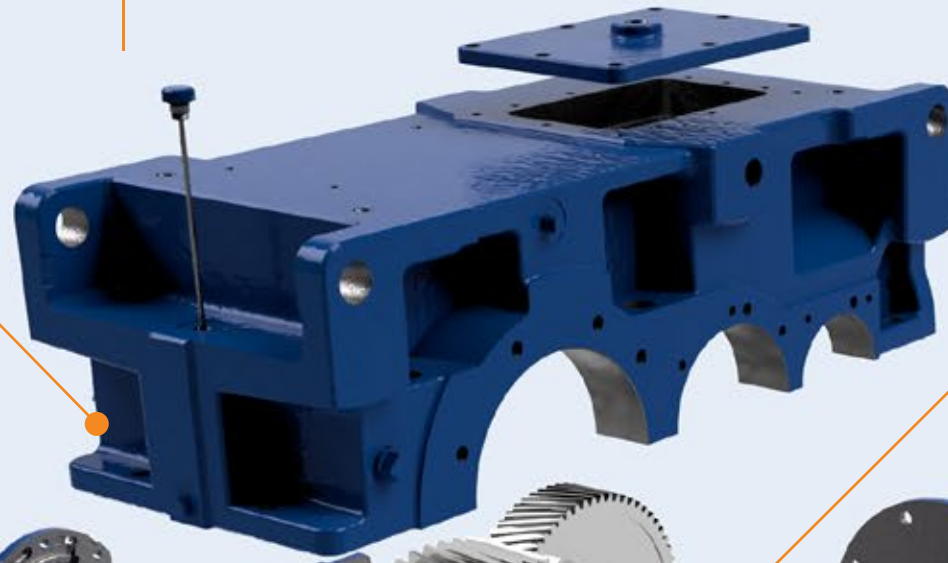

**CASE CARBURIZED GEARING**

High precision case carburized gearing with a 25° pressure angle offer a thicker dedendum and higher strength ratings than the typical 20° pressure angle.

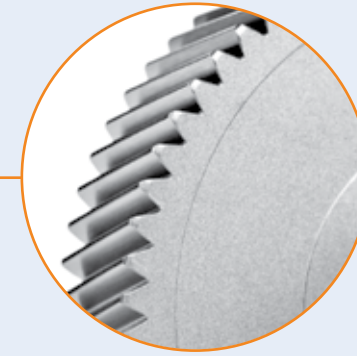

**TACONITE SEAL**

Option features a dual layer oil and grease sealing system



**SLOW SPEED SHAFT**

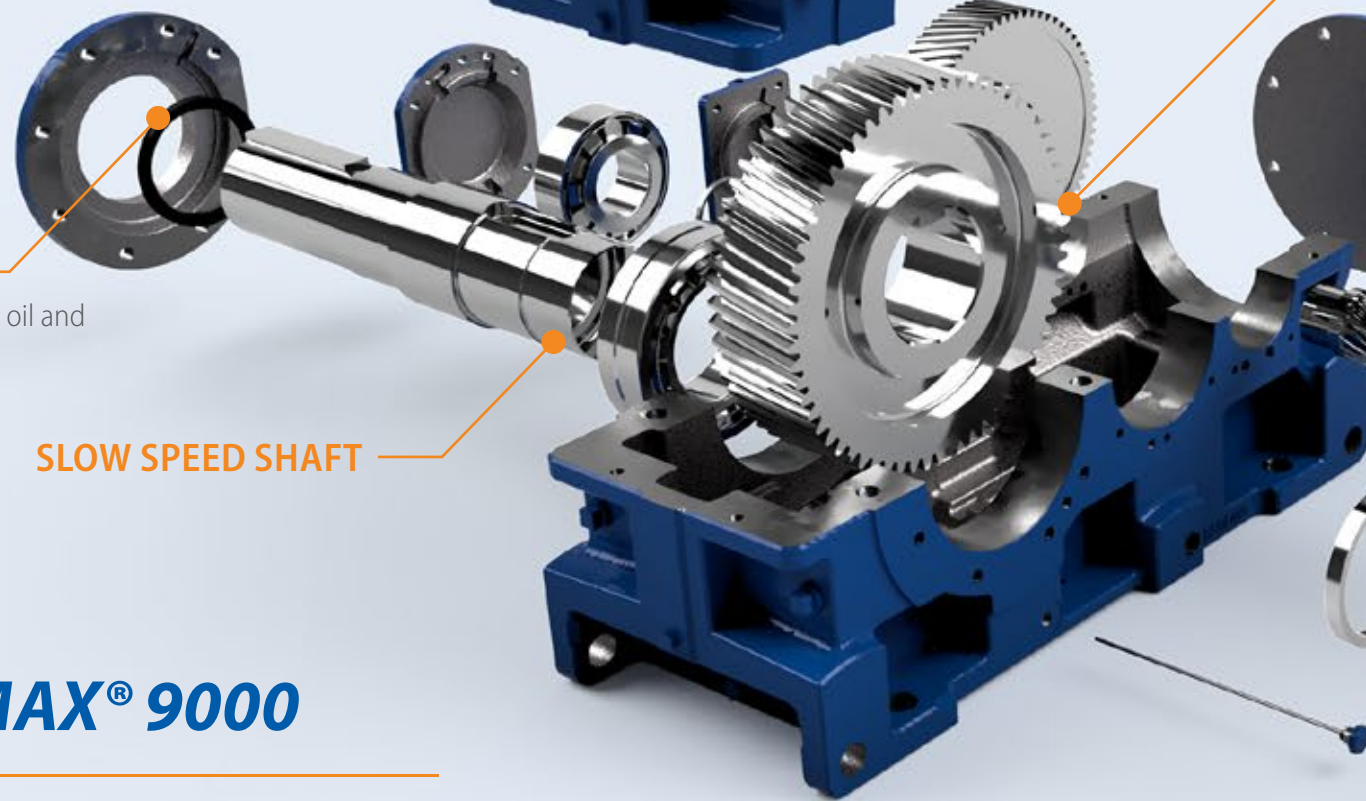

**HIGH TENSILE SHAFT**

Strong shaft material optimized for extended operation in rugged environments



**SPHERICAL ROLLER BEARING**

High capacity bearings increase load capacity without increasing lead-time

**PX PARAMAX® 9000**

**PARALLEL & RIGHT ANGLE LARGE INDUSTRIAL GEARBOXES**

Paramax® parallel and right angle drives are some of the largest and most durable power transmission systems operating in the world. The series features double, triple, quadruple reduction gearboxes, global standardization and availability, and support from our worldwide locations.

Other accessories: Cooling Fan with Split Fan Hood, Resistance Temperature Detector, Coupling Guards & more.

**MOUNTING**



**SPECS**



**HP RATING**  
Up to 5,230 HP  
(3,900 kW)



**DIAMETER**  
5mm to 360mm  
(Hollow & Solid)



**TORQUE**  
Up to 4.9 million lb•in  
(553,626 N•m)



**RATIO RANGE**  
6.3:1 to 500:1  
Standard