

- ★ MANUFACTURING HUB & HEADQUARTERS
- ★ MANUFACTURING HUB
- ASSEMBLY & SERVICE
- SERVICE
- ▲ REGIONAL SALES OFFICE

Sumitomo Drive Technologies

A global power transmission solutions provider. With facilities strategically located throughout the world, providing comprehensive products and services in your region.

Headquarters



4200 Holland Blvd
Chesapeake, VA 23323

email: SMA.CustomerService@shi-g.com
phone: 757-485-3355

Sumitomo Machinery Corporation of America
www.SumitomoDrive.com

For worldwide locations, please visit www.sumitomodrive.com/worldwide
Contact your local representative at www.sumitomodrive.com/representative
Tel: 1-800-SM-CYCLO (762-9256) 01.076.51.002 Steel Brochure 2024

Steel Industry



Sumitomo Drive Technologies

Why choose Sumitomo Drive Technologies for Steel applications?

We offer the toughest drives available to meet the harshest demands.

We know the Steel Industry



STRONG AND ROBUST PRODUCTS

Steel applications and environments are tough, but our gearboxes are tougher. Sumitomo has gearing and power transmission solutions to meet your needs.



WORLD-LEADING SUPPLIER

Our company is one of the world's leading suppliers of drive packages for the steel industry.



LOWER COSTS OF OWNERSHIP

Sumitomo will help keep your operation running effectively and efficiently.

The Right Gearbox for the Right Job

We are interested in selling the right gearbox for the application—not just any gearbox in our inventory. **Sumitomo Drive Technologies has the products that perform.** Standard large industrial gearboxes are pre-engineered and manufactured to be assembled from our inventory. Local engineering, manufacturing, and assembly allow us to customize these products to meet your needs.

Our robust gearboxes have various upgrades and performance monitoring products to keep each gearbox in action. By following our preventative maintenance procedures, you ensure your gearbox lives a long life. Plus, your operation is well protected with one of the most extended warranties in the gearbox industry. If your gearbox has an issue, our experienced network of aftermarket experts is always available. We ask the right questions to ensure you have the correct industrial gearbox for your specific application. Customer experience is our top priority, and we want to ensure that our customers can get the modifications or custom options they desire.



C CYCLO® 6000

- Cycloidal Technology
- Optimal Efficiency
- 500% Shock Overload Resistance, 2-1/2 Times Greater than involute gearing



B4 CYCLO® BBB 4

- Taper-Grip® Bushing
- Standard Ductile Iron Housing
- All-Steel Internal Components



P PARAMAX® 9000

- AGMA Class 11+ Gearing
- Ductile/Steel Housing Options
- 25° Pressure Angle Gear Teeth



HB CYCLO® HBB

- Cycloidal Technology
- Double Output Seals
- No Thermal Limitations



CO COMPOWER

- Compact, Torque Dense Planetary Design
- High Shock Load 27° Pressure Angle
- Multiple Mounting Methods



INVERTERS P2

- Integral Brake Transistor
- 98% Typical Efficiency
- User-Friendly Interface

Old, obsolete gearboxes are high maintenance and difficult to replace.

Steel mills are a tough, high-impact, high shock-load environment.

The Challenge:

Replacing extinct gearing without making modifications to existing equipment.

Sumitomo Problem Solvers:

With Sumitomo powering your steel mill operation, you can expect reduced operation costs, increased efficiency, and a known brand to help you with your gearbox needs.

The Answer: Cyclo Steel Foot

- Dimensional drop-in with custom fabricated Steel Foot
- No modifications needed for existing equipment
- Increase service factor
- Cyclo technology with 500% shock load capabilities
- Internal components manufactured from hardened, vacuum-degassed, 52100 bearing grade steel for minimal vibration, low noise, low backlash and extended operational life



*Steel foot highlighted in green

The Challenge:

Keep your gearboxes running reliably and efficiently in a demanding environment.

Sumitomo Problem Solvers:

Our gearboxes can be manufactured in many different ratios and various output shaft arrangements. Our Cyclo Mill Duty option package offers the most robust options.

The Answer: Cyclo Mill Duty

- High-strength ductile iron housing
 - 200% stronger than standard cast iron housings
- Rugged high capacity spherical roller bearings
 - Increased overhung load capacity
- Severe duty breather
 - Keeps out airborne contaminants
- Two dual lip seals
 - Minimize lubrication leaks and extend service life
- Steel shoulder bolts
 - Strengthens impact and overload protection



Crane



P B4

Ladle Turret



CO P

Roll Tables



C HB

Reheat Furnace



C B4 HB

Mill/Rolling Stand

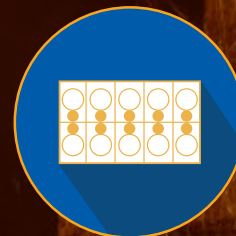

P CO

Coiler



C P

Bridle



P

Mold Oscillator/
Adjuster

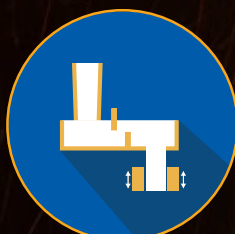

P C B4

Conveyor



C B4 HB

Leveler



C P

Transfer/Ladle Car



P B4 HB

Furnace Door



C B4

Torch Table



C B4 HB

Cooling Table



P C B4

Billet/Slab Pusher



P

Retro-Fit units with transition bases allow us to match your existing footprint.

Custom drop-in units made to match existing unit's critical dimensions.

Retro-Fits and Drop-Ins

Whatever your requirements, we have a solution for you. Sumitomo offers customized bases that allow our units to match the footprint of an array of existing applications and drop-in gear drives to upgrade and replace competitor units.

Our engineers can replace your unit with minimum impact with a wide range of options while delivering a premier product with performance and reliability.

Retro-Fit

Match existing footprint

A custom transition base will position the new low-speed shaft in the EXACT same position as the original low-speed shaft. Our retrofits provide an excellent balance between the cost savings of a standard gearbox and the benefits of minimal on-site modifications.

Typically, only relocating the motor mount is required for this option. We offer motor mounting options to help minimize the impact of relocating the motor mount, such as a flanged motor adapter for C-face or D-flange motors.

Options might include a special low-speed shaft diameter or length and motor lantern.

The red circles in the diagram represent the existing bolt pattern of a customer's unit. The transition base is fabricated to match the height, ensuring alignment of the low-speed shaft to the machine shaft.

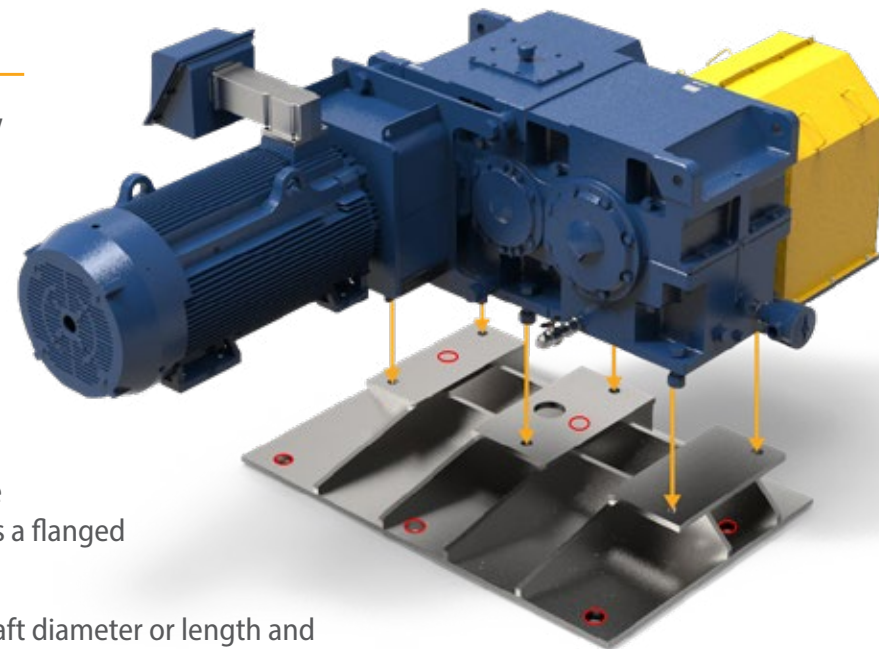

Drop-In

Match existing unit's critical dimensions

With downtime being such a critical factor in your operation, let us install one of our custom drop-in units.

Sumitomo's installation-ready units are explicitly designed to drop into existing applications with no difficulties. Our expert engineers understand that on-site modification or re-engineering your system is not always an option.

Our stress-free units can have your application back up and running in no time. We offer fabricated steel housings, custom baseplates, custom gearing, and shafting, and more!

This product will literally drop into place - same footprint, same shaft positions!

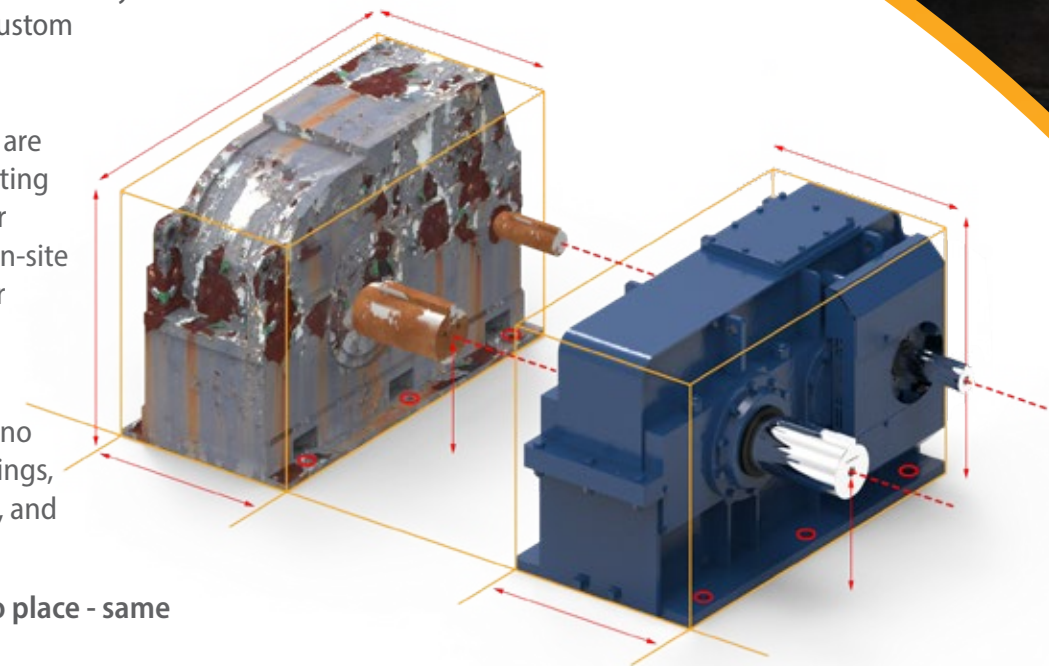

Specialty Units

For non-standard gearing and custom ratios, we offer special customized units to fit in any application. Our team of engineers will make sure all of your custom gearbox needs are met, from custom paint to intricate gearbox lubrication systems.

We have exceptional engineering and factory capabilities to support you on your gearbox needs.



OPTIDRIVE E3

GENERAL PURPOSE DRIVE

Compact, robust, and reliable general-purpose drive.

Focused on ease of use, Optidrive E3 provides unrivaled simplicity of installation, connection, and commissioning, allowing the user to benefit from precise motor control and energy savings within minutes.

Available in IP66/NEMA 4X outdoor rating with tough polycarbonate plastics specifically chosen to withstand degradation by ultraviolet (UV), greases, oils, and acids. Also, robust enough not to be brittle at -20°C (-4°F).

- 150% Overload for 60 secs
- 175% Overload for 2.5 secs
- 98% Typical Efficiency

Compliant with international standards.



ENCLOSURES

FAST CONNECTION

5mm rising clamp terminals with captive screws.

KEYHOLE MOUNTS

QUICK REFERENCE

Integrated help card.

OPTISTICK SMART

Rapid Commissioning Tool that allows copying, backup, and the restoring of drive parameters.



DUAL ANALOG INPUTS



INTEGRATED DISPLAY

LED or multi-language text display.

INTEGRATED CABLE MANAGEMENT

PLUGGABLE CONTROL TERMINALS

FANS

High quality long-life fans.

OPTIDRIVE P2

HIGH PERFORMANCE DRIVE

A high-performance variable frequency drive for standard induction and permanent magnet motors.

A user-friendly interface and high performance make it perfect for tackling the most demanding applications smoothly.

Extensive I/O and communications interface capabilities ensure the drive can be integrated quickly and efficiently into a wide variety of control systems.

Dedicated Hoist Mode Operation with motor holding brake control makes it perfect for marine and elevator applications.

SPECS



HP RATING
Up to 350 HP
(250 kW)



POWER OPTIONS
Single-Phase: 200-240V
3-Phase: 200-600V



TORQUE
Up to 200%
(From Zero Speed)

- 200% Overload for 4 seconds

- 98% Typical Efficiency

- Integral Brake Transistor

*We take asset management seriously,
because we know you do.*

*Avoid catastrophic failure, minimize risk
and increase machine uptime.*

System Management And Reliability Technology (SMART)

SMART is a range of products and reducer options that were developed to help end users in their reliability and asset management initiatives within their plant's daily operations.



Reliability Monitoring

These reducer option packages will help in the consistent collection of data. For Vibration analysis, as well as oil condition and cleanliness testing

Large Industrial Gearboxes

OPTIONS*

Opt 1: Machined Accelerometer Mounting Pads Only

Opt 2: Opt 1 + Accelerometers Wired to Junction Box

Opt 3: Opt 2 + Outputs to Customer PLC or DCS

YOU THINK!



Condition Monitoring

Fully customizable systems provide real time condition data of any piece of rotating equipment. Providing an accurate condition signal without the need for further analysis

All Gearboxes

OPTIONS **

Vibration + Temperature Input

Vibration + Oil Level Input

Vibration + Oil Condition

WE THINK!

CycloSMART® Benefits

- **Safe**
Monitor assets from the safety of your desk via networked connections
- **Predictive**
Machine diagnostics for early warning and detection to avoid failure
- **Optimization**
Customizable systems to meet many different application needs
- **Expandable**
Multi-reducer monitoring
- **Reliable**
Schedule machine downtime to avoid lost production
- **Cost-Effective**
Lower overall ownership cost

the **CHECK** 
ENGINE LIGHT for
SPEED REDUCERS

* All DriveSMART® options include: Oil sampling pitot tube, and Oil Breather package that incorporates oil fill and drain ports.

** All CycloSMART® systems are customizable with many different options for data monitoring. Examples are shown.

Learn more at: SumitomoDrive.com/CycloSmart



Our team of factory-trained technicians has centuries worth of experience.

Connecting you to the service you need.

Experts in Service

Global Support, Local Service

Our personnel are the industry's most versed gearbox problem solvers. We provide both standard and tailored services, for maximum gearbox life.



With a vast network of engineers and gearing experts, there is no problem we can't handle.

In addition to our extensive network, LUFTEX Gears Manufacturing and Services provide unmatched capabilities and expertise in the area of custom gearbox repair and service. With a **60-ton crane capacity and 41 ft hook height, no gearbox is too big for us to handle.**

Whether custom gear manufacturing or on-site gearbox repair, let our team at LUFTEX keep your operation running.

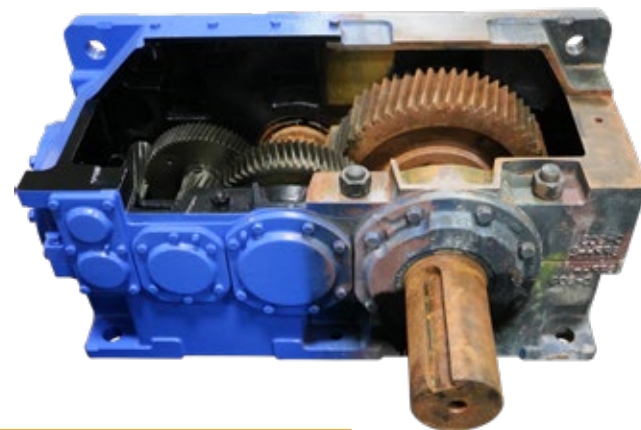

Repairs

Scheduled & Emergency Repair

Repair services for all your related gearbox needs and 24-72 hour turnaround to the original factory specifications and warranty using Sumitomo-manufactured parts.

Extended warranty programs are available upon request.

Root Cause Investigation

Product Support

We'll apply a wide range of approaches, tools, and techniques to uncover the causes of your problems.

Field Services

For Your Convenience

Most of the services offered and customized training can be performed on location.

Custom Solutions

Our gearing engineers can design upgrade options for existing units to increase performance or design complete custom drop-in replacement units that fit into an existing footprint and envelope.

On-Site Solutions

Our team of experienced technicians and engineers can travel to your location to complete your requested repairs and maintenance. These solutions can minimize downtime and get your operation back up and running quickly.

Flexible Solutions for Your Business Needs

SERVICE SOLUTIONS

- Engineering Design and Analysis
- Reverse Engineering of Customer Components
- Design Upgrade Recommendations
- Disassembly and Evaluation of Gear Units
- NDT Inspections
- Manufacturing of Gear Components
- Full-Service Machine Shop
- On-Site Technical Support for Customer Repairs
- Field Service Rebuilds and Repairs
- Commissioning and Start-Up Services
- Root Cause Investigations
- Condition Monitoring

Repair and Rebuild Solutions

Scheduled or emergency repairs can be completed on time and within budget by our Aftermarket team. Utilizing OEM parts and in-house machining and manufacturing capabilities allows us to meet your needs for a quality and timely repair.



Our factory capabilities support all of your gearbox needs.

The most reliable and highest quality products backed by a 400 year heritage.

Why Sumitomo?

Our 400 Year Heritage

The history of the Sumitomo Group started more than 400 years ago when Masatomo Sumitomo opened a book and pharmacy store in the city of Kyoto, Japan. Today, the Sumitomo Group consists of more than 20 companies who share the Sumitomo Emblem as well as many common values and ideals.

Devoted to Quality

In addition to one of the most comprehensive product lines of any power transmission company, we offer the most reliable and highest quality products available in the industry. Whether it's product development or manufacturing processes, our Quality culture resonates through our entire global network.

Committed to our Employees and the Community

We recognize our employees are our most valuable asset. They are the driving force behind our innovative products, our ability to support our customers, and our commitment to continuous process improvement. We strive to be a valuable member of society and take pride in the contributions we make to our communities across North and South America.

Dedicated to Innovative Manufacturing

With more than a century of expertise in manufacturing, our global capabilities are unmatched in the industry. We have manufacturing and assembly facilities on every continent and continue to make investments in our manufacturing technologies to maintain our position as a leader in innovation.

Centers of Excellence

Our Centers of Excellence offer customers a nationwide support network. From inventory distribution to manufacturing to assembly, we have the team to ensure high quality, responsiveness, on-time delivery, and quick lead times.



Chesapeake, VA

Manufacturing, Support, Inventory, and Training

Our Western Hemisphere headquarters has 360,000 sq ft of manufacturing space, and cutting-edge technology. Centralized inventory distribution with a Foreign trade zone (FTZ), focused on inventory optimization, motor assembly, and hands-on training at our Power Institute.



Verona, VA

Industrial Gearbox Production

This purpose-built facility is specifically designed to handle the assembly of our large industrial gearboxes.



Lufkin, TX

Manufacturing and Services

This 32,000 sq ft facility handles gear manufacturing, gearbox repairs, and reverse engineering.



Glendale Heights, IL

Gearmotor Assembly and Support

Houses our state-of-the-art paint system for our SHIELD360® packages for Cyclo®, BuddyBox®, and Hyponic®.