

Sumitomo Drive Technologies

Sumitomo Machinery Corporation of America
Headquarters & Manufacturing
 4200 Holland Boulevard, Chesapeake, VA 23323



Sumitomo Machinery Corp. of America
 Chesapeake, VA
 Glendale Heights, IL
 Verona, VA

Phone: +1.757.485.3355
 +1.630.752.0200
 +1.540.213.2442
 Fax: +1.757.485.7490
 +1.630.752.0208
 +1.540.213.2222

SM Cyclo de Mexico, S.A. de C.V.
 Monterrey
 Guadalajara
 Ciudad de México

+52.81.8144.5130
 +52.33.3675.4323
 +52.55.2282.8700
 +52.81.8144.5130 ext. 3109
 +52.33.3675.4418
 +52.55.2282.8700

SM Cyclo of Canada, Ltd.
 Toronto, ON
 Vancouver, BC

+1.905.469.1050
 +1.604.525.5403
 +1.905.469.1055
 +1.604.525.0879

SM Cyclo Colombia, S.A.S.
 Bogotá

+57.1.300.0673
 +57.1.300.0673 ext. 105

Sumitomo Indústrias Pesadas do Brasil Ltda.
 São Paulo

+55.11.4403.9292
 +55.11.4403.9292

SM Cyclo de Chile Ltda.
 Santiago
 Antofagasta
 Concepción

+56.2.2892.7000
 +56.5.5256.1611
 +56.41.246.9806
 +56.2.2892.7001
 +56.5.5256.1616
 +56.41.246.9171

SM Cyclo de Guatemala Ensambladora, Ltda.
 Guatemala

+502.6648.0500
 +502.6648.9171

SM Cyclo de Argentina, SA
 Buenos Aires

+54.3327.45.4095
 +54.3327.45.4099

World Headquarters

Japan
 Sumitomo Heavy Industries, Ltd.
 Power Transmission & Controls Group
 ThinkPark Tower, 1-1, Osaki 2-chome,
 Shinagawa-ku, Tokyo 141-6025 Japan
 Tel: +81-367-37-2511 • Fax: +81-368-66-5160

www.sumitomodrive.com
E-mail: Customer_Service@suminet.com

©2025 Sumitomo Machinery Corporation of America Printed in USA

Sumitomo Drive Technologies

CYCLO® BEVEL BUDDYBOX® H

Sumitomo Drive Technologies



CYCLO®
BEVEL BUDDYBOX® H

Table of Contents

1. General Information

2. Speed Reducers

How to Select	2.2
Configure a Model Number (Nomenclature) . . .	2.4
AGMA Load Classifications.	2.6
Quill & C-Face Selection Tables	2.7
Servo Selection Tables.....	2.8
Dimensions.....	2.14
Quill HZ522 ~ HA635	2.14
C-Face HZ522 ~ HA635.....	2.16
Servo HZ522 ~ HA635	2.18

3. Gearmotors

How to Select	3.2
Configure a Model Number (Nomenclature) . . .	3.4
AGMA Load Classifications.	3.6
Selection Tables.....	3.10
Dimensions	3.16
Frame Sizes HZ522 ~ HA635	3.16

4. Options

5. Technical Information

Exact Ratios.....	5.2
Shaft Dimensions and Rotation.....	5.3
Special Load Guidelines.....	5.4
Construction.....	5.5
Mounting.....	5.6
Accessories	5.7
Lubrication and Paint	5.9
Motor	5.11
Conduit Box Specifications	5.13
Motor Data.....	5.15
Brakemotor Characteristics	5.24
Wiring Diagrams	5.29
Warranty.....	5.34

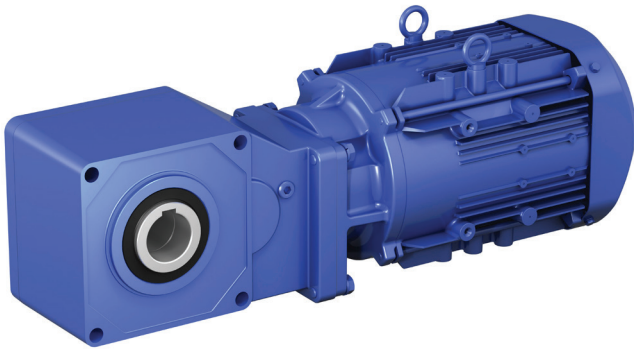

► Grease lubricated design is maintenance free, requires no oil changes and is up to 97% gear efficiency across all ratios

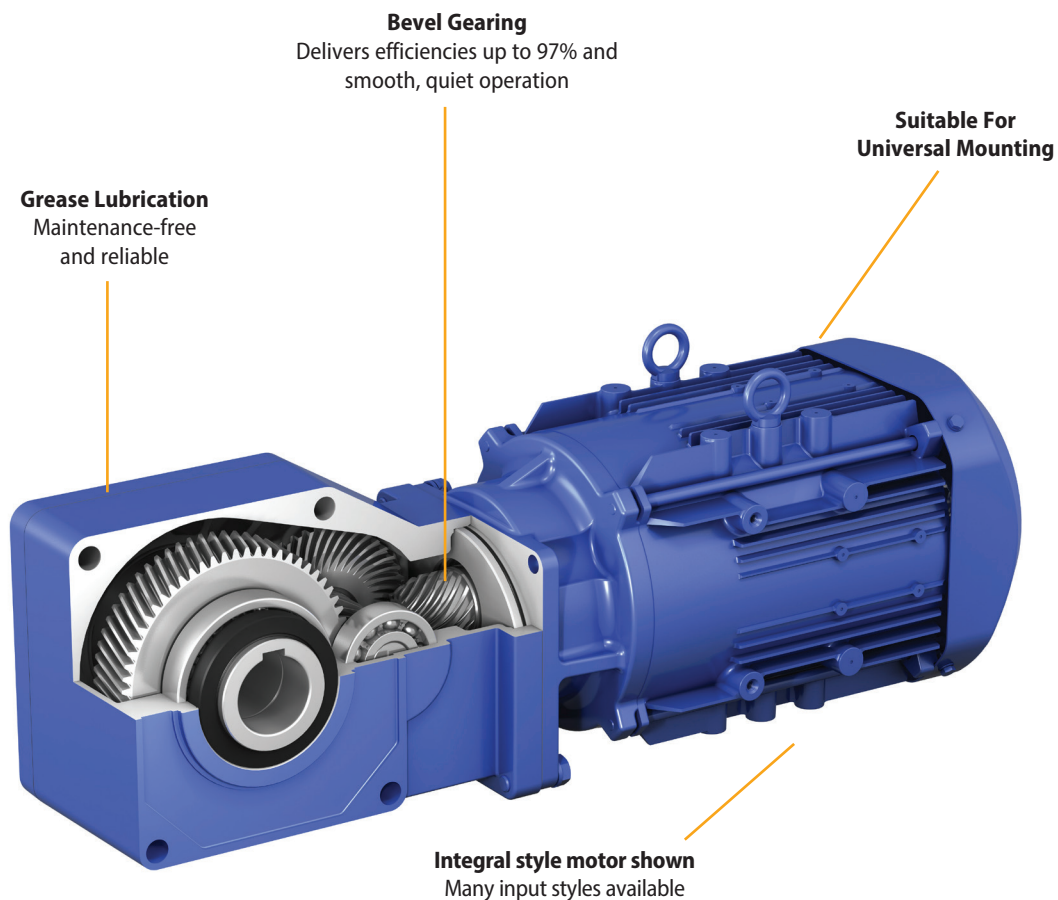

Product Description

The Sumitomo BBB-H® Gearmotor represents 80 years of excellence in the design and manufacture of premium gearing solutions. The highly efficient product features maintenance-free grease lubrication with an unusually compact, modular housing. Options include both C-face quill and coupled designs, integral motors, Easy Grip Bushings, synthetic NSF H-1 food-grade lubricant and stainless steel output shafting. Sumitomo's dependable, all-steel bevel gear technology leads the industry in quiet operation and high efficiency. The Bevel BuddyBox® H Series significantly outperforms worm gearing for all ratios.

Features & Benefits

- **Energy savings**, patented bevel gear technology is up to 97% gear efficiency across all ratios and requires no cooling fan
- **Maintenance-free** grease lubrication eliminates oil changes
- **Long lasting**, all-steel bevel gear design transmits power more efficiently for greater torque density in a compact unit
- **Extremely quiet**, smooth operation is ideal for reducing ambient noise levels
- **Extremely compact**, easy to install design features an aluminum, corrosion resistant housing with optional washdown protections
- Simple keyed hollow bore makes retrofits quick and easy
- Readily available with quick delivery
- **Two-Year warranty**
- Optional Easy Grip Bushing system in selected sizes, for maximum flexibility.



General Specifications Summary

Ratios:	5-20
HP:	3 to 15 hp
Maximum Torque:	12,400 in.-lbs.
Electrical:	230/460 VAC (3-Phase)
Housing:	Lightweight, corrosion-resistant aluminum
Mounting:	Keyed Hollow Shaft, Shrink Disc, or Easy Grip Bushing
Input:	Free Shaft, C-Face, or Servo Hollow Quill, C-Face Adapter or Integral Motor

Quiet, Compact and Maintenance-Free

► Transmits torque more efficiently resulting in lower energy costs



Applications

- Bottling & Food Processing
- Commercial Bakery Lines
- Pharmaceutical Machinery
- Automotive Assembly Plants
- Conveyor Lines & Material Handling
- Residential Elevators & Lifts
- Automated Bay & Dock Door Drives
- Dehydrators
- Packaging

Product Range (Standard Motor and Reducer Combinations)

C-Face Quill Reducer Options

Frame Size	Ratio (:1)	Standard Bore* (Inch)	Output Torque at 1750 RPM Input (in-lb)	Available Motor Frames
HZ522	5 ~ 20	1-1/2	5,870	184TC
HZ523	5 ~ 15	1-1/2	6,450	213TC
HZ524	5 ~ 10	1-1/2	6,050	215TC
HA635	5 ~ 20	2	12,400	215TC

C-Face Adaptor Reducer Options

Frame Size	Ratio (:1)	Standard Bore* (Inch)	Output Torque at 1750 RPM Input (in-lb)	Available Motor Frames
HZ522	5 ~ 20	1-1/2	5,870	184TC
HA635		2	12,400	215TC

Shrink Disc and Easy Grip Bushing option: Refer to page 4.4 and 4.5.

Reduction Ratios 5 - 20: Gearmotor Options

• - Premium Efficiency EP motor

HP	Model	Ratio					
		5	7	10	12	15	20
3	HZ522	•	•	•	•	•	•
5	HZ522	•	•	•	•	•	•
	HZ523	•	•	•	•	•	
7.5	HZ523	•	•	•	•	•	
	HZ524	•	•	•			
	HA635	•	•	•	•	•	•
10	HZ524	•	•	•			
	HA635	•	•	•	•	•	•
15	HA635	•	•	•	•	•	•

Product Range Hollow Shaft Type

Selections shaded in blue offer an increased service factor.
Please refer to the gearmotor selection tables for specific unit service factor details.

Nominal Ratio (:1)		5	7	10	12	15	20
Output RPM (1750 rpm Input)		350	250	175	146	117	88
3-Phase Input Power	3HP	HZ522, Bore φ1.50"					
	5HP	HZ522, Bore φ1.50"					
		HZ523, Bore φ1.50"					
	7.5HP	HZ523, Bore φ1.50"					HA635 Bore φ2.00"
		HZ524, Bore φ1.50"		HA635 Bore φ2.0"			
		HA635 Bore φ2.00"					
	10HP	HZ524, Bore φ1.50"		HA635 Bore φ2.00"			
		HA635 Bore φ2.00"					
15HP	HA635 Bore φ2.00"						

FAQs

How do I select a Bevel Buddybox® H speed reducer or gearmotor?

Selection is based on the actual horsepower and/or torque requirements at the output shaft. The Bevel Buddybox® H speed reducer has particularly high efficiencies over a wide range of reduction ratios, which frequently permits the use of reduced input power requirements (smaller HP or kW motor) without sacrificing output shaft torque. The selection procedures in this catalog will guide you in choosing the most efficient reducer for your application.

What information do I need to get started in the selection process?

To select the proper reducer for your application, you will need to know:

- Application: type of driven machine
- Hours of operation per day
- Motor power (HP or kW) and speed (RPM)
- Mounting position
- Environmental conditions
- Ambient temperature range

If there are any special environmental factors or operation requirements, then they must also be noted. This information will be important in determining the Service Factor of your application.

What are Service Factors and how are they used?

In general, reducers are rated for the specific conditions and operating requirements of the application by the use of AGMA-defined Service Factors. The AGMA Load Classifications table on page 2.6 classifies applications by the type of load to help users to apply the correct service factors shown on page 2.3. The Service Factors are used in the product selection process to adjust for the specific conditions and operating requirements of your application.

What do I do if my application has particularly severe operating conditions?

The standard ratings for Bevel Buddybox® H are based on 10-hour daily service under conditions of uniform loads (equivalent to AGMA service factor 1.0). By following the product selection process, you will determine and apply the Service Factors to compensate for the severe operating conditions.

What are the advantages of a shrink disc?

The shrink disc provides for easy mounting and removal to and from the shaft of the driven machine. Because it requires no keyway, the shaft isn't weakened and maximum torque is transmitted.

What kind of torque arm do I specify?

The standard torque arm is shown on page 4.2. The Bevel Buddybox® H gearbox does not ship with a torque arm unless customer specifies.

Can the BBB-H be mounted in any position?

All frame sizes come standard grease lubricated and can be mounted in any position. Food-grade grease and oil lubrication is available upon customer request.

What is Easy Grip Bushing?

Easy Grip Bushing is keyless shaft mounting system and significantly reduce spare requirement by allowing a single unit to use multiple bore size bushings and unique shrink device to greatly reduce risk of fretting corrosion with easy installation process.

Enhanced Performance (EP) Motors FAQs

What efficiency level are these Enhanced Performance (EP) motors?

The EP motor is a NEMA Premium efficiency class, or International Efficiency 3 (IE3) design.

What standards do these motors meet?

All Sumitomo motors are compliant with the Energy Independence and Security Act (EISA), as recently amended by the Department of Energy with a new ruling.

EP Sumitomo motors met the efficiency levels promoted by the Consortium for Energy Efficiency (CEE) and meet the Canadian efficiency levels specified by NRCan.

The IE3 efficiency ratings conform to both the IEC Standard 60034-30:2009 and eco-design directive 2005/32/EC.

Will Sumitomo motors work with inverters?

All current EP motors feature corona resistant magnet wire that extends the life of the insulation and enables the motors to resist the voltage spikes common with IGBT variable frequency drives.

What agency listings apply?

All EP motors in this product line are UL recognized, CSA certified and CE marked.

Can the motor be nameplated to operate at 50 hertz?

The motor can be nameplated and will operate at 50 hertz, but depending on the export destination, it may not meet that country's energy efficiency requirements. For areas requiring IE3 performance at 50 hertz, like Asia and Europe, other 50 hertz specific versions can be provided. Conformance with energy efficiency requirements in destination country is the responsibility of the customer.

Is the selection procedure the same as previous gearmotors?

Similar, the difference is restricted to applications with a large number of across the line starts and stops. Because the EP motors have more inertia and higher inrush current than previous integral motors, a supplemental service factor is applied to these applications using EP motors. The selection procedure for fractional HP units is unchanged.

Are the brakes the same?

The brakes are the same direct acting, fast response types used previously. The brakes are a new larger model that has been redesigned to match the new motor profiles. Because the EP motor inertia is significantly higher, it may be necessary to adjust external trigger points or limit switches. Since the brake assembly shapes are different, old and new kits are not interchangeable.

What is the standard insulation system?

The motors continue with the Class F system, which limits the temperature rise to a Class B rise, where it bounds the allowable temperature rise to 80°C. It utilizes an insulation system capable of handling a 105°C rise to significantly extend insulation life.

Are EP motors interchangeable with old AF-motors?

The new EP motors without brake have the same 10:1 constant torque speed range as the AF-motor. Motors are dimensionally and performance-wise different so VFD re-programming may be required. For EP brakemotor with use on VFDs, the applicable speed range may be limited. Please consult the factory for options for EP brakemotors.

Standard Specifications

	Standard Specifications	Standard Specifications with Built-In Brake
3 Phase Integral EP.NA Motor	Capacity Range	3 through 15 HP (4 pole)
	Power Supply	Motor Power: 230 / 460V, 60 Hz, 3 Phase 575V, 60 Hz, 3 Phase
	Motor Standard	NEMA
	Efficiency	Premium Efficiency (IE3)
	Protection	IP55
	Certification	CE Mark, UL Recognition, CSA Approval
	Conduit Box	Diecast Aluminum, NPT Conduit Thread
3 Phase Integral IE3 CE Motor	Capacity Range	2.2 kW through 11 kW (4 pole)
	Power Supply	Motor Power (2.2 through 4.0 kW) 230 / 400V, 50 Hz, 3 Phase (5.5 through 11.0 kW) 400V, 50 Hz, 3 Phase
	Motor Standard	IEC
	Efficiency	IE3
	Protection	IP55
	Certification	CE Mark
	Conduit Box	Diecast Aluminum, Metric Conduit Thread
3 Phase Integral Motor - Common	Enclosure	Totally Enclosed Fan Cooled (TEFC)
	Motor Type	Asynchronous Induction Motor, Squirrel Cage Rotor
	Frame Material	Diecast Aluminum
	Bearings	Double Shielded, Deep Groove, Ball Bearing, CM Clearance
	Insulation	Class F
	Time Rating	Continuous
	Bevel Buddybox® H	Reduction
Lubrication		Grease lubricated; filled with special high-grade grease prior to shipment.
Seals		Nitrile and Acrylic, Quad-Lips seal design for output shaft.
Material		Casing: aluminum alloy; Gear: chrome-molybdenum steel
Paint Color		Blue, Munsell color number 6.5PB 3.6/8.2
Bearings		Deep groove ball bearings on input and output
Standard Ambient Conditions	Installation Location	Indoor (Minimal dust and humidity)
	Ambient Temperature	14° ~ 104° F (-10° ~ 40° C)
	Ambient Humidity	Under 85%
	Elevation	Under 3300 feet (1000 meters)
	Atmosphere	Well ventilated location, free of corrosive gases, explosive gases, vapors, and dust

Page intentionally left blank.

2

Speed Reducers

Hollow Shaft Type

Speed
Reducers

How to
Select

How to select a Speed Reducer

Step 1: Collect data about your application

Before starting you need to know the:

- Application (e.g. Conveyor, Mixer, etc.)
- Hours of Operation per day
- Motor Horsepower (HP) and Speed (RPM)
- Desired Output Speed
- Mounting Position and Style
- Overhung or Thrust Loads
- Bore Dimensions, inch or metric
- Ambient Conditions

Step 2: Select a Frame Size

2A: Find the Load Classification of your application in the AGMA Load Classification Tables on pages 2.6. If the BBB-H Reducer will be used in a frequent starts and stops application and the motor will be operated across the line, please refer to Method B on page 3.6.

2B: Find the recommended Service Factor using the Recommended Reducer Service Factor Table on the next page. For Recommended Service Factors for Frequent Start/Stop Applications, consult table on page 3.6.

2C: Determine the Selection Horsepower by multiplying the Motor Horsepower by the Service Factor.

2D: Select a Frame size from the Reducer Selection Tables on pages 2.8–2.13 by matching both the Selection Horsepower and Desired Output Speed (RPMs) to a frame size model number.

Step 3: Verify Dimensions

Use the Dimensions information on pages 2.14–2.19 to verify that the selected Frame Size is appropriate.

Step 4: Choose Options

The following options may apply:

- Shrink Disc
- Easy Grip
- Torque Arm Assembly
- Washdown Modification

Refer to Section 4 of this catalog for dimension drawings of selected popular options .

Step 5: Configure a Model Number

Go to page 2.4 to configure a model number.

Note: You will use the information you gather from the procedure on this page to configure a model Number. For additional options, please visit our configurator at: www.sumitomodrive.com/configurator

Recommended Reducer Service Factors

Duration of Service	AGMA Load Classifications		
	Uniform (U)	Moderate Shock (M)	Heavy Shock (H)
1/2 hr. per day (Occasional)	0.50 ^[1]	0.80 ^[1]	1.25
3 hrs. per day (Intermittent)	0.80	1.00	1.50
Up to 10 hrs. per day	1.00	1.25	1.75
24 hrs. per day	1.25	1.50	2.00

Note: [1] Maximum momentary or starting load must not exceed 300% of gear reducer rating (rating meaning service factor of 1.0). Time specified for occasional and intermittent service refers to total operating time per day.

Determine Selection Horsepower (HP)

$$\text{Motor HP} \times \text{Service Factor} = \text{Selection HP}$$

Example: 10 Motor HP X 1.25 Service Factor = 12.5 Selection HP

Select a Frame Size

1 Match your OUTPUT RPM or (RATIO)...

Output RPM	350	250	175	146	117	87.5	Frame Size
Ratio	5	7	10	12	15	20	
Input Power HP (kW)	8.84 6.59	8.28 6.18	8.35 6.23	7.90 5.89	8.92 6.65	8.50 6.34	
Output Torque			2856 323	3303 373	4656 526	5637 637	HZ522
Hollow Shaft OH			1286 5720	1365 6070	1277 5680	1284 5710	

2 ...to your Selection HP...

3 ...to find your FRAME SIZE...

If Overhung Load is present, it must be checked against the capacity of the selection.



For special circumstances affecting Frame Size selection such as:

- Overhung Load
- Shock Loading

Consult Appendix, pages 5.8.

Speed Reducers
How to Select

Speed Reducers
How to Select

Configure a Model Number

Nomenclature

Output Shaft Orientation

Type	Prefix
Universal Direction (Maintenance Free)	N

Mounting Style

Type	Prefix
Shaft Mount (Hollow Shaft)	Y

Input Connection

Input Connection	Prefix
C-Face Adapter with jaw coupling	J
Quill C-Face	X

Modification

	Prefix
Special	S
Standard	

Frame Size

HZ522, HZ523, HZ524, HA635

Required to be added at end of model number when ordering:

- NEMA frame size for C-face adapter with jaw coupling or Quill adapter.
- Bore size must be supplied for output hollow bore units.
- Optional Industry Package SSC code, refer to page 4.6.

Shaft Specifications

Input Shaft	Output Shaft		Suffix
	Hollow	Solid	
Metric (JIS)	Key (Inch)	Key (Inch)	
Metric (DIN)	-	Key (mm)	G
Inch	Key (Inch)	Key (Inch)	Y

Motor Flange Code

(Blank)	for NEMA Flange Motor
5P	for Servo Motor
5T	
5Z	

for Servo Motor

Flange Code	Input Power HP	Input Power kW	LNYX (Input Hollow Shaft)					
			1/5	1/7	1/10	1/12	1/15	1/20
5P	3	2.2	HZ522					
5T	5	3.7	HZ522					
5T	7.5	5.5	HZ523					
5T	10	7.5	HZ524			HA635		
5Z	15	11						

for NEMA Flange Motor

Flange Code	Max Input Power HP	Max Input Power kW	LNYX (Input Hollow Shaft)					
			1/5	1/7	1/10	1/12	1/15	1/20
182TC, 184TC	5	3.7	HZ522					
213TC	7.5	5.5	HZ523					
215TC	10	7.5	HZ524			HA635		

Flange Code	Max Input Power HP	Max Input Power kW	LNYJ (Input Solid Shaft and Adapter)					
			1/5	1/7	1/10	1/12	1/15	1/20
182TC, 184TC	5	3.7	HZ522					
213TC, 215TC	10	7.5	HA635					

Nominal Total Ratio

5	20
7	
10	
12	
15	



BBB-H product code (always "L")
 Modification (Special feature)
 Input connection
 Mounting style
 Output shaft orientation
 Frame size
 Output shaft direction (shafted model only)
 Shaft specification
 Motor Flange Code
 Ratio

Nomenclature Example:

LNYX – HZ522 – 5T – 10

L – BBB-H HZ522 – Frame Size
 N – Universal Mount 5T – Servo Motor Input Flange
 Y – Shaft Mount (Hollow Shaft) 10 – Ratio
 X – Quill C-Face Input

Speed Reducers Nomenclature

Speed Reducers Nomenclature

AGMA Load Classifications

Quill & C- Face Selection Tables

TYPE OF APPLICATION	TYPE OF LOAD
---------------------	--------------

Agitators	
Pure liquids	U
Liquids and solids	M
Variable-density liquids	M
Blowers	
Centrifugal	U
Lobe	M
Vane	U
Brewing and Distilling	
Bottling machinery	U
Brew kettles, cont. duty	U
Cookers, cont. duty	U
Mash tubs, cont. duty	U
Scale hopper, frequent starts	M
Can Filling Machines	U
Cane Knives	M
Car Dumpers	H
Car Pullers	M
Clarifiers	U
Classifiers	M
Clay Working Machinery	
Brick press	H
Briquette machine	H
Clay working machinery	M
Pug mill	M
Compressors	
Centrifugal	U
Lobe	M
Reciprocating, multi-cylinder	M
Reciprocating, single-cylinder	H
Conveyors — Uniformly Loaded or Fed	
Apron	U
Assembly	U
Belt	U
Bucket	U
Chain	U
Flight	U
Oven	U
Screw	U
Conveyors — Heavy Duty, Not Uniformly Fed	
Apron	M
Assembly	M
Belt	M
Bucket	M
Chain	M
Flight	M
Live roll oven	M
Reciprocating	H
Screw	M
Shaker	H
Cranes (Except for Dry Dock Cranes)	
Main hoists	U
Bridge travel	S
Trolley travel	S
Crusher	
Ore	H
Stone	H
Sugar	M
Dredges	
Cable reels	M
Conveyors	M
Cutter head drives	H
Jig drives	H
Maneuvering winches	M
Pumps	M
Screen drive	H
Stackers	M
Utility winches	M
Dry Dock Cranes	S
Elevators	
Bucket, uniform load	U
Bucket, heavy load	M
Bucket, cont.	U
Centrifugal discharge	U
Escalators	U
Freight	M
Gravity discharge	U
Man lifts	S
Passenger	S
Extruders (Plastics)	
Blow molders	M
Coating	U
Film	U
Pipe	U
Pre-plasticizers	M
Rods	U
Sheet	U
Tubing	U
Fans	
Centrifugal	U
Cooling towers	S
Forced draft	S
Induced draft	M
Large (mine, etc.)	M

TYPE OF APPLICATION	TYPE OF LOAD
---------------------	--------------

Large (industrial)	M
Light (small diameter)	U
Feeders	
Apron	M
Belt	M
Disc	U
Reciprocating	H
Screw	M
Food Industry	
Beet slicer	M
Cereal cooker	U
Dough mixer	M
Meat grinders	M
Generators (Not Welding)	U
Hammer Mills	H
Hoists	
Heavy duty	H
Medium duty	M
Skip	M
Laundry Washers — Reversing	M
Laundry Tumblers	M
Line Shaft	
Drive processing equipment	M
Light	U
Other line shafts	U
Lumber Industry	
Barkers — hydraulic and mechanical	S
Burner conveyor	M
Chain Saw and Drag Saw	H
Chain transfer	H
Craneway transfer	H
De-barking drum	S
Edger feed	H
Gang feed	M
Geen chain	M
Live rolls	H
Log haul-lockline	H
Log turning device	H
Main log conveyor	H
Off bearing rolls	M
Planer feed chains	M
Planer floor chains	M
Planer tilting hoist	M
Re-saw merry-go-round conveyor	M
Roll cases	H
Slab conveyor	H
Small waste-conveyor-belt	U
Small waste-conveyor-chain	M
Sorting table	M
Tipple hoist conveyor	M
Tipple hoist drive	M
Transfer conveyors	M
Transfer rolls	M
Tray drive	M
Trimmer feed	M
Waste conveyor	M
Machine Tools	
Bending roll	M
Notching press, belt driven	S
Plate planer	H
Punch press, gear driven	H
Tapping machine	H
Other machine tools	
Main drives	M
Auxiliary drives	U
Metal Mills	
Draw bench carriage and main drive	M
Forming machines	H
Pinch, dryer and scrubber rolls, reversing	S
Slitters	M
Table conveyors, nonreversing	
Group drives	M
Individual drives	H
Table conveyors, reversing	S
Wire drawing and flattening machine	M
Wire winding machine	M
Mills, Rotary Type	
Ball	M
Cement kilns	M
Dryers and coolers	M
Kilns	M
Pebble	M
Rod, plain and wedge bar	M
Tumbling barrels	H
Mixers	
Concrete mixers, cont.	M
Concrete mixers, intermittent	M
Constant density	U
Variable density	M
Oil Industry	
Chillers	M
Oil well pumps	S
Paraffin filter press	M
Rotary kilns	M

TYPE OF APPLICATION	TYPE OF LOAD
---------------------	--------------

Paper Mills	
Agitators (mixers)	M
Barker, hydraulic	S
Barker, mechanical	S
Barking drum	S
Beater and pulper	M
Bleacher	U
Calenders	M
Calenders, super	H
Converting machine (except cutters, platers)	M
Conveyors	U
Couch	M
Cutters, platers	H
Cylinders	M
Dryers	M
Felt stretcher	M
Felt whipper	H
Jordans	H
Log haul	H
Presses	U
Pulp machine reel	M
Stock chest	M
Suction roll	U
Washers and thickeners	M
Winders	U
Printing Presses	S
Pullers, Barge Haul	H
Pumps	
Centrifugal	U
Proportioning	M
Reciprocating	
Single acting, 3 or more cylinders	M
Double acting, 2 or more cylinders	M
Rotary-gear type	U
Rubber and Plastics Industries	
Crackers	H
Laboratory equipment	M
Mixing mills	H
Refiners	M
Rubber calenders	M
Rubber mill (2 on line)	M
Rubber mill (3 on line)	U
Sheeter	M
Tire building machines	S
Tire and tube press openers	S
Tubers and strainers	M
Warming mills	M
Sand Muller	M
Screens	
Air washing	U
Rotary, stone or gravel	M
Traveling water intake	U
Sewage Disposal Equipment	
Bar screens	U
Chemical fenders	U
Collectors, circuline or straightline	U
Dewatering screens	M
Grit collectors	U
Scum breakers	M
Slow or rapid mixers	M
Sludge collectors	U
Thickeners	M
Vacuum filters	M
Slab Pushers	M
Steering Gear	S
Stokers	U
Sugar Industry	
Cane knives	M
Crushers	M
Mills	H
Textile Industry	
Batchers	M
Calenders	M
Cards	M
Dry cans	M
Dryers	M
Dyeing machinery	M
Knitting machines	S
Looms	M
Mangles	M
Nappers	M
Pads	M
Range drives	S
Slashers	M
Soapers	M
Spinners	M
Tenter frames	M
Washers	M
Winders	M
Windlass	S

U = Uniform Load H = Heavy Shock
M = Moderate Shock S = Contact Sumitomo

Output RPM	350	250	175	146	117	87.5	Frame Size
Ratio	5	7	10	12	15	20	
Input Power HP (kW)	8.84 6.59	8.84 6.59	8.84 6.59	8.84 6.59	8.84 6.59	8.84 6.59	HZ522
Output Torque in-lbs (Nm)	1530 173	2115 239	3027 342	3691 417	4620 522	5859 662	
Hollow Shaft OHL lbs (N)	1095 4870	1212 5390	1286 5720	1365 6070	1277 5680	1284 5710	

Input Power HP (kW)	12.1	12.1	12.1	12.1	12.1		Frame Size	
Input Power HP (kW)	12.1 9.02	12.1 9.02	12.1 9.02	12.1 9.02	12.1 9.02			HZ523
Output Torque in-lbs (Nm)	2133 241	2921 330	4063 459	5045 570	6019 680	-		
Hollow Shaft OHL lbs (N)	890 3960	908 4040	875 3890	955 4250	1030 4580			

Input Power HP (kW)	17.7	17.7	17.7				Frame Size	
Input Power HP (kW)	17.7 13.2	17.7 13.2	17.7 13.2					HZ524
Output Torque in-lbs (Nm)	3009 340	4160 470	6028 681	-	-	-		
Hollow Shaft OHL lbs (N)	758 3370	771 3430	902 4010					

Input Power HP (kW)	29.8	29.8	29.8	24.1	24.1	17.7	Frame Size	
Input Power HP (kW)	29.8 22.2	29.8 22.2	29.8 22.2	24.1 28.0	24.1 28.0	17.7 13.2		HA635
Output Torque in-lbs (Nm)	5116 578	7081 800	10188 1151	10223 1155	12303 1390	12338 1394		
Hollow Shaft OHL lbs (N)	1320 5870	1448 6440	1349 6000	1376 6120	1684 7490	1877 8350		

Speed Reducers
AGMA Tables

Speed Reducers
Selection Tables

Servo Selection Tables

Ratio 5	n1: Input speed [r/min]	Tout: Allowable output torque [in-lbs & N·m]	%ED (10 min. cycle): 90%ED 50%ED 30%ED 70%ED 40%ED
	n2: Output speed [r/min]	Pro: Allowable radial load [lbs & N]	
	P1: Allowable input power [HP & kW]		

Size	n1 [r/min]	50	580	720	870	980	1165	1450	1750	2500	3000	3600
		n2 [r/min]	10	116	144	174	196	233	290	350	500	600
HZ522 Acutal ratio 5.059 (SF=1.78)	P1 [HP]	-	1.99	2.47	2.99	3.36	4.00	4.96	4.96	4.96	4.96	4.96
	P1 [kW]	-	1.49	1.84	2.23	2.51	2.98	3.70	3.70	3.70	3.70	3.70
	Tout [in-lbs]	1040	1040	1040	1040	1040	1040	1036	859	601	501	417
	Tout [N·m]	118	118	118	118	118	118	117	97.0	67.9	56.6	47.2
	Pro [lbs]	1783	1783	1767	1632	1571	1461	1338	1293	1198	1149	1102
	Pro [N]	7930	7930	7860	7260	6990	6500	5950	5750	5330	5110	4900
HZ523 Acutal ratio 5.143 (SF=1.64)	P1 [HP]	-	2.95	3.67	4.43	4.99	5.93	7.37	7.37	7.37	7.37	7.37
	P1 [kW]	-	2.20	2.74	3.31	3.72	4.43	5.50	5.50	5.50	5.50	5.50
	Tout [in-lbs]	1569	1569	1569	1569	1569	1569	1566	1298	908	757	631
	Tout [N·m]	177	177	177	177	177	177	177	147	103	85.5	71.3
	Pro [lbs]	1783	1783	1684	1560	1491	1383	1254	1223	1151	1111	1068
	Pro [N]	7930	7930	7490	6940	6630	6150	5580	5440	5120	4940	4750
HZ524 Acutal ratio 4.969 (SF=1.76)	P1 [HP]	-	4.02	4.99	6.03	6.79	8.08	10.1	10.1	10.1	10.1	10.1
	P1 [kW]	-	3.00	3.72	4.50	5.07	6.02	7.50	7.50	7.50	7.50	7.50
	Tout [in-lbs]	2063	2063	2063	2063	2063	2063	2064	1710	1197	997	831
	Tout [N·m]	233	233	233	233	233	233	233	193	135	113	93.9
	Pro [lbs]	1783	1738	1580	1457	1380	1279	1153	1138	1088	1054	1021
	Pro [N]	7930	7730	7030	6480	6140	5690	5130	5060	4840	4690	4540
HA635 Acutal ratio 5.02 (SF=2.02)	P1 [HP]	-	5.90	7.33	8.85	9.97	11.9	14.7	14.7	14.7	14.7	14.7
	P1 [kW]	-	4.40	5.47	6.60	7.44	8.84	11.0	11.0	11.0	11.0	11.0
	Tout [in-lbs]	3060	3060	3060	3060	3060	3060	3058	2533	1773	1478	1232
	Tout [N·m]	346	346	346	346	346	346	346	286	200	167	139
	Pro [lbs]	2810	2810	2630	2451	2316	2167	1965	1920	1810	1749	1684
	Pro [N]	12500	12500	11700	10900	10300	9640	8740	8540	8050	7780	7490

NOTES: 1. Allowable radial load is the value the loading position of which is 20 mm from output shaft end.
 2. Allowable Max. input speed is 3600r/min.
 3. Each %ED value is at 10 min. cycle
 4. SF shows based on 1750r/min. input.

Servo Selection Tables

Ratio 7	n1: Input speed [r/min]	Tout: Allowable output torque [in-lbs & N·m]	%ED (10 min. cycle): 90%ED 50%ED 30%ED 70%ED 40%ED
	n2: Output speed [r/min]	Pro: Allowable radial load [lbs & N]	
	P1: Allowable input power [HP & kW]		

Size	n1 [r/min]	50	580	720	870	980	1165	1450	1750	2500	3000	3600	
		n2 [r/min]	7.14	82.9	103	124	140	166	207	250	357	429	514
HZ522 Acutal ratio 7 (SF=1.78)	P1 [HP]	-	1.98	2.46	2.97	3.34	3.97	4.96	4.96	4.96	4.96	4.96	
	P1 [kW]	-	1.48	1.83	2.21	2.49	2.96	3.70	3.70	3.70	3.70	3.70	
	Tout [in-lbs]	1430	1430	1430	1430	1430	1430	1430	1434	1188	832	693	578
	Tout [N·m]	162	162	162	162	162	162	162	134	94.0	78.3	65.3	
	Pro [lbs]	1783	1783	1783	1783	1783	1724	1596	1464	1416	1317	1268	1216
	Pro [N]	7930	7930	7930	7930	7930	7670	7100	6510	6300	5860	5640	5410
HZ523 Acutal ratio 7.043 (SF=1.64)	P1 [HP]	-	2.94	3.65	4.42	4.97	5.91	7.37	7.37	7.37	7.37	7.37	
	P1 [kW]	-	2.20	2.73	3.29	3.71	4.41	5.50	5.50	5.50	5.50	5.50	
	Tout [in-lbs]	2141	2141	2141	2141	2141	2141	2141	2145	1777	1244	1037	864
	Tout [N·m]	242	242	242	242	242	242	242	201	141	117	98	
	Pro [lbs]	1783	1783	1783	1686	1607	1488	1344	1320	1250	1210	1167	
	Pro [N]	7930	7930	7930	7500	7150	6620	5980	5870	5560	5380	5190	
HZ524 Acutal ratio 6.868 (SF=1.76)	P1 [HP]	-	4.02	4.99	6.03	6.79	8.08	10.1	10.1	10.1	10.1	10.1	
	P1 [kW]	-	3.00	3.72	4.50	5.07	6.03	7.50	7.50	7.50	7.50	7.50	
	Tout [in-lbs]	2852	2852	2852	2852	2852	2852	2852	2852	2363	1654	1379	1149
	Tout [N·m]	322	322	322	322	322	322	322	322	267	187	156	130
	Pro [lbs]	1783	1783	1684	1547	1461	1349	1210	1203	1167	1138	1106	
	Pro [N]	7930	7930	7490	6880	6500	6000	5380	5350	5190	5060	4920	
HA635 Acutal ratio 6.949 (SF=2.02)	P1 [HP]	-	5.89	7.32	8.84	9.96	11.8	14.7	14.7	14.7	14.7	14.7	
	P1 [kW]	-	4.40	5.46	6.60	7.43	8.83	11.0	11.0	11.0	11.0	11.0	
	Tout [in-lbs]	4230	4230	4230	4230	4230	4230	4230	4232	3507	2455	2046	1705
	Tout [N·m]	478	478	478	478	478	478	478	478	396	277	231	193
	Pro [lbs]	2810	2810	2810	2720	2563	2383	2179	2129	2010	1942	1871	
	Pro [N]	12500	12500	12500	12100	11400	10600	9690	9470	8940	8640	8320	

NOTES: 1. Allowable radial load is the value the loading position of which is 20 mm from output shaft end.
 2. Allowable Max. input speed is 3600r/min.
 3. Each %ED value is at 10 min. cycle
 4. SF shows based on 1750r/min. input.

Speed Reducers Selection Tables

Speed Reducers Selection Tables

Servo Selection Tables

Ratio 10	n1: Input speed [r/min]	Tout: Allowable output torque [in-lbs & N·m]	%ED (10 min. cycle): 90%ED 50%ED 30%ED 70%ED 40%ED
	n2: Output speed [r/min]	Pro: Allowable radial load [lbs & N]	
	P1: Allowable input power [HP & kW]		

Size	n1 [r/min]	50	580	720	870	980	1165	1450	1750	2500	3000	3600
	n2 [r/min]	5	58	72	87	98	117	145	175	250	300	360
HZ522	P1 [HP]	-	1.98	2.46	2.98	3.35	3.98	4.96	4.96	4.96	4.96	4.96
	P1 [kW]	-	1.48	1.84	2.22	2.50	2.97	3.70	3.70	3.70	3.70	3.70
Acutal ratio 10 (SF=1.78)	Tout [in-lbs]	2049	2049	2049	2049	2049	2049	2049	1698	1188	990	825
	Tout [N·m]	232	232	232	232	232	232	232	192	134	112	93.2
	Pro [lbs]	1783	1783	1783	1783	1783	1749	1596	1554	1455	1401	1347
	Pro [N]	7930	7930	7930	7930	7930	7780	7100	6910	6470	6230	5990
HZ523	P1 [HP]	-	2.95	3.66	4.42	4.98	5.92	7.37	7.37	7.37	7.37	7.37
	P1 [kW]	-	2.20	2.73	3.30	3.72	4.42	5.50	5.50	5.50	5.50	5.50
Acutal ratio 9.833 (SF=1.64)	Tout [in-lbs]	2995	2995	2995	2995	2995	2995	2995	2481	1737	1447	1206
	Tout [N·m]	338	338	338	338	338	338	338	280	196	164	136
	Pro [lbs]	1783	1783	1783	1783	1711	1578	1421	1405	1349	1311	1270
	Pro [N]	7930	7930	7930	7930	7610	7020	6320	6250	6000	5830	5650
HZ524	P1 [HP]	-	4.02	4.99	6.03	6.79	8.08	10.1	10.1	10.1	10.1	10.1
	P1 [kW]	-	3.00	3.72	4.50	5.07	6.03	7.5	7.50	7.50	7.50	7.50
	Tout [in-lbs]	4138	4138	4138	4138	4138	4138	4138	3429	2400	2000	1667
	Tout [N·m]	468	468	468	468	468	468	468	387	271	226	188
	Pro [lbs]	1783	1783	1763	1607	1506	1385	1225	1243	1237	1216	1192
Pro [N]	7930	7930	7840	7150	6700	6160	5450	5530	5500	5410	5300	
HA635	P1 [HP]	-	5.90	7.32	8.85	9.97	11.8	14.7	14.7	14.7	14.7	14.7
	P1 [kW]	-	4.40	5.46	6.60	7.43	8.8	11.0	11.0	11.0	11.0	11.0
	Tout [in-lbs]	6091	6091	6091	6091	6091	6091	6091	5047	3533	2944	2453
	Tout [N·m]	688	688	688	688	688	688	688	570	399	333	277
	Pro [lbs]	2810	2810	2810	2810	2743	2540	2293	2271	2174	2113	2046
Pro [N]	12500	12500	12500	12500	12200	11300	10200	10100	9670	9400	9100	

NOTES: 1. Allowable radial load is the value the loading position of which is 20 mm from output shaft end.
 2. Allowable Max. input speed is 3600r/min.
 3. Each %ED value is at 10 min. cycle
 4. SF shows based on 1750r/min. input.

Servo Selection Tables

Ratio 12	n1: Input speed [r/min]	Tout: Allowable output torque [in-lbs & N·m]	%ED (10 min. cycle): 90%ED 50%ED 30%ED 70%ED 40%ED
	n2: Output speed [r/min]	Pro: Allowable radial load [lbs & N]	
	P1: Allowable input power [HP & kW]		

Size	n1 [r/min]	50	580	720	870	980	1165	1450	1750	2500	3000	3600
	n2 [r/min]	4.17	48.3	60	72.5	81.7	97.1	121	146	208	250	300
HZ522	P1 [HP]	-	1.98	2.46	2.98	3.35	3.98	4.96	4.96	4.96	4.96	4.96
	P1 [kW]	-	1.48	1.84	2.22	2.50	2.97	3.70	3.70	3.70	3.70	3.70
Acutal ratio 12.211 (SF=1.78)	Tout [in-lbs]	2502	2502	2502	2502	2502	2502	2502	2073	1451	1209	1008
	Tout [N·m]	283	283	283	283	283	283	283	234	164	137	114
	Pro [lbs]	1783	1783	1783	1783	1783	1783	1670	1630	1533	1482	1425
	Pro [N]	7930	7930	7930	7930	7930	7930	7430	7250	6820	6590	6340
HZ523	P1 [HP]	-	2.95	3.66	4.42	4.98	5.92	7.37	7.37	7.37	7.37	7.37
	P1 [kW]	-	2.20	2.73	3.30	3.72	4.42	5.50	5.50	5.50	5.50	5.50
Acutal ratio 12.2 (SF=1.64)	Tout [in-lbs]	3715	3715	3715	3715	3715	3715	3715	3078	2155	1796	1496
	Tout [N·m]	420	420	420	420	420	420	420	348	244	203	169
	Pro [lbs]	1783	1783	1783	1783	1756	1614	1443	1441	1401	1369	1331
	Pro [N]	7930	7930	7930	7930	7810	7180	6420	6410	6230	6090	5920
HA635	P1 [HP]	-	5.90	7.32	8.85	9.97	11.8	14.7	14.7	14.7	14.7	14.7
	P1 [kW]	-	4.40	5.46	6.60	7.43	8.84	11.0	11.0	11.0	11.0	11.0
	Tout [in-lbs]	7524	7524	7524	7524	7524	7524	7524	6234	4364	3637	3030
	Tout [N·m]	850	850	850	850	850	850	850	704	493	411	342
	Pro [lbs]	2810	2810	2810	2810	2810	2608	2316	2316	2248	2203	2140
Pro [N]	12500	12500	12500	12500	12500	11600	10300	10300	10000	9800	9520	

NOTES: 1. Allowable radial load is the value the loading position of which is 20 mm from output shaft end.
 2. Allowable Max. input speed is 3600r/min.
 3. Each %ED value is at 10 min. cycle
 4. SF shows based on 1750r/min. input.

Servo Selection Tables

Ratio 15	n1: Input speed [r/min]	Tout: Allowable output torque [in-lbs & N·m]	%ED (10 min. cycle): 90%ED 50%ED 30%ED 70%ED 40%ED
	n2: Output speed [r/min]	Pro: Allowable radial load [lbs & N]	
	P1: Allowable input power [HP & kW]		

Size	n1 [r/min]	50	580	720	870	980	1165	1450	1750	2500	3000	3600
	n2 [r/min]	3.33	38.7	48	58	65.3	77.7	96.7	117	167	200	240
HZ522 Acutal ratio 15.25 (SF=1.78)	P1 [HP]	-	1.98	2.46	2.98	3.35	3.98	4.96	4.96	4.96	4.96	4.96
	P1 [kW]	-	1.48	1.84	2.22	2.50	2.97	3.70	3.70	3.70	3.70	3.70
	Tout [in-lbs]	3124	3124	3124	3124	3124	3124	3124	2589	1812	1510	1258
	Tout [N·m]	353	353	353	353	353	353	353	293	205	171	142
	Pro [lbs]	1783	1783	1783	1783	1783	1783	1740	1706	1616	1565	1511
	Pro [N]	7930	7930	7930	7930	7930	7930	7740	7590	7190	6960	6720
HZ523 Acutal ratio 14.538 (SF=1.64)	P1 [HP]	-	2.95	3.66	4.42	4.98	5.92	7.37	7.37	7.37	7.37	7.37
	P1 [kW]	-	2.20	2.73	3.30	3.72	4.42	5.50	5.50	5.50	5.50	5.50
	Tout [in-lbs]	4427	4427	4427	4427	4427	4427	4427	3668	2568	2140	1783
	Tout [N·m]	500	500	500	500	500	500	500	415	290	242	202
	Pro [lbs]	1783	1783	1783	1783	1783	1637	1457	1466	1441	1414	1380
	Pro [N]	7930	7930	7930	7930	7930	7280	6480	6520	6410	6290	6140
HA635 Acutal ratio 14.864 (SF=1.64)	P1 [HP]	-	5.90	7.32	8.85	9.97	11.8	14.7	14.7	14.7	14.7	14.7
	P1 [kW]	-	4.40	5.46	6.60	7.43	8.84	11.0	11.0	11.0	11.0	11.0
	Tout [in-lbs]	9053	9053	9053	9053	9053	9053	9053	7501	5251	4376	3646
	Tout [N·m]	1023	1023	1023	1023	1023	1023	1023	848	593	494	412
	Pro [lbs]	2810	2810	2810	2810	2810	2653	2361	2361	2316	2271	2228
Pro [N]	12500	12500	12500	12500	12500	11800	10500	10500	10300	10100	9910	

NOTES: 1. Allowable radial load is the value the loading position of which is 20 mm from output shaft end.
 2. Allowable Max. input speed is 3600r/min.
 3. Each %ED value is at 10 min. cycle
 4. SF shows based on 1750r/min. input.

Servo Selection Tables

Ratio 20	n1: Input speed [r/min]	Tout: Allowable output torque [in-lbs & N·m]	%ED (10 min. cycle): 90%ED 50%ED 30%ED 70%ED 40%ED
	n2: Output speed [r/min]	Pro: Allowable radial load [lbs & N]	
	P1: Allowable input power [HP & kW]		

Size	n1 [r/min]	50	580	720	870	980	1165	1450	1750	2500	3000	3600
	n2 [r/min]	2.50	29	36	43.5	49	58.3	72.5	87.5	125	150	180
HZ522 Acutal ratio 19.385 (SF=1.78)	P1 [HP]	-	1.98	2.46	2.98	3.35	3.98	4.96	4.96	4.96	4.96	4.96
	P1 [kW]	-	1.48	1.84	2.22	2.50	2.97	3.70	3.70	3.70	3.70	3.70
	Tout [in-lbs]	3971	3971	3971	3971	3971	3971	3971	3291	2303	1920	1600
	Tout [N·m]	449	449	449	449	449	449	449	372	260	217	181
	Pro [lbs]	1783	1783	1783	1783	1783	1783	1783	1763	1693	1646	1594
	Pro [N]	7930	7930	7930	7930	7930	7930	7930	7840	7530	7320	7090
HA635 Acutal ratio 20.382 (SF=1.76)	P1 [HP]	-	4.02	4.99	6.03	6.79	8.1	10.1	10.1	10.1	10.1	10.1
	P1 [kW]	-	3.00	3.72	4.50	5.07	6.03	7.50	7.50	7.50	7.50	7.50
	Tout [in-lbs]	8464	8464	8464	8464	8464	8464	8464	7013	4909	4091	3409
	Tout [N·m]	956	956	956	956	956	956	956	792	555	462	385
	Pro [lbs]	2810	2810	2810	2810	2810	2810	2810	2743	2698	2653	2585
	Pro [N]	12500	12500	12500	12500	12500	12500	12500	12200	12000	11800	11500

NOTES: 1. Allowable radial load is the value the loading position of which is 20 mm from output shaft end.
 2. Allowable Max. input speed is 3600r/min.
 3. Each %ED value is at 10 min. cycle
 4. SF shows based on 1750r/min. input.

Speed Reducers Selection Tables

Speed Reducers Selection Tables

Quill Dimensions

LNYX-HZ522Y - LNYX-HZ524

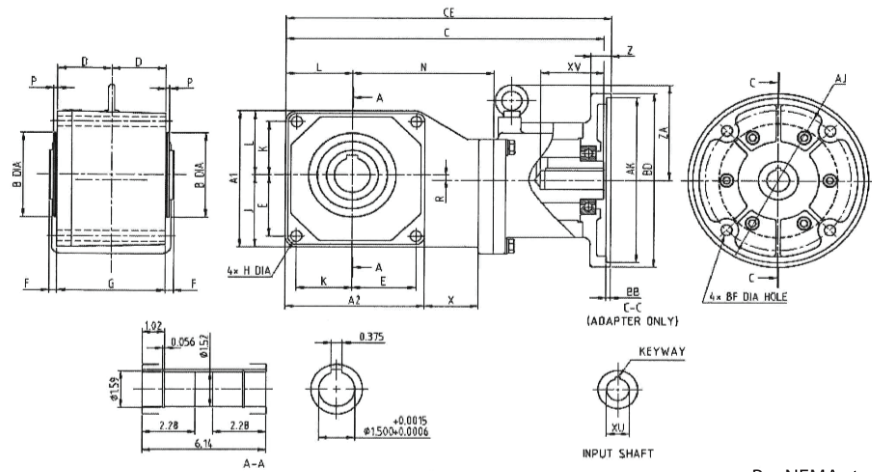

Per NEMA standard

All dimensions are in inches.

Model	A1	A2	B min	B max	D	E	F	G	H	J	K	L	N	P	R	X
LNYX-HZ522Y																
LNYX-HZ523Y	7.01	6.89	4.329	4.331	2.68	3.15	0.39	5.35	0.55	3.70	2.75	3.31	7.01	0.20	0.24	2.68
LNYX-HZ524Y																

Model	Motor Flange Code	CE	C	AK	BD	AJ	BF	Z	BB	ZA	Wt. (lbs.)
LNYX-HZ522Y	182TC, 184TC	16.09	15.76	8.5	8.98	7.25	0.55	1.00	0.2	4.90	61
LNYX-HZ523Y	213TC										
LNYX-HZ524Y	214TC										

Model	Motor Flange Code	XU	XV	KEYWAY
LNYX-HZ522Y	182TC, 184TC	1.13	3.15	1/4 x 1/4 x 1.77
LNYX-HZ523Y	213TC	1.38		5/16 x 5/16 x 2.16
LNYX-HZ524Y	214TC			

Quill Dimensions

LNYX-HA635Y

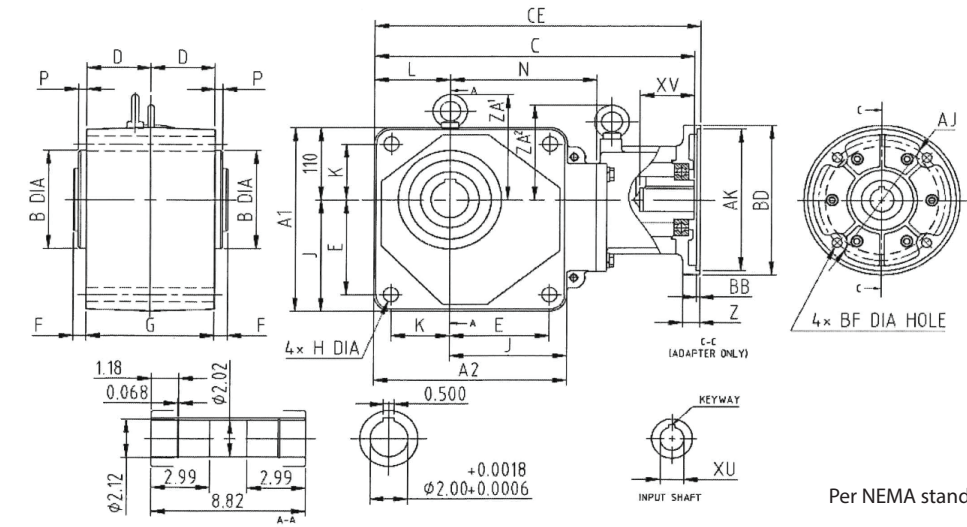

Per NEMA standard

All dimensions are in inches.

Model	A1	A2	B min	B max	D	E	F	G	H	J	K	L	N	P	R	X
LNYX-HA635Y	11.02	11.02	5.904	5.906	3.66	5.71	0.75	7.32	0.87	6.69	3.35	4.33	8.37	0.47	-	6.30

Model	Motor Flange Code	CE	C	AK	BD	AJ	BF	Z	BB	ZA	Wt. (lbs.)
LNYX-HA635Y	213TC, 215TC	18.64	18.31	8.5	8.98	7.25	0.55	1.00	0.22	5.67	121

Model	Motor Flange Code	XU	XV	KEYWAY
LNYX-HA635Y	213TC, 215TC	1.38	3.15	5/16 x 5/16 x 2.16

Speed Reducers Dimensions

Speed Reducers Dimensions

C- Face Dimensions

LNYJ-HZ522Y - LNYJ-HZ524Y

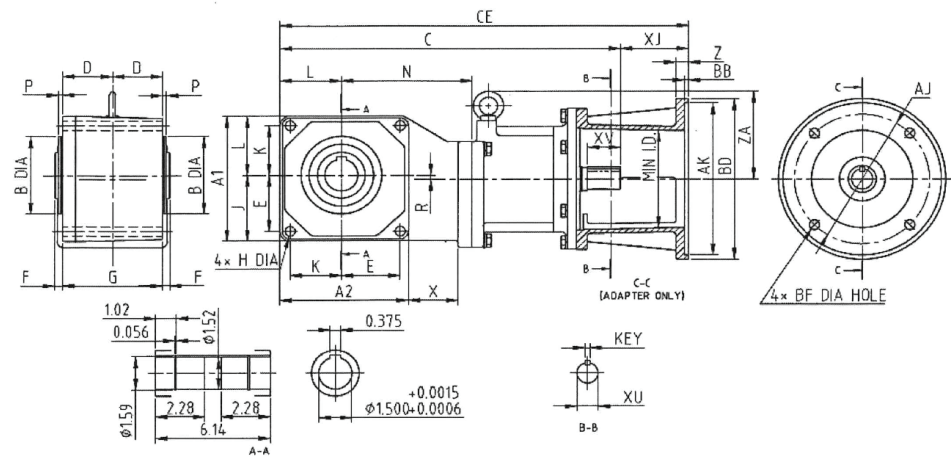

Per NEMA standard

All dimensions are in inches.

Model	A1	A2	B min	B max	D	E	F	G	H	J	K	L	N	P	R	X
LNYJ-HZ522Y																
LNYJ-HZ523Y	7.01	6.89	4.329	4.331	2.68	3.15	0.39	5.35	0.55	3.70	2.76	3.31	7.01	0.20	0.24	2.68
LNYJ-HZ524Y																

Model	Motor Flange Code	CE	C	XJ	AK	BD	AJ	BF	Z	BB	Min. ID	ZA	Wt. (lbs.)
LNYJ-HZ522Y	182TC, 184TC	21.91	18.24	3.67				0.55	0.47				80
LNYJ-HZ523Y	213TC	22.26	18.06	4.20	8.50	8.98	7.25	0.59	0.69	0.22	5.43	4.90	84
LNYJ-HZ524Y	214TC												

Model	Motor Flange Code	XU	XV	KEYWAY
LNYJ-HZ522Y	182TC, 184TC	1.13	1.77	1/4 x 1/4 x 1.77
LNYJ-HZ523Y	213TC			
LNYJ-HZ524Y	214TC			

C- Face Dimensions

LNYJ-HA635Y

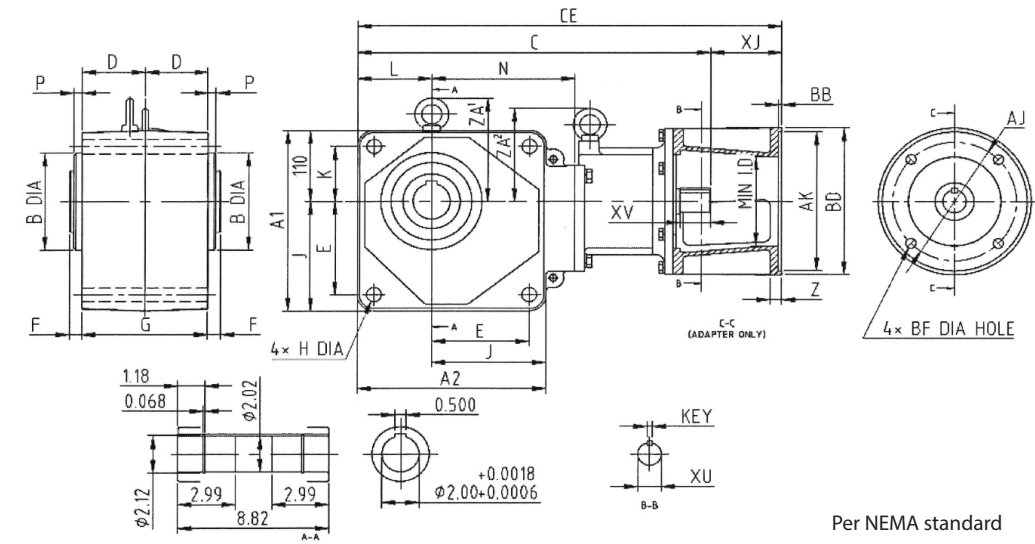

Per NEMA standard

All dimensions are in inches.

Model	A1	A2	B min	B max	D	E	F	G	H	J	K	L	N	P	R	X
LNYJ-HA635Y	11.02	11.02	5.904	5.906	3.66	5.71	0.75	7.32	0.87	6.69	3.35	4.33	8.37	0.47	-	6.30

Model	Motor Flange Code	CE	C	XJ	AK	BD	AJ	BF	Z	Min. ID	ZA	Wt. (lbs.)
LNYJ-HA635Y	213TC, 215TC	24.81	20.60	4.21	8.5	8.98	7.25	0.59	0.69	5.43	5.67	139

Model	Motor Flange Code	XU	XV	KEYWAY
LNYJ-HA635Y	213TC, 215TC	1.38	1.95	5/16 x 5/16 x 2.16

Page intentionally left blank.

Speed Reducers

Selection Tables

3

Gearmotors

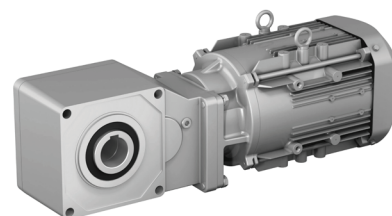

BBB-H

How to
Select

How to Select a Gearmotor

Step 1: Collect data about your application

Before starting you need to know the:

- Application (e.g. Conveyor, Mixer, etc.)
- Hours of Operation per day
- Motor Horsepower (HP) and Speed (RPM)
- Desired Output Speed
- Mounting Position and Style
- Overhung or Thrust Loads
- Bore Dimensions, inch or metric
- Electrical Specifications
- Ambient Conditions

Step 2: Select a Frame Size

2A: Find the Load Classification of your application in the AGMA Load Classification Tables on pages 3.6 and 3.7. If the BBB-H Gearmotor will be used in a frequent starts and stops application and the motor will be operated across the line, please refer to Method B on page 3.6.

2B: Go to the Gearmotor Selection Table that corresponds to the desired Motor HP. Find the Output Speed closest to the desired output speed.

2C: For AGMA Load Classification Method A or C on page 3.6, locate the Service Class in the Gearmotor Selection Tables (starting on page 3.10) for your application and select the Frame Size SELECTION that matches the HP, Output Speed, and Service Class. For Method B, select the Frame Size SELECTION that matches HP, Output speed and Service Factor (NOTE: Service Factor should be equal or exceed to calculated Service Factor on Method B).

Step 3: Verify Dimensions

Use the Dimensions information on pages 3.16–3.19 to verify that the selected Frame Size is appropriate.

Step 4: Choose Options

The following options may apply:

- Shrink Disk
- Easy Grip
- Torque Arm Assembly
- Washdown

Refer to Section 4 of this catalog for dimension drawings of selected popular options.

For additional options, please visit our configurator at:

www.sumitomodrive.com/configurator

Step 5: Configure a Model Number

Go to page 3.4 thru 3.5 to configure a model number.

Note: You will use the information you gather from the procedure on this page to configure a model number.

Selection Tables

Three Phase

3 HP 2.2 kW	Frequency	50 Hz	60 Hz		
	Input Speed	1450 RPM	1750 RPM		
	Number of Poles	4			

Dimensions:	Frame Size	Page	Frame Size	Page
	HZ522	3.16	HZ635	3.18
	HZ523	3.16	HZ635	3.19
	HZ524	3.17		

50Hz					60Hz					Selection				
Output Speed (RPM)	Output Torque		Service Factor ⁽¹⁾	AGMA Class	Solid Shaft Overhung Load		Output Speed (RPM)	Output Torque		Service Factor ⁽¹⁾	AGMA Class	Base		Max Hz ⁽²⁾
	in-lbs	(N·m)	SF		lbs	(N)		in-lbs	(N·m)	SF		Motor Power Code	Frame Size	
287	616	69.6			1338	5950	346	511	57.7			1293	5750	5
207	853	96.4			1464	6510	250	706	79.8			1416	6300	7
145	1221	138			1596	7100	175	1009	114			1554	6910	10
119	1487	168	2.50	III	1670	7430	143	1230	139	3.00	III	1630	7250	12
95.1	1859	210			1740	7740	115	1540	174			1706	7590	15
74.8	2363	267			1783	7930	90.3	1956	221			1763	7840	20

If Overhung Load is present, it must be checked against the capacity of the selection.

How to Select

How to Select

Configure a Model Number

Output Shaft Orientation

Type	Code
Universal Direction (Maintenance Free)	N

Required to be added at end of model number when ordering:

- Motor specifications (230/460 VAC 60 Hz is supplied, unless otherwise specified)
- Optional Industry Package SSC code, refer to page 4.6

Mounting Style

Type	Code
Shaft Mount (Hollow Shaft)	Y

Input Connection

Input Connection	Code
Integral Motor	M
C-Face Adaptor	JM
Hollow Input Shaft	XM

Frame Size

HZ522, HZ523, HZ524, HA635

Modification

Type	Code
Unit built with special modifications including, Shrink Disc	S
No special modifications applied	

Motor Power (applies only to 1750 RPM)

HP	kW	Code
3	(2.2)	3
5	(3.7)	5
7.5	(5.5)	8
10	(7.5)	10
15	(11)	15

AGMA Class

Class	Code
I	A
II	B
III	C

Motor Specification

Specification	Code
Inverter Ready Motor Premium Efficiency (1+HP), IE3	EP

*For Technical Information please contact customer service.
Note: When there are multiple suffices, sequence them alphabetically. Ex.: EPLB

Brake

	Code
With Brake	B
No Brake	-

Nominal Total Ratio

5	20
7	
10	
12	
15	

L N Y M 3 - HZ522 [] [] [] - **EP** - **B** - **10**

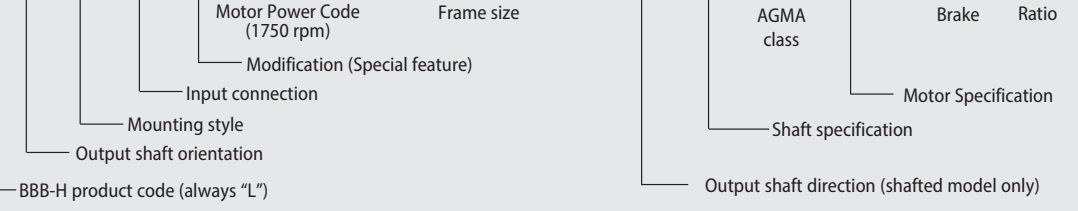

Shaft Specifications

Input Shaft	Output Shaft		Code
	Hollow	Solid	
Metric (JIS)	Key (Inch)	Key (Inch)	
Metric (DIN)	-	Key (mm)	G
Inch	Key (Inch)	Key (Inch)	Y

Nomenclature Example:
LN YM3-HZ522-EP-B-10

L – BBB-H
N – Universal Mount
Y – Shaft Mounted (hollow shaft)
M – Integral Motor
3 – Motor Power Code

HZ522 – Frame Size
EP – Three Phase Motor Premium Efficiency
B – Brake
10 – Ratio

Hyponic®
Nomenclature

Hyponic®
Nomenclature

Constant Torque Speed Ranges: Gearmotors

Page intentionally left blank.

Table 2.8 Turn Down Ratio (CTSR) for Integral Motors in CONSTANT TORQUE Applications Powered by Inverters.

Premium Efficiency Integral HP Motors - 60 Hz			
Motor Power (4 - Pole)	Standard Motor		Oversized Motor
	W/o Brake	With Brake	With and Without Brake
3 HP (2.2 kW)	10:1	4:1	10:1
5 HP (3.7 kW)	10:1	4:1	10:1
7.5 HP (5.5 kW)	10:1	4:1	10:1
10 HP (7.5 kW)	10:1	6:1	10:1
15 HP (11 kW)	10:1	6:1	10:1

BBB-H
CTSR Table

Selection Tables

Three Phase

3 HP 2.2 kW	Frequency	50 Hz	60 Hz
	Input Speed	1450 RPM	1750 RPM
	Number of Poles	4	

<i>Dimensions:</i>	Frame Size	Page	Frame Size	Page
	HZ522	3.16	HA635	3.18
	HZ523	3.16	HA635	3.19
	HZ524	3.17		

50Hz					60Hz					Selection							
Output Speed (RPM)	Output Torque		Service Factor ^[1]	AGMA Class	Overhung Load		Output Speed (RPM)	Output Torque		Service Factor ^[1]	AGMA Class	Overhung Load		Base			Max Hz ^[2]
	in-lbs	(N·m)			lbs	(N)		in-lbs	(N·m)			lbs	(N)	Motor Power Code	Frame Size	Ratio	
287	616	69.6	2.50	III	1338	5950	346	511	57.7	3.00	III	1293	5750	3	HZ522	5	120
207	853	96.4			1464	6510	250	706	79.8			1416	6300			7	
145	1221	138			1596	7100	175	1009	114			1554	6910			10	
119	1487	168			1670	7430	143	1230	139			1630	7250			12	
95.1	1859	210			1740	7740	115	1540	174			1706	7590			15	
74.8	2363	267			1783	7930	90.3	1956	221			1763	7840			20	

Selection Tables

Three-Phase

5 HP 3.7 kW	Frequency	50 Hz	60 Hz
	Input Speed	1450 RPM	1750 RPM
	Number of Poles	4	

<i>Dimensions:</i>	Frame Size	Page	Frame Size	Page
	HZ522	3.16	HA635	3.18
	HZ523	3.16	HA635	3.19
	HZ524	3.17		

50Hz					60Hz					Selection							
Output Speed (RPM)	Output Torque		Service Factor ^[1]	AGMA Class	Overhung Load		Output Speed (RPM)	Output Torque		Service Factor ^[1]	AGMA Class	Overhung Load		Base			Max Hz ^[2]
	in-lbs	(N·m)			lbs	(N)		in-lbs	(N·m)			lbs	(N)	Motor Power Code	Frame Size	Ratio	
287	1035	177	1.49	II	1338	5950	346	858	97.0	1.78	II	1293	5750	5	HZ522	5	120
207	1434	162			1464	6510	250	1186	134			1416	6300			7	
145	2053	232			1596	7100	175	1699	192			1554	6910			10	
119	2504	283			1670	7430	143	2071	234			1630	7250			12	
95.1	3124	353			1740	7740	115	2593	293			1706	7590			15	
74.8	3973	449			1783	7930	90.3	3292	372			1763	7840			20	
282	1053	119			2.02	III	1254	5580	340			873	98.7			2.44	
206	1442	163	1344	5980			248	1195	135	1320	5870	7					
147	2018	228	1421	6320			178	1673	189	1405	6250	10					
119	2496	282	1443	6420			143	2080	235	1441	6410	12					
99.7	2982	337	1457	6480			120	2478	280	1466	6520	15					

Note: [1] Selections with service factor marked with an asterisk (*) should be limited to the identified output torque.
 [2] Maximum allowable input speed is 3600rpm unless otherwise noted.
 Variable Frequency Drive (VFD) notes (see page 3.8 for Constant Torque Speed Ranges)

Note: [1] Selections with service factor marked with an asterisk (*) should be limited to the identified output torque.
 [2] Maximum allowable input speed is 3600rpm unless otherwise noted.
 Variable Frequency Drive (VFD) notes (see page 3.8 for Constant Torque Speed Ranges)
 All 1HP+ motors require EP suffix in model number and can be used with a VFD, unless noted.

Selection Tables

Three Phase

7.5 HP 5.5 kW	Frequency	50 Hz	60 Hz
	Input Speed	1450 RPM	1750 RPM
	Number of Poles	4	

<i>Dimensions:</i>	Frame Size	Page	Frame Size	Page
	HZ522	3.16	HA635	3.18
	HZ523	3.16	HA635	3.19
	HZ524	3.17		

50Hz					60Hz					Selection							
Output Speed (RPM)	Output Torque		Service Factor ^[1]	AGMA Class	Overhung Load		Output Speed (RPM)	Output Torque		Service Factor ^[1]	AGMA Class	Overhung Load		Base			Max Hz ^[2]
	in-lbs	(N·m)			lbs	(N)		in-lbs	(N·m)			lbs	(N)	Motor Power Code	Frame Size	Ratio	
282	1566	177	1.36	I	1254	5580	340	1301	147	1.64	II	1223	5440	8	HZ523	5	120
206	2142	242			1344	5980	248	1779	201			1320	5870			7	
147	2991	338			1421	6320	178	2478	280			1405	6250			10	
119	3717	420			1443	6420	143	3080	348			1441	6410			12	
99.7	4425	500			1457	6480	120	3673	415			1466	6520			15	
292	1513	171	2.00	III	1153	5130	352	1321	149	2.28	III	1138	5060	8	HZ524	5	120
211	2088	236			1210	5380	255	1823	206			1203	5350			7	
146	3027	342			1225	5450	176	2641	298			1243	5530			10	
289	1531	173	2.72	III	1965	8740	349	1332	151	3.11	III	1920	8540	8	HA635	5	120
209	2115	239			2179	9690	252	1845	208			2129	9470			7	
145	3044	344			2293	10200	175	2656	300			2271	10100			10	
117	3770	426			2698	12000	142	3273	370			2630	12200			12	
97.6	4522	511			2810	12500	118	3939	445			2743	12000			15	
71.1	6204	701	2.00		2743	12200	85.9	5142	581	2.40		2698	12000			20	

Selection Tables

Three-Phase

10 HP 7.5 kW	Frequency	50 Hz	60 Hz
	Input Speed	1450 RPM	1750 RPM
	Number of Poles	4	

<i>Dimensions:</i>	Frame Size	Page	Frame Size	Page
	HZ522	3.16	HA635	3.18
	HZ523	3.16	HA635	3.19
	HZ524	3.17		

50Hz					60Hz					Selection							
Output Speed (RPM)	Output Torque		Service Factor ^[1]	AGMA Class	Overhung Load		Output Speed (RPM)	Output Torque		Service Factor ^[1]	AGMA Class	Overhung Load		Base			Max Hz ^[2]
	in-lbs	(N·m)			lbs	(N)		in-lbs	(N·m)			lbs	(N)	Motor Power Code	Frame Size	Ratio	
292	2062	233	1.47	II	1153	5130	352	1707	193	1.76	II	1138	5060	10	HZ524	5	120
211	2850	322			1210	5380	255	2363	267			1203	5350			7	
146	4142	468			1225	5450	176	3425	387			1243	5530			10	
289	2080	235	2.46	III	1965	8740	349	1726	195	2.96	III	1920	8540	10	HA635	5	120
209	2885	326			2179	9690	252	2389	270			2129	9470			7	
145	4150	469	2.00	III	2293	10200	175	3442	389	2.40	III	2271	10100	10	HA635	10	
117	5133	580			2698	12000	142	4248	480			2630	11700			12	
97.6	6177	698			2810	12500	118	5115	578			2743	12200			15	
71.1	8460	956	1.47	II	2743	12200	85.9	7009	792	1.76	II	2698	12000			20	

Note: [1] Selections with service factor marked with an asterisk (*) should be limited to the identified output torque.
 [2] Maximum allowable input speed is 3600rpm unless otherwise noted.
 Variable Frequency Drive (VFD) notes (see page 3.8 for Constant Torque Speed Ranges)
 All 1HP+ motors require EP suffix in model number and can be used with a VFD, unless noted.

Note: [1] Selections with service factor marked with an asterisk (*) should be limited to the identified output torque.
 [2] Maximum allowable input speed is 3600rpm unless otherwise noted.
 Variable Frequency Drive (VFD) notes (see page 3.8 for Constant Torque Speed Ranges)
 All 1HP+ motors require EP suffix in model number and can be used with a VFD, unless noted.

Selection Tables

Three Phase

15 HP 11 kW	Frequency	50 Hz	60 Hz
	Input Speed	1450 RPM	1750 RPM
	Number of Poles	4	

<i>Dimensions:</i>	Frame Size	Page	Frame Size	Page
	HZ522	3.16	HA635	3.18
	HZ523	3.16	HA635	3.19
	HZ524	3.17		

50Hz					60Hz					Selection							
Output Speed (RPM)	Output Torque		Service Factor ^[1]	AGMA Class	Overhung Load		Output Speed (RPM)	Output Torque		Service Factor ^[1]	AGMA Class	Overhung Load		Base			Max Hz ^[2]
	in·lbs	(N·m)			lbs	(N)		in·lbs	(N·m)			lbs	(N)	Motor Power Code	Frame Size	Ratio	
289	3062	346	1.68	II	1965	8740	349	2531	286	2.02	III	1920	8540	15	HA635	5	120
209	4230	478			2178	9690	252	3504	396			2129	9470			7	
145	6088	688			2293	10200	175	5044	570			2271	10100			10	
117	7522	850	1.36	I	2316	10300	142	6230	704	1.64	II	2316	10300			12	
97.6	9027	1020			2360	10500	118	7504	848			2361	10500			15	
71.1	12000	1356			0.96	2133	9490	85.9	12000			1356	1.16			I	

Page intentionally left blank.

BBB-H

Selection Tables

Note: [1] Selections with service factor marked with an asterisk (*) should be limited to the identified output torque.

[2] Maximum allowable input speed is 3600rpm unless otherwise noted.

Variable Frequency Drive (VFD) notes (see page 3.8 for Constant Torque Speed Ranges)

All 1HP+ motors require EP suffix in model number and can be used with a VFD, unless noted.

Gearmotor Dimensions

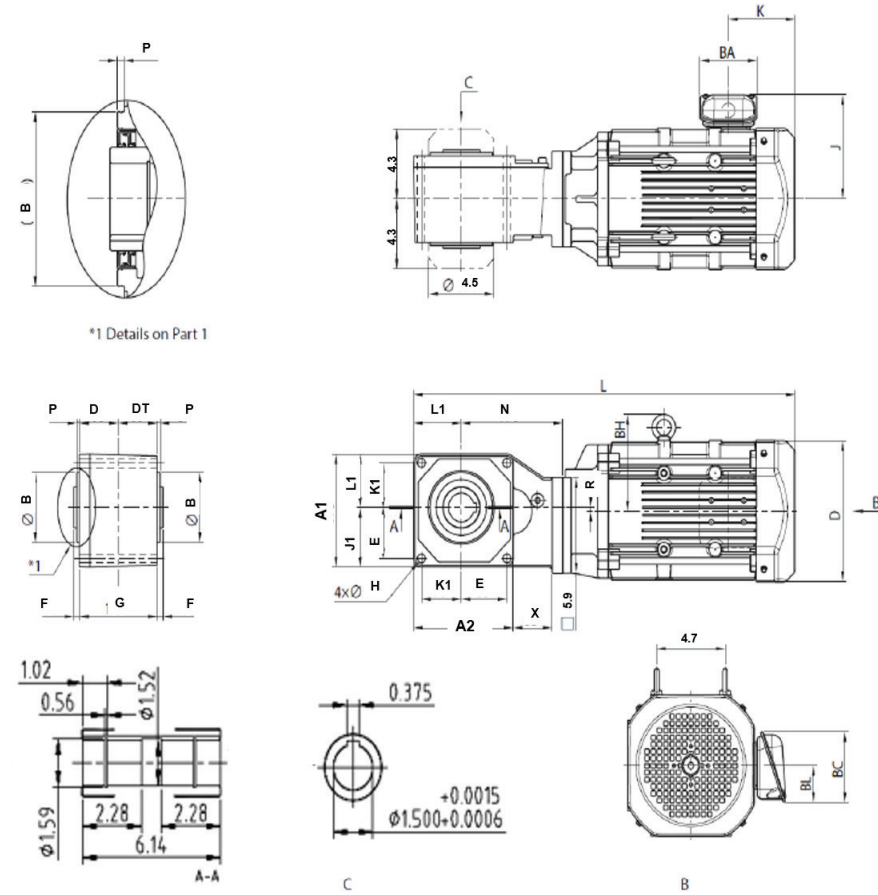

All dimensions are in inches.

Frame Size	Capacity kW x 4	Capacity Code	BH	Dimensions										Terminal box dimension
				J	Without Brake				With Brake					
					K	D	L	Wt. (kg)	K	D	L	Wt. (kg)		
HZ522	2.2	3	4.92	7.02	4.53	7.24	23.31	50	7.60	7.24	26.38	57	a	
	3.7	5	6.02	7.83	4.65	8.74	24.69	61	8.19	8.74	28.23	84		
HZ523	5.5	8	6.02	7.83	4.65	8.74	26.38	73	8.19	8.74	29.92	107		
HZ524	7.5	10	6.85	9.25	5.43	10.24	27.13	89	9.57	10.24	31.26	109	b	

Terminal box dimension	BA	BC	BL
a	4.84	5.94	3.43
b	6.06	7.24	4.13

A1	A2	B min	B max	DT	E	F	G	H	J1	K1	L1	N	P	R	X
7.01	6.89	4.329	4.331	2.68	3.15	0.39	5.35	0.55	3.70	2.75	3.31	7.01	0.20	0.24	2.68

Gearmotor Dimensions

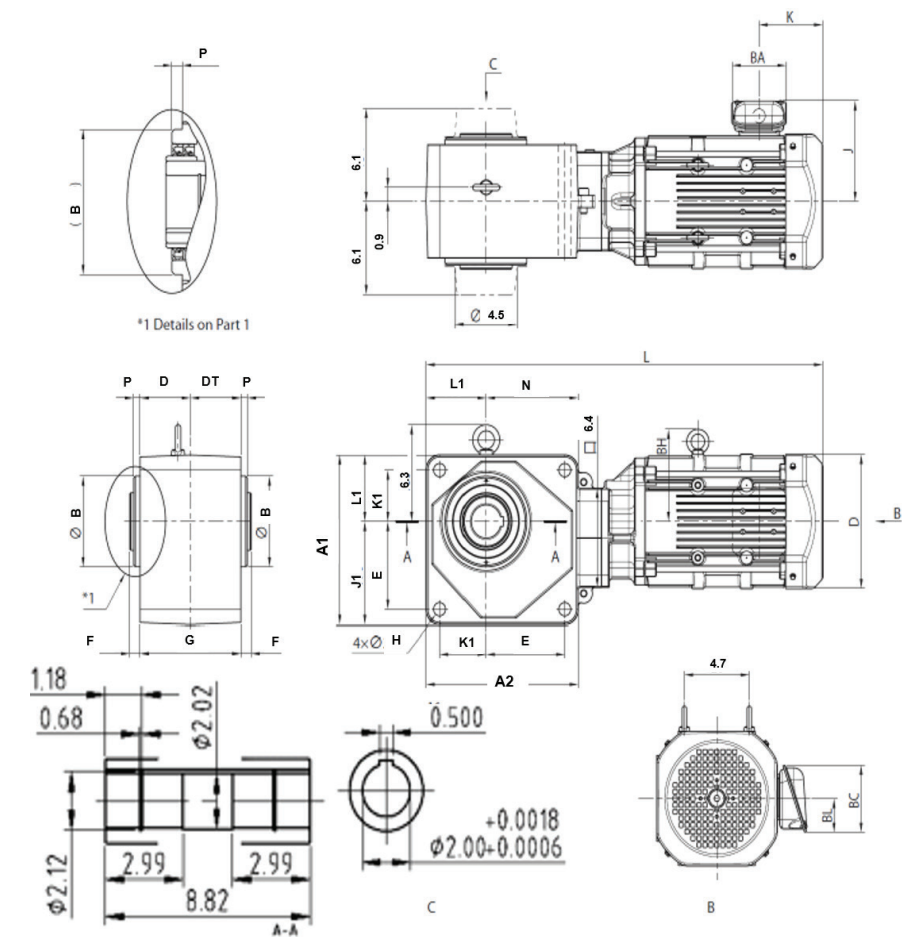

All dimensions are in inches.

Frame Size	Capacity kW x 4	Capacity Code	BH	Dimensions										Terminal box dimension
				J	Without Brake				With Brake					
					K	D	L	Wt. (kg)	K	D	L	Wt. (kg)		
HA635	5.5	8	6.02	7.83	4.65	8.74	28.82	96	8.19	8.74	32.36	107	a	
HA635	7.5	10	6.85	9.25	5.43	10.24	29.72	112	9.57	10.24	33.86	132	b	
	11	15					32.13	130			36.26	150		

Terminal box dimension	BA	BC	BL
a	4.84	5.94	3.43
b	6.06	7.24	4.13

A1	A2	B min	B max	DT	E	F	G	H	J1	K1	L1	N	P	R	X
11.02	11.02	5.904	5.906	3.66	5.71	0.75	7.32	0.87	6.69	3.35	4.33	8.37	0.47	-	6.30

4

Options

T-Type Torque Arm

Frame Size HZ522-HA635

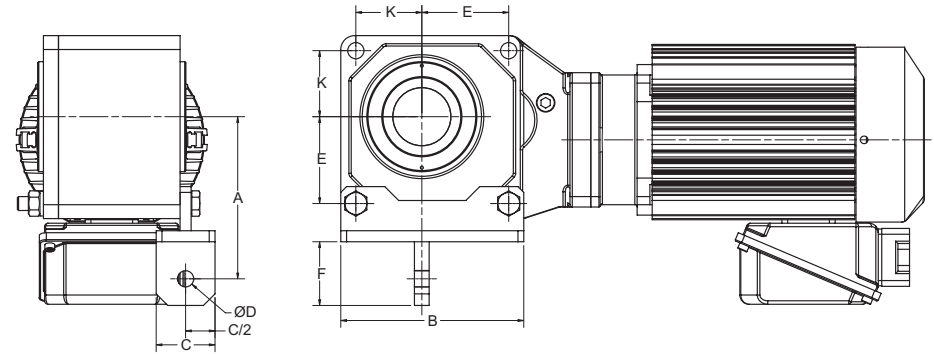

All dimensions are in inches.

Frame	A	B	C	ØD	E	F	K
HZ522							
HZ523	5.67	7.00	2.00	0.55	3.15	2.28	2.76
HZ524							
HA635	10.0	11.0	3.00	0.87	5.71	3.35	3.35

Shaft Dimensions

Symbols: ● KHB Carbon Steel ○ KHB Stainless Steel
Consult factory for price and delivery.

Table 4.1 Hollow Shaft Dimensions (in.)

Bore Size (in.)	Frame Size	
	HZ522 HZ523 HZ524	HA635
1	●○	
1-1/8	●○	
1-3/16	●○	
1-1/4	●○	
1-5/16	●○	
1-3/8	●○	
1-7/16	●○	
1-1/2	●○	
1-5/8	●○	●○
1-11/16	●○	●○
1-3/4	●○	●○
1-7/8		●○
1-15/16		●○
2		●○
2-1/16		●○
2-1/8		●○
2-3/16		●○

Table 4.2 Hollow Shaft Metric Bore Dimensions (mm)

Bore Size (mm)	Frame Size	
	HZ522 HZ523 HZ524	HA635
30	●○	
35	●○	
38	●○	
40	●○	●○
45	●○	●○
50		●○
55		●○

Shrink Disc

A shrink disc provides a reliable, keyless, high-strength connection to the driven shaft with zero backlash. It is ideal for applications that typically require an interference between the shaft and hollow bore. Sumitomo strongly recommends a shrink disc for applications involving frequent starts per hour.

When ordering, use the Special Specification Code (SSC) R61 for right side (when viewed from the motor end), or R62 for left side (when viewed from the motor end).

The user shaft should conform to JIS h6 tolerances. Shafts outside that range may not develop sufficient clamping force. The shaft surface finish should be between 63 to 125 micro-inches RMS.

Table 4.3 Shrink Disc Availability

Bore Size (in.)	Frame Size	
	HZ522 HZ523 HZ524	HA635
1		
1-1/8		
1-3/16		
1-1/4		
1-5/16		
1-3/8	★	
1-7/16	★	
1-1/2	★	
1-5/8	★	
1-11/16	★	
1-3/4	★	
1-7/8		
1-15/16		
2		★
2-1/16		
2-1/8		
2-3/16		

BBB-H

Options

Easy-Grip™

Easy-Grip™ uses unique interchangeable bushings and a shrink disc set to allow easy attachment of the gear reducers to standard available shafting up to h11 tolerances

Table 4.4 Easy-Grip

Bore Size (in.)	Frame Size	
	HZ522 HZ523 HZ524	HA635
1		
1-1/8		
1-3/16		
1-1/4		
1-5/16		
1-3/8		
1-7/16	★	
1-1/2		
1-5/8		
1-11/16	★	
1-3/4		
1-7/8		
1-15/16	★	★
2		
2-1/16		
2-1/8		
2-3/16		

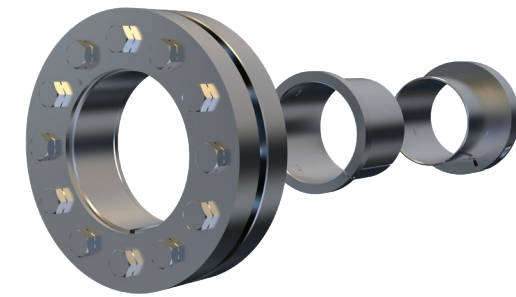

BBB-H

Options

Food Industry Packages

Four food-grade packages are available for use in machinery where there is incidental food contact. (Chemi SHIELD, SHIELD360, Food-Grade, and Ultra SHIELD360)

Page intentionally left blank.

Modification	Chemical Duty	Chemi SHIELD 360*	Low Temp	Weather Proof IP54	Wash-down IP55	Food-Grade	SHIELD 360*	Ultra SHIELD 360*
Motor Portion								
Gasketed Conduit Box	X	X		X	X	X	X	
V Ring Seal- Fan End	X	X		X	X	X	X	
Low Temperature Oil Seal			X					
Special Varnish On Windings			X					
Sealer @ Joints	X	X	X	X	X	X	X	
Special Fan			X					
FDA White Top Coat							X	
FDA Epoxy Paint	X	X			X	X		
Brake Cover and Seal	X	X		X	X		X	
Reducer Portion								
Epoxy Paint	X				X			
FDA White Top Coat							X	
FDA Epoxy Paint		X				X		X
FDA Approved Grease						X		X
Low Temp Grease / Oil			X					
Quad-Lips Acrylic Seals				X	X	X	X	
Low Temperature Seals			X					
FKM Antimicrobial Seals	X	X						X
Stainless Steel Hardware								
Tesa Nameplate	X	X						X
Stainless Steel Output Shaft		X						X

BBB-H

Options

Notes: † Modification list prices are in addition to base unit list price.

Stainless Steel Solid Shaft - maximum torque ratings with standard solid shaft diameters are the same as those listed in this catalog for standard models. Consult the factory when ordering smaller than standard diameters, or if there will be overhung load.

* UltraShield360™ available in quill input option only

Low Temp Package = -30 degrees C Maximum. For lower temperature requirements consult factory.

High Temp Package = 50 degrees C Maximum. For higher temperature requirements consult factory.

BBB-H

Options

5

Technical Information

BBB-H

Technical
Information

Exact Ratios

The exact reduction ratios for the Hyponic can be calculated given the number of gear teeth in a reduction stage.

Per reduction stage, the reduction ratio is determined by dividing the number of teeth in the gear by the number of teeth in the pinion. The overall gearbox reduction ratio is the product of the individual stage reduction ratios.

$$\text{Overall Reduction Ratio} = i_{\text{OVERALL}} = (1\text{ST}_{\text{GEAR}} / 1\text{ST}_{\text{PINION}}) (2\text{ST}_{\text{GEAR}} / 2\text{ST}_{\text{PINION}}) (3\text{ST}_{\text{GEAR}} / 3\text{ST}_{\text{PINION}})$$

where: $1\text{ST}_{\text{GEAR}}, 1\text{ST}_{\text{PINION}}$ = Tooth count of first stage pinion and gear respectively
 $2\text{ST}_{\text{GEAR}}, 2\text{ST}_{\text{PINION}}$ = Tooth count of second stage pinion and gear respectively
 $3\text{ST}_{\text{GEAR}}, 3\text{ST}_{\text{PINION}}$ = Tooth count of third stage pinion and gear respectively (if applicable)

Table 5.1: Tooth Counts and Calculated Reduction Ratios for Nominal Ratios 5-20:1

Normal Ratio	Frame Size	Number of Teeth						Calculated Ratio
		1ST _{PINION}	1ST _{GEAR}	2ST _{PINION}	2ST _{GEAR}	3ST _{PINION}	3ST _{GEAR}	
5	HZ522	11	44	34	43	-	-	5.059
	HZ523	15	45	28	48	-	-	5.143
	HZ524	20	45	24	53	-	-	4.969
	HA635	17	45	29	55	-	-	5.020
7	HZ522	11	44	28	49	-	-	7.000
	HZ523	15	45	23	54	-	-	7.043
	HZ524	20	45	19	58	-	-	6.868
	HA635	17	45	24	63	-	-	6.949
10	HZ522	11	44	22	55	-	-	10.000
	HZ523	15	45	18	59	-	-	9.833
	HZ524	20	45	14	62	-	-	9.964
	HA635	17	45	18	68	-	-	10.000
12	HZ522	11	44	19	58	-	-	12.211
	HZ523	15	45	15	61	-	-	12.200
	HA635	17	45	15	70	-	-	12.353
15	HZ522	11	44	16	61	-	-	15.250
	HZ523	15	45	13	63	-	-	14.538
	HA635	17	45	13	73	-	-	14.864
20	HZ522	11	44	13	63	-	-	19.385
	HA635	17	45	20	44	18	63	20.382

Shaft Rotation

Figure 5.1 Counter Clockwise Ratios

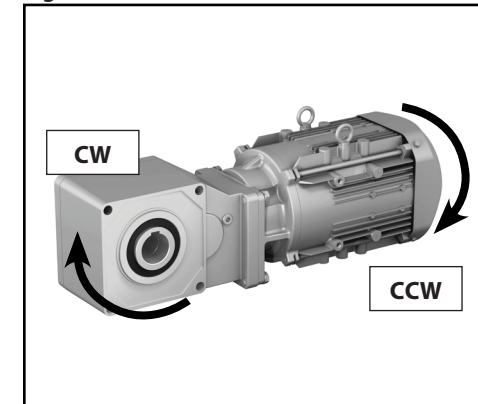

Figure 5.2 Clockwise Ratios

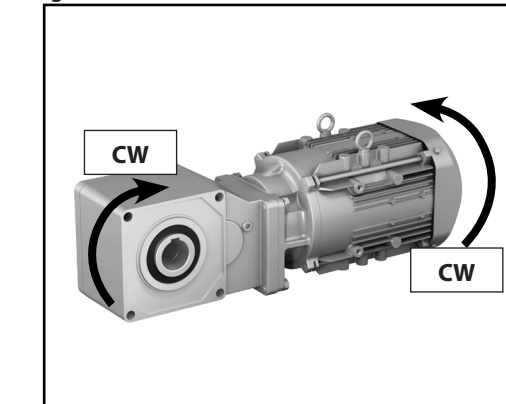

Table 5.2 Shaft Rotation Direction

Model	Counter Clockwise Reduction Ratio (:1)	Clockwise Reduction Ratio (:1)
HZ522	5, 7, 10, 12, 15, 20	-
HZ523	5, 7, 10, 12, 15	-
HZ524	5, 7, 10.	-
HA635	5, 7, 10, 12, 15	20

Special Load Guidelines Inertia

Table 5.3 Reducer Moment of Inertia, Ratios 5 ~ 20

Units: lb-inch² (x 10⁻⁴ kg-m²) for J
Units: lbf-inch² (x10⁻⁴kgfm²) for GD²

Type	Size	Flange	1/5		1/7		1/10		1/12		1/15		1/20	
			J	GD ²	J	GD ²	J	GD ²	J	GD ²	J	GD ²	J	GD ²
For Servo Motor	HZ522	V5P	13.9	55.6	13.5	53.9	13.1	52.5	13.0	51.9	12.9	51.4	12.8	51.2
			13.0	51.9	12.5	50.2	12.2	48.7	12.0	48.2	11.9	47.7	11.9	47.4
	HZ523	V5T	16.7	66.8	16.0	63.9	15.4	61.5	15.0	60.1	14.8	59.4	-	-
			19.8	79.0	18.6	74.5	17.7	70.6	-	-	-	-	-	-
			-	-	-	-	-	-	32.7	131	32.0	128	31.6	126
HA635	V5Z	39.7	159	37.8	151	34.6	139	33.4	133	32.7	131	32.3	129	
For NEMA motor Input hollow shaft	HZ522	182TC,184TC	13.6	54.5	13.2	52.8	12.8	51.4	12.7	50.8	12.6	50.3	12.5	50.1
	HZ523	213TC	16.8	67.4	16.1	64.5	15.5	62.1	15.2	60.7	15.9	60.0	-	-
	HZ524	215TC	19.9	79.6	18.8	75.1	17.8	71.2	-	-	-	-	-	-
	HA635	213TC, 215TC	37.9	151	35.9	144	32.8	131	31.5	126	30.8	123	30.4	122
For NEMA motor Input solid shaft & Adapter	HZ522	182TC,184TC	9.43	37.7	9.00	36.0	8.65	34.6	8.51	34.0	8.38	33.5	8.33	33.3
	HA635	213TC, 215TC	30.3	121	28.3	113	25.1	101	23.9	95.5	23.2	92.7	22.8	91.2

Table 5.4 Premium-efficiency, 3-phase motor

Unit: J_M (Moment of inertia) [xkg-m²]
GD²_M [xkgf-m²]

kW x P	3 HP (2.2 kW) x 4 Pole		5 HP (3.7 kW) x 4 Pole		7.5 HP (5.5 kW) x 4 Pole		10 HP (7.5 kW) x 4 Pole		15 (11 kW) x 4 Pole	
	J _M	GD ² _M	J _M	GD ² _M	J _M	GD ² _M	J _M	GD ² _M	J _M	GD ² _M
Without Brake	0.00880	0.0352	0.0194	0.0777	0.0291	0.116	0.0409	0.164	0.0561	0.224
With Brake	0.00978	0.0391	0.0209	0.0835	0.0306	0.122	0.0450	0.180	0.0602	0.241

Table 5.5 Premium-efficiency, 3-phase motor for inverter

Unit: J_M (Moment of inertia) [xkg-m²]
GD²_M [xkgf-m²]

kW x P	3 HP (2.2 kW) x 4 Pole		5 HP (3.7 kW) x 4 Pole		7.5 HP (5.5 kW) x 4 Pole		10 HP (7.5 kW) x 4 Pole		15 (11 kW) x 4 Pole	
	J _M	GD ² _M	J _M	GD ² _M	J _M	GD ² _M	J _M	GD ² _M	J _M	GD ² _M
Without Brake	0.00880	0.0352	0.0194	0.0777	0.0291	0.116	0.0409	0.164	0.0561	0.224
With Brake	0.00978	0.0391	0.0209	0.0835	0.0306	0.122	0.0450	0.180	0.0602	0.241

Table 5.6 Moment of Inertia on Motor Shaft of N-Frame Integral Motor

Units: lb-inch² (x 10⁻⁴ kg-m²)

3 HP (2.2 kW) x 4 Pole		5 HP (3.7 kW) x 4 Pole		7.5 HP (5.5 kW) x 4 Pole		10 HP (7.5 kW) x 4 Pole		15 HP (11 kW) x 4 Pole	
Standard	w/Brake	Standard	w/Brake	Standard	w/ Brake	Standard	w/ Brake	Standard	w/ Brake
30.1	33.4	66.3	71.4	99.4	105	140	154	192	206
(88)	(97.8)	(194)	(209)	(291)	(306)	(409)	(450)	(561)	(602)

Construction

Construction

Figure 5.3 Hollow Shaft Type Example (LNYM8-HZ523-EP)

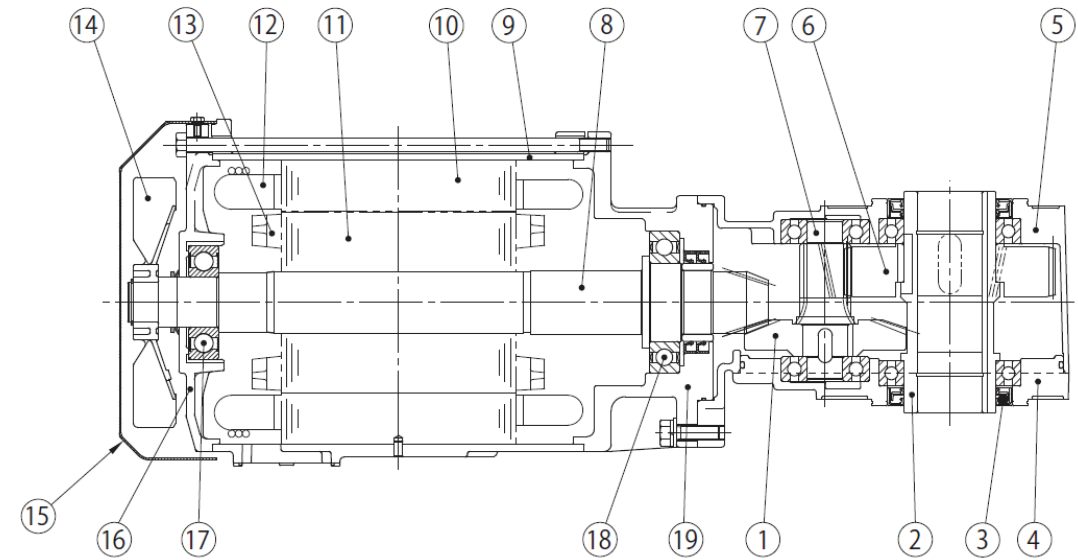

Table 5.7 Hollow Shaft Type Parts

Part No.	Description	Part No.	Description	Part No.	Description
1	Bevel gear	8	Bevel pinion shaft	15	Fan cover
2	Output shaft	9	Motor frame	16	Anti-load side cover
3	Oil seal	10	Stationary core	17	Bearing
4	Case (1)	11	Rotor core	18	Bearing
5	Case (2)	12	Stationary coil	19	Motor flange bracket
6	Gear	13	Rotor conductor		
7	Pinion shaft	14	Fan		

Mounting

Recommended Shaft Tolerances for Hollow Bore BBB-H

According to JIS standard and based on loading conditions, recommended shaft tolerances for hollow bore BBB-H are:

- Steady, uniform loads: **JIS h6/js6 (low shock load)**
- Shock load or large overung load: **JIS js6/k6 (high shock load)**
- Snap ring size is in accordance with: **JIS B2804C**

Refer to tables 5.15 and 5.16 for corresponding shaft diameters.

Table 5.8 Metric Bore Shaft Diameters (mm)

Bore Size	Low Shock Load JIS h6/js6		High Shock Load JIS js6/k6	
	Min	Max	Min	Max
20	19.9870	20.0065	19.9935	20.0150
25	24.9870	25.0065	24.9935	25.0150
30	29.9870	30.0065	29.9935	30.0150
35	34.9840	35.0080	34.9920	35.0180
40	39.9840	40.0080	39.9920	40.0180
45	44.9840	45.0080	44.9920	45.0180
50	49.9840	50.0080	49.9920	50.0180
55	54.9810	55.0095	54.9905	55.0210

Table 5.9 Inch Bore Shaft Diameters (in.)

Bore Size	Low Shock Load JIS h6/js6		High Shock Load JIS js6/k6	
	Min	Max	Min	Max
3/4	0.74950	0.75025	0.74975	0.75060
13/16	0.81200	0.81275	0.81225	0.81310
7/8	0.87450	0.87525	0.87475	0.87560
15/16	0.93700	0.93775	0.93725	0.93810
1	0.99950	1.00025	0.99975	1.00060
1-1/8	1.12450	1.12525	1.12475	1.12560
1-3/16	1.18700	1.18775	1.18725	1.18810
1-1/4	1.24940	1.25030	1.24970	1.25070
1-5/16	1.31190	1.31280	1.31220	1.31320
1-3/8	1.37440	1.37530	1.37470	1.37570
1-7/16	1.43690	1.43780	1.43720	1.43820
1-1/2	1.49940	1.50030	1.49970	1.50070
1-5/8	1.62440	1.62530	1.62470	1.62570
1-11/16	1.68690	1.68780	1.68720	1.68820
1-3/4	1.74940	1.75030	1.74970	1.75070
1-7/8	1.87440	1.87530	1.87470	1.87570
1-15/16	1.93690	1.93780	1.93720	1.93820
2	1.99930	2.00030	1.99970	2.00080
2-1/16	2.06180	2.06280	2.06220	2.06330
2-1/8	2.12430	2.12530	2.12470	2.12580
2-3/16	2.18680	2.18780	2.18720	2.18830

4. Securing the BBB-H Drive to Prevent Movement Away from the Machine Side (Figures 5.5 – 5.7)

Figure 5.4 Secured by Spacer and Snap Ring

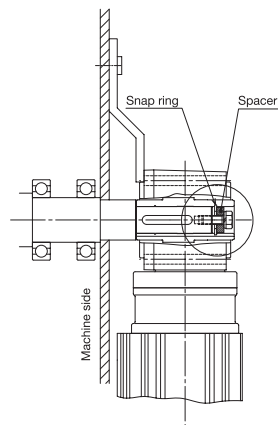

Figure 5.5 Secured by End Plate

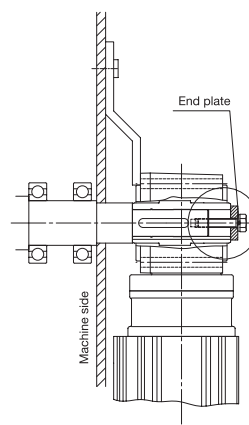
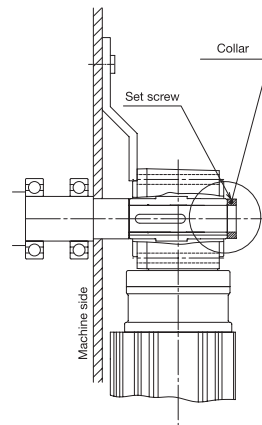

Figure 5.6 Secured by Set Screw and Collar



5. Flange Mounting and Casing Bottom Mounting (optional)

Handle with care. Do not apply excessive force to the driven shaft or hollow shaft by twisting the BBB-H casing. Excessive force on the BBB-H and bearing unit may damage internal parts.

Figure 5.7 Flange Mounting Surface

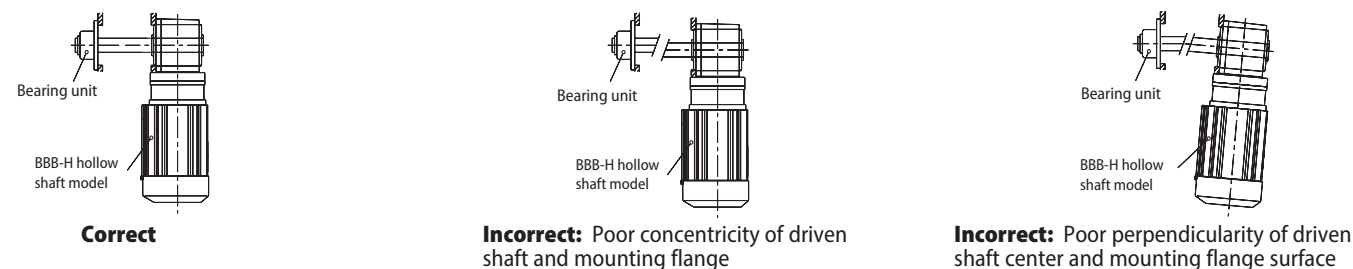

Accessories Output Shaft Safety Cover, Torque Arm

Output Shaft Safety Cover

One safety cover made of resin is attached. Mounting on either the left or right side is possible

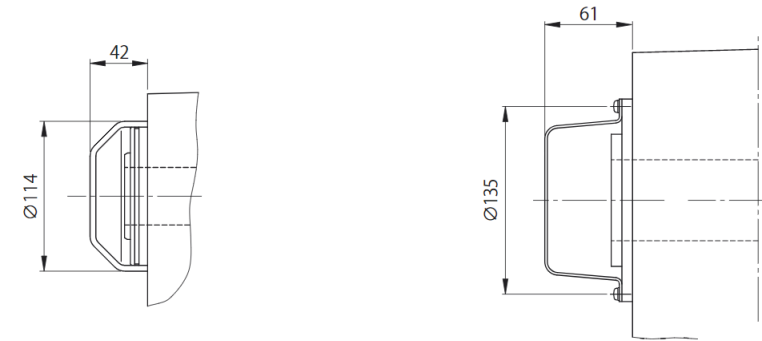

Figure 5.8 Safety cover (for HZ522, HZ523 and HZ524)

Figure 5.9 Safety cover (for HA635)

Torque Arm

Figure 5.10 Recommended Dimensions for customer designed torque arms

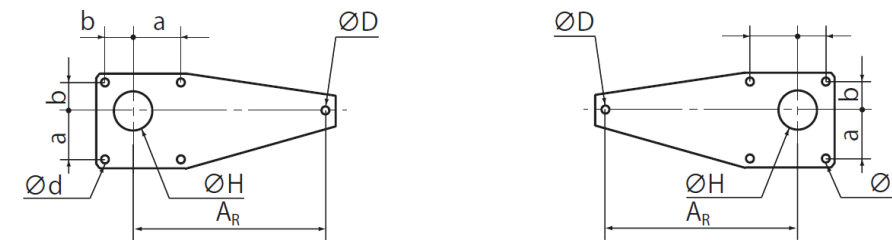

Table 5.11 BBB-H Torque Arm Recommended Dimensions (in.)^[1]

Frame Size	Length	Bore	Stop Hole	Mounting Pitch		Mounting Hole	Thickness
	AR	øH	øD	a	b	ød	
HZ522 HZ523 HZ524	5.91	4.41	0.87	3.15	2.76	0.55	0.35
HA635	11.0	5.98	0.87	5.71	3.35	0.87	0.47

Note 1: These dimensions do not correspond to Sumitomo designed torque arms

Accessories Torque Arm continued

Figure 5.11 BBB-H Torque Arm Mounting Examples

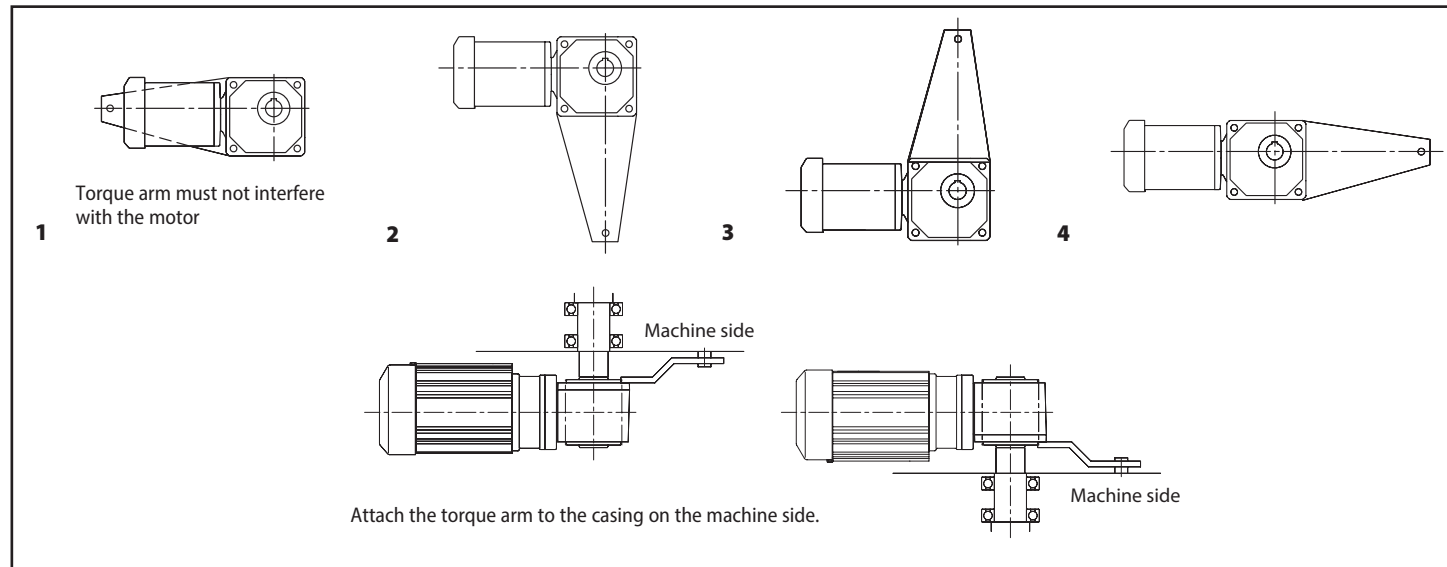

Accessories Torque Arm continued

Torque Arm Mounting:

1. Attach the torque arm to the BBB-H casing on the machine side using hex socket head cap screws. Refer to Table 5.18 for bolt sizes.
2. Leave some clearance between the torque arm and machine, and the torque arm and mounting bolt, so excessive force will not be applied to the BBB-H and driven shaft.
3. For frequent start/stop applications, or repeated normal/reverse operations, use a rubber bushing between the torque arm and mounting bolt (or spacer) to absorb the shock.

Table 5.12 Torque Arm Bolt Sizes

Model	Bolt
HZ522	M20
HZ523	
HZ524	
HA635	

Figure 5.12 BBB-H Torque Arm Clearance

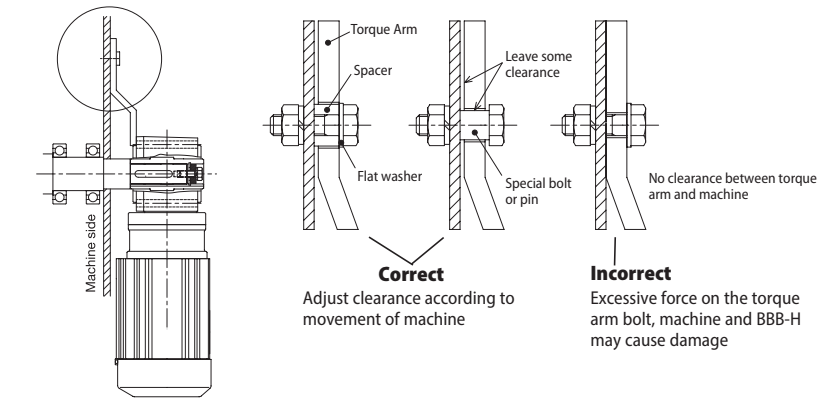

Lubrication

BBB-H drives are filled with long-life grease and sealed, so replenishment is unnecessary, but overhaul in approximately 20,000 hours or three to five years of operation will provide longer service life. Operating conditions affect oil seal durability. Under severe conditions, they may require changing in less than 20,000 hours or three years of operation. Gearmotors must be overhauled at factory-authorized locations.

Table 5.13 BBB-H Greases

Grease	Description	Temperature Range
Nihon Koyu BA-11A	Standard Grease	14°F to 104°F (-10°C to 40°C)
Nihon Koyu BH-17B	Low Temperature Grease	-22°F to 14°F (-30°C to -10°C)
Cassida-SGG 000	Food Grade Grease	14°F to 104°F (-10°C to 40°C)

Paint and Rust-proofing Specifications

Table 5.14 Paint Specifications

Paint Classification	Coating Name	Paint Color	Resin Type	Dry Time (hrs.)
SMA Blue Paint (standard)	Amerloc 2	Blue	High Solids 2 Part Epoxy	1 – 2
Epoxy (optional)	Heavy-Duty Epoxy	Blue	Polymide Converted Epoxy	4 – 6
FDA-USDA (optional)	Food and Beverage Industry Coating	High Gloss White or Silver	Modified Alkyd	4 – 7

- All completely assembled models receive rust-proofing treatment prior to shipment.
- All models for export receive rust-proofing treatment that is effective for 12 months. Please specify "export Rust-proofing" for all export models.
- Please consult factory for storage longer than those listed in Table 5.21 or in the event of adverse storage conditions.

Table 5.15. Rust-proofing Specifications

Rust-Proofing Period	1 Year
Storage Condition	Indoor environment that is relatively free of humidity, dust, extreme temperature fluctuation. corrosive gas, etc.

North American Motor Specifications

Feature	All Motors
Motor Type	3-Phase AC Asynchronous Squirrel Cage Induction Motor
Motor Standard	NEMA
Power Range	3 through 15 HP (2.2 through 11 kW)
Number of Poles	4 Poles
Motor Power Supply	230 / 460 Volts, 60 Hz, 3 phase 575 Volts, 60 Hz, 3 phase
Synchronous RPM (Slip)	1800 RPM (20 - 100 RPM - See Motor Nameplate)
NEMA Design	A or B (See Motor Nameplate)
Efficiency	3 through 15 HP (NEMA Premium Efficiency - IE3)
Motor Temperature Rise	Class B
Motor Insulation	Class F Tropicalized
Service Factor	Sinusoidal Utility Power: 1.15, Inverter Power: 1.0
Time Rating	Continuous
Frame Material	Diecast Aluminum
Enclosure Type	3 HP - 15 HP - TEFC
Enclosure Rating	IP55 Outdoor and Indoor Neoprene v-ring, gaskets and slinger shaft seals
Conduit Box	Outdoor Gasketed Oversized Diecast Aluminum, NPT Conduit Thread (Optional Indoor Steel)
Certification	UL Recognition, CSA Certification, CE Marked
Inverter Compatibility	Motor Insulation MG1 Part 31 Compliant
Constant Torque Speed Range	See Below
Overspeed Operation	Up to 120 Hz Check Reducer and Driven Equipment Overspeed Rating!
Motor Bearings	Double shielded, Deep Groove, Sealed for Life, CM Reduced Clearance Ball Bearings
Fan Guard (TEFC)	Steel
Fan (TEFC)	3 - 15 HP (Nylon Resin - PA66 with 30% Glass Fiber)
Lifting Provisions	(1 - 15 HP) Eyebolt

Feature	Non-Brake Motor	Brake Motor
Constant Torque Speed Range	See page 3.8 for table.	See page 3.8 for table.
208V Motor Power	Usable on 208V Network	Motor usable on 208V network but supply 230V for brake control
Brake Power Supply	-----	230 / 460 Volts, 60 Hz, 1 phase 575 Volts, 60 Hz, 1 phase
Brake Insulation	-----	Class F
Manual Brake Release Mechanism	-----	3- 15 HP - one-touch lever type release

Terminal Box Specification

Terminal box installation position, cable lead wire direction

The terminal box installation position of the motor and the cable lead wire direction can be selected in 90 degree pitches from the standard installation position and direction. Specify at the time of ordering according to the diagram below. (The terminal box installation position cannot be changed after shipment. Always specify at the time of ordering.)

Figure 5.13

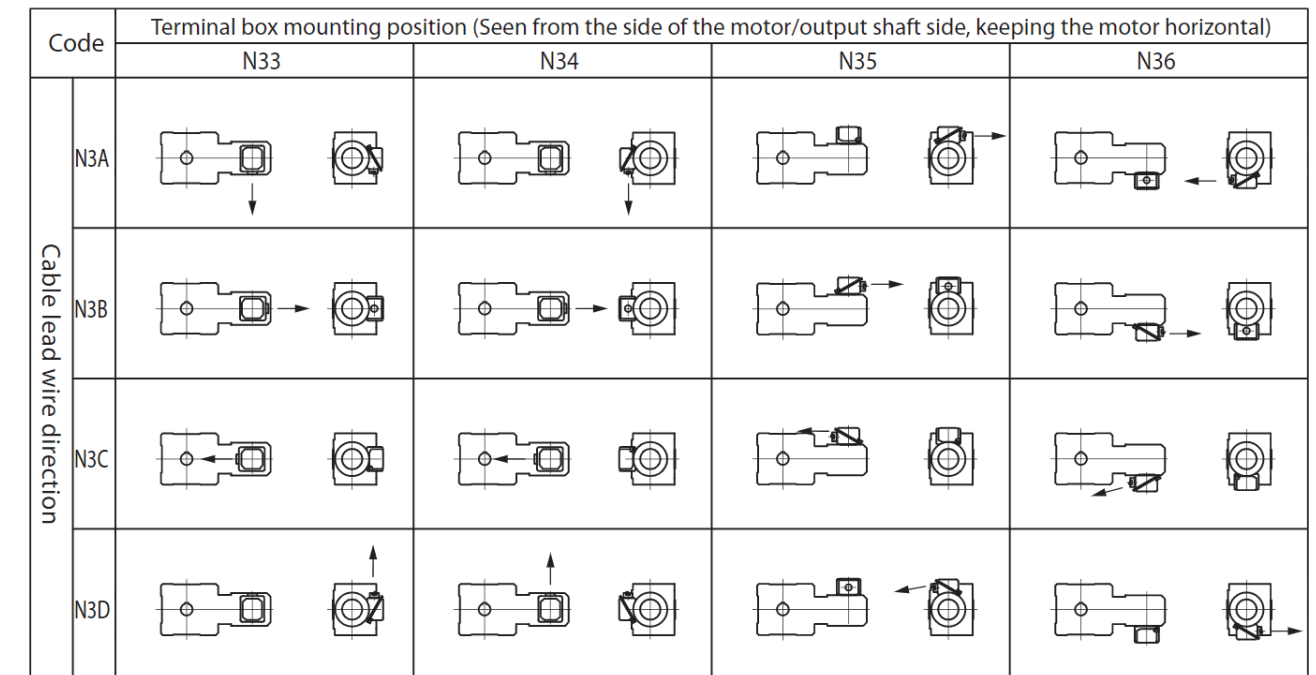

Terminal box mounting position and lead wire cable port direction (Standard ver.)

	Indoor type	Outdoor type
Terminal box mounting position	N33	N33
Wire cable port	N3A	N3B

BBB-H

BBB-H

Technical Information

Technical Information

**Motor Installation:
Fan/Brake Cover Clearance Requirements**

Required gearmotor clearance dimension FA and FB for installation to achieve best performance and proper maintenance.

Dimension FA: Clearance necessary to remove fan cover or brake cover without moving the gearmotor.

Dimension FB: Minimum clearance to provide adequate airflow for ventilating the motor.

Notes: 1. In some cases, it may be necessary to move the gearmotor to remove the fan cover or brake cover.

Figure 5.14 Motor End Clearance

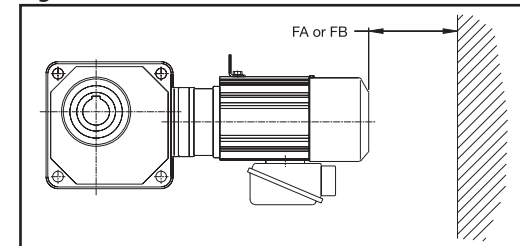
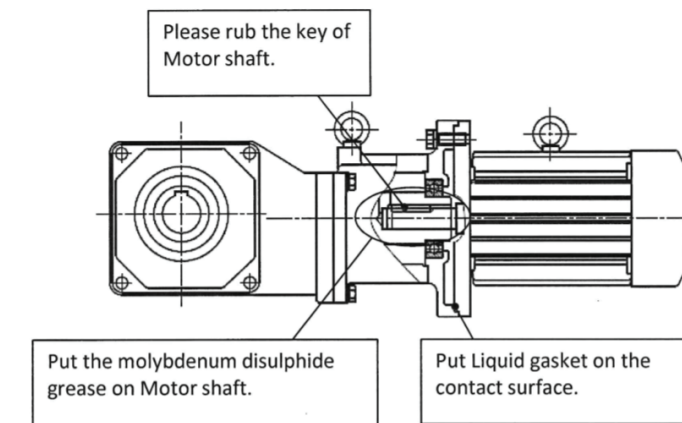

Table 5.16 Motor Clearance Requirements for EP motors (1 to 15 hp)

Frame Size	IE3 Motor		3-Phase Without Brake Motor		3-Phase Brake (B) Motor	
	HP x Pole	kW x Pole	FA	FB	FA	FB
N-100L	3 x 4	2.2 x 4	2.4 (60)	0.8 (20)	5.4 (138)	0.8 (20)
N-112M	5 x 4	3.7 x 4	2.5 (63)	1.0 (25)	6.0 (153)	0.8 (20)
N-132S	7.5 x 4	5.5 x 4				
N-132M	10 x 4	7.5 x 4	3.3 (84)	1.2 (30)	7.4 (189)	1 (25)
N-160M	15 x 4	11 x 4	4.2 (107)	1.2 (30)	9.5 (242)	1.2 (30)
N-160L	20 x 4	15 x 4				

- Please take the following process to put the motor shaft in the input hollow shaft smoothly beforehand.
 - Rub the key of motor shaft to meet the keyseat of input hollow shaft. (The keyseat for Servo motor is based on JIS B 1301-1996 for normal parallel key)
 - Put the molybdenum disulphide grease on the motor shaft and Liquid gasket on the contact surface with the motor.
- Spacer may be included depending on the combination with the motor. Put the spacer in the input hollow shaft before assembling BBB-H reducer with the motor. Without the spacer can be cause of damage.
- Please check centering the motor shaft and the input hollow shaft carefully. (No inclination of the shaft, mis-centering and contacting locally.) Don't bang the reducer or motor strongly with a hammer to assemble.
- Please check applying the inlay correctly before fastening the bolts.
- Failure to follow the above notice result in large thrust forces acting on the internal bearings, causing damage.



Allowable moment of motor

If the motor weight increases, the case may be damaged and the motor may fall. The moment value of the motor should be within the allowable value in the below table. If the value exceeds the allowable value, please support the motor.

Input hollow shaft type (for Servo motor & NEMA motor)

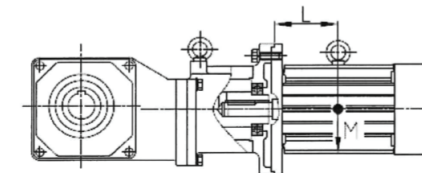

Size	Allowable moment L x M N·m
HZ522, HZ523, HZ524	170
HA635	170

Input solid shaft(for NEMA motor)

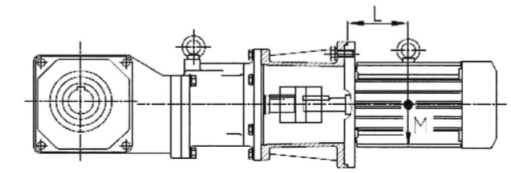

Size	Allowable moment L x M N·m
HZ522	80
HA635	170

Motor Conduit Box Details

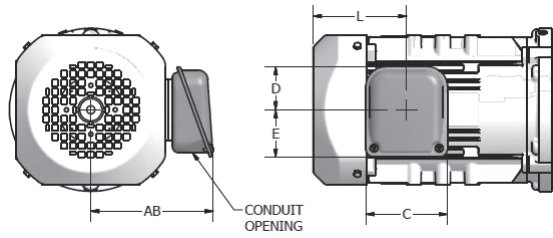

Figure 5.15 Indoor Duty (Optional) Box

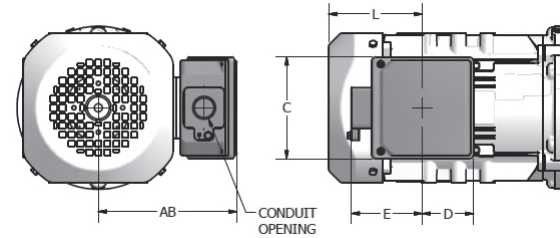

Figure 5.16 Global EP.NA and Outdoor Duty Box

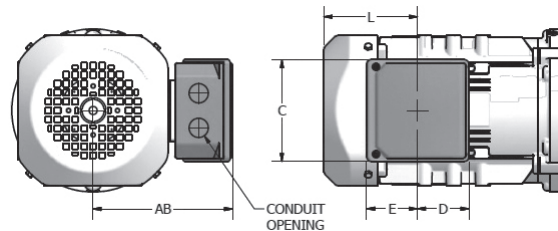

Figure 5.17 Global IE3 CE Box

Table 5.17 Conduit Box Information

inch (mm)

Frame Size	Duty Rating	General Dimensions				Without Brake		With Brake		Conduit Opening	Material
		AB	C	D	E	Availability	L	Availability	L		
N-100L N-112S	Indoor Duty (Optional)	5.93 (151)	3.94 (100)	2.09 (53)	2.29 (58)	Yes	4.53 (115)	CF ⁽¹⁾	7.60 (193)	Ø0.90 (Ø23)	Steel
	Indoor Duty Brake (Optional)	6.72 (171)	4.80 (122)	2.60 (66)	2.84 (72)			Yes		Ø0.90 (Ø23)	Steel
	Outdoor Duty (Optional)	7.21 (183)	4.84 (123)	2.52 (64)	3.43 (87)			Yes		G3/4 ⁽²⁾	Steel
	Global EP.NA	6.71 (170)	4.92 (125)	2.50 (64)	3.43 (87)			Yes		NPT3/4 ⁽²⁾	Al Diecast
	Global IE3 CE	6.75 (172)	4.92 (125)	2.50 (64)	2.47 (63)			Yes		2 - M25	Al Diecast
N-112M	Indoor Duty (Optional)	6.56 (167)	3.94 (100)	2.09 (53)	2.29 (58)	Yes	4.65 (118)	CF ⁽¹⁾	8.21 (209)	Ø0.90 (Ø23)	Steel
	Indoor Duty Brake (Optional)	7.35 (187)	4.80 (122)	2.60 (66)	2.84 (72)			Yes		Ø0.90 (Ø23)	Steel
	Outdoor Duty (Optional)	7.84 (199)	4.84 (123)	2.52 (64)	3.43 (87)			Yes		G3/4 ⁽²⁾	Steel
	Global EP.NA	7.34 (186)	4.92 (125)	2.50 (64)	3.43 (87)			Yes		NPT3/4 ⁽²⁾	Al Diecast
	Global IE3 CE	7.38 (188)	4.92 (125)	2.50 (64)	2.47 (63)			Yes		2 - M25	Al Diecast
N-132S	Indoor Duty (Optional)	6.56 (167)	3.94 (100)	2.09 (53)	2.29 (58)	Yes	4.65 (118)	CF ⁽¹⁾	8.21 (209)	Ø0.90 (Ø23)	Steel
	Indoor Duty Brake (Optional)	7.35 (187)	4.80 (122)	2.60 (66)	2.84 (72)			Yes		Ø0.90 (Ø23)	Steel
	Outdoor Duty (Optional)	7.84 (199)	4.84 (123)	2.52 (64)	3.43 (87)			Yes		G1 ⁽²⁾	Steel
	Global EP.NA	7.34 (186)	4.92 (125)	2.50 (64)	3.43 (87)			Yes		NPT1 ⁽²⁾	Al Diecast
	Global IE3 CE	7.38 (188)	4.92 (125)	2.50 (64)	2.47 (63)			Yes		2 - M25	Al Diecast
N-132M	Indoor Duty (Optional)	7.98 (203)	4.80 (122)	2.60 (66)	2.84 (72)	Yes	5.43 (138)	Yes	9.57 (243)	Ø1.69 (Ø43)	Steel
	Outdoor Duty (Optional)	9.26 (235)	6.06 (154)	3.11 (79)	4.13 (105)					G1 ⁽²⁾	Steel
	Global EP.NA	9.04 (230)	6.69 (170)	3.40 (86)	4.43 (113)					NPT1 ⁽²⁾	Al Diecast
	Global IE3 CE	9.04 (230)	6.69 (170)	3.40 (86)	3.51 (89)					2-M32	Al Diecast

(1) Consult factory for brake configuration supporting this conduit box.
 (2) Default thread option shown. Alternate thread options available. Please consult factory for alternate conduit thread options.

Table 5.17 Conduit Box Information (cont.)

inch (mm)

N-160M	Indoor Duty (Optional)	7.98 (203)	4.80 (122)	2.60 (66)	2.84 (72)	Yes	5.43 (138)	Yes	9.57 (243)	Ø1.69 (Ø43)	Steel
	Outdoor Duty (Optional)	9.26 (235)	6.06 (154)	3.11 (79)	4.13 (105)					G1-1/4 ⁽²⁾	Steel
	Global EP.NA	9.04 (230)	6.69 (170)	3.40 (86)	4.43 (113)					NPT1-1/4 ⁽²⁾	Al Diecast
	Global IE3 CE	9.04 (230)	6.69 (170)	3.40 (86)	3.51 (89)					2-M32	Al Diecast

(1) Consult factory for brake configuration supporting this conduit box.
 (2) Default thread option shown. Alternate thread options available. Please consult factory for alternate conduit thread options.

Motor Performance Data - EP.NA Motor, 60Hz Operation

Table 5.18 Three Phase, 230/460v, 60Hz, 1800 RPM Synchronous Speed, TEFC

Units: inches (mm)

Motor Power HP (kW)		Frame Size	Full Load			Current (A)				Starting Torque % of FL	Breakdown Torque % of FL	Nominal Efficiency %	Power Factor %	NEMA Code Letter
			Rated RPM	Torque		Full Load		No Load % of FL	Starting % of FL					
				in-lbs	N-m	230V	460V							
3	2.2	N-100L	1740	107	12.1	7.66	3.83	47.5	824	317	389	89.5	80.7	K
5	3.7	N-112M	1750	179	20.2	12.3	6.17	44.5	821	244	379	89.5	83.9	K
7.5	5.5	N-132S	1760	264	29.8	17.8	8.90	42.9	1000	290	461	91.7	84.2	L
10	7.5	N-132M	1760	360	40.7	24.4	12.2	36.1	606	193	277	91.7	84.1	G
15	11	N-160M	1770	525	59.3	38.4	19.2	48.0	736	274	369	92.4	77.8	J

Table 5.19 Three Phase, 240/480V, 60Hz, 1800 RPM Synchronous Speed, TEFC

Units: inches (mm)

Motor Power HP (kW)		Frame Size	Full Load			Current (A)				Starting Torque % of FL	Breakdown Torque % of FL	Nominal Efficiency %	Power Factor %	NEMA Code Letter
			Rated RPM	Torque		Full Load		No Load % of FL	Starting % of FL					
				in-lbs	N-m	240V	480V							
3	2.2	N-100L	1750	106	12.0	7.53	3.77	52.1	911	352	446	89.5	78.4	L
5	3.7	N-112M	1760	178	20.1	12.1	6.06	49.3	886	268	421	89.5	81.7	K
7.5	5.5	N-132S	1760	264	29.8	17.5	8.76	47.6	1060	321	506	91.7	82.0	M
10	7.5	N-132M	1760	360	40.7	23.8	11.9	40.3	652	212	308	91.7	82.2	H
15	11	N-160M	1770	525	59.3	38.7	19.3	54.0	760	305	405	92.4	74.0	K

Motor Performance Data - EP.NA Motor, 60Hz Operation (continued)

Table 5.20 Three Phase, 575V, 60Hz, 1800 RPM Synchronous Speed, TEFC

Units: inches (mm)

Motor Power HP (kW)		Frame Size	Full Load			Current (A)			Starting Torque % of FL	Breakdown Torque % of FL	Nominal Efficiency %	Power Factor %	NEMA Code Letter
			Rated RPM	Torque		Full Load	No Load % of FL	Starting % of FL					
				in-lbs	N-m								
3	2.2	N-100L	1740	107	12.1	3.05	47.2	839	322	404	89.5	80.8	K
5	3.7	N-112M	1750	179	20.2	4.86	42.0	798	230	355	89.5	84.9	J
7.5	5.5	N-132S	1760	264	29.8	7.12	42.5	957	263	429	91.7	84.7	L
10	7.5	N-132M	1760	360	40.7	10.1	43.9	704	230	332	91.7	81.3	H
15	11	N-160M	1760	528	59.7	14.5	41.7	710	237	331	92.4	82.3	H

BBB-H

Technical
Information

BBB-H

Technical
Information

Motor Performance Data - IE3 CE Motor, 50Hz Operation

Table 5.21 Three Phase, 220/380V, 50Hz, 1800 RPM Synchronous Speed, TEFC

Units: inches (mm)

Motor Power HP (kW)		Frame Size	Full Load			Current (A)				Starting Torque % of FL	Breakdown Torque % of FL	Nominal Efficiency %	Power Factor %	NEMA Code Letter
HP	kW		Rated RPM	Torque		Full Load		No Load % of FL	Starting % of FL					
				in-lbs	N-m	220V	380V							
3	2.2	N-100L	1440	129	14.6	8.58	4.96	52.2	758	344	418	88.6	78.0	K
4	3.0	N-112S	1430	177	20.0	11.3	6.50	45.6	676	316	365	87.7	80.8	J
5	3.7	N-112M	1460	214	24.2	13.5	7.80	48.5	743	266	378	89.6	81.2	J
5.5	4.0	N-112M	1450	233	26.3	14.4	8.30	45.2	692	266	378	88.9	82.9	J
7.5	5.5	N-132S	1460	318	36.0	-	11.5	49.6	907	316	471	90.6	80.7	L
10	7.5	N-132M	1460	434	49.1	-	15.8	44.9	590	213	315	90.8	79.6	H
15	11	N-160M	1460	636	71.9	-	22.3	38.5	551	200	283	91.4	81.6	G

Table 5.22 Three Phase, 230/400V, 50Hz, 1800 RPM Synchronous Speed, TEFC

Units: inches (mm)

Motor Power HP (kW)		Frame Size	Full Load			Current (A)				Starting Torque % of FL	Breakdown Torque % of FL	Nominal Efficiency %	Power Factor %	NEMA Code Letter
HP	kW		Rated RPM	Torque		Full Load		No Load % of FL	Starting % of FL					
				in-lbs	N-m	230V	400V							
3	2.2	N-100L	1450	128	14.5	8.56	4.95	60.2	798	382	465	88.7	74.1	L
4	3.0	N-112S	1440	176	19.9	11.2	6.45	53.2	727	352	419	87.9	76.9	K
5	3.7	N-112M	1460	214	24.2	13.7	7.90	56.0	766	294	420	89.0	77.5	K
5.5	4.0	N-112M	1460	231	26.2	14.4	8.30	53.4	733	273	388	89.1	78.8	K
7.5	5.5	N-132S	1460	318	36.0	-	11.6	56.6	937	351	524	90.6	76.2	M
10	7.5	N-132M	1460	434	49.1	-	16.0	51.9	704	206	350	91.2	75.5	K
15	11	N-160M	1470	632	71.5	-	22.2	54.4	635	257	378	91.5	73.0	J

Motor Performance Data - EP.NA Motor, 60Hz Operation (continued)

Table 5.23 Three Phase, 240/415V, 50Hz, 1800 RPM Synchronous Speed, TEFC

Units: inches (mm)

Motor Power HP (kW)		Frame Size	Full Load			Current (A)				Starting Torque % of FL	Breakdown Torque % of FL	Nominal Efficiency %	Power Factor %	NEMA Code Letter
HP	kW		Rated RPM	Torque		Full Load		No Load % of FL	Starting % of FL					
				in-lbs	N-m	240V	415V							
3	2.2	N-100L	1450	128	14.5	8.83	5.10	66.1	805	412	502	88.3	69.3	M
4	3.0	N-112S	1440	176	19.9	11.3	6.55	59.8	751	387	458	87.9	73.2	L
5	3.7	N-112M	1460	214	24.2	13.9	8.00	62.5	788	319	453	89.2	72.7	L
5.5	4.0	N-112M	1460	231	26.2	14.5	8.35	59.7	752	294	418	89.0	74.8	K
7.5	5.5	N-132S	1470	316	35.7	-	11.9	64.1	958	378	564	90.2	72.0	N
10	7.5	N-132M	1470	431	48.7	-	16.2	58.5	629	254	378	90.6	71.1	J
15	11	N-160M	1470	632	71.5	-	22.4	50.6	617	249	354	91.6	74.6	H

BBB-H

Technical Information

BBB-H

Technical Information

Motor Selection Considerations for Inverter (VFD) Operation

Benefits:

Operating a three-phase AC Motor with an Inverter (Variable Frequency Drive – VFD) brings benefits to the design of a process control system:

- Extending a motor’s acceleration time (soft starting) can greatly reduce motor starting current levels. Inrush current is limited typically to 150% of a motor’s ampere ratings.
- Controlled and extended acceleration and deceleration rates reduce or eliminate the stress of high torque demands on the motor, reducer and driven load.
- Motor speed can be infinitely adjusted electronically to operate the process at the optimum speed.
- Full-rated motor torque levels can be applied to the load over as much as a 10:1 speed range (6 to 60 Hz, approximately 180 to 1800 RPM motor shaft speed). *(See note on next page about Constant Torque Speed Range)*
- Overspeed operation: within the operating limits of the motor, reducer and driven load, motor speed range can be extended beyond 60 Hz (1800 RPM). *(See note on next page about Constant Horsepower Speed Range)*
- Regulation of motor speed and/or torque without additional feedback devices.
- A properly sized and adjusted Sensorless Flux Vector AC drive can regulate motor shaft speed to almost eliminate motor slip over the motor’s entire loading range.
- Electronic programmable motor torque limiting.
- Electronic overload and short circuit protection for the motor.
- Electronic Reversing: upon command, a VFD will follow preprogrammed deceleration rate to stop motor and then follow acceleration rate to bring motor to commanded speed in reverse direction. No additional power or mechanical components needed to reverse the motor.
- Motor braking (up to 150% of motor rated torque level with optional VFD components).
NOTE: VFDs do not provide HOLDING brake capability. VFDs can be used to sequence a motor-mounted holding brake.
- Many VFDs include basic process control functions and easily interface with Programmable Logic Controllers for more advance process control schemes.
- Serial communication capability for remote monitoring of motor, VFD and process status.
- Within a small limited HP range, VFDs can be selected to power a three-phase 230V motor from a single phase 240V power feed.

Constant Torque Operation:

For most gearmotor applications, a constant-torque rated VFD is required.

Constant-torque rated VFDs carry various manufacturer designations:

- Constant Torque, Heavy Duty or Normal Duty.

All constant-torque rated VFDs carry a 60-second ampere overload capability level of 150% of the VFD’s continuous output ampere rating.

VFDs that offer a 110% or 120% 60-second ampere overload capability are designed for variable-torque type loads like fans and pumps with propellers and impellers and are most likely undersized for gearmotor applications.

When a VFD applies power to a motor, it simultaneously varies both the applied motor voltage level (amplitude) and the motor frequency (Hz) so that the torque delivered at the motor shaft can be held constant from a motor’s base speed (typically 60 Hz) down to below 20 Hz.

The lower frequency limit is dependent on the design complexity of the VFD:

Basic V/Hz control (6 Hz), Sensorless Vector control (0.6 Hz), full Flux Vector control (0.06 Hz).

To achieve the Vector levels of motor control, the VFD must control only one motor, the VFD and motor must be closely matched in power ratings and the VFD must be properly adjusted, perhaps even “tuned” to the motor.

Most electrical motors are not designed to operate continuously at such low frequencies.

(See note on next page about Constant Torque Speed Range)

Motor Selection Considerations for Inverter (VFD) Operation (cont.)

Constant Horsepower (CHP) Operation:

It may be possible to configure a VFD to operate a motor at speeds beyond the motor’s base frequency (typically 60 Hz – 1800 RPM).

To avoid unsafe and unreliable operation, never power a motor, reducer or a driven load beyond the manufacturer’s maximum safe operating speed.

See “Motor Specifications” on page (5.15) for the Sumitomo motor maximum operating speed rating. Consult Sumitomo factory for the Hyponic reducer maximum operating speed rating. Consult the manufacturer of the driven load for its maximum operating speed rating.

A motor’s full-load power rating is the product of its full-load torque rating and its base speed rating. A motor’s power rating does not increase when it is operated above its base speed.

Operation above a motor’s base frequency is called Constant Horsepower (CHP) operation. When a motor is operated above its base frequency, its output torque capability drops as its frequency is increased.

Constant Torque Speed Range (CTSR):

Most motors are not designed to operate for prolonged periods of time at low speed (typically below 20 Hz).

Most motors (i.e TEFC) depend upon a motor shaft-mounted fan for ventilation.

When the motor is operating at low speed, this motor shaft-mounted fan does not provide sufficient air movement to keep the motor’s internal temperature within proper operating limits.

Operating a motor continuously beyond its CTSR can result in premature motor failure.

Be sure to properly configure the VFD’s motor overload protection to match the motor type.

Motors listed for control by a VFD at low speed have been specifically designed to dissipate the heat through means other than the motor shaft-mounted fan.

A motor’s ability to operate continuously at low speed is defined by its CTSR or Constant Torque Speed Range.

Examples of a CTSR rating are: 4:1, 6:1, 10:1.

A motor with a CTSR rating of 4:1 can operate continuously at 15 Hz (60 Hz / 4 = 15 Hz).

A motor with a CTSR rating of 10:1 can operate continuously at 6 Hz (60 Hz / 10 = 6 Hz).

See “Constant Torque Speed Ranges: Gearmotors” on page 3.8 for the Sumitomo motor constant torque speed rating (CTSR).

Consult the instructional material supplied with the VFD for additional important information.

Motor continued

Standard Wiring Diagrams

Illustrated below are the wiring diagrams for our standard motors. For additional information please refer to the motor name plate. Due to changes in design features, this diagram may not always agree with that on the motor. If different, the motor diagram found inside the conduit box cover should be used.

Three-Phase EP.NA Motor

Table 5.24 Wiring Configuration for 230/460V, 60Hz and 575V, 60Hz by EP.NA Motor

Motor HP x P	230/460V, 60Hz			575V, 60Hz		
	Internal	No. of Leads	Diagram	Internal	No. of Leads	Diagram
3 x 4	WYE	9	9-Lead WYE	WYE	3	3-Lead
5 x 4						
7.5 x 4						
10 x 4						
15 x 4	DELTA	9	9-Lead DELTA	DELTA	3	3-Lead
20 x 4						
25 x 4						
30 x 4						
40 x 4						
50 x 4						
60 x 4						
75 x 4						

Figure 5.17 EP.NA - WYE

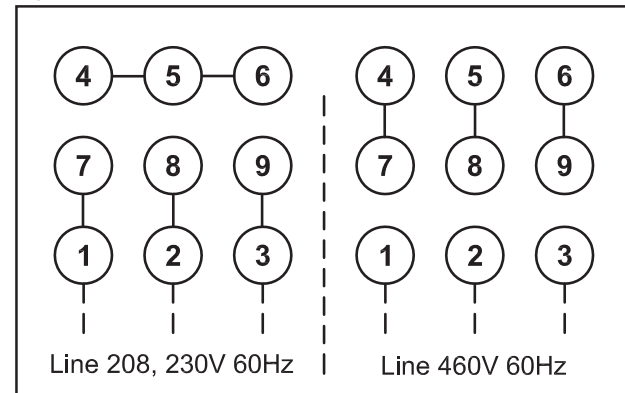

Figure 5.18 EP.NA - DELTA

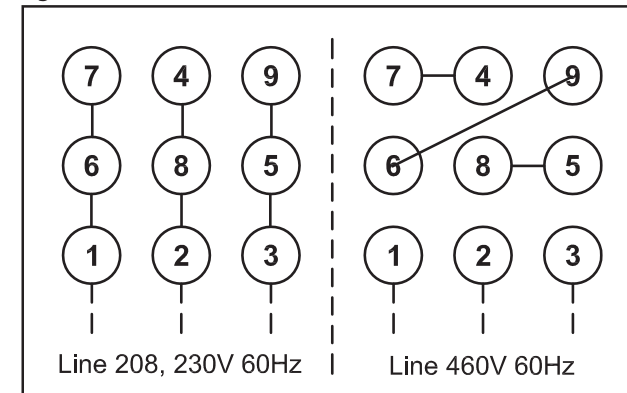
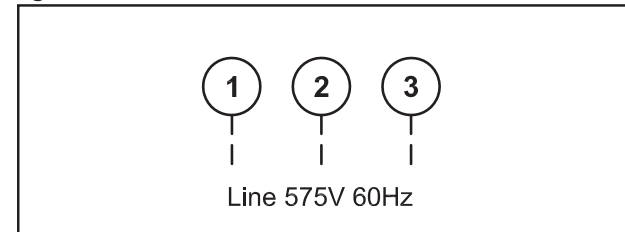

Figure 5.19 EP.NA - SINGLE



Motor continued

Table 5.25 Wiring Configuration by IE3 CE Motor

Motor kW x P	Voltage Configuration	Wiring Diagram
2.2 x 4	220/380V, 50Hz Three Phase	DELTA-WYE
3.0 x 4		
3.7 x 4		
5.5 x 4	380V, 50Hz Three Phase	WYE-Start DELTA-Run
7.5 x 4		
11 x 4		

Figure 5.20 DELTA-WYE Diagram

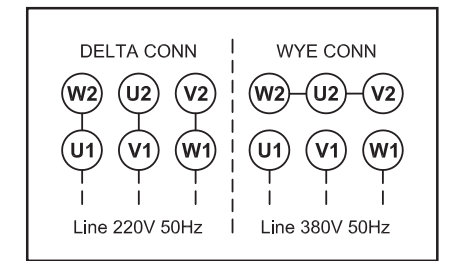
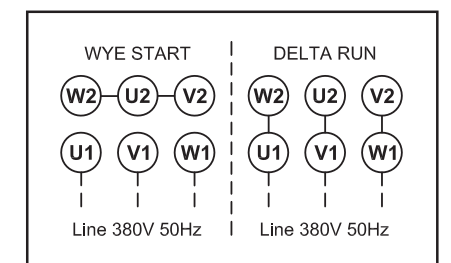

Figure 5.21 WYE-Start DELTA-Run Diagram



Motor Thermal Rating for Cyclic Applications

Table 5.26 Motor Thermal Rating Table

Motor Power HP (kW)	Allowable C x Z				Motor Inertia lb-in ² (kg-m ²)	
	below 35% ED ^[1]	35% ~ 50% ED ^[1]	50% ~ 80% ED ^[1]	80% ~ 100% ED ^[1]	Standard	with Brake
3 (2.2)	1000	900	400	200	30.1 (0.0088)	33.4 (0.00978)
5 (3.7)	800	800	800	700	66.3 (0.0194)	71.4 (0.0209)
7.5 (5.5)	300	300	200	150	99.4 (0.0291)	105 (0.0306)
10 (7.5)	400	350	300	300	140 (0.0409)	154 (0.045)
15 (11)	200	200	150	150	192 (0.0561)	206 (0.0602)

Note: [1] % ED = Duty Cycle.

The calculated C x Z value (steps 1 – 3 outlined below) should be less than the allowable value listed in Motor Thermal Rating table above.

1. Obtain the C value:

$$C = \frac{I_M + I_L}{I_M}$$

I_M = Moment of Inertia of the Motor.
 I_L = Moment of Inertia of the Load as seen from the motor shaft.

2. Obtain the Z value (number of starts per hour):

(a) Assume that one operating period consists of “on-time” t_a (sec.), “off-time” t_b (sec.) and the motor is started nr (times/cycle).

$$Z_r = \frac{3600 \cdot nr}{t_a + t_b} \text{ (times/hour)}$$

(b) When inching, ni (times/cycle) is included in 1 cycling (t_a+t_b), the number of inching times per hour Z_i , is then included in the number of starts.

$$Z_i = \frac{3600 \cdot ni}{t_a + t_b} \text{ (times/hour)}$$

(c) Calculate Z by adding Z_r to Z_i by the following formula.

$$Z = Z_r + \frac{1}{2} \cdot Z_i = \frac{3600}{t_a + t_b} \cdot \left(nr + \frac{1}{2} ni \right) \text{ (times/hour)}$$

3. Calculate C x Z (the product of C and Z)

Use the value of C obtained in Step (1) and value of Z obtained in Step (2).

4. Obtain the duty cycle %ED and compare calculated C x Z in the appropriate column from Motor Thermal Rating Table.

$$\%ED = \frac{t_a}{t_a + t_b} \cdot 100$$

t_a = on-time
 t_b = off-time

Brakemotor Characteristics

The brakemotor on Cyclo® gearmotors operates with direct current supplied by a dual voltage rectifier for 230/460V, or single voltage rectifier/power module for other noted voltages. Rectifier or power module is mounted in the motor conduit box.

When used for outdoor installations, standard brakemotor must be protected by a cover. Such covers are available from the factory, please inquire when ordering.

Note: Advise the factory when ordering if you require brake torque greater or lesser than those shown as standard in the Brakemotor Characteristics table below.

Brake Characteristics

Table 5.27 Brake Characteristics - Standard torque, Delay Time, Work Capacity

Brake Model	Motor Capacity		Standard Braking Torque ft - lbs (N - m)	Braking Delay Time (sec)			Brake Work Capacity		
				Normal Braking Action		Fast Braking Action	Allowable E_0 (J/min)	Gap Adjust (x 10 ⁷ J)	Total E_1 (x 10 ⁷ J)
				Standard Wiring	Inverter Wiring ^[1]				
FB-3E	3	2.2	16 (22)	0.75 ~ 0.95	0.4 ~ 0.5	0.02 ~ 0.04	5720	26.3	105.3
FB-5E	5	3.7	30 (40)	1.1 ~ 1.3	0.4 ~ 0.5		6900	57.4	382.8
FB-8E	7.5	5.5	40 (55)	1.0 ~ 1.2	0.3 ~ 0.4		10800	110.2	551.1
FB-10E	10	7.5	59 (80)	1.8 ~ 2.0	0.6 ~ 0.7				
FB-15E	15	11	80 (110)	1.6 ~ 1.8	0.5 ~ 0.6				

Table 5.28 Brake Maintenance: Brake Gap, Lining Thickness

Brake Model	Brake Gap			Brake Lining Thickness	
	Spec. (Initial) inch (mm)	Limit inch (mm)	Adjustment Method	Spec. (Initial) inch (mm)	Limit inch (mm)
FB-3E		0.034 (0.85)	Nut	0.410 (10.4)	0.331 (8.4)
FB-5E	0.014 ~ 0.018 (0.35 ~ 0.45)	0.040 (1.0)		0.394 (10.0)	0.236 (6.0)
FB-8E		0.047 (1.2)		0.433 (11.0)	0.276 (7.0)
FB-10E					
FB-15E					

Brakemotor: Brake Current Rating - 60Hz

Table 5.29 Brake Current for EP.NA Motor

Brake Model	230VAC, 60Hz			240VAC, 60Hz			460VAC, 60Hz			480VAC, 60Hz		
	Vdc (V)	Idc (A)	Iac (A)	Vdc (V)	Idc (A)	Iac (A)	Vdc (V)	Idc (A)	Iac (A)	Vdc (V)	Idc (A)	Iac (A)
FB-3E	207VDC Full Wave	0.2	0.2	216VDC Full Wave	0.2	0.2	207VDC Half Wave	0.2	0.2	216VDC Half Wave	0.2	0.2
FB-5E		0.4	0.4		0.4	0.4		0.4	0.3			
FB-8E		0.4	0.4		0.4	0.3		0.3	0.3			
FB-10E		0.4	0.4		0.4	0.3		0.3	0.4			
FB-15E		0.4	0.4		0.4	0.3		0.4	0.4			

Table 5.29 continued... Brake Current for EP.NA Motor

Brake Model	575VAC, 60Hz		
	Vdc (V)	Idc (A)	Iac (A)
FB-3E	259VDC Half Wave	0.2	0.2
FB-5E		0.4	0.3
FB-8E		0.4	0.3
FB-10E		0.5	0.4

Note: Brake coil design will be specific to brake voltage specified at time of order. Check motor nameplate, to determine brake voltage rating.

Brakemotor: Brake Current Rating - 50 Hz

Table 5.30 Brake Current for IE3 CE Motor

Brake Model	220VAC, 50/60Hz			230VAC, 50/60Hz			380VAC, 50/60Hz			400VAC, 50/60Hz		
	Vdc (V)	Idc (A)	Iac (A)	Vdc (V)	Idc (A)	Iac (A)	Vdc (V)	Idc (A)	Iac (A)	Vdc (V)	Idc (A)	Iac (A)
FB-3E	99VDC HalfWave	0.6	0.5	104VDC HalfWave	0.6	0.5	171VDC HalfWave	0.3	0.2	180VDC HalfWave	0.3	0.2
FB-4E												
FB-5E		1	0.7		1	0.8		0.4	0.3		0.4	0.3
FB-8E		1	0.7		1	0.8		0.4	0.3		0.4	0.3
FB-10E		1.1	0.9		1.2	0.9		0.5	0.4		0.5	0.4

Notes: Brake coil design will be specific to brake voltage specified at time of order. Check motor nameplate, to determine brake voltage rating.

Brakemotor: Optional Brake Torques

Table 5.31 Brake Torques: Standard and Inverter

Brake Model	Motor Capacity			Braking Torque ft-lbs (N-m)				
	Model	HP x 4P (ST)	HP x 4P (AV)	kW x 4P (ST)	Standard	Optional		
FB-3E	3	2	2.2	16 (22)	4.4 (6.0)	7.4 (10)	11 (15)	22 (30)
FB-5E	5	3	3.7	30 (40)	7.4 (10)	15 (20)	22 (30)	40 (55)
FB-8E	7.5	5	5.5	40 (55)	15 (20)	22 (30)	30 (40)	53 (72)
FB-10E	10	7.5	7.5	59 (80)	15 (20)	30 (40)	44 (66)	80 (110)
FB-15E	15	10	11	80 (110)	29 (40)	44 (60)	59 (80)	110 (150)

ST - Standard Motor, AV - Inverter Motor

Brakemotor Standard Wiring Connection

Models FB-3E through FB-15E, 230/460V, 60Hz or 575V, 60Hz

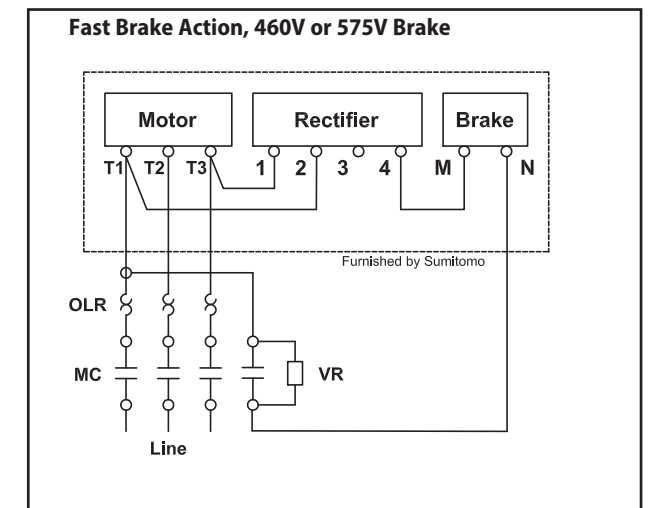
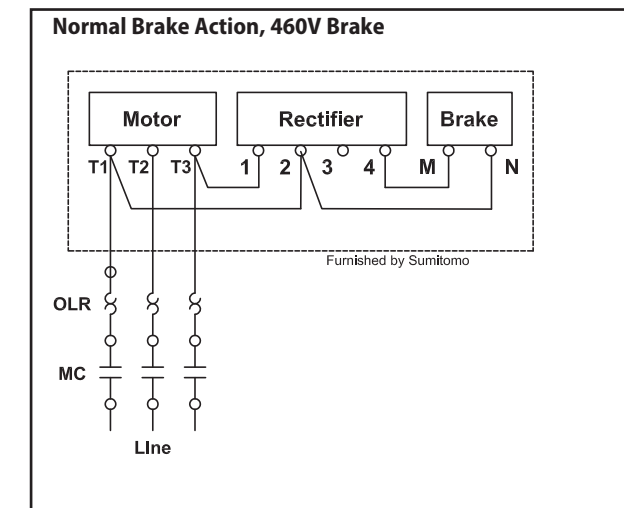
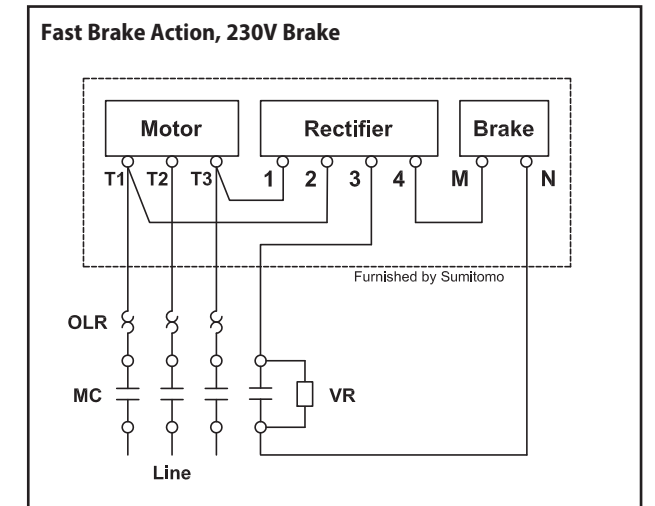
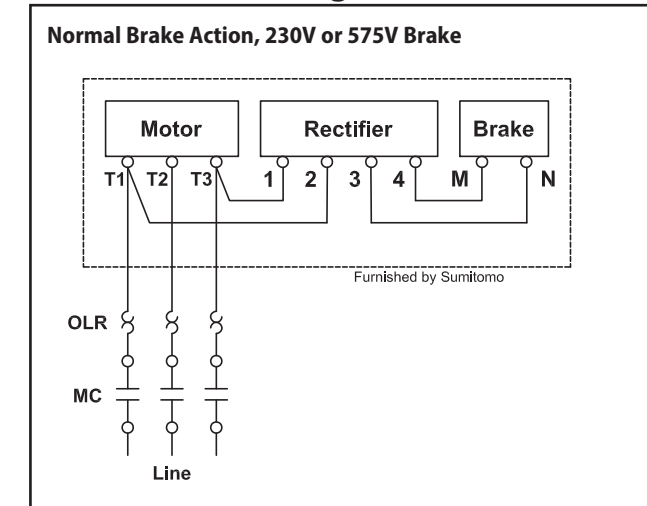

Key:
MC: Motor Contactor
OLR: Overload or Thermal Relay
VR: Varistor (protective device, refer to Varistor Specification Table)

Brakemotor Standard Wiring Connection

Table 5.32 Varistor Specification Table

Operating Voltage		190-230V	380-460V	575V
Varistor Rated Voltage		AC260-300V	AC510V	AC604V
Varistor Voltage		430-470V	820V	1000V
Rated Watt	FB-1E, 1D	Over 0.6W	Over 0.6W	Over 0.4W
	FB-1HE, 2E, 2D, 3E	Over 1.5W	Over 1.5W	Over 0.6W
	FB-5E, 8E, 10E, 15E	Over 1.5W	Over 1.5W	Over 1.5W

Brakemotor Inverter Wiring Connection

Models FB-3E through FB-15E, 230/460V, 60Hz or 575V, 60Hz

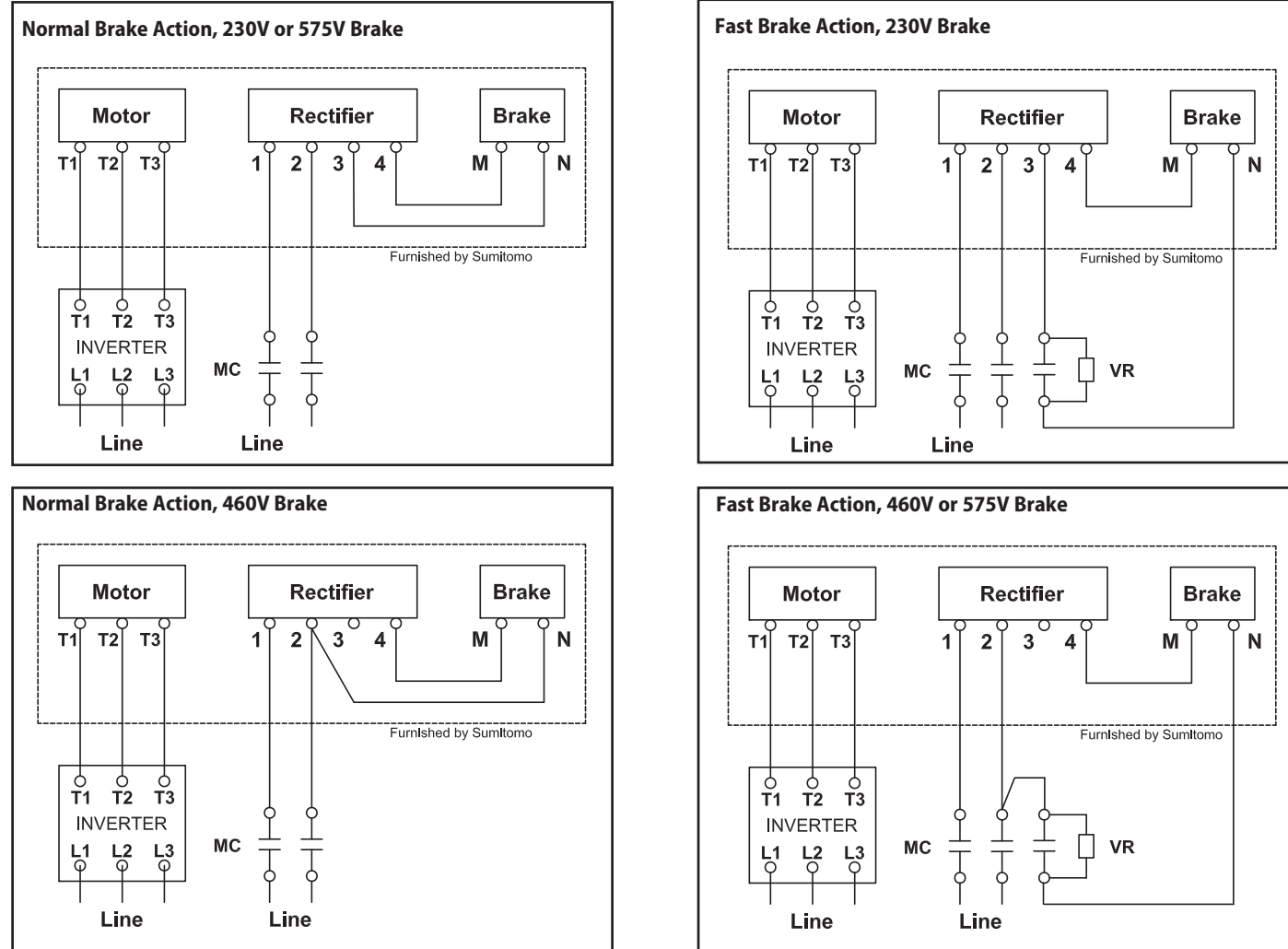

Key:
MC: Motor Contactor
OLR: Overload or Thermal Relay
VR: Varistor (protective device, refer to Varistor Specification Table)

Brakemotor Inverter Wiring Connection

Table 5.33 Varistor Specification Table

Operating Voltage		190-230V	380-460V	575V
Varistor Rated Voltage		AC260-300V	AC510V	AC604V
Varistor Voltage		430-470V	820V	1000V
Rated Watt	FB-1E, 1D	Over 0.6W	Over 0.6W	Over 0.4W
	FB-1HE, 2E, 2D, 3E	Over 1.5W	Over 1.5W	Over 0.6W
	FB-5E, 8E, 10E, 15E	Over 1.5W	Over 1.5W	Over 1.5W

Brakemotor Standard Wiring Connection for CE Motors

Models FB-3E through FB-5E, 220/380V, 50Hz (see page 5.39 for wiring with inverter)

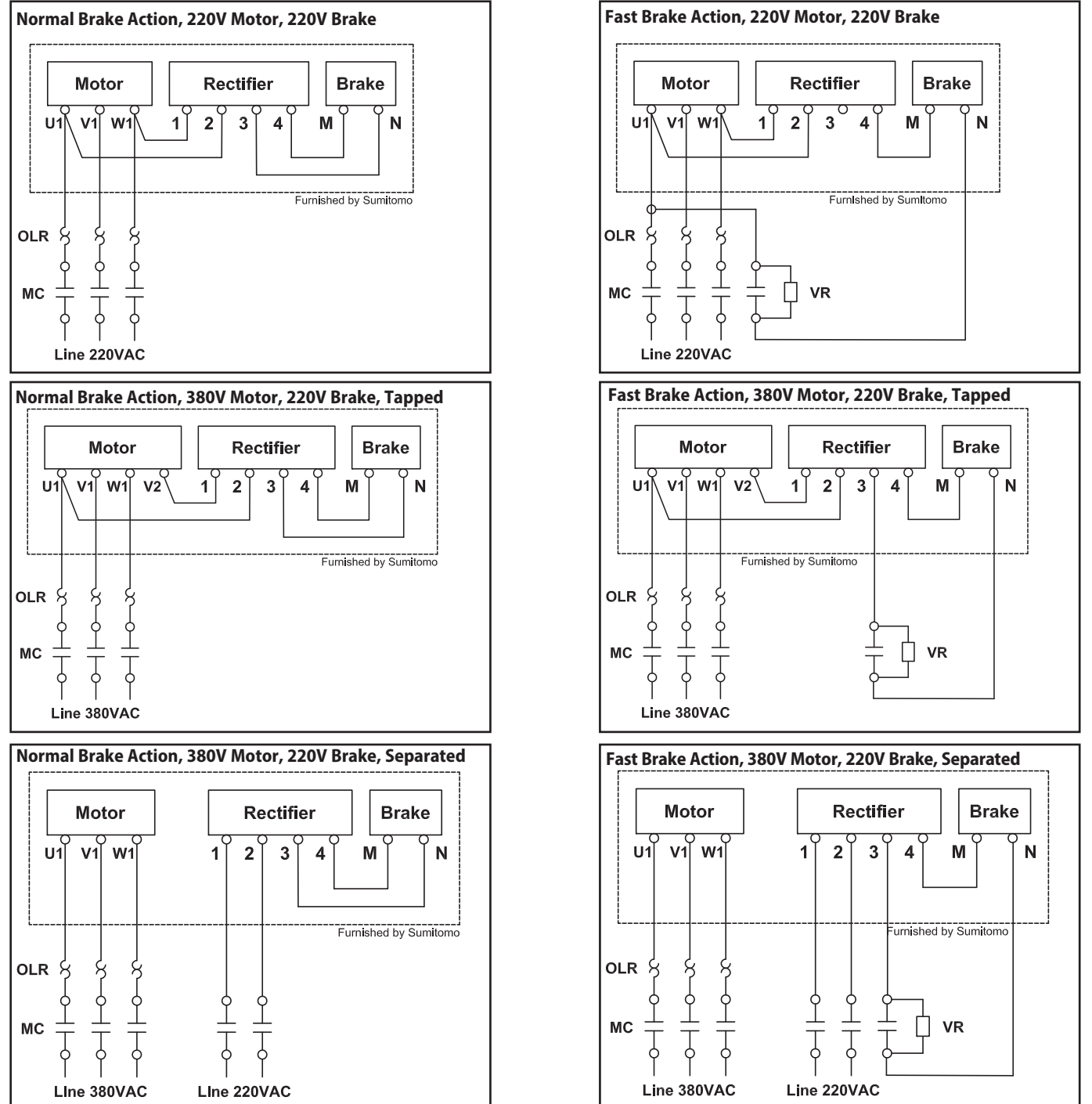

Key:
MC: Motor Contactor
OLR: Overload or Thermal Relay
MCB: Magnetic Circuit Breaker
VR: Varistor (protective device, refer to Varistor Specification Table on page 5.39)

Brakemotor Standard Wiring Connection for CE Motors (continued)

Models FB-8E through FB-15E, 380V, 50Hz

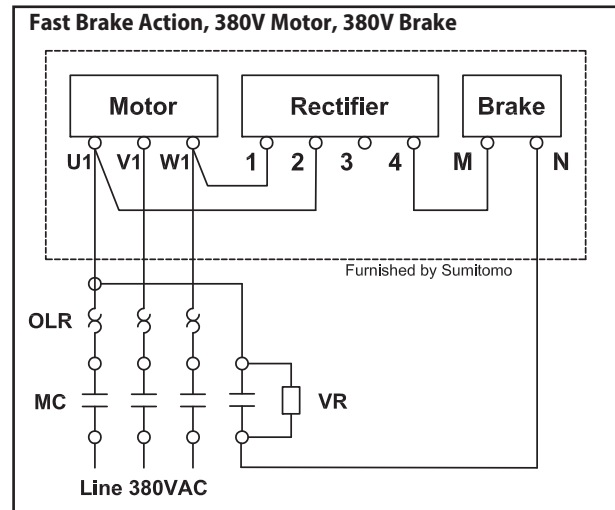
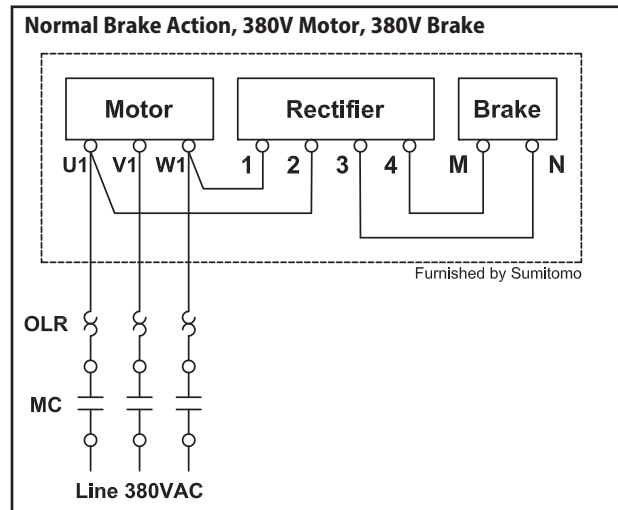

Models FB-3E. through FB-15E with Inverter 220/380V, 50Hz

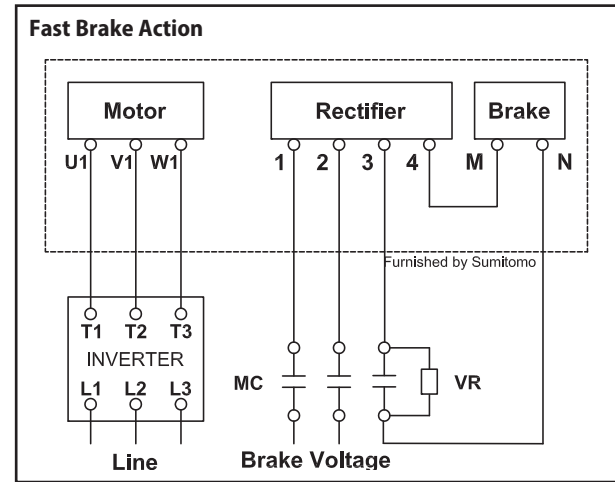
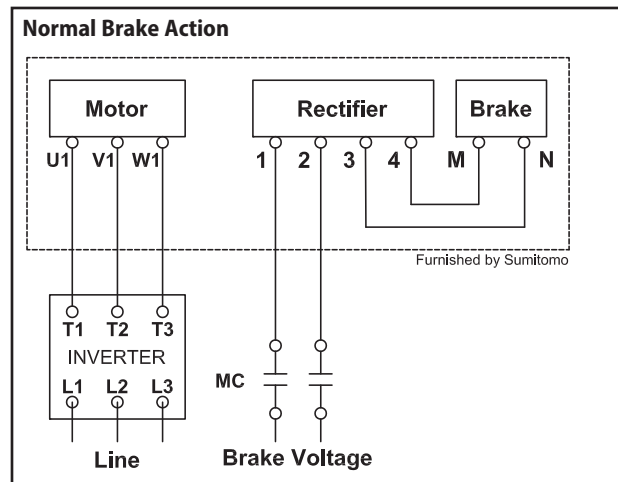

Key: MC: Motor Contactor OLR: Overload or Thermal Relay VR: Varistor (protective device, refer to Varistor Specification Table)

Table 5.34a CE Motor, Motor/Brake Voltage Table

Motor Power kW x 4P	Brake Model	Motor Voltage	Brake Voltage
2.2	FB-3E	220/380V, 50Hz	220V, 50Hz*
3.7	FB-5E		
5.5	FB-8E	380V, 50Hz	380V, 50Hz
7.5	FB-10E		
11	FB-15E		

Table 5.34b Varistor Specification Table

Operating Voltage	220V	380V	
Varistor Rated Voltage	AC300V	AC510V	
Varistor Voltage	470V	820V	
Rated Watt	FB-3E	Over 1.5W	Over 1.5W
	FB-5E, 8E	Over 1.5W	Over 1.5W
	FB-10E, 8E	Over 1.5W	Over 1.5W

*optional 380V 50Hz Brake Available

Brake Rectifiers and Brake Power Modules

Table 5.35a Brake Rectifiers for EP.NA Motors

Brake Type	Motor Power HP x P	230V/460V Rectifier		575V Rectifier	
		Model Number	Part Number	Model Number	Part Number
FB-3E	3 x 4	25FW-4FB3	EY477WW-01	10F-6FB3	EY498WW-01
FB-5E	5 x 4				
FB-8E	7.5 x 4				
FB-10E	10 x 4				
FB-15E	15 x 4				

Table 5.35b Brake Rectifiers for IE3 CE Motors

Brake Type	Motor Power kW x P	220V Rectifier		380V Rectifier	
		Model Number	Part Number	Model Number	Part Number
FB-3E	2.2 x 4	10F-2FB2	MP983WW-01		
FB-5E	3.7 x 4 4.0 x 4				
FB-8E	5.5 x 4			05F-4FB2	MP985WW-01
FB-10E	7.5 x 4			15F-4FB1	EW397WW-01
FB-15E	11 x 4				

Technical Information

Technical Information

Warranty

Company warrants that (i) all new equipment and parts (collectively, “Equipment”) sold by Company will conform to printed drawings and specification sheets issued by Company and (ii) are free of defects in material and workmanship for the time period shown in Table 5.36. The warranty period commences on the date of shipment of the Equipment by Company.

If, within the warranty period, Company receives from Buyer written notice of any alleged defect in any of the Equipment and, if the Equipment is found by Company not to conform with these warranties (after Buyer has provided Company a reasonable opportunity to perform any appropriate tests on the allegedly defective Equipment), Company will, at its sole option and expense, either repair or replace the Equipment. In all instances, Company reserves the right to require Buyer to deliver the Equipment for repair or replacement to a designated service center and require Buyer to pay all charges for inbound and outbound transportation and for services of any kind, diagnostic or otherwise, excepting only the direct and actual cost of Equipment repair or replacement. Warranty coverage is limited to parts and labor and does not include travel and other expenses. Buyer applications and use of the Equipment may require installation of safety features. Buyer is responsible for furnishing and installing guards or other safety equipment needed to protect operating personnel, even though such equipment may not be furnished by Company with the Equipment purchased. Equipment supplied, but not manufactured, by Company is warranted only to the extent of the original manufacturer’s warranty.

Table 5.36 - Product Warranty

Product	Warranty Period (After Shipment)	Components Excluded
Cyclo® Speed Reducers and Gearmotors	3 Years	Wearable items
Cyclo® Bevel & Helical BuddyBox® Speed Reducers and Gearmotors	3 Years	Wearable items
Fine Cyclo® and Elastic Cyclo (ECY) Speed Reducers	2 Years	Wearable items
Beier® Variator Mechanical Adjustable Speed Reducers	2 Years	Wearable items
Hyponic® Speed Reducers and Gearmotors	3 Years	Wearable items
Helical Shaft Mount Speed Reducers	3 Years	Wearable items
Bevel BuddyBox® H Series Speed Reducers and Gearmotors	3 Years	Wearable items
Fortress® Speed Reducers	3 Years	Wearable items
Rhytax® Speed Reducers and Gearmotors	3 Years	Wearable items
IB Series Servo Gearheads & Astero Gearmotors	1 Year	Wearable items
Motors	1 Year	-
Variable Frequency Drives (Invertek)	3 Years	-
Hedcon® Double Enveloping Worm Gear Speed Reducers	2 Years	Wearable items
Paramax® Right Angle Spiral Bevel Gear and Parallel Shaft Helical Gear Speed Reducers	2 Years	Wearable items
Hansen UniMiner and P4 Right Angle Spiral Bevel Gear and Parallel Shaft Helical Gear Speed Reducers	2 Years	Wearable items
Paramax® and Hansen Cooling Tower Application Series Speed Reducers	1 Year	Wearable items
Compower® Planetary Speed Reducers	1 Year	Wearable items
Parts	1 Year	-
Repairs	1 Year	Wearable items

BBB-H

Technical Information