

Taper Grip® Bushing Installation Guide

Introduction

The keyless Taper-Grip® bushing system provides simple and reliable shaft attachment for Sumitomo Speed reducers and gearmotors. This system allows bi-directional shaft rotation and stop-start operation with a powerful, slip-free grip. To assure peak performance of your equipment, please read, understand and follow these installation instructions.

Safety

Disconnect all power sources from the equipment before beginning this installation procedure. Handle the components with care and avoid all sharp or machined edges to prevent personal injury or damage to the components.

Before Installing Unit on Driven Shaft (Steps 1-7)

Carefully inspect the driven equipment shaft. Remove all burrs, corrosion, lubricants, and foreign matter from the shaft surface. Verify the shaft diameter is within the dimensional tolerances shown in Table 1.

Table 1 Driven Shaft Tolerances

Shaft Diameter (inches)	Shaft Tolerance (inches)
3/4" – 1-1/8"	+0" – 0.0013"
1-3/16" – 2"	+0" – 0.0015"
2-1/16" – 3-1/8"	+0" – 0.0018"
3-3/16" – 4-3/4"	+0" – 0.0021"
4-13/16" – 6-1/2"	+0" – 0.0025"

Clean all surfaces of the shaft, the bushing, the thrust collar and the unit bore with solvent to remove all grease and oil.

Step 1 – Remove the Taper-Grip® bushing safety cover (see Fig. 2).

Step 2 – Remove the cap screws from the bushing. Lightly oil the threads of the cap screws and partially re-insert them into the threaded holes in the bushing flange. The ends of the cap screws should not extend beyond the rear face of the bushing flange.

Step 3 – Slide the thrust collar onto the Taper-Grip® bushing (see Fig. 3).

Step 4 – Apply a thin layer of anti-seize paste **to the male threads of the Taper-Grip® Bushing only** (see Fig.4). Based on tests, Sumitomo recommends Bostik Never-Seez Regular Grade or equivalent. Ensure that anti-seize paste does not enter the Taper-Grip® Bushing bore.

Caution: Do not apply anti-seize paste to the female threads in the hub.

Step 5 – Carefully thread the Taper-Grip® bushing (TGB) in casing side or Extended Taper-Grip® bushing (TGB XL) in cover side into the hub of the speed reducer or gearmotor until the thrust collar solidly engages the unit hub surface and the bushing flange (see Fig. 5). **Caution: Do not cross-thread. Bushing should thread easily into hub.**

Step 6 – Unscrew the Taper-Grip® bushing to create a 1mm (0.04") gap between the thrust collar and the bushing flange.

Step 7 – Hand-tighten the cap screws until they firmly press the thrust collar against the unit hub surface. The unit is ready for installation on the driven shaft.

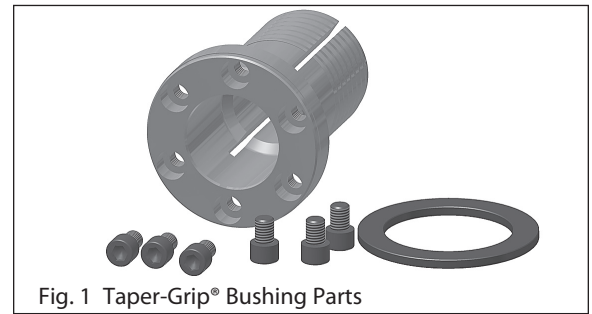

Fig. 1 Taper-Grip® Bushing Parts

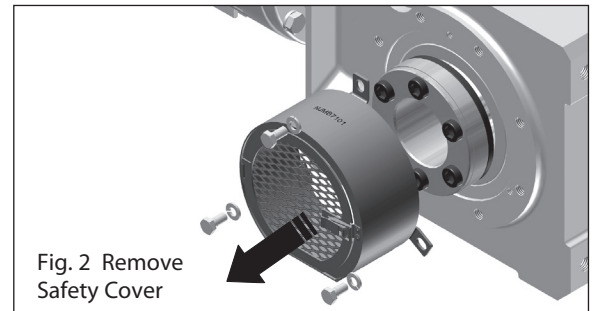

Fig. 2 Remove Safety Cover

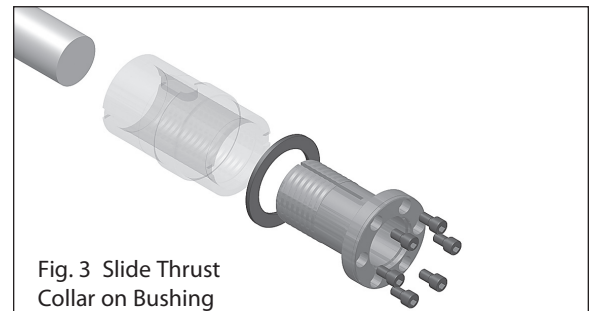

Fig. 3 Slide Thrust Collar on Bushing

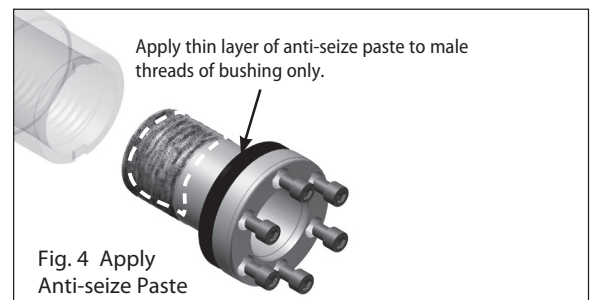

Fig. 4 Apply Anti-seize Paste

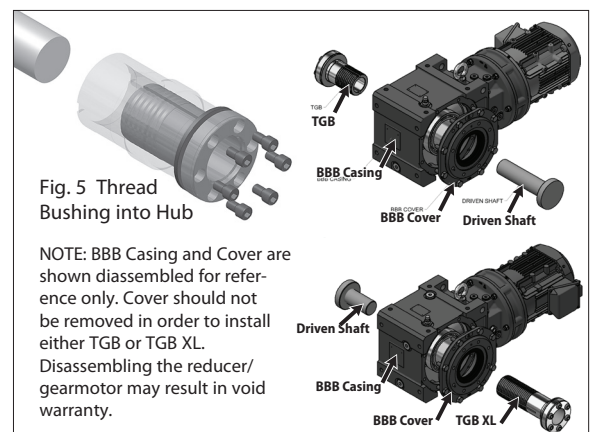

Fig. 5 Thread Bushing into Hub

NOTE: BBB Casing and Cover are shown disassembled for reference only. Cover should not be removed in order to install either TGB or TGB XL. Disassembling the reducer/gearmotor may result in void warranty.

Taper Grip® Bushing Installation Guide continued

Unit Installation

Step 8 – Position unit with the bushing flange located on the outboard side of the unit. Align the bushing with the driven shaft. Slide the unit onto the driven shaft as close to the driven shaft support bearing as possible. Ideally, the driven shaft should extend beyond the bushing flange face (see Fig. 7). Refer to Fig. 6 and Table 2 below for minimum shaft to bushing engagement. For maximum depth to the end of the shaft, refer to Fig. 6 and Table 3 below.

Table 2 Minimum Shaft to Bushing Engagement

HSM Model	Minimum Shaft Engagement										
	Cyclo® HBB		Cyclo® BBB4 (TGB)		Cyclo® BBB4 (TGB XL)						
mm	in.	Model	mm	in.	Model	mm	in.	Model	mm	in.	
107C	119.5	4.70	Z	113.5	4.47						
115D	127.5	5.02									
203E	136	5.35	A	127	5.00	A	209	8.23	A	110	4.33
207F	153	6.02	B	144	5.67	B	243	9.57	B	120	4.72
215G	183	7.20	C	187	7.36	C	280	11.02	C	150	5.91
307H	205	8.07	D	205	8.07	D	327	12.87	D	170	6.69
315J	215	8.46	E	225	8.86	E	360	14.17	E	190	7.48
407S	219	8.62				F	412	16.22	F	227	8.94
415K	217	8.54									
507L	285	11.22									
608M	335	13.19									

Table 3 Maximum Depth to Shaft End

HSM Model	Maximum Depth to Shaft End										
	Cyclo® HBB		Cyclo® BBB4		Cyclo® BBB4 (TGB XL)						
mm	in.	Model	mm	in.	Model	mm	in.	Model	mm	in.	
107C	31	1.22	Z	31	1.22						
115D	34	1.34									
203E	35	1.38	A	35	1.38	A	35	1.38	A	134	5.28
207F	45	1.77	B	45	1.77	B	45	1.77	B	168	6.61
215G	40	1.57	C	40	1.57	C	40	1.57	C	170	6.69
307H	50	1.97	D	50	1.97	D	50	1.97	D	207	8.15
315J	51	2.01	E	51	2.01	E	51	2.01	E	221	8.70
407S	63	2.48				F	74	2.93	F	253	9.96
415K	70	2.76									
507L	70	2.76									
608M	70	2.76									

Step 9 – With a torque wrench, tighten the cap screws in 20% increments to engage the bushing system. Use the appropriate tightening pattern (“star-pattern” see Fig. 7) to assure complete bushing engagement. Tighten each cap screw to the torque values shown in Table 4.

If the shaft is recessed in the bushing, fill the void with grease to prevent corrosion and fouling.

Step 10 – Please read, understand and follow the instructions shown in the reducer/gearmotor installation and operating manual to complete the unit installation and attach the torque arm.

Step 11 – After the reducer has been running for 20 to 30 hours, re-torque the screws to the values in Table 4. Screw torques should be subsequently checked at normal service intervals (i.e. every 6 months).

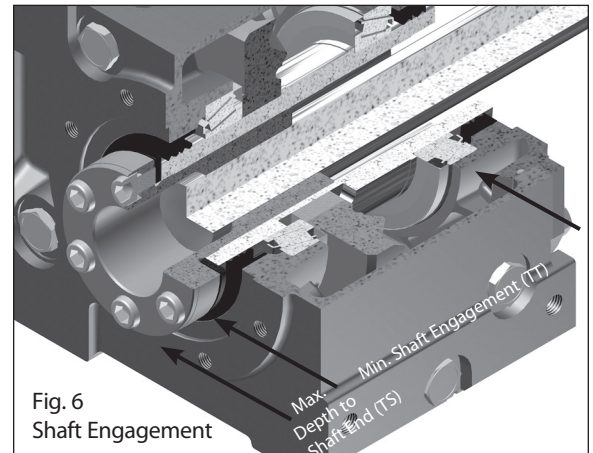

Fig. 6 Shaft Engagement

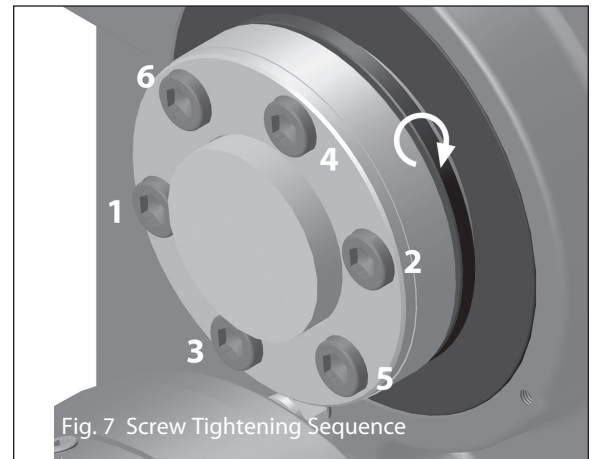

Fig. 7 Screw Tightening Sequence

Table 4 Cap Screw Tightening Torques

HSM Model	Cyclo® BBB4 Model	Cap screws (JIS Grade 12.9)		Cap screw Torque	
		Qty.	Size	Nm	Lb.Ft.
107C		6	M10x14	50	37
115D		6	M10x14	55	41
203E	A	6	M12x16	75	56
207F	B	6	M12x16	140	104
215G	C	6	M16x20	250	185
307H	D	6	M16x20	300	223
315J	E	8	M16x20	300	223
407S	F	10	M16x20	300	223
415K		10	M16x35	300	223
507L		12	M16x35	300	223
608M		16	M16x35	300	223

Cyclo® HBB Model	Cap screws (JIS Grade 12.9)		Cap screw Torque	
	Qty.	Size	Nm	Lb.Ft.
Z	6	M10x14	31	23
A	6	M12x16	51	37.5
B	6	M12x16	51	37.5
C	6	M16x20	128	95
D	6	M16x20	200	148
E	8	M16x20	200	148

Taper Grip® Bushing Installation Guide continued

Removal Procedure

Step 1 – Remove the Taper-Grip® bushing safety cover (see Fig. 8).

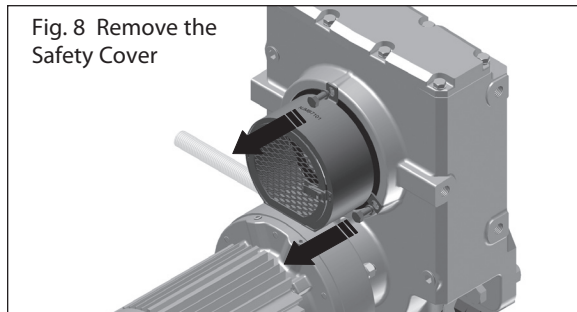

Step 2 – Before removing the reducer/gearmotor from the driven shaft, externally support the unit so that all its weight is removed from the driven shaft (see Fig. 9). **Caution: Do not raise the unit too high. It may cause the shaft to bind.**

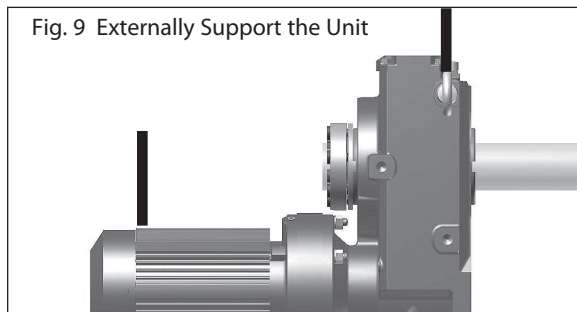

Step 3 – Check the Taper-Grip® Bushing to assure that there is a gap between the thrust collar and the bushing flange. If no gap exists, unit removal may be difficult (see Fig. 10).

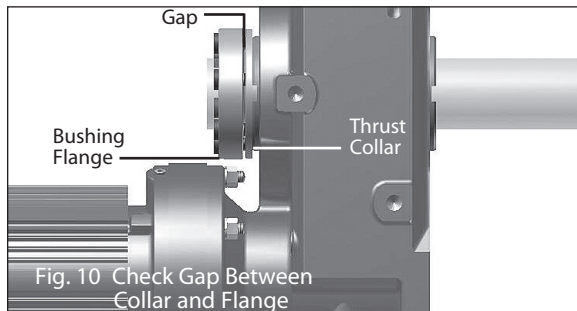

Step 4 – Spray a liquid penetrant onto each of the Taper-Grip® Bushing cap screws. Allow time for the penetrant to settle into the threads of the cap screws. (see Fig. 11).

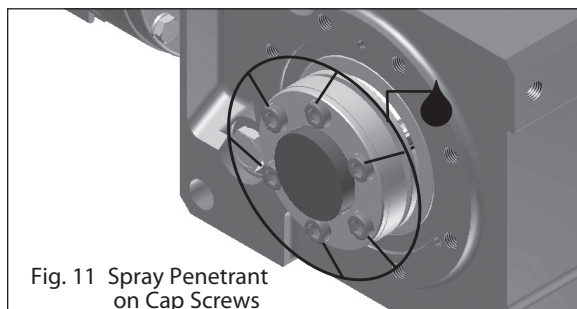

Step 5 – After the liquid penetrant has been allowed to settle, remove the cap screws one at a time (see Fig 12).

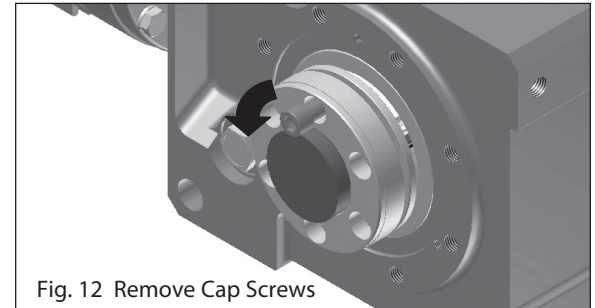

Step 6 – Place a copper or brass bar against the flange of the Taper-Grip® Bushing and carefully strike end of bar with a hammer to release bushing (see Fig 13).

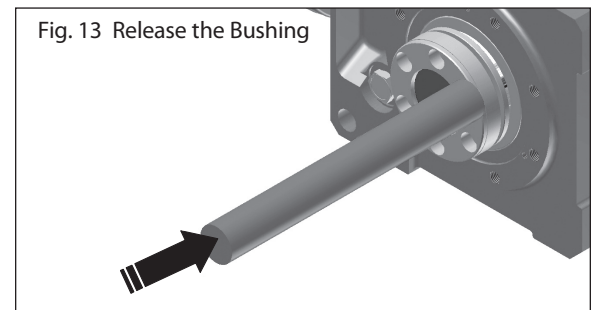

Step 7 – After releasing the bushing, reinstall the cap screws by hand only. Stop tightening them once they touch the thrust collar. They will ensure the reducer will not slide against the bushing and clamp it against the shaft when the reducer is removed. Apply a liquid penetrant to the shaft where it contacts the bushing. Allow time for the liquid to penetrate between the bushing and the shaft, then carefully slide the unit off of the shaft. (see Fig 14). **Note: If the bushing releases, but the unit cannot be removed from the shaft, apply a puller to the bushing to push the shaft free.**

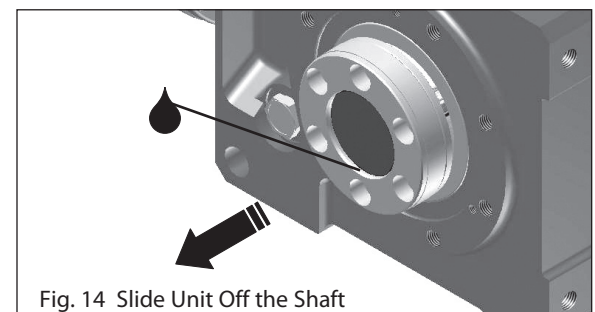

Sumitomo Machinery Corporation of America

Headquarters & Manufacturing

4200 Holland Boulevard
Chesapeake, VA 23323
Tel: 757-485-3355 • Fax: 757-485-7490

www.sumitomodrive.com
E-mail: customercare@suminet.com



www.sumitomodrive.com

World Headquarters

Japan
Sumitomo Heavy Industries, Ltd.
Power Transmission & Controls Group
ThinkPark Tower, 1-1, Osaki 2-chome,
Shinagawa-ku, Tokyo 141-6025 Japan
Tel: +81-36-737-2511 • Fax: +81-36-866-5160

*For worldwide locations, please visit
www.sumitomodrive.com/worldwide*