

Sumitomo Drive Technologies

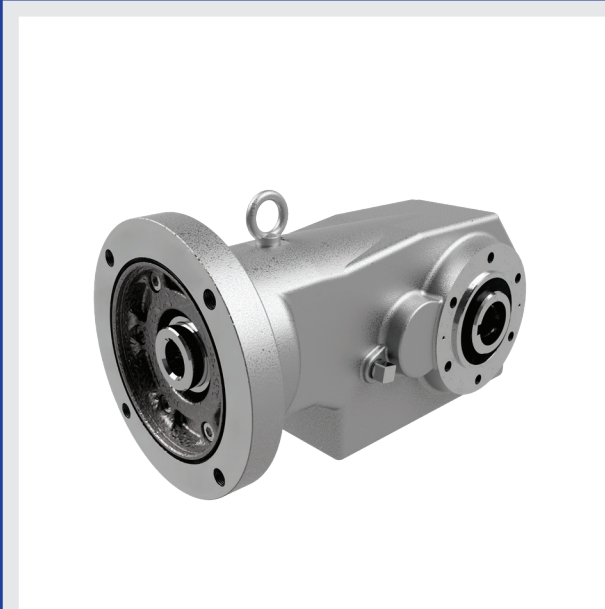

FORTRESS[®]
S T A I N L E S S S T E E L

Table of Contents

1. General Information

2. Fortress®

- FAQs.....6
- Standard Specifications.....7
- How To Select.....8
- Configure A Model Number 10
- Nomenclature11
- AGMA Load Classification12
- Selection Tables14
- Dimensions.....15

3. Options

- Flange.....16
- Foot.....16
- Torque Arm.....17
- Shrink Disc.....18
- Shaft Availability.....19

4. Technical Information

- Shaft Rotation20
- Actual Reduction Ratio.....20
- Special Load Guidelines: Overhung Load21
- Special Load Guidelines: Inertia22
- Mounting.....22
- Accessories22
- Lubrication23
- Warranty..... 24

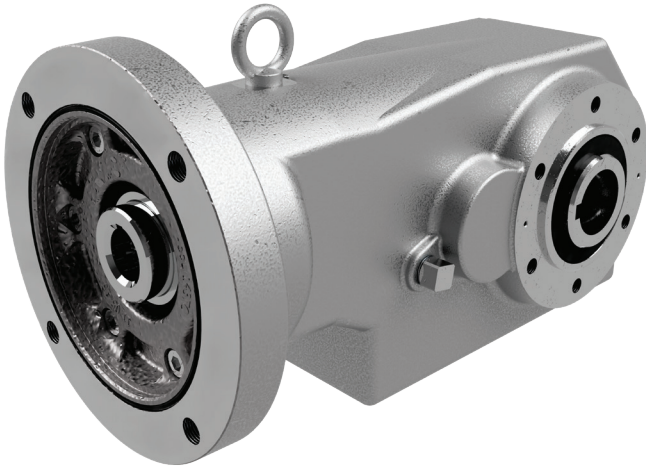

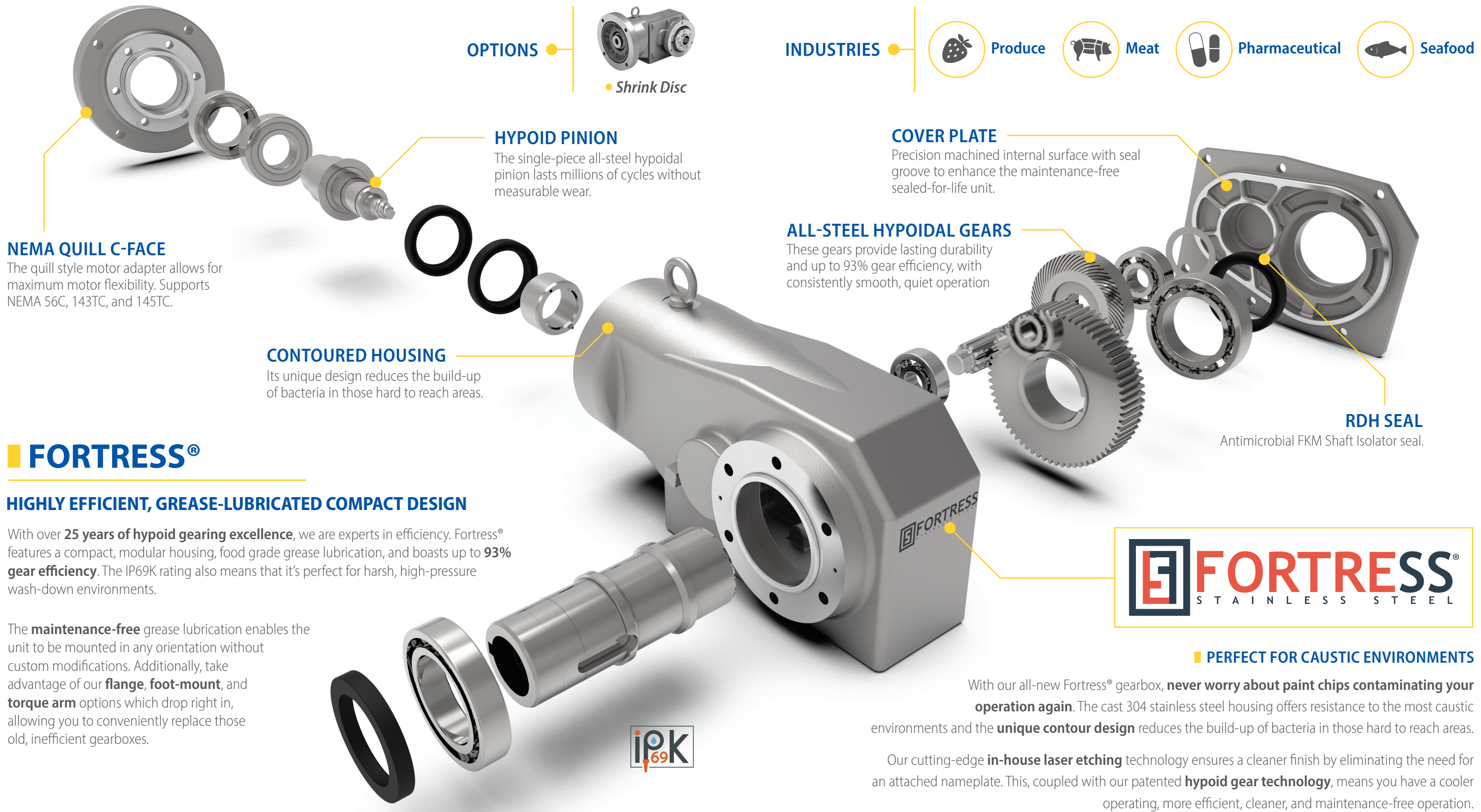

OPTIONS

- Shrink Disc

INDUSTRIES

- Produce
- Meat
- Pharmaceutical
- Seafood

NEMA QUILL C-FACE
The quill style motor adapter allows for maximum motor flexibility. Supports NEMA 56C, 143TC, and 145TC.

HYPOID PINION
The single-piece all-steel hypoidal pinion lasts millions of cycles without measurable wear.

COVER PLATE
Precision machined internal surface with seal groove to enhance the maintenance-free sealed-for-life unit.

ALL-STEEL HYPOIDAL GEARS
These gears provide lasting durability and up to 93% gear efficiency, with consistently smooth, quiet operation

CONTOURED HOUSING
Its unique design reduces the build-up of bacteria in those hard to reach areas.

RDH SEAL
Antimicrobial FKM Shaft Isolator seal.

FORTRESS®

HIGHLY EFFICIENT, GREASE-LUBRICATED COMPACT DESIGN

With over **25 years of hypoid gearing excellence**, we are experts in efficiency. Fortress® features a compact, modular housing, food grade grease lubrication, and boasts up to **93% gear efficiency**. The IP69K rating also means that it's perfect for harsh, high-pressure wash-down environments.

The **maintenance-free** grease lubrication enables the unit to be mounted in any orientation without custom modifications. Additionally, take advantage of our **flange, foot-mount, and torque arm** options which drop right in, allowing you to conveniently replace those old, inefficient gearboxes.



PERFECT FOR CAUSTIC ENVIRONMENTS

With our all-new Fortress® gearbox, **never worry about paint chips contaminating your operation again**. The cast 304 stainless steel housing offers resistance to the most caustic environments and the **unique contour design** reduces the build-up of bacteria in those hard to reach areas.

Our cutting-edge **in-house laser etching** technology ensures a cleaner finish by eliminating the need for an attached nameplate. This, coupled with our patented **hypoid gear technology**, means you have a cooler operating, more efficient, cleaner, and maintenance-free operation.

SPECS

- **HP RATING**
1/2 HP to 2 HP (1.72 kW)

- **DIAMETER**
3/4in to 1-7/16in

- **TORQUE**
Up to 2,190 lb-in (247 N·m)

- **RATIO RANGE**
7:1 up to 60:1

MOUNTING

- Flange Mount
- Foot Mount
- Shaft Mount

How do I select a Fortress® Reducer?

Selection is based on the actual horsepower and/or application torque requirement. Fortress® speed reducer has particularly high efficiencies (Up to 93% gear efficiencies) over a wide range of reduction ratios, which frequently permits the use of reduced input power requirements (smaller Hp) without sacrificing output shaft torque.

What information do I need to get started in the selection process?

- Application: Type of Driven Machine
- Hours of operations per day (Duty Cycle)
- Loading Conditions (Intermittent, Continuous, Ambient Temperature, etc..)
- Mounting Accessories (Base, Torque Arm, Flange, Customer supplied Design)

What type and Grade of material is Fortress® made from?

The Fortress® reducer is made of Austenitic-Ferrite CF8 (AISI 304) alloy grade of cast stainless steel. CF8 combines superior corrosion resistance along with high material strength and wear resistance, making it the ideal material for dairy equipment and a wide variety of food applications.

What is Austenitic-Ferrite Stainless Steel?

CF (Austenitic-ferrite) cast steel material is composed of low carbon and higher chromium content. This chemical composition gives an excellent corrosion resistance property in aqueous environments. CF grade family is preferred in chemical, pharmaceutical and food industries.

Which Chemicals can the Fortress® Unit be exposed to?

CF8/ AISI 304 has a wide array and varying levels of corrosion resistance. In general Fortress® corrosion resistance level will comply with the standard level of resistance for any commercially available AISI 304 grade material.

What is the surface finish of the Fortress® Unit?

The Fortress® unit is produced using an Investment "Lost Wax" casting process, which provides the smoothest cast surface. The end result of the process is a surface finish that ranges from 60 to 85 µin.

What is the Fortress® Rated Ingress Protection Level?

Fortress® is IP69K rated. The Fortress® unit is suitable to withstand high temperature steam as well as high-pressure water.

What are the motor options for Fortress®?

Fortress® is offered exclusively as a gear reducer. The unit is designed as NEMA Quill C-Face, which can be supplied with a stainless steel NEMA Electric Motor.

What are the routine Maintenance procedures for Fortress®?

Fortress® is completely maintenance free and lubricated for the life of the reducer. It can be mounted in any orientation without prior notification during the point of order.

What are the best cleaning procedure(s) for Fortress®?

- It is recommended that the unit is cleaned with a diluted acid solution such as; Nitric Acid, Hydrochloric Acid, Hydrofluoric acid, etc... The unit can also be wiped off with clean water or alkaline based soapy water. A commercially available passivated liquid should be routinely applied to help maintain the resilient color as well as maintain optimal corrosion resistance.
- **DO NOT** scrub the unit with steel ball or steel bristled brush that can scratch the unit surface. Doing so will damage the high chromium oxide film on the surface.

Materials	Reduction	Hardened steel gears, with hypoid input gearset and involute output gear set
	Lubrication	Grease lubricated; filled with H1 food grade synthetic grease prior to shipment
	Seals	FKM antimicrobial food grade seals
	Casings	AISI 304 Stainless Steel
	Bearings	Deep groove ball bearings on input and output
Ambient Conditions	Installation Location	Suitable for all non-submersible
	Ambient Temperature	14° ~ 104° F (-10° ~ 40° C)
	Atmosphere	Well ventilated location, free of explosive gases or vapors
	Elevation	Under 3300 feet (1000 meters)
	Ingress Protection	IP69K

Shaft Rotation

The direction of shaft rotation on the reducers varies according to frame size and ratio. Please refer to page 20 for specific data on the shaft rotation of various models.

Input Speeds

The selection tables in this catalog are based on 1750 RPM.

Thermal Capacity

Fortress®, by virtue of its smooth, almost frictionless operation (unlike traditional worm gears), has a thermal rating that exceeds its mechanical capacity.

How to select

- Step 1: Collect data about your application
Before starting you need to know the:
- Application (e.g. Conveyor, Mixer, etc.)
 - Hours of Operation per day
 - Motor Horsepower (HP) and Speed (RPM)
 - Desired Output Speed
 - Mounting Position and Style
 - Overhung or Thrust Loads
 - Bore Dimensions, inch or metric
 - Ambient Conditions

- Step 2: Select a Frame Size
2A: Find the Load Classification of your application in the AGMA Load Classification Table on page 12.
2B: Find the recommended Service Factor using the Recommended Reducer Service Factor Table or Recommended Service Factors for Frequent Start-Stop Applications Table on the right.
2C: Determine the Selection Horsepower by multiplying the Motor Horsepower by the Service Factor.
2D: Select a Frame size from the Reducer Selection Tables on page 14 by matching both the Selection Horsepower and Desired Output Speed (RPMs) to a frame size model number.

- Step 3: Verify Dimensions
Use the Dimensions information on page 15 to verify that the selected Frame Size is appropriate.

- Step 4: Choose Options
The following options may apply:
Solid Shaft
Mounting Feet
Output Flange
Torque Arm Assembly
Washdown Modification
Please see the Fortress® pricelist for available modifications, and refer to ages 16 - 18 of this catalog for dimension drawings of selected popular options .

- Step 5: Configure a Model Number
Go to page 10 to configure a model number.
Note: You will use the information you gather from the procedure on this page to Configure a Model Number.
For additional options, please visit our configurator at: www.sumitomodrive.com/configurator

Recommended Reducer Service Factors

	AGMA Load Classifications		
	Uniform (U)	Moderate Shock (M)	Heavy Shock (H)
1/2 hr. per day (Occasional)	0.50 ^[1]	0.80 ^[1]	1.25
3 hrs. per day (Intermittent)	0.80	1.00	1.50
Up to 10 hrs. per day	1.00	1.25	1.75
24 hrs. per day	1.20	1.50	2.00

Note: [1] Maximum momentary or starting load must not exceed 300% of gear reducer rating (rating meaning service factor of 1.0). Time specified for occasional and intermittent service refers to total operating time per day.

Recommended Service Factors for Frequent Start-Stop Applications
For frequent start-stop applications, use the table below to determine the recommended service factor.

Number of starts (Times/hour)	~10 hours/day			~24 hours/day		
	I	II	III	I	II	III
~10	1.00	1.15	1.50	1.20	1.30	1.65
~200	1.10	1.35	1.65	1.30	1.50	1.85
~500	1.15	1.50	1.80	1.40	1.65	2.00

The Moment of Inertia (ratio of Inertia WR^2) = $\frac{\text{Total Moment of Inertia (WR}^2\text{) as seen from motor shaft}}{\text{Moment of Inertia (WR}^2\text{) of motor}}$

- I = Allowable ratio of Moment of Inertia (WR^2) ≤ 0.3
- II = Allowable ratio of Moment of Inertia (WR^2) ≤ 3
- III = Allowable ratio of Moment of Inertia (WR^2) ≤ 10

Determine Selection Horsepower (HP)

$$\text{Motor HP} \times \text{Service Factor} = \text{Selection HP}$$

Example: 10 Motor HP X 1.25 Service Factor = 12.5 Selection HP

Select a Frame Size

1 Match your OUTPUT RPM (or RATIO)...

Output RPM Ratio	250	175	146	117	87.5	70.0	58.3	43.8	35.0	29.2	Frame Size
	7	10	12	15	20	25	30	40	50	60	
Input HP	1.07	1.07	1.07								
Output Torque in-lbs	230	328	394								
Overhung Load lbs	353	386	408								
									0.536	0.536	
									617	639	

2 ...to your SELECTION HP... (Example: 12.5 Selection HP)

3 ...to find your FRAME SIZE (Example: S320)

If Overhung Load is present, it must be checked against the capacity of the selection.



For special circumstances affecting Frame Size selection such as:

- Overhung Load
- Shock Loading

Consult page 21.

Configure a Model Number

Nomenclature

Output Shaft Orientation

Type	Prefix
Universal Mounting	N

Mounting Style

Type	Prefix
Hollow Shaft Mount	Y
Solid Shaft without Base	U
Solid Shaft Foot Mount	H

Input Connection

Type	Prefix
NEMA Quill C-Face	X
NEMA Quill C-Face with Motor	XM

Modification

	Prefix
Special	S
Standard	

Required to be added at end of model number when ordering:

- NEMA frame size for C-face or Quill adapter
- Output Bore size (must be specified for units with hollow outputs)

Frame Size

S320
S420

Output Shaft Direction (solid shaft only)

Direction	Suffix
Left Shaft Extension	L
Right Shaft Extension	R

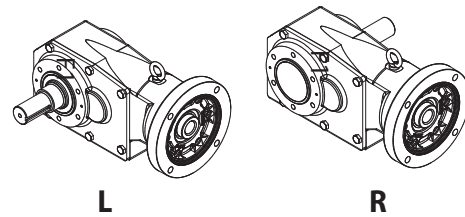

Shaft Specifications (Output)

Hollow	Solid	Suffix
Key (mm)	Key (mm)	
Key (Inch)	Key (Inch)	Y

Optional Specifications

Specification	Suffix
Flange (Left)	F1
Flange (Right)	G1
Solid Plug-in Shaft Only	X1

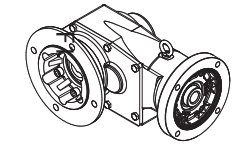

F1

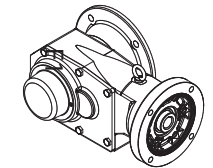

G1

Reduction Ratio

S320	7:1 to 60:1
S420	

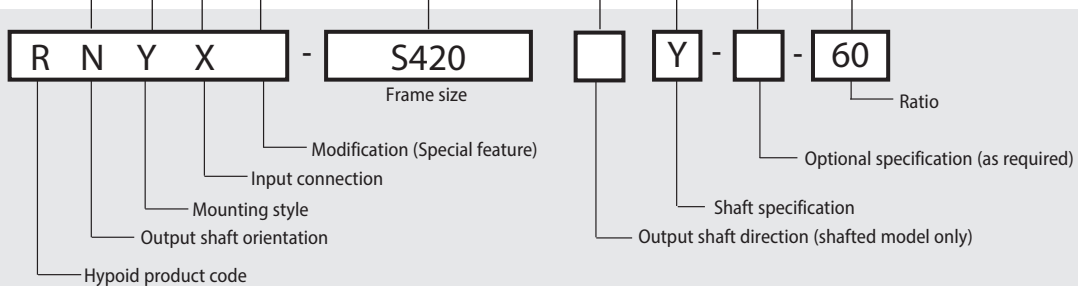

Nomenclature Example:
RNYX – S320 – F1 – 20

R – Hypoid
 N – Universal Mount
 Y – Shaft Mount (Hollow Shaft)
 X – Quill C-Face Input

S320 – Frame Size
Y – Inch Shaft Specification
F1 – Extended flange on Left side (viewed from motor end)
20 – Ratio

AGMA Load Classification

TYPE OF APPLICATION	TYPE OF LOAD
---------------------	--------------

Agitators	
Pure liquids	U
Liquids and solids	M
Variable-density liquids	M
Blowers	
Centrifugal	U
Lobe	M
Vane	U
Brewing and Distilling	
Bottling machinery	U
Brew kettles, cont. duty	U
Cookers, cont. duty	U
Mash tubs, cont. duty	U
Scale hopper, frequent starts	M
Can Filling Machines	U
Cane Knives	M
Car Dumpers	H
Car Pullers	M
Clarifiers	U
Classifiers	M
Clay Working Machinery	
Brick press	H
Briquette machine	H
Clay working machinery	M
Pug mill	M
Compressors	
Centrifugal	U
Lobe	M
Reciprocating, multi-cylinder	M
Reciprocating, single-cylinder	H
Conveyors — Uniformly Loaded or Fed	
Apron	U
Assembly	U
Belt	U
Bucket	U
Chain	U
Flight	U
Oven	U
Screw	U
Conveyors — Heavy Duty, Not Uniformly Fed	
Apron	M
Assembly	M
Belt	M
Bucket	M
Chain	M
Flight	M
Live roll oven	M
Reciprocating	H
Screw	M
Shaker	H
Cranes (Except for Dry Dock Cranes)	
Main hoists	U
Bridge travel	S
Trolley travel	S
Crusher	
Ore H	
Stone	H
Sugar	M
Dredges	
Cable reels	M
Conveyors	M
Cutter head drives	H
Jig drives	H
Maneuvering winches	M
Pumps	M
Screen drive	H
Stackers	M
Utility winches	M
Dry Dock Cranes	S
Elevators	
Bucket, uniform load	U
Bucket, heavy load	M
Bucket, cont.	U
Centrifugal discharge	U
Escalators	U
Freight	M
Gravity discharge	U
Man lifts	S
Passenger	S
Extruders (Plastics)	
Blow molders	M
Coating	U
Film	U
Pipe	U
Pre-plasticizers	M
Rods	U
Sheet	U
Tubing	U
Fans	
Centrifugal	U
Cooling towers	S
Forced draft	S
Induced draft	M
Large (mine, etc.)	M

TYPE OF APPLICATION	TYPE OF LOAD
---------------------	--------------

Large (industrial)	M
Light (small diameter)	U
Feeders	
Apron	M
Belt	M
Disc	U
Reciprocating	H
Screw	M
Food Industry	
Beet slicer	M
Cereal cooker	U
Dough mixer	M
Meat grinders	M
Generators (Not Welding)	U
Hammer Mills	H
Hoists	
Heavy duty	H
Medium duty	M
Skip	M
Laundry Washers — Reversing	M
Laundry Tumblers	M
Line Shaft	
Drive processing equipment	M
Light	U
Other line shafts	U
Lumber Industry	
Barkers — hydraulic and mechanical	S
Burner conveyor	M
Chain Saw and Drag Saw	H
Chain transfer	H
Craneway transfer	H
De-barking drum	S
Edger feed	H
Gang feed	M
Geen chain	M
Live rolls	H
Log haul-lockline	H
Log turning device	H
Main log conveyor	H
Off bearing rolls	M
Planer feed chains	M
Planer floor chains	M
Planer tilting hoist	M
Re-saw merry-go-round conveyor	M
Roll cases	H
Slab conveyor	H
Small waste-conveyor-belt	U
Small waste-conveyor-chain	M
Sorting table	M
Tipple hoist conveyor	M
Tipple hoist drive	M
Transfer conveyors	M
Transfer rolls	M
Tray drive	M
Trimmer feed	M
Waste conveyor	M
Machine Tools	
Bending roll	M
Notching press, belt driven	S
Plate planer	H
Punch press, gear driven	H
Tapping machine	H
Other machine tools	
Main drives	M
Auxiliary drives	U
Metal Mills	
Draw bench carriage and main drive	M
Forming machines	H
Pinch, dryer and scrubber rolls, reversing	S
Slitters	M
Table conveyors, nonreversing	
Group drives	M
Individual drives	H
Table conveyors, reversing	S
Wire drawing and flattening machine	M
Wire winding machine	M
Mills, Rotary Type	
Ball M	
Cement kilns	M
Dryers and coolers	M
Kilns	M
Pebble	M
Rod, plain and wedge bar	M
Tumbling barrels	H
Mixers	
Concrete mixers, cont.	M
Concrete mixers, intermittent	M
Constant density	U
Variable density	M
Oil Industry	
Chillers	M
Oil well pumps	S
Paraffin filter press	M
Rotary kilns	M

TYPE OF APPLICATION	TYPE OF LOAD
---------------------	--------------

Paper Mills	
Agitators (mixers)	M
Barker, hydraulic	S
Barker, mechanical	S
Barking drum	S
Beater and pulper	M
Bleacher	U
Calenders	M
Calenders, super	H
Converting machine (except cutters, platers)	M
Conveyors	U
Couch	M
Cutters, platers	H
Cylinders	M
Dryers	M
Felt stretcher	M
Felt whipper	H
Jordans	H
Log haul	H
Presses	U
Pulp machine reel	M
Stock chest	M
Suction roll	U
Washers and thickeners	M
Winders	U
Printing Presses	S
Pullers, Barge Haul	H
Pumps	
Centrifugal	U
Proportioning	M
Reciprocating	
Single acting, 3 or more cylinders	M
Double acting, 2 or more cylinders	M
Rotary-gear type	U
Rubber and Plastics Industries	
Crackers	H
Laboratory equipment	M
Mixing mills	H
Refiners	M
Rubber calenders	M
Rubber mill (2 on line)	M
Rubber mill (3 on line)	U
Sheeter	M
Tire building machines	S
Tire and tube press openers	S
Tubers and strainers	M
Warming mills	M
Sand Muller	M
Screens	
Air washing	U
Rotary, stone or gravel	M
Traveling water intake	U
Sewage Disposal Equipment	
Bar screens	U
Chemical fenders	U
Collectors, circuline or straightline	U
Dewatering screens	M
Grit collectors	U
Scum breakers	M
Slow or rapid mixers	M
Sludge collectors	U
Thickeners	M
Vacuum filters	M
Slab Pushers	M
Steering Gear	S
Stokers	U
Sugar Industry	
Cane knives	M
Crushers	M
Mills	H
Textile Industry	
Batchers	M
Calenders	M
Cards	M
Dry cans	M
Dryers	M
Dyeing machinery	M
Knitting machines	S
Looms	M
Mangles	M
Nappers	M
Pads	M
Range drives	S
Slashers	M
Soapers	M
Spinners	M
Tenter frames	M
Washers	M
Winders	M
Windlass	S

U = Uniform Load H = Heavy Shock
M = Moderate Shock S = Contact Sumitomo

This page intentionally left blank.

Frame Size Selection Tables

1750 RPM

Output RPM	250	175	146	117	87.5	70.0	58.3	43.8	35.0	29.2	Frame Size
Ratio	7	10	12	15	20	25	30	40	50	60	S320
Input Power HP (kW)	1.29 (0.96)	1.29 (0.96)	1.29 (0.96)	1.29 (0.96)	1.29 (0.96)	1.21 (0.90)	1.21 (0.90)	0.64 (0.48)	0.64 (0.48)	0.62 (0.46)	
Output Torque in-lbs (N-m)	276 (31.2)	394 (44.5)	473 (53.4)	591 (66.8)	788 (89.0)	923 (104)	1110 (125)	788 (89)	984 (111)	1130 (128)	
Solid Shaft OHL lbs (N)	353 (1570)	387 (1720)	407 (1810)	441 (1960)	486 (2160)	508 (2260)	528 (2350)	573 (2550)	618 (2750)	638 (2840)	S420
Input Power HP (kW)	2.30 (1.72)	2.30 (1.72)	2.30 (1.72)	2.30 (1.72)	2.30 (1.72)	2.30 (1.72)	2.30 (1.72)	1.19 (0.89)	1.19 (0.89)	1.19 (0.89)	
Output Torque in-lbs (N-m)	494 (55.9)	706 (79.8)	847 (95.7)	1059 (120)	1410 (159)	1760 (199)	2120 (240)	1460 (165)	1830 (207)	2190 (247)	
Solid Shaft OHL lbs (N)	517 (2300)	585 (2600)	618 (2750)	661 (2940)	717 (3190)	760 (3380)	805 (3580)	859 (3820)	904 (4020)	937 (4170)	

Dimensions

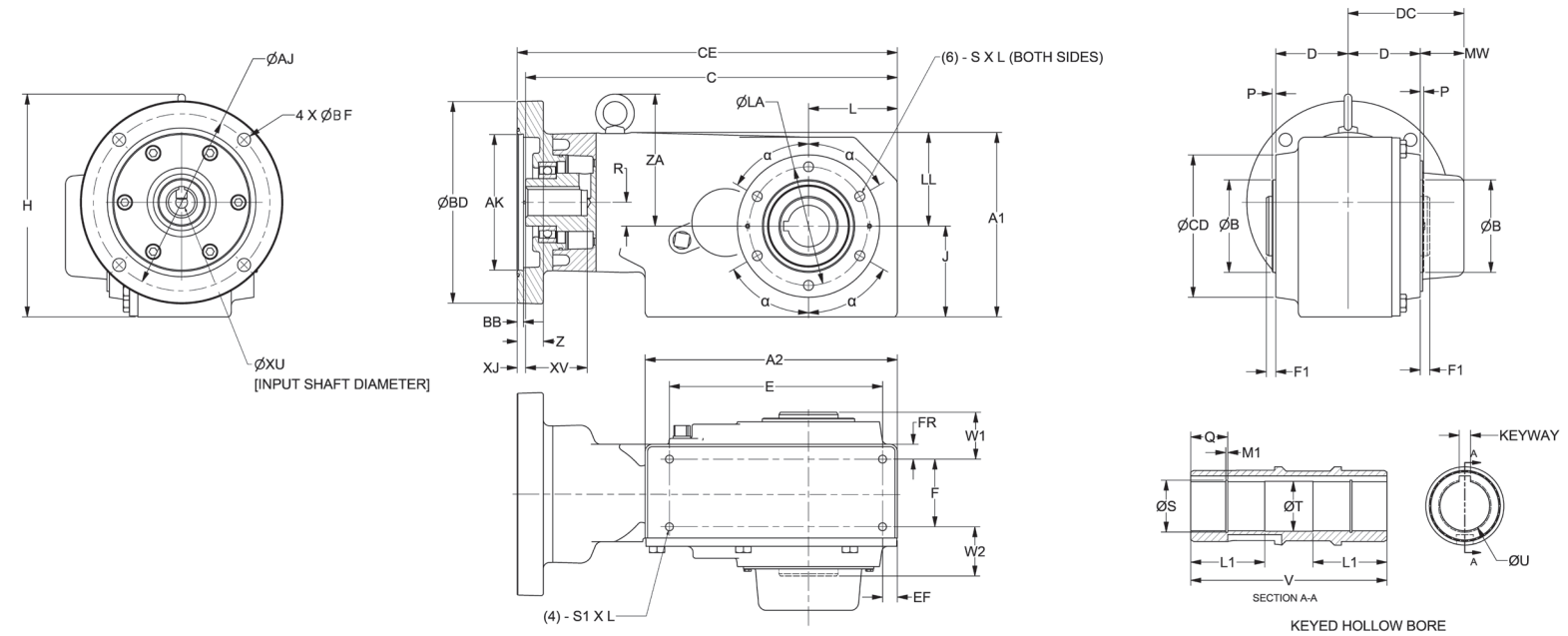

Fortress® Casing

All dimensions are in inches (mm).

Frame Size	S1 x L	A1	A2	ØB	D	E	F	FR	EF	W1	W2	ØLA	S x L	α	LL	L	H	F1	J
S320	M8 x 0.47 (M8 x 12.0)	5.93 (150.5)	6.85 (174)	2.83 (72.0)	1.89 (48.0)	5.91 (150.0)	1.38 (35.0)	0.49 (12.5)	0.49 (12.5)	1.48 (37.5)	1.48 (37.5)	3.39 (86.0)	M8 x 0.47 (M8 x 12.0)	55°	3.40 (86.5)	2.52 (64.0)	7.2 (182.8)	0.28 (7.0)	2.52 (64.0)
S420		6.12 (155.4)	8.39 (213)	3.07 (78.0)	2.40 (61.0)	7.09 (180.0)	2.24 (57.0)		0.45 (11.5)	1.56 (39.5)	1.64 (41.5)	3.94 (100.0)	M10 x 0.67 (M10 x 17.0)		60°	3.11 (78.9)	2.95 (75.0)	7.4 (187.8)	0.31 (8.0)

Frame Size	P	D2	ZA	MW	DC
S320	0.12 (3.0)	3.94 (100.0)	4.68 (118.8)	1.18 (30)	3.35 (85.0)
S420		4.72 (120.0)	4.38 (111.3)	1.46 (37.0)	3.86 (98.0)

Frame Size	Weight lbs (Kg)
S320	30.7 (14)
S420	43 (19.5)

Quill Adapter

Frame Size	NEMA Frame	Ratio	ØXU	XV	XJ	KEYWAY	CE	C	AK	ØBD	ØAJ	ØBF	R	Z	BB
S320	56C	7 ~ 30	0.625 (15.875)	1.92 (49)	0.28 (7.0)	3/16 x 3/16 x 1.92	10.90 (276.7)	10.62 (269.7)	4.50 (114.3)	6.69 (170)	5.88 (149.2)	0.43 (11.0)	1.08 (27.5)	0.87 (22.0)	0.20 (5.1)
		40 ~ 60													
S420	143TC	7 ~ 30	0.875 (22.225)	2.0 (51)	0.28 (7.0)	3/16 x 3/16 x 1.82	12.64 (320.9)	12.36 (313.9)	4.50 (114.3)	6.69 (170)	5.88 (149.2)	0.43 (11.0)	0.79 (20.0)	0.87 (22.0)	0.20 (5.1)
		7 ~ 60	0.875 (22.225)												

Keyed Hollow Bore

Frame Size	ØU	U Tolerance	V	ØS	L1	Q	M1	ØT	KEYWAY
S320	1.25 (31.75)	0.0013/ 0.0005 (+0.033/ +0.013)	4.33 (110)	1.33 (33.78)	1.81 (46)	0.827 (22)	0.056 (1.42)	1.28 (32.4)	0.25 x 4.33
S420	1.375 (34.93)	0.0015/ 0.0006 (+0.039/ +0.014)	5.43 (137.93)	1.46 (37.1)	2.05 (52.07)	1.02 (25.9)		1.4 (35.56)	

Flange

Frame Size S320 ~ S420

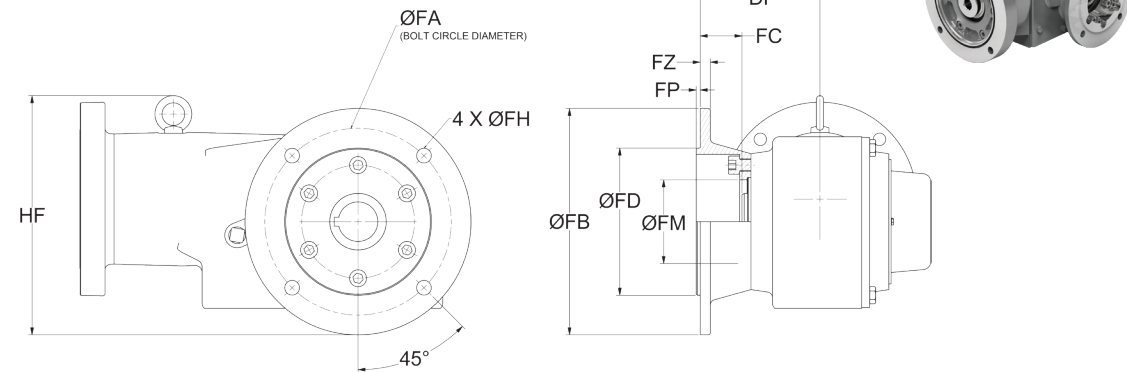

All dimensions are in inches (mm).

Frame Size	B5 Flange Size	ØFB	ØFD	ØFA	FZ	FP	ØFH	ØFM	FC	HF	DF
S320	IEC 71	6.30 (160)	4.33 (110)	5.12 (130)	0.35 (9)	0.14 (3.5)	0.43 (11)	2.56 (65)	1.08 (28)	7.83 (199)	3.25 (83)
S420	IEC 80	7.87 (200)	5.12 (130)	6.50 (165)			0.51 (13)	2.91 (74)	1.46 (37)	8.32 (211)	4.17 (106)

Foot

Frame Size S320 ~ S420

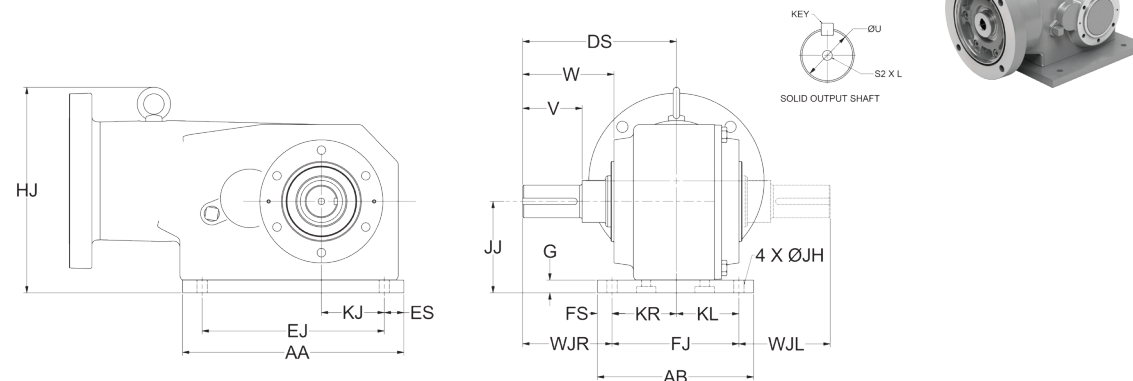

All dimensions are in inches (mm).

Frame Size	EJ	FJ	ØJH	AA	AB	KJ	KR	KL	ES	FS	G	JJ	W	DS	HJ	WJR	WJL
S320	5.88 (149.4)	4.55 (115.6)	0.39 (10.0)	8.50 (215.9)	6.00 (152.4)	2.06 (52.2)	2.25 (57.2)	2.25 (57.2)	1.31 (33.2)	0.72 (18.4)	0.50 (12.7)	3.02 (76.7)	2.60 (66.0)	4.61 (117.0)	7.68 (195.0)	2.36 (59.9)	2.36 (59.9)
S420	7.06 (179.3)	4.88 (124.0)				2.45 (62.2)	2.48 (62.9)	2.48 (62.9)	0.72 (18.3)	0.56 (14.2)		3.51 (89.2)	3.39 (86.0)	5.91 (150.0)	7.89 (200.5)	3.43 (87.1)	3.51 (89.2)

Frame Size	U	W	V	S2 X L	Key
S320	1.25 (28)	2.72 (69.0)	1.65 (42.0)	5/16-18 UNC X 0.63 (M8X1.25 X 16)	1.25 x 1.25 (8 x 8)
S420	1.375 (32)	3.50 (89.0)	2.28 (58.0)		.3125 x .3125 (11 x 11)

Torque Arm

Frame Size S320 ~ S420

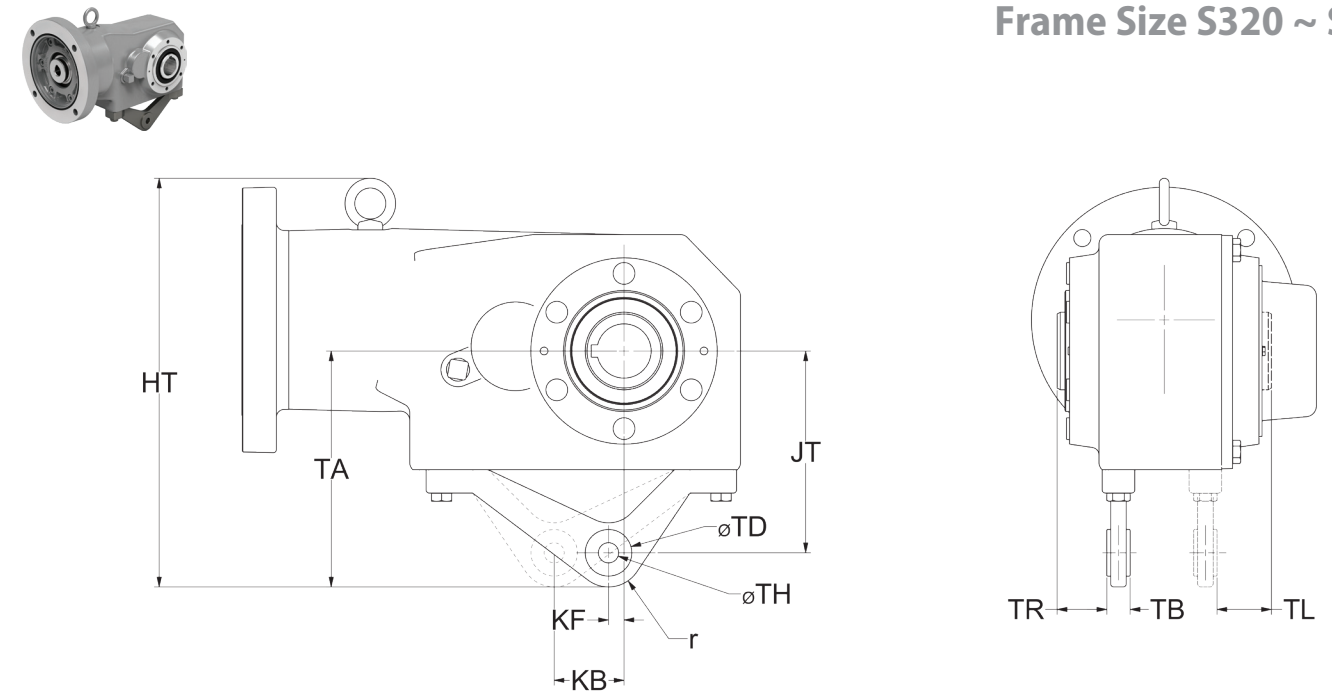

Note: Torque arm can be mounted at KF/TR or KB/TL locations

All dimensions are in inches (mm).

Frame Size	JT	KF	KB	TB	ØTH	ØTD	HT	TA	TL	TR
S320	4.13 (105)	0.89 (23)	0.89 (23)	0.59 (15)	0.43 (11)	1.18 (30)	9.62 (244)	4.94 (126)	1.18 (30)	1.18 (30)
S420	5.12 (130)	0.39 (10)	1.77 (45)		0.51 (13)		10.37 (263)	5.98 (152)	1.38 (35)	1.26 (32)

Shrink Disc

A shrink disc provides a reliable, keyless, high-strength connection to the driven shaft with zero backlash. It is ideal for applications that typically require an interference between the shaft and hollow bore. Sumitomo strongly recommends a shrink disc for applications involving frequent starts.

When ordering, use the Special Specification Code R61 for right side (when viewed from the motor end), or R62 for left side (when viewed from the motor end).

The user shaft should conform to JIS h6 tolerances. Shafts outside that range may not develop sufficient clamping force. The shaft surface finish should be between 63 to 125 micro-inches RMS.

Table 1: Shrink Disc Availability

Bore Size (in.)	Driven Shaft Tolerance (JIS h6)	Frame Size	
		S320	S420
7/8	+0.0000 -0.0051	◆	
15/16	+0.0000 -0.0051	◆	
1	+0.0000 -0.0051	◆	
1-1/8	+0.0000 -0.0051	◆	
1-3/16	+0.0000 -0.0063	◆	
1-1/4	+0.0000 -0.0063	◆	◆
1-3/8	+0.0000 -0.0063		◆
1-7/16	+0.0000 -0.0063		◆

Symbols:

◆ Standard Stainless Steel (AISI 304)

Shaft Availability

Table 2: Hollow Shaft Availability

Bore Size (in.)	Frame Size	
	S320	S420
3/4	◆	
13/16	◆	
7/8	◆	
15/16	◆	
1	◆	◆
1-1/8	◆	◆
1-3/16	◆	◆
1-1/4	◆	◆
1-5/16		◆
1-3/8		◆
1-7/16		◆

Table 3: Solid Shaft Availability

Bore Size (in.)	Frame Size	
	S320	S420
1-1/4	◆	
1-3/8		◆

Bore Size (mm)	Frame Size	
	S320	S420
28	◆	
32		◆

Symbols:

◆ Standard Stainless Steel (AISI 304)

Bore Size (mm)	Frame Size	
	S320	S420
20	◆	
25	◆	◆
30	◆	◆
35		◆

Shaft Rotation

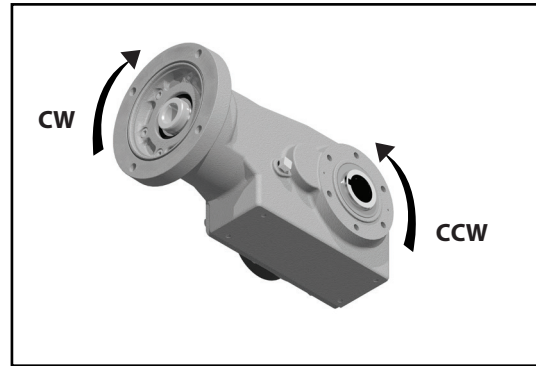

Actual Reduction Ratio

Table 4: Actual Reduction Ratios for Nominal Ratios 7 ~ 60

Frame Size	Nominal Ratio (:1)									
	7	10	12	15	20	25	30	40	50	60
S320	7.03	9.81	11.74	15.26	20.67	24.62	30.00	41.33	49.23	60.00
S420	6.97	10.00	11.96	14.75	19.69	25.00	30.45	39.38	50.00	60.91

Special Load Guidelines Overhung Load

Reducer/Gearmotor Allowable Overhung Load

When a sprocket, sheave, or gear is mounted on the shaft of a reducer, an overhung load is applied on that shaft. It is necessary to check if the shaft of the Fortress® Speed Reducer will allow the overhung load. Calculate the overhung load using this formula:

$$Pr = \frac{TI}{R} \leq \frac{Pro}{Lf \cdot Cf \cdot Fs} \quad (\text{lbs, N})$$

LEGEND

- Pr: Actual radial load (lbs, N)
- TI: Actual transmitted torque on slow speed shaft of reducer (lb·in, N·m)
- R: Pitch circle radius of sprocket, gear, pulley, ect. (inch, meter)
- Pro: Allowable radial load (lbs, N)
- Cf: Coupling factor
- Fs: Shock factor
- Lf: Load Location factor = 1.0

Table 5: Load Connection Factor

Type of Connection	Cf	
General Purpose Chain	Single Row	1.00
	Double Row	1.25
Machined Gear or Pinion	1.25	
Synchronous Belt	1.50	
V-Belt	1.50	
Flat Belt	2.50	

Table 6: Shock Factor

Shock Factor	Fs
No Shock	1.0
Moderate Shock	1.3
Heavy Shock	1.6

Table 7: RNFM-X1, RNHM-J1 Slow Speed Shaft Load Location Factor (Lf)

Frame Size	L (in.)									
	1/2	3/4	1	1-1/4	1-1/2	1-3/4	2	2-1/4	2-1/2	2-3/4
S320	1.13	1.19	1.25	1.32	1.38	1.44	1.51	1.57	1.64	1.70
S420	1.13	1.19	1.25	1.30	1.30	1.34	1.41	1.47	1.54	1.60

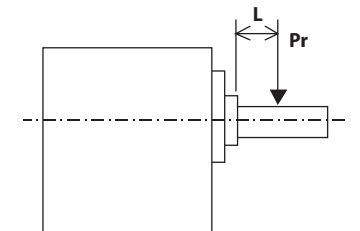

Figure: 2

Special Load Guidelines Inertia

Table 8: Reducer Moment of Inertia, Ratios 7 ~ 60 Units: lb-inch² (x 10⁻⁴ kg-m²)

Frame Size	Reduction Ratio									
	7	10	12	15	20	25	30	40	50	60
S320	0.336	0.323	0.317	0.310	0.304	0.302	0.300	0.238	0.238	0.237
S420	0.607	0.566	0.553	0.540	0.525	0.515	0.510	0.367	0.364	0.363

Mounting

Recommended Shaft Tolerances for Hollow Bore Fortress®

According to JIS standard and based on loading conditions, recommended shaft tolerances for hollow bore Fortress® are:

- Steady, uniform loads: **JIS h6/js6 (low shock load)**
- Shock load or large overhung load: **JIS js6/k6 (high shock load)**
- Snap ring size is in accordance with: **JIS B2804C**

Refer to tables 9 and 10 for corresponding shaft diameters.

Table 9: Metric Bore Shaft Diameters (mm)

Bore Size	Low Shock Load JIS h6/js6		High Shock Load JIS js6/k6	
	Min	Max	Min	Max
20	19.9870	20.0065	19.9935	20.0150
25	24.9870	25.0065	24.9935	25.0150
30	29.9870	30.0065	29.9935	30.0150
35	34.9840	35.0080	34.9920	35.0180

Table 10: Inch Bore Shaft Diameters (in.)

Bore Size	Low Shock Load JIS h6/js6		High Shock Load JIS js6/k6	
	Min	Max	Min	Max
3/4	0.74950	0.75025	0.74975	0.75060
13/16	0.81200	0.81275	0.81225	0.81310
7/8	0.87450	0.87525	0.87475	0.87560
15/16	0.93700	0.93775	0.93725	0.93810
1	0.99950	1.00025	0.99975	1.00060
1-1/8	1.12450	1.12525	1.12475	1.12560
1-3/16	1.18700	1.18775	1.18725	1.18810
1-1/4	1.24940	1.25030	1.24970	1.25070
1-5/16	1.31190	1.31280	1.31220	1.31320
1-3/8	1.37440	1.37530	1.37470	1.37570
1-7/16	1.43690	1.43780	1.43720	1.43820

Accessories Output Shaft Safety Cover, Torque Arm

Output Shaft Safety Cover

Included with all hollow bore models.

Table 11: Output Shaft Safety Cover Dimensions for keyed hollow bore.

Symbols: M: Screw size P: Thread pitch L: Thread length P.C.D: Mounting pitch N: Quantity

Frame Size	Safety Cover							Output Shaft End		Fig. #
	A	øB	C°	D	t	øP.C.D	N	MxPxL (mm)	øE	
S320	1.18	3.03	5	R0.20	0.08	3.46	2	M3x0.5x6	2.17	3
S420	1.18	3.54	5	R0.20	0.08	4.06	2	M3x0.5x6	2.56	3

Note: Safety cover dimensions may differ for shrink disc hollow shafts.

Figure 3: Frame Sizes S320~S420

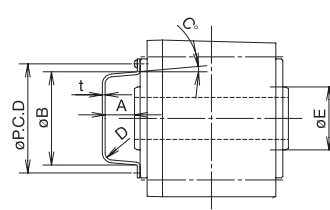

Accessories Torque Arm

Use the formulas below to calculate **torque arm strength, drive shaft strength and bearing life.**

Torque arm load: $R = \frac{T + AG \cdot G}{AR}$

Brg. 1 load: $B = \frac{m(R-G) - YR \cdot R}{l}$

Brg. 2 load: $BW = \frac{(l + M)(R-G) - YR \cdot R}{l}$

Bending Moment at Critical Point B: $M = YR \cdot R - Y(R-G)$ for $0 < Y \leq m$

Symbols:

- T:** Output torque (in-lb) [positive on the shown rotation; negative on the opposite rotation.]
- G:** Fortress® drive gravity (lb)
- R:** Torque arm load (lb)
- AG:** Distance between the center of driven shaft and center of gravity
- AR:** Distance from driven shaft center to torque arm (in.)
- YR:** Distance from the center of Fortress® drive to torque arm whirl stop (in.)
- m:** Distance from the center of Fortress® drive to Brg. 2 (in.)
- l:** Distance between Brg. 1 and Brg. 2 (in.)
- Y:** Distance between the center of Fortress® drive and Critical Point B

Figure 4: Fortress® Torque Arm

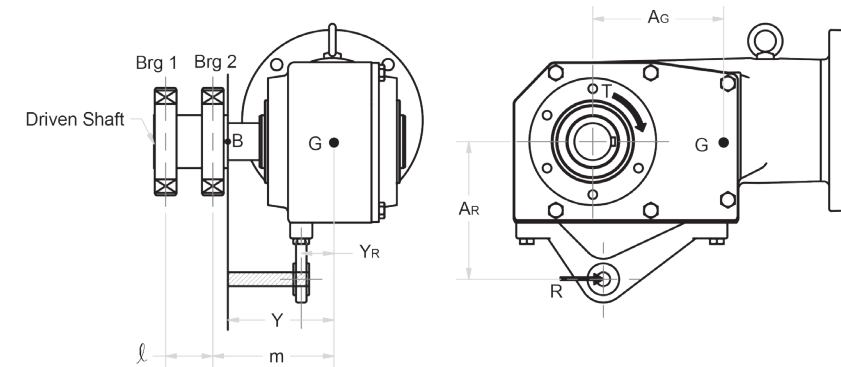

Frame Size	AG (in.)
S320	3.48
S420	3.25

Lubrication

Fortress® drives are filled with long-life grease, **Cassida Grease SGG 000**, and sealed, so replenishment is unnecessary, but overhaul in approximately 20,000 hours or three to five years of operation will provide longer service life. Operating conditions affect oil seal durability. Under severe conditions, they may require changing in less than 20,000 hours or three years of operation. Gearmotors must be overhauled at factory-authorized locations.

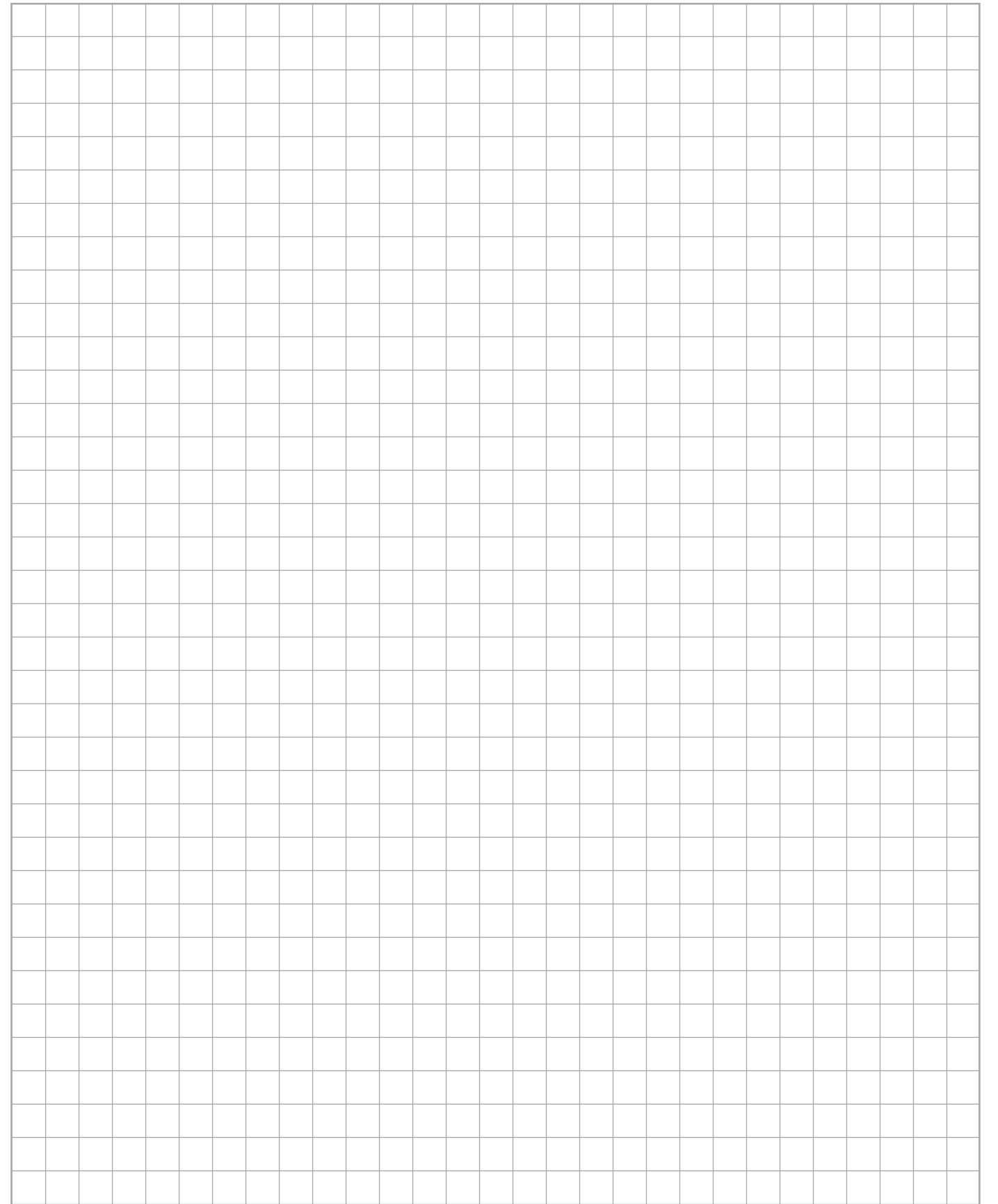
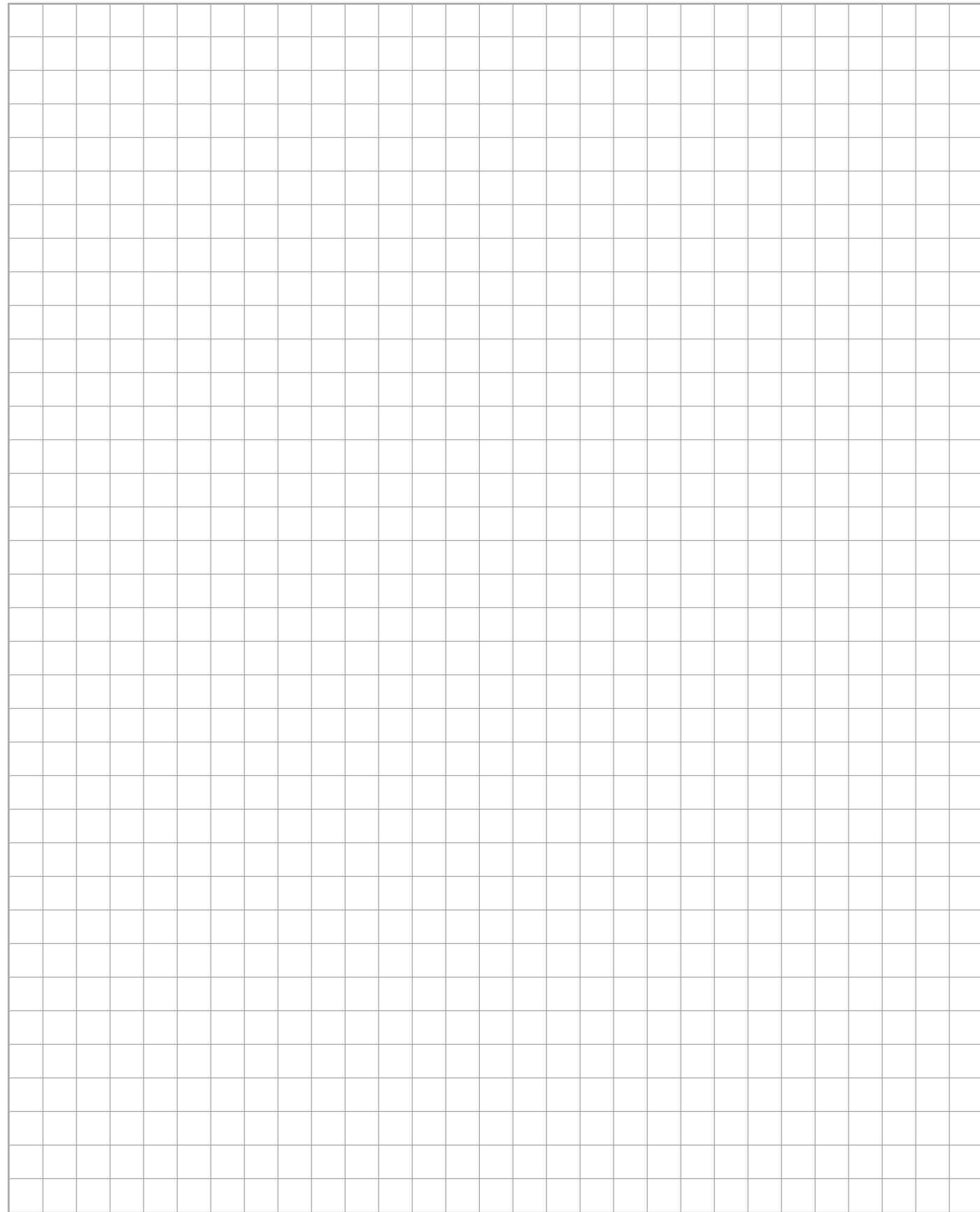

Sumitomo Drive Technologies

 Sumitomo Machinery Corporation of America
Headquarters & Manufacturing
4200 Holland Boulevard, Chesapeake, VA 23323

Sumitomo Machinery Corp. of America
Chesapeake, VA
Glendale Heights, IL
Verona, VA

Phone:
+1.757.485.3355
+1.630.752.0200
+1.540.213.2442

Fax:
+1.757.485.7490
+1.630.752.0208
+1.540.213.2222

SM Cyclo de Mexico, S.A. de C.V.
Monterrey
Guadalajara
Ciudad de México

+52.81.8144.5130
+52.33.3675.4323
+52.55.2282.8700

+52.81.8144.5130 ext. 3109
+52.33.3675.4418
+52.55.2282.8700

SM Cyclo of Canada, Ltd.
Toronto, ON
Vancouver, BC

+1.905.469.1050
+1.604.525.5403

+1.905.469.1055
+1.604.525.0879

SM Cyclo Colombia, S.A.S.
Bogotá

+57.1.300.0673

+57.1.300.0673 ext. 105

Sumitomo Indústrias Pesadas do Brasil Ltda.
São Paulo

+55.11.4403.9292

+55.11.4403.9292

SM Cyclo de Chile Ltda.
Santiago
Antofagasta
Concepción

+56.2.2892.7000
+56.5.5256.1611
+56.41.246.9806

+56.2.2892.7001
+56.5.5256.1616
+56.41.246.9171

SM Cyclo de Guatemala Ensambladora, Ltda.
Guatemala

+502.6648.0500

+502.6648.9171

SM Cyclo de Argentina, SA
Buenos Aires

+54.3327.45.4095

+54.3327.45.4099

World Headquarters

Japan
Sumitomo Heavy Industries, Ltd.
Power Transmission & Controls Group
ThinkPark Tower, 1-1, Osaki 2-chome,
Shinagawa-ku, Tokyo 141-6025 Japan
Tel: +81-367-37-2511 • Fax: +81-368-66-5160

www.sumitomodrive.com

E-mail: Customer_Service@suminet.com

Catalog 12.001.50.016.SS

©2025 Sumitomo Machinery Corporation of America Printed in USA