

Sumitomo Drive Technologies

Sumitomo Machinery Corporation of America
Headquarters & Manufacturing
 4200 Holland Boulevard, Chesapeake, VA 23323



Sumitomo Machinery Corp. of America
 Chesapeake, VA
 Glendale Heights, IL
 Verona, VA

Phone: +1.757.485.3355
 +1.630.752.0200
 +1.540.213.2442
 Fax: +1.757.485.7490
 +1.630.752.0208
 +1.540.213.2222

SM Cyclo de Mexico, S.A. de C.V.
 Monterrey
 Guadalajara
 Ciudad de México

+52.81.8144.5130
 +52.33.3675.4323
 +52.55.2282.8700
 +52.81.8144.5130 ext. 3109
 +52.33.3675.4418
 +52.55.2282.8700

SM Cyclo of Canada, Ltd.
 Toronto, ON
 Vancouver, BC

+1.905.469.1050
 +1.604.525.5403
 +1.905.469.1055
 +1.604.525.0879

SM Cyclo Colombia, S.A.S.
 Bogotá

+57.1.300.0673
 +57.1.300.0673 ext. 105

Sumitomo Indústrias Pesadas do Brasil Ltda.
 São Paulo

+55.11.4403.9292
 +55.11.4403.9292

SM Cyclo de Chile Ltda.
 Santiago
 Antofagasta
 Concepción

+56.2.2892.7000
 +56.5.5256.1611
 +56.41.246.9806
 +56.2.2892.7001
 +56.5.5256.1616
 +56.41.246.9171

SM Cyclo de Guatemala Ensambladora, Ltda.
 Guatemala

+502.6648.0500
 +502.6648.9171

SM Cyclo de Argentina, SA
 Buenos Aires

+54.3327.45.4095
 +54.3327.45.4099

World Headquarters

Japan
 Sumitomo Heavy Industries, Ltd.
 Power Transmission & Controls Group
 ThinkPark Tower, 1-1, Osaki 2-chome,
 Shinagawa-ku, Tokyo 141-6025 Japan
 Tel: +81-367-37-2511 • Fax: +81-368-66-5160

www.sumitomodrive.com
E-mail: Customer_Service@suminet.com

Catalog 04.601.50.012
 ©2025 Sumitomo Machinery Corporation of America Printed in USA

Sumitomo Drive Technologies

HSM

Shaft Mounted Speed Reducer and CEMA Screw Conveyor Drive

Sumitomo Drive Technologies



HSM
Shaft Mounted Speed Reducer
and CEMA Screw Conveyor Drive
 featuring Keyless Taper-Grip® Bushing

Keyless Taper-Grip® Bushing
Supplied as standard in popular AGMA bore sizes and in metric. Optional keyed hollow bore is also available.

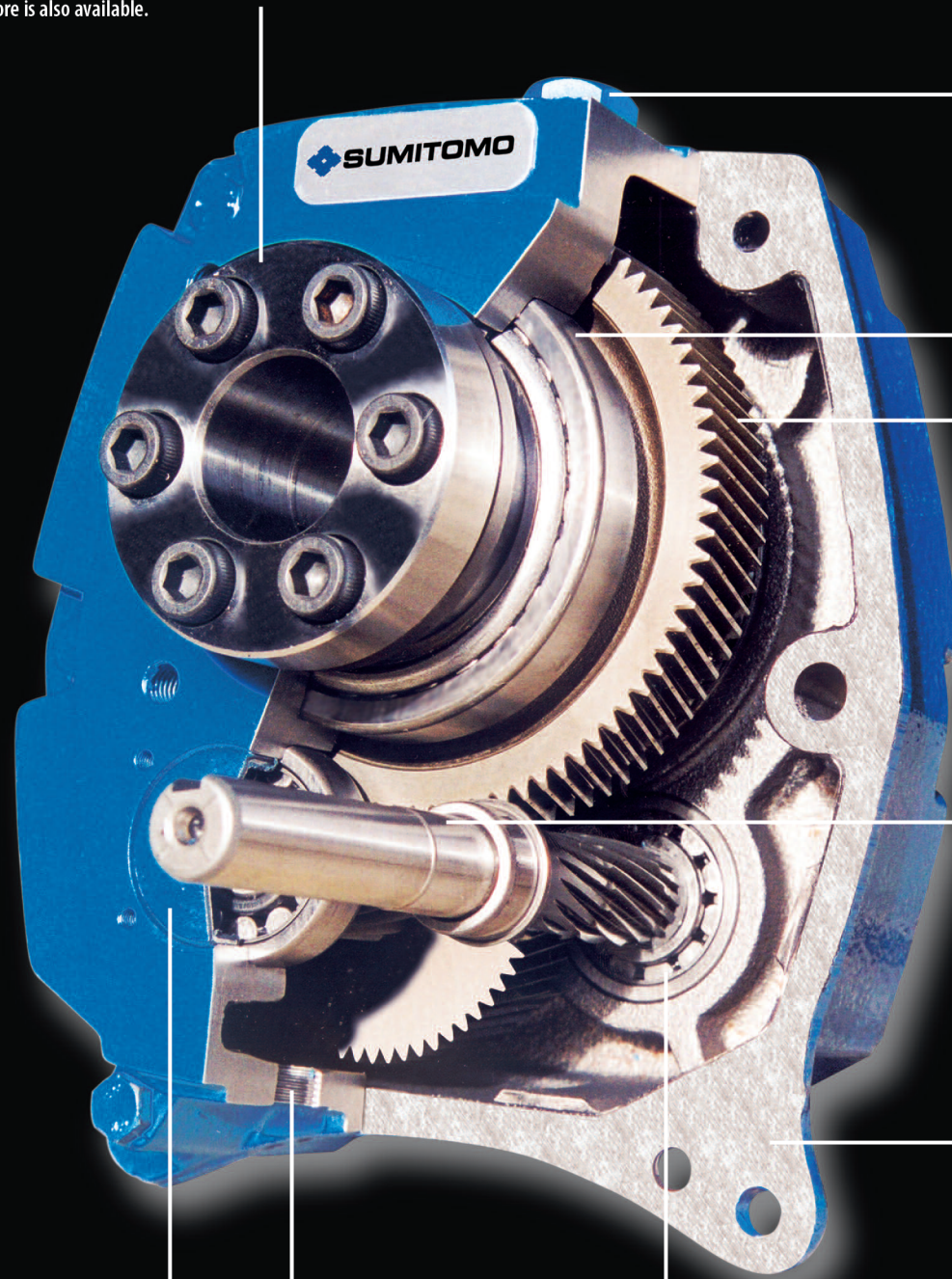

Breather Plug
With integral sealing washer and built-in non-return valve.

Tapered Roller Bearings
Supplied as standard.

Gears
Helical, involute form, alloy steels, gas carburized and hardened, shaved and honed (profile ground on selected sizes) insuring low noise emission. The hunting tooth principle adopted to insure maximum working life.

Shafts
Machined from alloy steels and precision ground on journals, gear seatings and extensions. Tolerances and keyways conform to international standards.

Additional Case Lugs
Eliminate the need for critical tightening of torque arm bolts. Control position of standard torque arm mounting to within recommended limits.

Rubberized End Caps
Self-sealing intermediate cover plates, to standard ISO housing dimensions.

Drain Plugs
With integral sealing washer.

Backstops (anti-run back device)
Available on all units as an add-on option.



Cyclo® BBB4
Right Angle, Spiral Bevel Gearbox with Cyclo® Reducer Input.



Cyclo® BBB5
Right Angle, Spiral Bevel Gearbox with Cyclo® Reducer Input.



Hyponic®
Features all-steel hypoid gear design, maintenance-free grease lubrication and high efficiency operation.



Cyclo® HBB
Parallel Shaft, Helical Gearbox with Cyclo® Reducer Input; features keyless, steel Taper-Grip® Bushing for easy mounting.



HSM
Helical Shaft Mounted Speed Reducer available with CEMA Screw Conveyor Drive Option.



Paramax® 9000
Right Angle and Offset Parallel Industrial Gearboxes in Universal Housing.

**Trying to select a drive?
Need more technical specifications?
Need pricing?**



Sumitomo Drive Technologies' online product Configurator streamlines the selection process, enabling you to build our power transmission products for your specific application*.

Available 24 hours a day, 7 days a week, registered users quickly receive results that include:

- ▶ Download 2D and 3D CAD files
- ▶ Product literature
- ▶ Technical specification sheet
- ▶ Product ratings
- ▶ Request for quote**
- ▶ Quotations**

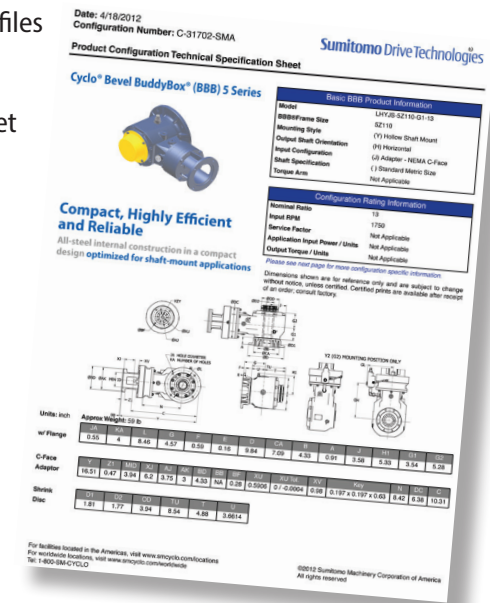

This unique interactive tool is one more reason Sumitomo Drive Technologies is the world's premier power transmission and control solutions provider.

* Not all products are available for configuration
** Not available for all markets.

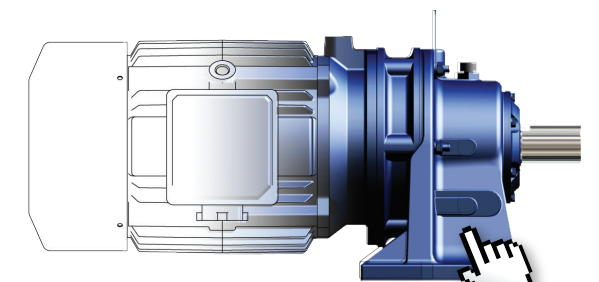

Configure your Cyclo® today at
www.sumitomodrive.com/Configurator

HSM

Shaft Mounted Speed Reducer and CEMA Screw Conveyor Drive

Featuring Keyless Taper-Grip® Bushing

Table of Contents

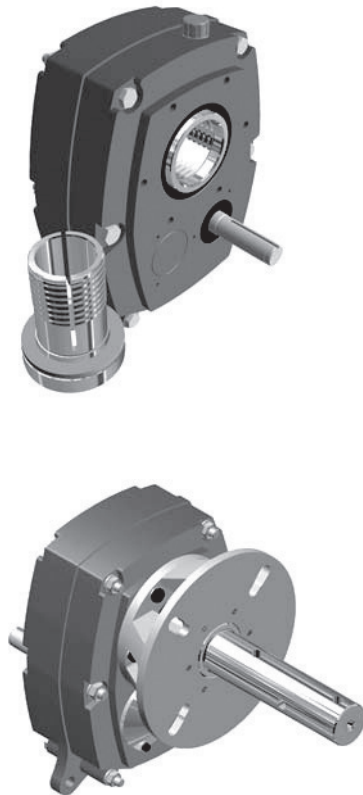

General Information	2
Accessories	4
Selection and Specifications	
How to Select	6
AGMA Classification Tables	8
Gear Box Selection Tables.....	11
Class I.....	11
Class II.....	23
Class III	35
Power Ratings	46
CEMA Screw Conveyor Drives	48
Sheave Diameters.....	50
Dimensions	
Sizes 107-307.....	52
Sizes 315-608.....	54
Motor Mounts.....	56
Extended Motor Mounts.....	57
Belt Guards	58
Extended Belt Guards	59
Installation	60
Lubrication.....	61
Warranty	62

HSM Shaft Mounted Speed Reducer and CEMA Screw Conveyor Drive

Featuring Keyless Taper-Grip® Bushing

The Sumitomo **Helical Shaft Mount (HSM)** Speed Reducer provides a convenient installation and removal method for speed reduction by mounting directly on the drive shaft. Sumitomo's Taper-Grip® bushing provides simple keyless mounting and easy removal. HSM is readily adaptable for CEMA screw conveyor and shaft mount options. The HSM features carburized gear teeth with optimal gear geometry and wide gear faces, allowing maximum loading and highest efficiency torque output, for higher rating capacity in the most compact design.

Features & Benefits

- Higher ratings with a 25° pressure angle and wider gear tooth face for maximum torque
- Keyless shaft connection with Taper-Grip® bushing for easy installation and removal, simple replacement
- Heavy duty roller bearings for maximum strength and extended life
- AGMA standard bore sizes in both bushed and through-bore simplify specification and retrofit
- CEMA standard screw conveyor options
- Optional Taconite sealing systems for effective protection in severe applications and extended operation
- Drop in replacement for all AGMA-style units
- Flexible motor mounting capabilities
- Backstops with centrifugal lift-off sprags to maximize reliability

Specifications

- Ratios:** 5:1, 14:1, 20:1, 25:1
HP: 1/4 to 300
Sizes: AGMA 107 to 608
Bore Sizes: 1 3/16" to 6 1/2", metric optional
Mounts: Vertical, Horizontal, and Direct drive mounting configurations
Lubrication: Oil lubrication, synthetic lubricant optional
Housing: Cast iron case construction
Screw Conveyor: CEMA Standards

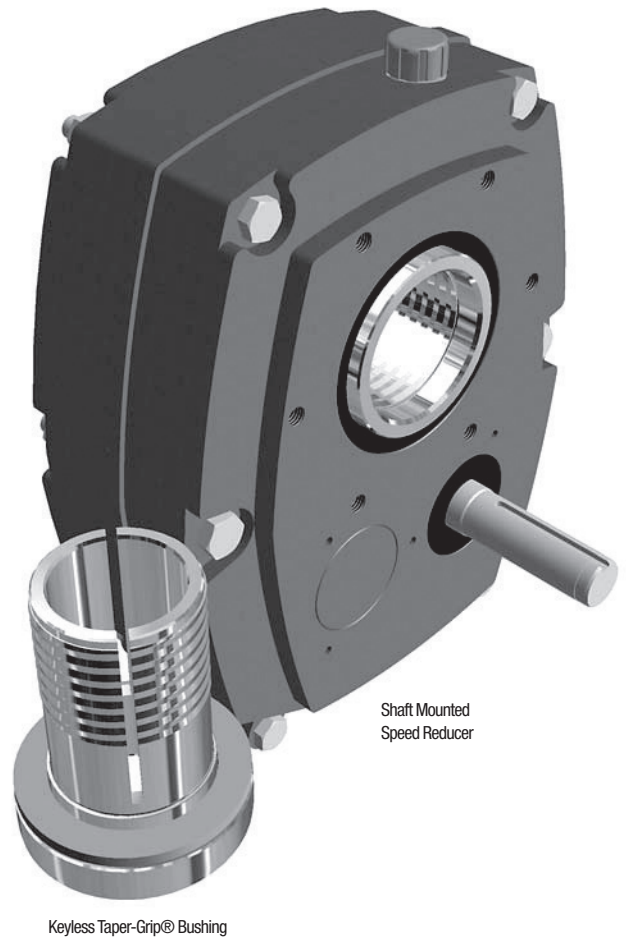

Applications

Perfect for screw conveyors, belt conveyor bulk handling machinery and process equipment for:

- Baggage Handling
- Pulp, Paper, & Forestry
- Aggregate & Mining
- Mixers & Process Equipment
- Grain & Agriculture



DESIGNED TO
CEMA
Specifications

HSM CEMA SCREW CONVEYOR DRIVE

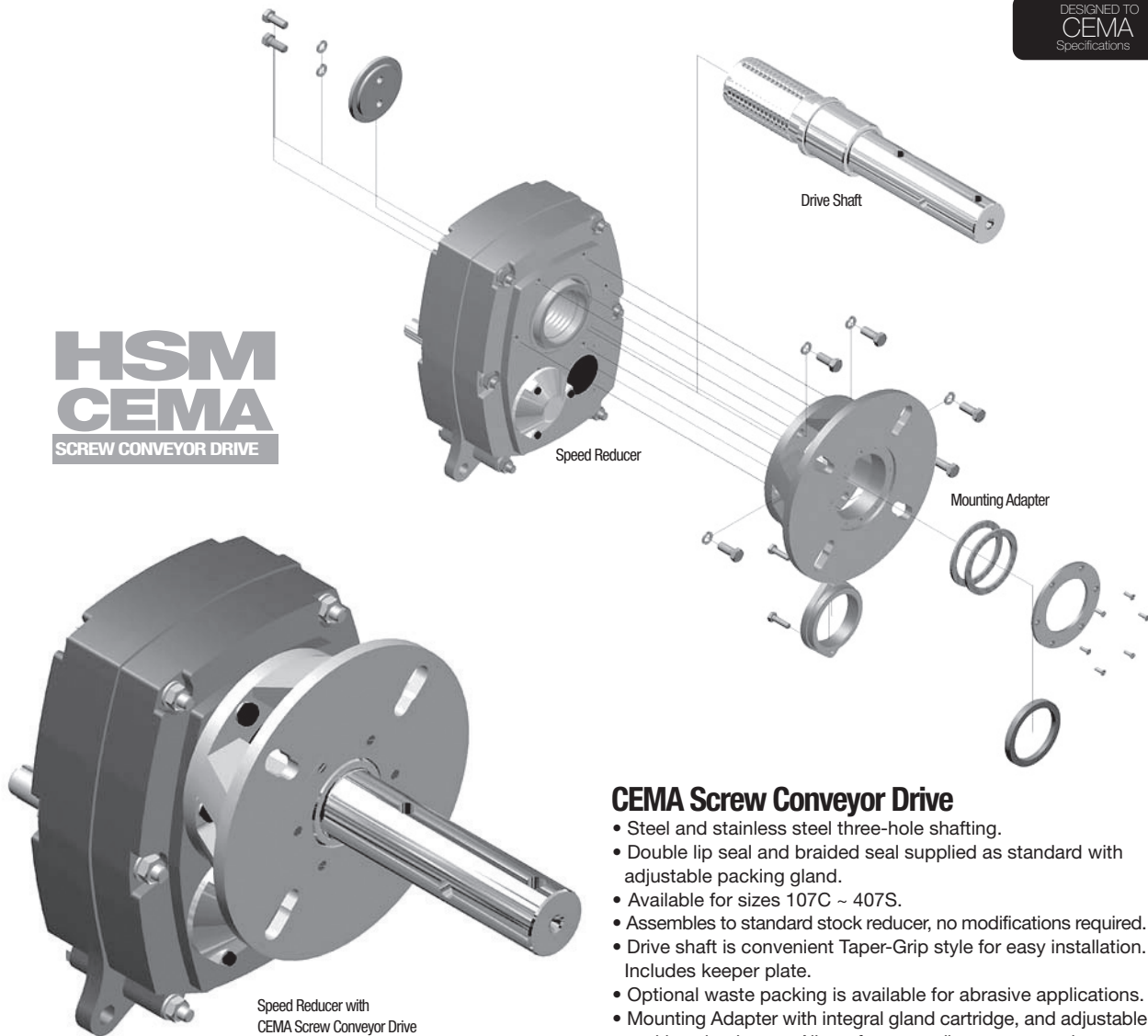

CEMA Screw Conveyor Drive

- Steel and stainless steel three-hole shafting.
- Double lip seal and braided seal supplied as standard with adjustable packing gland.
- Available for sizes 107C ~ 407S.
- Assembles to standard stock reducer, no modifications required.
- Drive shaft is convenient Taper-Grip style for easy installation. Includes keeper plate.
- Optional waste packing is available for abrasive applications.
- Mounting Adapter with integral gland cartridge, and adjustable packing gland cover. Allows for easy adjustment or replacement without removing trough end or gearbox.

See page 48 to specify CEMA Screw Conveyor Drives

Taper-Grip® Bushing

The HSM Shaft Mounted Speed Reducer is secured to the driven shaft by means of a Taper-Grip® bushing that transmits the torque and shock overload capacity of the selected reducer.

Features

- Requires no key or keyway.
- Resistant to fretting.
- Easy to assemble and position the HSM on the driven shaft.
- Usable from either side of the gearbox as standard.
- Allows the driven shaft diameter tolerances to be a clearance fit.
- Easy to remove the HSM from the driven shaft.
- Both inch and metric shaft bores available.
- Fits a wide selection of shaft diameters.
- May be used with existing keyed shafts.
- Superior shaft gripping capability provided by a series of short tapers in the form of a continuous helix.

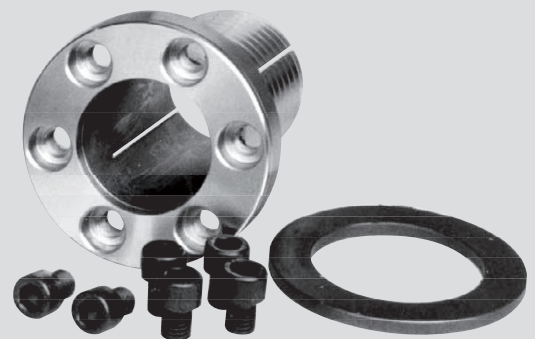

Accessories

Simple, Reliable, Modular Accessory Kits Provide Maximum Inventory Flexibility

Backstops

- New centrifugal design maximizes reliability, minimizes wear and extends life.
- Simple field installation insures correct direction of operation.
- Internal mounting minimizes maintenance, insures continual flow of fresh lubrication.
- Easily reversed for operation in either direction.

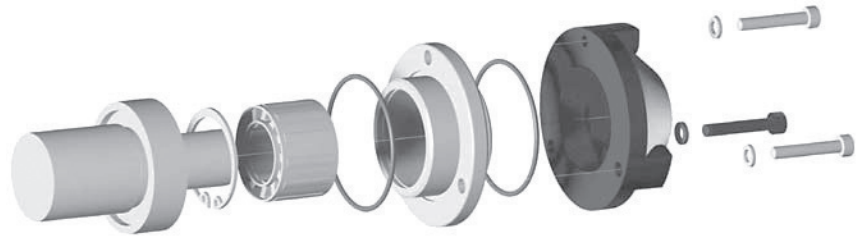

Belt Guards

- Minimum number of parts allow for quick installation.
- Constructed with expanded metal grill.
- Painted safety yellow.
- Assembles using existing reducer and top mount holes.
- Sized to fit a wide range of sheave diameters.
- Includes mounting hardware.

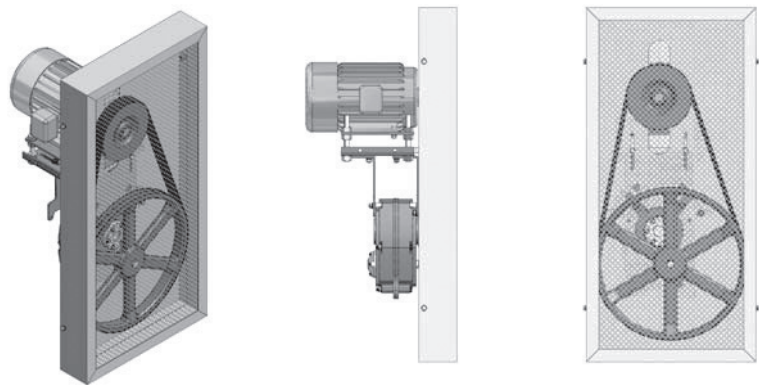

Motor Mounts

- Wrap-around, wide base design provides added stability.
- Rugged all steel construction and four bolt mounting provide maximum rigidity.
- Accommodates both shaft mounted and screw conveyor drive requirements.
- Pre-drilled top plates facilitate using a wide variety of NEMA motors.
- Faster, more economical and more reliable than remote motor mounting.

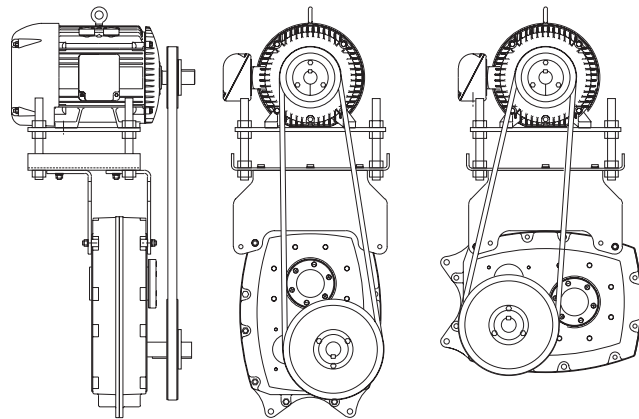

Direct Drive

- Direct mount NEMA or IEC C-face motors.
- Allows for compact geared motor design.
- Eliminates need for belts, pulleys and guards.

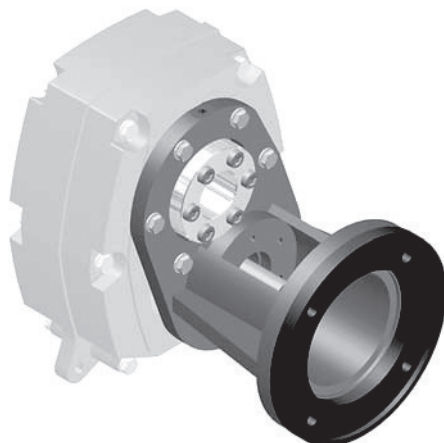

Severe Duty Sealing System

- Outdoor service, washdown duty and taconite type systems available.
- Extends reducer life by providing additional barriers to contaminants.
- Targeted to specific application requirements.
- Includes both seals and breather elements.



HSM

Selection & Specifications

Shaft Mounted Speed Reducers

Class I page 11

Class II page 23

Class III page 35

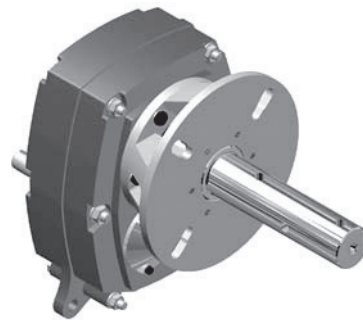
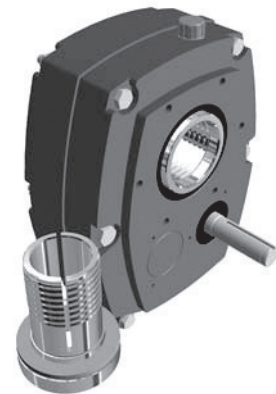

CEMA
Screw Conveyor Drives
Page 48

How to Select

How to select an HSM Speed Reducer



Step 1: Collect data about your application

Before starting you need to know the:

- **Application** (e.g. Conveyor, Mixer, etc.)
- **Hours of Operation per day**
- **Motor Horsepower (HP)**
- **Desired Output Speed**

Step 2: Find the Load Classification of your application

Use the **AGMA Load Classification Tables** on page 8, based on the application and number of working hours per day.

Step 3: Select an HSM Speed Reducer Unit Size

Refer to the **Speed Reducer Selection Tables** for your Classification (I, II or III). Select the **Unit Size** based on the application's Motor Horsepower (HP) and Output Speed (RPM). Determine the **Unit Size** and the **Nominal Ratio**.

Note: The selection table ratings are based on a starting load or momentary overload of:

- 2 times for Class I
- 2-3 times for Class II
- 4 times for Class III

If the application peak loads will exceed these values, select a Speed Reducer from the next higher class of service, or consult Sumitomo for exact Power Ratings data.

Step 4: Select a Bushing

Use the tables on the right to configure a Bushing model number.

How to select an CEMA Screw Conveyor Drive (Optional)

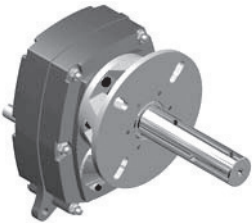

To select a **Screw Conveyor Drive Shaft Assembly** and **Mounting Adapter**, you will need to know the **Unit Size** (from Step 3 above) and the **Screw Diameter** for your application.

Refer to the **Screw Conveyor Selection Table** (page 48) to make this selection, and to determine the Shaft Diameter (for installation purposes).

How to select a Belt Drive (from third-party vendor)

Use this selection data to specify a Belt Drive from a belt drive vendor

Step 1: Calculate the Input Shaft Speed

Multiply the **Output Speed** by the **Exact Ratio**
(from page 53 or 55, based on Speed Reducer Size)

$$\text{Output Speed} \times \text{Exact Ratio} = \text{Input Shaft Speed} \quad \text{Example: } 48 \times 23.235 = 1211 \text{ RPM}$$

Step 2: Calculate the Belt Drive Ratio

Divide the **Motor Speed** by the **Input Shaft Speed**.

$$\text{Motor Speed} / \text{Input Shaft Speed} = \text{Belt Drive Ratio} \quad \text{Example: } 1750 / 1211 = 1.45:1$$

Step 3: Determine the Minimum Input Shaft Sheave Diameter

Refer to the **Sheave Diameter Table** on page 50. Based on the **HSM Speed Reducer Unit Size** selected, and the Output Speed RPM.

How to Select

Nomenclature

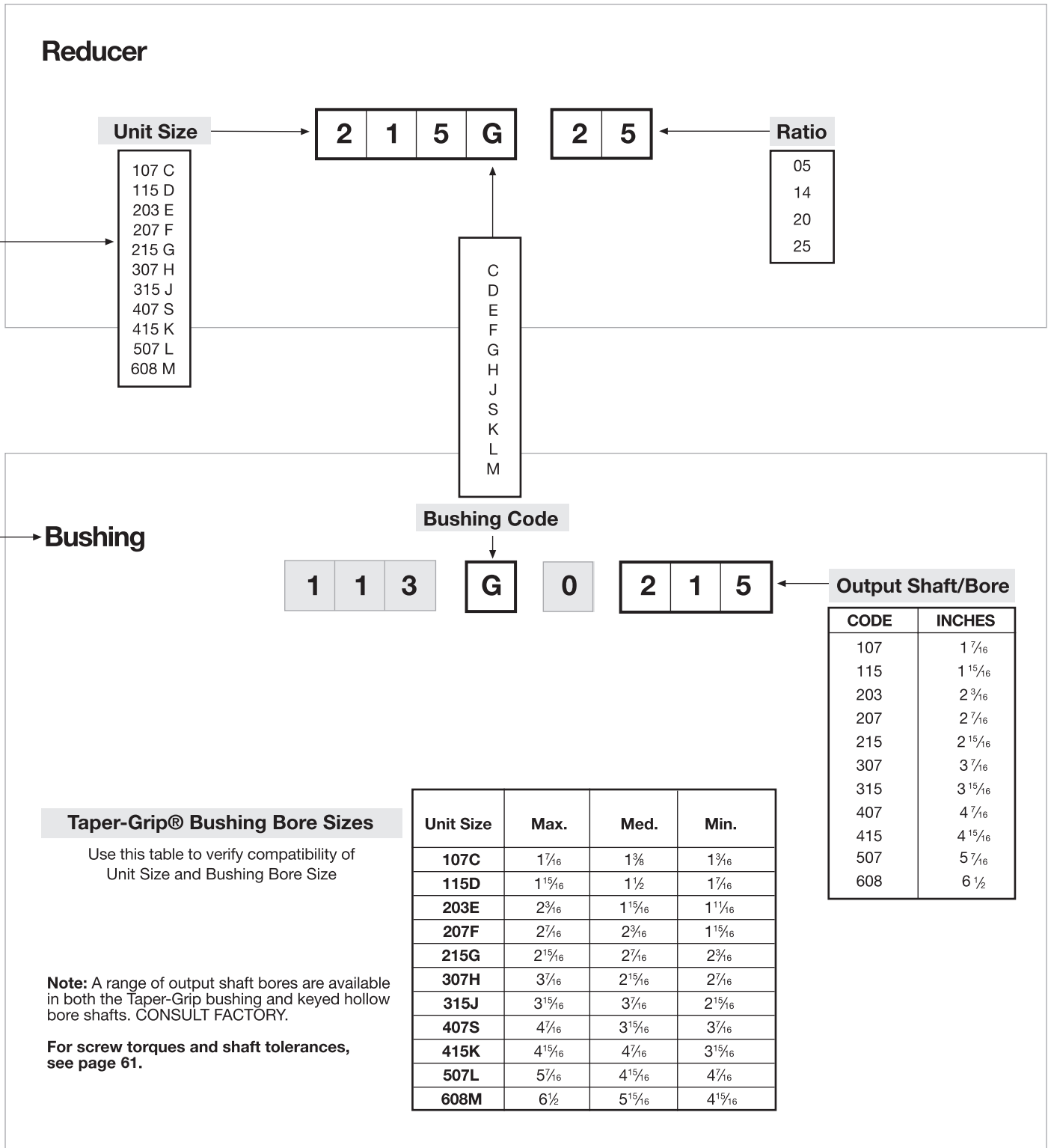

AGMA Load Classification Tables

APPLICATION	CLASS NUMBERS		
	Up to 3 Hrs per Day	3-10 Hrs per Day	Over 10 Hrs per Day
AGITATORS (Mixers)			
Pure Liquids	I	I	II
Liquids and Solids	I	II	II
Liquids – Variable Density	I	II	II
BLOWERS			
Centrifugal	I	I	II
Lobe	I	II	II
Vane	I	II	II
BREWING AND DISTILLING			
Bottling Machinery	I	I	II
Brew Kettles – Continuous Duty	II	II	II
Cookers – Continuous Duty	II	II	II
Mash Tubs – Continuous Duty	II	II	II
Scale Hopper – Frequent Starts	II	II	II
CAN FILLING MACHINES	I	I	II
CAR DUMPERS	I	III	III
CAR PULLERS	I	II	II
CLARIFIERS	I	I	II
CLASSIFIERS	I	II	II
CLAY WORKING MACHINERY			
Brick Press	II	III	III
Briquette Machine	II	III	III
Pug Mill	I	II	II
COMPACTORS	III	III	III
COMPRESSORS			
Centrifugal	I	I	II
Lobe	I	II	II
Reciprocating, Multi-Cylinder	II	II	III
Reciprocating, Single-Cylinder	III	III	III
CONVEYORS –			
GENERAL PURPOSE			
Includes Apron, Assembly, Belt, Bucket, Chain, Flight, Oven and Screw			
Uniformly Loaded or Fed	I	I	II
Heavy Duty – Not Uniformly Fed	I	II	II
Severe Duty – Reciprocating or Shaker	II	III	III
CRANES ^[1]			
Dry Dock			
Main Hoist	2.50	2.50	2.50
Auxiliary Hoist	2.50	2.50	3.00
Boom Hoist	2.50	2.50	3.00
Slewing Drive	2.50	2.50	3.00
Traction Drive	3.00	3.00	3.00
Container			
Main Hoist	3.00	3.00	3.00
Boom Hoist	2.00	2.00	2.00
Trolley Drive			
Gantry Drive	3.00	3.00	3.00
Traction Drive	2.00	2.00	2.00
Mill Duty			
Main Hoist	3.50	3.50	3.50
Auxiliary	3.50	3.50	3.50
Bridge	2.50	3.00	3.00
Trolley Travel	2.50	3.00	3.00
Industrial Duty			
Main	2.50	2.50	3.00
Auxiliary	2.50	2.50	3.00
Bridge	2.50	3.00	3.00
Trolley Travel	2.50	3.00	3.00

APPLICATION	CLASS NUMBERS		
	Up to 3 Hrs per Day	3-10 Hrs per Day	Over 10 Hrs per Day
CRUSHER			
Stone or Ore	III	III	III
DREDGES			
Cable Reels	II	II	II
Conveyors	II	II	II
Cutter Head Drives	III	III	III
Pumps	III	III	III
Screen Drives	III	III	III
Stackers	II	II	II
Winches	II	II	II
ELEVATORS			
Bucket	I	II	II
Centrifugal Discharge	I	I	II
Escalators	I	I	II
Freight	I	II	II
Gravity Discharge	I	I	II
EXTRUDERS			
General	II	II	II
Plastics			
Variable Speed Drive	III	III	III
Fixed Speed Drive	III	III	III
Rubber			
Continuous Screw Operation	III	III	III
Intermittent Screw Operation	III	III	III
FANS			
Centrifugal	I	I	II
Cooling Towers	III	III	III
Forced Draft	II	II	II
Induced Draft	II	II	II
Industrial & Mine	II	II	II
FEEDERS			
Apron	I	II	II
Belt	I	II	II
Disc	I	I	II
Reciprocating	II	III	III
Screw	I	II	II
FOOD INDUSTRY			
Cereal Cooker	I	I	II
Dough Mixer	II	II	II
Meat Grinders	II	II	II
Slicers	I	II	II
GENERATORS AND EXCITERS	II	II	II
HAMMER MILLS	III	III	III
HOISTS			
Heavy	III	III	III
Medium Duty	II	II	II
Skip Hoist	II	II	II
LAUNDRY TUMBLERS	II	II	II
LAUNDRY WASHERS	II	II	III

Note: [1] Because crane drive selections may require a service factor greater than 2.0, Class Numbers are not applicable. Crane drives are to be selected based upon the gear tooth bending strength using the numeric service factor shown in the table. In all cases, the pitting resistance service factor shall be a minimum of 1.0.

AGMA Load Classification Tables

APPLICATION	CLASS NUMBERS		
	Up to 3 Hrs per Day	3-10 Hrs per Day	Over 10 Hrs per Day
LUMBER INDUSTRY			
Barkers			
Spindle Feed	II	II	II
Main Drive	III	III	III
Conveyors			
Burner	II	II	II
Main or Heavy Duty	II	II	II
Main Log	III	III	III
Re-saw, Merry-Go-Round	II	II	II
Slab	III	III	III
Transfer	II	II	II
Chains			
Floor	II	II	II
Green	II	II	III
Cut-Off Saws			
Chain	II	II	III
Drag	II	II	III
Debarking Drums			
Feeds	III	III	III
Edger	II	II	II
Gang	III	III	III
Trimmer	II	II	II
Log Deck	III	III	III
Log Hauls – Incline – Well Type	III	III	III
Log Turning Devices	III	III	III
Planer Feed	II	II	II
Planer Tilting Hoists	II	II	II
Rolls – Live-off brg. – Roll Cases	III	III	III
Sorting Table	II	II	II
Tipple Hoist	II	II	II
Transfers			
Chain	II	II	III
Craneway	II	II	III
Tray Drives	II	II	II
Veneer Lathe Drives	II	II	II
METAL MILLS			
Draw Bench Carriage and Main Drive			
Main Drive	II	II	II
Runout Table			
Non-reversing			
Group Drives	II	II	II
Individual Drives	III	III	III
Reversing	III	III	III
Slab Pushers	II	II	II
Shears	III	III	III
Wire Drawing	II	II	II
Wire Winding Machine	II	II	II
METAL STRIP PROCESSING MACHINERY			
Bridles	II	II	II
Coilers & Uncoilers	I	I	II
Edge Trimmers	I	II	II
Flatteners	II	II	II
Loopers (Accumulators)	I	I	I
Pinch Rolls	II	II	II
Scrap Choppers	II	II	II
Shears	III	III	III
Slitters	I	II	II

APPLICATION	CLASS NUMBERS		
	Up to 3 Hrs per Day	3-10 Hrs per Day	Over 10 Hrs per Day
MILLS, ROTARY TYPE			
Ball & Rod			
Spur Ring Gear	III	III	III
Helical Ring Gear	II	II	II
Direct Connected	III	III	III
Cement Kilns	II	II	II
Dryers & Coolers	II	II	II
MIXERS, CEMENT			
	II	II	II
PAPER MILLS ^[1]			
Agitator (Mixer)	II	II	II
Agitator for Pure Liquors	II	II	II
Barking Drums	III	III	III
Barkers – Mechanical	III	III	III
Beater	II	II	II
Breaker Stack	II	II	II
Calender ^[1]	II	II	II
Chipper	III	III	III
Chip Feeder	II	II	II
Coating Rolls	II	II	II
Conveyors			
Chip, Bark, Chemical	II	II	II
Log (including Slab)	III	III	III
Couch Rolls	II	II	II
Cutter	III	III	III
Cylinder Molds	II	II	II
Dryers ^[1]			
Paper Machine	II	II	II
Conveyor Type	II	II	II
Embosses	II	II	II
Extruder	II	II	II
Fourdrinier Rolls			
(Includes Lump breaker, dandy roll, wire turning, and return rolls)	II	II	II
Jordan	II	II	II
Kiln Drive	II	II	II
Mt. Hope Roll	II	II	II
Paper Rolls	II	II	II
Platter	II	II	II
Presses – Felt & Suction	II	II	II
Pulper	III	III	III
Pumps – Vacuum	II	II	II
Reel (Surface Type)	II	II	II
Screens			
Chip	II	II	II
Rotary	II	II	II
Vibrating	III	III	III
Size Press	II	II	II
Supercalender ^[2]	II	II	II
Thickener (AC Motor)	II	II	II
(DC Motor)	II	II	II
Washer (AC Motor)	II	II	II
(DC Motor)	II	II	II
Wind and Unwind Stand	I	I	I
Winders (Surface Type)	II	II	II
Yankee Dryers ^[1]	II	II	II

Notes: [1] Anti-Friction Bearings only.

[2] A Class Number of I may be applied at base speed of a supercalender operating over a speed range of part-range constant horsepower and part-range constant torque where the constant horsepower speed range is greater than 1.5 to 1. A Class Number of II is applicable to supercalenders operating over the entire speed range at constant torque or where the constant horsepower speed range is less than 1.5 to 1.

AGMA Load Classification Tables

APPLICATION	CLASS NUMBERS		
	Up to 3 Hrs per Day	3-10 Hrs per Day	Over 10 Hrs per Day
PLASTIC INDUSTRY – PRIMARY PROCESSING			
Intensive Internal Mixers			
Batch Mixers	III	III	III
Continuous Mixers	II	II	II
Batch Drop Mill – 2 smooth rolls	II	II	II
Continuous Feed, Holding & Blend Mill	II	II	II
Calenders	II	II	II
PLASTIC INDUSTRY – SECOND PROCESSING			
Blow Molders	II	II	II
Coating	II	II	II
Film	II	II	II
Pipe	II	II	II
Pre-Plasticizers	II	II	II
Rods	II	II	II
Sheet	II	II	II
Tubing	II	II	II
PULLERS – BARGE HAUL	II	II	II
PUMPS			
Centrifugal	I	I	II
Proportioning	II	II	II
Reciprocating			
Single Acting, 3 or more cylinders	II	II	II
Double Acting, 2 or more cylinders	II	II	II
Rotary			
Gear Type	I	I	II
Lobe	I	I	II
Vane	I	I	II
RUBBER INDUSTRY			
Intensive Internal Mixers			
Batch Mixers	III	III	III
Continuous Mixers	II	II	II
Mixing Mill			
2 smooth rolls	II	II	II
1 or 2 corrugated rolls	III	III	III
Batch Drop Mill – 2 smooth rolls	II	II	II
Cracker Warmer –			
2 roll; 1 corrugated roll	III	III	III
Cracker – 2 corrugated rolls	III	III	III
Holding, Feed & Blend			
Mill – 2 rolls	II	II	II
Refiner – 2 rolls	II	II	II
Calenders	II	II	II
SAND MULLER	II	II	II

APPLICATION	CLASS NUMBERS		
	Up to 3 Hrs per Day	3-10 Hrs per Day	Over 10 Hrs per Day
SEWAGE DISPOSAL EQUIPMENT			
Bar Screens	II	II	II
Chemical Feeders	II	II	II
Dewatering Screens	II	II	II
Scum Breakers	II	II	II
Slow or Rapid Mixers	II	II	II
Sludge Collectors	II	II	II
Thickener	II	II	II
Vacuum Filters	II	II	II
SCREENS			
Air Washing	I	I	II
Rotary – Stone or Gravel	II	II	II
Traveling Water Intake	I	I	I
SCREW CONVEYORS			
Uniformly Loaded or Fed	I	I	II
Heavy Duty	I	II	II
SUGAR INDUSTRY			
Beet Slicer	III	III	III
Cane Knives	II	II	II
Crushers	II	II	II
Mills (low speed end)	III	III	III
TEXTILE INDUSTRY			
Batchers	II	II	II
Calenders	II	II	II
Cards	II	II	II
Dry Cans	II	II	II
Dyeing Machinery	II	II	II
Looms	II	II	II
Mangles	II	II	II
Nappers	II	II	II
Pads	II	II	II
Slashers	II	II	II
Soapers	II	II	II
Spinners	II	II	II
Tenter Frames	II	II	II
Washers	II	II	II
Winders	II	II	II

HSM Speed Reducer Selection (SF = 1.0) CLASS I

OUTPUT RPM	GEARBOX SIZE†	MIN INPUT SHAFT SHEAVE P.D. (in.)	COOLING METHOD
1/4 HP Motor			
10 - 11	HSM107C-25	1.4	—
	HSM107C-20	1.6	—
	HSM107C-14	2.4	—
	HSM107C-09	3.5	—
12 - 17	HSM107C-25	1.4	—
	HSM107C-20	1.6	—
	HSM107C-14	2.5	—
	HSM107C-09	3.5	—
18	HSM107C-25	1.5	—
	HSM107C-20	1.7	—
	HSM107C-14	2.5	—
	HSM107C-09	3.5	—
19 - 24	HSM107C-25	1.5	—
	HSM107C-20	1.7	—
	HSM107C-14	2.6	—
	HSM107C-09	3.5	—
25 - 26	HSM107C-25	1.6	—
	HSM107C-20	1.7	—
	HSM107C-14	2.6	—
	HSM107C-09	3.4	—
27 - 36	HSM107C-25	1.6	—
	HSM107C-20	1.8	—
	HSM107C-14	2.6	—
	HSM107C-09	3.4	—
37	HSM107C-25	1.8	—
	HSM107C-20	1.9	—
	HSM107C-14	2.5	—
	HSM107C-09	3.4	—
38	HSM107C-25	1.8	—
	HSM107C-20	1.9	—
	HSM107C-14	2.5	—
	HSM107C-09	3.3	—
39	HSM107C-25	1.8	—
	HSM107C-20	1.9	—
	HSM107C-14	2.6	—
	HSM107C-09	3.3	—
40 - 65	HSM107C-25	1.8	—
	HSM107C-20	2.0	—
	HSM107C-14	2.6	—
	HSM107C-09	3.3	—
66 - 68	HSM107C-25	1.9	—
	HSM107C-20	2.0	—
	HSM107C-14	2.7	—
	HSM107C-09	3.3	—
69 - 70	HSM107C-25	1.9	—
	HSM107C-20	2.0	—
	HSM107C-14	2.7	—
	HSM107C-09	3.4	—
71 - 74	HSM107C-25	1.9	—
	HSM107C-20	2.1	—
	HSM107C-14	2.7	—
	HSM107C-09	3.4	—
75	HSM107C-25	1.9	—
	HSM107C-20	2.1	—
	HSM107C-14	2.8	—
	HSM107C-09	3.5	—
76	HSM107C-25	2.0	—
	HSM107C-20	2.1	—
	HSM107C-14	2.8	—
	HSM107C-09	3.4	—
77 - 79	HSM107C-25	2.0	—
	HSM107C-20	2.2	—
	HSM107C-14	2.6	—
	HSM107C-09	3.3	—
66 - 68	HSM107C-25	1.9	—
	HSM107C-20	2.0	—
	HSM107C-14	2.7	—
	HSM107C-09	3.3	—
69 - 70	HSM107C-25	1.9	—
	HSM107C-20	2.0	—
	HSM107C-14	2.7	—
	HSM107C-09	3.4	—
71 - 74	HSM107C-25	1.9	—
	HSM107C-20	2.1	—
	HSM107C-14	2.7	—
	HSM107C-09	3.4	—
75	HSM107C-25	1.9	—
	HSM107C-20	2.1	—
	HSM107C-14	2.8	—
	HSM107C-09	3.5	—
76	HSM107C-25	2.0	—
	HSM107C-20	2.1	—
	HSM107C-14	2.8	—
	HSM107C-09	3.4	—
77 - 79	HSM107C-25	2.0	—
	HSM107C-20	2.2	—
	HSM107C-14	2.6	—
	HSM107C-09	3.3	—

OUTPUT RPM	GEARBOX SIZE†	MIN INPUT SHAFT SHEAVE P.D. (in.)	COOLING METHOD
1/4 HP Motor (cont.)			
	HSM107C-14	2.8	—
	HSM107C-09	3.4	—
80	HSM107C-25	2.0	—
	HSM107C-20	2.2	—
	HSM107C-14	2.9	—
	HSM107C-09	3.4	—
81 - 83	HSM107C-25	2.0	—
	HSM107C-20	2.2	—
	HSM107C-14	2.9	—
	HSM107C-09	3.5	—
84 - 86	HSM107C-25	2.1	—
	HSM107C-20	2.2	—
	HSM107C-14	2.9	—
	HSM107C-09	3.5	—
87 - 90	HSM107C-20	2.3	—
	HSM107C-14	2.9	—
	HSM107C-09	3.5	—
91 - 93	HSM107C-20	2.3	—
	HSM107C-14	3.0	—
	HSM107C-09	3.5	—
94 - 97	HSM107C-20	2.3	—
	HSM107C-14	3.0	—
	HSM107C-09	3.6	—
98 - 99	HSM107C-20	2.3	—
	HSM107C-14	2.9	—
	HSM107C-09	3.7	—
100	HSM107C-14	2.9	—
	HSM107C-09	3.7	—
	HSM107C-05	5.6	—
101 - 102	HSM107C-09	3.7	—
	HSM107C-05	5.5	—
103 - 116	HSM107C-09	3.6	—
	HSM107C-05	5.5	—
117 - 220	HSM107C-09	3.6	—
	HSM107C-05	5.3	—
221 - 328	HSM107C-05	5.2	—
329 - 400	HSM107C-05	5.4	—
1/3 HP Motor			
10 - 11	HSM107C-25	1.4	—
	HSM107C-20	1.6	—
	HSM107C-14	2.4	—
	HSM107C-09	3.5	—
12 - 17	HSM107C-25	1.4	—
	HSM107C-20	1.6	—
	HSM107C-14	2.5	—
	HSM107C-09	3.5	—
18	HSM107C-25	1.5	—
	HSM107C-20	1.7	—
	HSM107C-14	2.5	—
	HSM107C-09	3.5	—
19 - 24	HSM107C-25	1.5	—
	HSM107C-20	1.7	—
	HSM107C-14	2.6	—
	HSM107C-09	3.5	—
25 - 26	HSM107C-25	1.6	—
	HSM107C-20	1.7	—
	HSM107C-14	2.6	—
	HSM107C-09	3.4	—
27 - 36	HSM107C-25	1.6	—
	HSM107C-20	1.8	—
	HSM107C-14	2.6	—
	HSM107C-09	3.4	—

OUTPUT RPM	GEARBOX SIZE†	MIN INPUT SHAFT SHEAVE P.D. (in.)	COOLING METHOD
1/3 HP Motor (cont.)			
37	HSM107C-25	1.8	—
	HSM107C-20	1.9	—
	HSM107C-14	2.5	—
	HSM107C-09	3.4	—
38	HSM107C-25	1.8	—
	HSM107C-20	1.9	—
	HSM107C-14	2.5	—
	HSM107C-09	3.3	—
39	HSM107C-25	1.8	—
	HSM107C-20	1.9	—
	HSM107C-14	2.6	—
	HSM107C-09	3.3	—
40 - 65	HSM107C-25	1.8	—
	HSM107C-20	2.0	—
	HSM107C-14	2.6	—
	HSM107C-09	3.3	—
66 - 68	HSM107C-25	1.9	—
	HSM107C-20	2.0	—
	HSM107C-14	2.7	—
	HSM107C-09	3.3	—
69 - 70	HSM107C-25	1.9	—
	HSM107C-20	2.0	—
	HSM107C-14	2.7	—
	HSM107C-09	3.4	—
71 - 74	HSM107C-25	1.9	—
	HSM107C-20	2.1	—
	HSM107C-14	2.7	—
	HSM107C-09	3.4	—
75	HSM107C-25	1.9	—
	HSM107C-20	2.1	—
	HSM107C-14	2.8	—
	HSM107C-09	3.5	—
76	HSM107C-25	2.0	—
	HSM107C-20	2.1	—
	HSM107C-14	2.8	—
	HSM107C-09	3.4	—
77 - 79	HSM107C-25	2.0	—
	HSM107C-20	2.2	—
	HSM107C-14	2.8	—
	HSM107C-09	3.4	—
80	HSM107C-25	2.0	—
	HSM107C-20	2.2	—
	HSM107C-14	2.9	—
	HSM107C-09	3.4	—
81 - 83	HSM107C-25	2.0	—
	HSM107C-20	2.2	—
	HSM107C-14	2.9	—
	HSM107C-09	3.5	—
84 - 86	HSM107C-25	2.1	—
	HSM107C-20	2.2	—
	HSM107C-14	2.9	—
	HSM107C-09	3.5	—
87 - 90	HSM107C-20	2.3	—
	HSM107C-14	2.9	—
	HSM107C-09	3.5	—
91 - 93	HSM107C-20	2.3	—
	HSM107C-14	3.0	—
	HSM107C-09	3.6	—
94 - 97	HSM107C-20	2.3	—
	HSM107C-14	3.0	—
	HSM107C-09	3.6	—
98 - 99	HSM107C-20	2.3	—
	HSM107C-14	2.9	—
	HSM107C-09	3.7	—

NOTE: †Consult factory for delivery of units with 9:1 and 20:1 ratios.

CLASS I HSM Speed Reducer Selection (SF = 1.0)

OUTPUT RPM	GEARBOX SIZE†	MIN INPUT SHAFT SHEAVE P.D. (in.)	COOLING METHOD
1/3 HP Motor (cont.)			
100	HSM107C-14	2.9	—
	HSM107C-09	3.7	—
	HSM107C-14	2.9	—
	HSM107C-09	3.7	—
101 - 102	HSM107C-05	5.6	—
	HSM107C-09	3.7	—
103 - 116	HSM107C-05	5.5	—
	HSM107C-09	3.6	—
117 - 220	HSM107C-05	5.5	—
	HSM107C-09	3.6	—
221 - 328	HSM107C-05	5.3	—
	HSM107C-09	5.2	—
329 - 400	HSM107C-05	5.4	—
1/2 HP Motor			
10 - 11	HSM107C-25	1.4	—
	HSM107C-20	1.6	—
	HSM107C-14	2.4	—
12 - 17	HSM107C-09	3.5	—
	HSM107C-25	1.4	—
	HSM107C-20	1.6	—
18	HSM107C-14	2.5	—
	HSM107C-09	3.5	—
	HSM107C-25	1.5	—
19 - 24	HSM107C-20	1.7	—
	HSM107C-14	2.5	—
	HSM107C-09	3.5	—
25 - 26	HSM107C-25	1.5	—
	HSM107C-20	1.7	—
	HSM107C-14	2.6	—
27 - 36	HSM107C-09	3.5	—
	HSM107C-25	1.6	—
	HSM107C-20	1.8	—
37	HSM107C-14	2.6	—
	HSM107C-09	3.4	—
	HSM107C-25	1.8	—
38	HSM107C-20	1.9	—
	HSM107C-14	2.5	—
	HSM107C-09	3.3	—
39	HSM107C-25	1.8	—
	HSM107C-20	1.9	—
	HSM107C-14	2.6	—
40 - 65	HSM107C-09	3.3	—
	HSM107C-25	1.8	—
	HSM107C-20	2.0	—
66 - 68	HSM107C-14	2.6	—
	HSM107C-09	3.3	—
	HSM107C-25	1.9	—
69 - 70	HSM107C-20	2.0	—
	HSM107C-14	2.7	—
	HSM107C-09	3.3	—

OUTPUT RPM	GEARBOX SIZE†	MIN INPUT SHAFT SHEAVE P.D. (in.)	COOLING METHOD
1/2 HP Motor (cont.)			
71 - 74	HSM107C-25	1.9	—
	HSM107C-20	2.1	—
	HSM107C-14	2.7	—
75	HSM107C-09	3.4	—
	HSM107C-25	1.9	—
	HSM107C-20	2.1	—
76	HSM107C-14	2.8	—
	HSM107C-09	3.5	—
	HSM107C-25	2.0	—
77 - 79	HSM107C-20	2.1	—
	HSM107C-14	2.8	—
	HSM107C-09	3.4	—
80	HSM107C-25	2.0	—
	HSM107C-20	2.2	—
	HSM107C-14	2.9	—
81 - 83	HSM107C-09	3.4	—
	HSM107C-25	2.0	—
	HSM107C-20	2.2	—
84 - 86	HSM107C-14	2.9	—
	HSM107C-09	3.5	—
	HSM107C-25	2.1	—
87 - 90	HSM107C-20	2.2	—
	HSM107C-14	2.9	—
	HSM107C-09	3.5	—
91 - 93	HSM107C-20	2.3	—
	HSM107C-14	2.9	—
	HSM107C-09	3.5	—
94 - 97	HSM107C-20	2.3	—
	HSM107C-14	3.0	—
	HSM107C-09	3.5	—
98 - 99	HSM107C-20	2.3	—
	HSM107C-14	2.9	—
	HSM107C-09	3.7	—
100	HSM107C-20	2.9	—
	HSM107C-14	3.7	—
	HSM107C-05	5.6	—
101 - 102	HSM107C-09	3.7	—
	HSM107C-05	5.5	—
103 - 116	HSM107C-09	3.6	—
	HSM107C-05	5.5	—
117 - 220	HSM107C-09	3.6	—
	HSM107C-05	5.3	—
221 - 328	HSM107C-05	5.2	—
	HSM107C-05	5.4	—
3/4 HP Motor			
10	HSM115D-25	1.9	—
	HSM115D-20	2.1	—
	HSM115D-14	3.2	—
11	HSM115D-09	4.9	—
	HSM107C-25	1.4	—
	HSM107C-20	1.6	—
12 - 17	HSM107C-14	2.4	—
	HSM107C-09	3.5	—
	HSM107C-25	1.4	—
12 - 17	HSM107C-25	1.4	—
	HSM107C-20	1.6	—

OUTPUT RPM	GEARBOX SIZE†	MIN INPUT SHAFT SHEAVE P.D. (in.)	COOLING METHOD
3/4 HP Motor (cont.)			
18	HSM107C-14	2.5	—
	HSM107C-09	3.5	—
	HSM107C-25	1.5	—
19 - 24	HSM107C-20	1.7	—
	HSM107C-14	2.5	—
	HSM107C-09	3.5	—
25 - 26	HSM107C-25	1.5	—
	HSM107C-20	1.7	—
	HSM107C-14	2.6	—
27 - 36	HSM107C-09	3.5	—
	HSM107C-25	1.6	—
	HSM107C-20	1.8	—
37	HSM107C-20	1.8	—
	HSM107C-09	3.4	—
	HSM107C-25	1.9	—
38	HSM107C-20	1.9	—
	HSM107C-14	2.5	—
	HSM107C-09	3.4	—
39	HSM107C-25	1.8	—
	HSM107C-20	1.9	—
	HSM107C-14	2.5	—
40 - 65	HSM107C-09	3.3	—
	HSM107C-25	1.8	—
	HSM107C-20	2.0	—
66 - 68	HSM107C-14	2.6	—
	HSM107C-09	3.3	—
	HSM107C-25	1.9	—
69 - 70	HSM107C-20	2.0	—
	HSM107C-14	2.7	—
	HSM107C-09	3.3	—
71 - 74	HSM107C-25	1.9	—
	HSM107C-20	2.1	—
	HSM107C-14	2.7	—
75	HSM107C-09	3.4	—
	HSM107C-25	1.9	—
	HSM107C-20	2.1	—
76	HSM107C-14	2.8	—
	HSM107C-09	3.4	—
	HSM107C-25	2.0	—
77 - 79	HSM107C-20	2.2	—
	HSM107C-14	2.8	—
	HSM107C-09	3.4	—
80	HSM107C-25	2.0	—
	HSM107C-20	2.2	—
	HSM107C-14	2.9	—
80	HSM107C-09	3.4	—
	HSM107C-25	2.0	—
	HSM107C-20	2.2	—

NOTE: †Consult factory for delivery of units with 9:1 and 20:1 ratios.

HSM Speed Reducer Selection (SF = 1.0) CLASS I

OUTPUT RPM	GEARBOX SIZE†	MIN INPUT SHAFT SHEAVE P.D. (in.)	COOLING METHOD
3/4 HP Motor (cont.)			
81 - 83	HSM107C-25	2.0	—
	HSM107C-20	2.2	—
	HSM107C-14	2.9	—
	HSM107C-09	3.5	—
84 - 86	HSM107C-25	2.1	—
	HSM107C-20	2.2	—
	HSM107C-14	2.9	—
	HSM107C-09	3.5	—
87 - 90	HSM107C-20	2.3	—
	HSM107C-14	2.9	—
	HSM107C-09	3.5	—
91 - 93	HSM107C-20	2.3	—
	HSM107C-14	3.0	—
	HSM107C-09	3.5	—
94 - 97	HSM107C-20	2.3	—
	HSM107C-14	3.0	—
	HSM107C-09	3.6	—
98 - 99	HSM107C-20	2.3	—
	HSM107C-14	2.9	—
	HSM107C-09	3.7	—
100	HSM107C-14	2.9	—
	HSM107C-09	3.7	—
	HSM107C-05	5.6	—
101 - 102	HSM107C-09	3.7	—
	HSM107C-05	5.5	—
103 - 116	HSM107C-09	3.6	—
	HSM107C-05	5.5	—
117 - 220	HSM107C-09	3.6	—
	HSM107C-05	5.3	—
221 - 328	HSM107C-05	5.2	—
329 - 400	HSM107C-05	5.4	—
1 HP Motor			
10	HSM115D-25	1.9	—
	HSM115D-20	2.1	—
	HSM115D-14	3.2	—
	HSM115D-09	4.9	—
11 - 13	HSM115D-25	1.9	—
	HSM115D-20	2.2	—
	HSM115D-14	3.3	—
	HSM115D-09	5.0	—
14 - 17	HSM107C-25	1.4	—
	HSM107C-20	1.6	—
	HSM107C-14	2.5	—
	HSM107C-09	3.5	—
18	HSM107C-25	1.5	—
	HSM107C-20	1.7	—
	HSM107C-14	2.5	—
	HSM107C-09	3.5	—
19 - 24	HSM107C-25	1.5	—
	HSM107C-20	1.7	—
	HSM107C-14	2.6	—
	HSM107C-09	3.5	—
25 - 26	HSM107C-25	1.6	—
	HSM107C-20	1.7	—
	HSM107C-14	2.6	—
	HSM107C-09	3.4	—
27 - 36	HSM107C-25	1.6	—
	HSM107C-20	1.8	—
	HSM107C-14	2.6	—
	HSM107C-09	3.4	—
37	HSM107C-25	1.8	—
	HSM107C-20	1.9	—
	HSM107C-14	2.9	—
	HSM107C-09	3.7	—

OUTPUT RPM	GEARBOX SIZE†	MIN INPUT SHAFT SHEAVE P.D. (in.)	COOLING METHOD
1 HP Motor (cont.)			
	HSM107C-14	2.5	—
	HSM107C-09	3.4	—
38	HSM107C-25	1.8	—
	HSM107C-20	1.9	—
	HSM107C-14	2.5	—
	HSM107C-09	3.3	—
39	HSM107C-25	1.8	—
	HSM107C-20	1.9	—
	HSM107C-14	2.6	—
	HSM107C-09	3.3	—
40 - 65	HSM107C-25	1.8	—
	HSM107C-20	2.0	—
	HSM107C-14	2.6	—
	HSM107C-09	3.3	—
66 - 68	HSM107C-25	1.9	—
	HSM107C-20	2.0	—
	HSM107C-14	2.7	—
	HSM107C-09	3.3	—
69 - 70	HSM107C-25	1.9	—
	HSM107C-20	2.0	—
	HSM107C-14	2.7	—
	HSM107C-09	3.4	—
71 - 74	HSM107C-25	1.9	—
	HSM107C-20	2.1	—
	HSM107C-14	2.7	—
	HSM107C-09	3.4	—
75	HSM107C-25	1.9	—
	HSM107C-20	2.1	—
	HSM107C-14	2.8	—
	HSM107C-09	3.5	—
76	HSM107C-25	2.0	—
	HSM107C-20	2.1	—
	HSM107C-14	2.8	—
	HSM107C-09	3.4	—
77 - 79	HSM107C-25	2.0	—
	HSM107C-20	2.2	—
	HSM107C-14	2.8	—
	HSM107C-09	3.4	—
80	HSM107C-25	2.0	—
	HSM107C-20	2.2	—
	HSM107C-14	2.9	—
	HSM107C-09	3.4	—
81 - 83	HSM107C-25	2.0	—
	HSM107C-20	2.2	—
	HSM107C-14	2.9	—
	HSM107C-09	3.5	—
84 - 86	HSM107C-25	2.1	—
	HSM107C-20	2.2	—
	HSM107C-14	2.9	—
	HSM107C-09	3.5	—
87 - 90	HSM107C-20	2.3	—
	HSM107C-14	2.9	—
	HSM107C-09	3.5	—
91 - 93	HSM107C-20	2.3	—
	HSM107C-14	3.0	—
	HSM107C-09	3.5	—
94 - 97	HSM107C-20	2.3	—
	HSM107C-14	3.0	—
	HSM107C-09	3.6	—
98 - 99	HSM107C-20	2.3	—
	HSM107C-14	2.9	—
	HSM107C-09	3.7	—

OUTPUT RPM	GEARBOX SIZE†	MIN INPUT SHAFT SHEAVE P.D. (in.)	COOLING METHOD
1 HP Motor (cont.)			
100	HSM107C-14	2.9	—
	HSM107C-09	3.7	—
	HSM107C-05	5.6	—
101 - 102	HSM107C-09	3.7	—
	HSM107C-05	5.5	—
103 - 116	HSM107C-09	3.6	—
	HSM107C-05	5.5	—
117 - 220	HSM107C-09	3.6	—
	HSM107C-05	5.3	—
221 - 328	HSM107C-05	5.2	—
329 - 400	HSM107C-05	5.4	—
1 1/2 HP Motor			
10	HSM203E-25	2.1	—
	HSM203E-20	2.5	—
	HSM203E-14	3.8	—
	HSM203E-09	5.7	—
11 - 12	HSM203E-25	2.1	—
	HSM203E-20	2.6	—
	HSM203E-14	3.9	—
	HSM203E-09	5.7	—
13 - 14	HSM115D-25	1.9	—
	HSM115D-20	2.2	—
	HSM115D-14	3.3	—
	HSM115D-09	5.0	—
15	HSM115D-25	1.9	—
	HSM115D-20	2.2	—
	HSM115D-14	3.4	—
	HSM115D-09	5.1	—
16	HSM115D-25	2.0	—
	HSM115D-20	2.3	—
	HSM115D-14	3.4	—
	HSM115D-09	5.1	—
17 - 19	HSM115D-25	2.0	—
	HSM115D-20	2.3	—
	HSM115D-14	3.4	—
	HSM115D-09	5.2	—
20 - 21	HSM107C-25	1.5	—
	HSM107C-20	1.7	—
	HSM107C-14	2.6	—
	HSM115D-09	5.2	—
22 - 24	HSM107C-25	1.5	—
	HSM107C-20	1.7	—
	HSM107C-14	2.6	—
	HSM107C-09	3.5	—
25 - 26	HSM107C-25	1.6	—
	HSM107C-20	1.7	—
	HSM107C-14	2.6	—
	HSM107C-09	3.4	—
27 - 36	HSM107C-25	1.6	—
	HSM107C-20	1.8	—
	HSM107C-14	2.6	—
	HSM107C-09	3.4	—
37	HSM107C-25	1.8	—
	HSM107C-20	1.9	—
	HSM107C-14	2.5	—
	HSM107C-09	3.4	—
38	HSM107C-25	1.8	—
	HSM107C-20	1.9	—
	HSM107C-14	2.5	—
	HSM107C-09	3.3	—
39	HSM107C-25	1.8	—
	HSM107C-20	1.9	—

NOTE: †Consult factory for delivery of units with 9:1 and 20:1 ratios.

CLASS I HSM Speed Reducer Selection (SF = 1.0)

OUTPUT RPM	GEARBOX SIZE†	MIN INPUT SHAFT SHEAVE P.D. (in.)	COOLING METHOD
1 1/2 HP Motor (cont.)			
40 - 65	HSM107C-14	2.6	—
	HSM107C-09	3.3	—
	HSM107C-25	1.8	—
	HSM107C-20	2.0	—
	HSM107C-14	2.6	—
66 - 68	HSM107C-09	3.3	—
	HSM107C-25	1.9	—
	HSM107C-20	2.0	—
	HSM107C-14	2.7	—
69 - 70	HSM107C-09	3.3	—
	HSM107C-25	1.9	—
	HSM107C-20	2.0	—
	HSM107C-14	2.7	—
71 - 74	HSM107C-09	3.4	—
	HSM107C-25	1.9	—
	HSM107C-20	2.1	—
	HSM107C-14	2.7	—
75	HSM107C-09	3.4	—
	HSM107C-25	1.9	—
	HSM107C-20	2.1	—
	HSM107C-14	2.8	—
76	HSM107C-09	3.5	—
	HSM107C-25	2.0	—
	HSM107C-20	2.1	—
	HSM107C-14	2.8	—
77 - 79	HSM107C-09	3.4	—
	HSM107C-25	2.0	—
	HSM107C-20	2.2	—
	HSM107C-14	2.8	—
80	HSM107C-09	3.4	—
	HSM107C-25	2.0	—
	HSM107C-20	2.2	—
	HSM107C-14	2.9	—
81 - 83	HSM107C-09	3.4	—
	HSM107C-25	2.0	—
	HSM107C-20	2.2	—
	HSM107C-14	2.9	—
84 - 86	HSM107C-09	3.5	—
	HSM107C-25	2.1	—
	HSM107C-20	2.2	—
	HSM107C-14	2.9	—
87 - 90	HSM107C-09	3.5	—
	HSM107C-25	2.3	—
	HSM107C-14	2.9	—
91 - 93	HSM107C-09	3.5	—
	HSM107C-25	2.3	—
	HSM107C-14	3.0	—
94 - 97	HSM107C-09	3.5	—
	HSM107C-25	2.3	—
	HSM107C-14	3.0	—
98 - 99	HSM107C-09	3.6	—
	HSM107C-25	2.3	—
	HSM107C-14	2.9	—
100	HSM107C-09	3.7	—
	HSM107C-25	2.3	—
	HSM107C-14	3.0	—
101 - 102	HSM107C-09	3.5	—
	HSM107C-25	2.3	—
	HSM107C-14	3.0	—
103 - 116	HSM107C-09	3.6	—
	HSM107C-25	2.3	—
	HSM107C-14	2.9	—
117 - 220	HSM107C-09	3.7	—
	HSM107C-25	2.3	—
	HSM107C-14	3.6	—

OUTPUT RPM	GEARBOX SIZE†	MIN INPUT SHAFT SHEAVE P.D. (in.)	COOLING METHOD
1 1/2 HP Motor (cont.)			
221 - 328	HSM107C-05	5.3	—
329 - 400	HSM107C-05	5.2	—
	HSM107C-05	5.4	—
2 HP Motor			
10 - 11	HSM207F-25	1.6	—
	HSM207F-20	2.0	—
	HSM207F-14	3.0	—
12 - 14	HSM203E-25	2.1	—
	HSM203E-20	2.6	—
	HSM203E-14	3.9	—
	HSM203E-09	5.8	—
15	HSM203E-25	2.1	—
	HSM203E-20	2.6	—
	HSM203E-14	4.0	—
	HSM203E-09	5.8	—
16	HSM203E-25	2.1	—
	HSM203E-20	2.7	—
	HSM203E-14	4.0	—
	HSM203E-09	5.8	—
17 - 19	HSM115D-25	2.0	—
	HSM115D-20	2.3	—
	HSM115D-14	3.4	—
	HSM115D-09	5.2	—
20 - 22	HSM115D-25	2.0	—
	HSM115D-20	2.3	—
	HSM115D-14	3.5	—
	HSM115D-09	5.2	—
23 - 25	HSM115D-25	2.1	—
	HSM115D-20	2.3	—
	HSM115D-14	3.5	—
	HSM115D-09	5.3	—
26	HSM107C-25	1.6	—
	HSM107C-20	1.7	—
	HSM107C-14	2.6	—
	HSM115D-09	5.3	—
27 - 28	HSM107C-25	1.6	—
	HSM107C-20	1.8	—
	HSM107C-14	2.6	—
	HSM115D-09	5.3	—
29 - 36	HSM107C-25	1.7	—
	HSM107C-20	1.8	—
	HSM107C-14	2.6	—
	HSM107C-09	3.4	—
37	HSM107C-25	1.8	—
	HSM107C-20	1.9	—
	HSM107C-14	2.5	—
	HSM107C-09	3.4	—
38	HSM107C-25	1.8	—
	HSM107C-20	1.9	—
	HSM107C-14	2.5	—
	HSM107C-09	3.3	—
39	HSM107C-25	1.8	—
	HSM107C-20	1.9	—
	HSM107C-14	2.6	—
	HSM107C-09	3.3	—
40 - 65	HSM107C-25	1.8	—
	HSM107C-20	2.0	—
	HSM107C-14	2.6	—
	HSM107C-09	3.3	—
66 - 68	HSM107C-25	1.9	—
	HSM107C-20	2.0	—
	HSM107C-14	2.7	—

OUTPUT RPM	GEARBOX SIZE†	MIN INPUT SHAFT SHEAVE P.D. (in.)	COOLING METHOD
2 HP Motor (cont.)			
69 - 70	HSM107C-09	3.3	—
	HSM107C-25	1.9	—
	HSM107C-20	2.0	—
	HSM107C-14	2.7	—
71 - 74	HSM107C-09	3.4	—
	HSM107C-25	1.9	—
	HSM107C-20	2.1	—
	HSM107C-14	2.7	—
75	HSM107C-09	3.4	—
	HSM107C-25	1.9	—
	HSM107C-20	2.1	—
	HSM107C-14	2.8	—
	HSM107C-09	3.5	—
76	HSM107C-25	2.0	—
	HSM107C-20	2.1	—
	HSM107C-14	2.8	—
	HSM107C-09	3.4	—
77 - 79	HSM107C-25	2.0	—
	HSM107C-20	2.2	—
	HSM107C-14	2.8	—
	HSM107C-09	3.4	—
80	HSM107C-25	2.0	—
	HSM107C-20	2.2	—
	HSM107C-14	2.9	—
81 - 83	HSM107C-09	3.4	—
	HSM107C-25	2.0	—
	HSM107C-20	2.2	—
	HSM107C-14	2.9	—
	HSM107C-09	3.5	—
84 - 86	HSM107C-25	2.1	—
	HSM107C-20	2.2	—
	HSM107C-14	2.9	—
	HSM107C-09	3.5	—
87 - 90	HSM107C-25	2.1	—
	HSM107C-20	2.3	—
	HSM107C-14	2.9	—
	HSM107C-09	3.5	—
91 - 93	HSM107C-25	2.3	—
	HSM107C-20	2.3	—
	HSM107C-14	3.0	—
	HSM107C-09	3.5	—
94 - 97	HSM107C-25	2.3	—
	HSM107C-20	2.3	—
	HSM107C-14	3.0	—
	HSM107C-09	3.6	—
98 - 99	HSM107C-25	2.3	—
	HSM107C-20	2.3	—
	HSM107C-14	2.9	—
	HSM107C-09	3.7	—
100	HSM107C-25	2.3	—
	HSM107C-14	2.9	—
	HSM107C-09	3.7	—
	HSM107C-05	5.6	—
101 - 102	HSM107C-09	3.7	—
	HSM107C-05	5.5	—
103 - 116	HSM107C-09	3.6	—
	HSM107C-05	5.5	—
117 - 220	HSM107C-09	3.6	—
	HSM107C-05	5.3	—
221 - 328	HSM107C-05	5.2	—
329 - 400	HSM107C-05	5.4	—
3 HP Motor			
10	HSM215G-25	2.3	—
	HSM215G-20	2.8	—
	HSM215G-14	4.3	—
11	HSM215G-25	2.3	—
	HSM215G-20	2.9	—

NOTE: †Consult factory for delivery of units with 9:1 and 20:1 ratios.

HSM Speed Reducer Selection (SF = 1.0) CLASS I

OUTPUT RPM	GEARBOX SIZE†	MIN INPUT SHAFT SHEAVE P.D. (in.)	COOLING METHOD
3 HP Motor (cont.)			
12	HSM215G-14	4.4	—
	HSM207F-25	1.6	—
	HSM207F-20	2.0	—
	HSM207F-14	3.0	—
13	HSM207F-25	1.7	—
	HSM207F-20	2.0	—
	HSM207F-14	3.1	—
14 - 15	HSM207F-25	1.7	—
	HSM207F-20	2.1	—
	HSM207F-14	3.1	—
16	HSM203E-25	2.1	—
	HSM203E-20	2.7	—
	HSM203E-14	4.0	—
17 - 24	HSM203E-25	2.2	—
	HSM203E-20	2.7	—
	HSM203E-14	4.0	—
	HSM203E-09	5.8	—
25	HSM115D-25	2.1	—
	HSM115D-20	2.3	—
	HSM115D-14	3.5	—
	HSM115D-09	5.3	—
26 - 28	HSM115D-25	2.2	—
	HSM115D-20	2.4	—
	HSM115D-14	3.5	—
	HSM115D-09	5.3	—
29 - 33	HSM115D-25	2.3	—
	HSM115D-20	2.5	—
	HSM115D-14	3.5	—
	HSM115D-09	5.3	—
34	HSM115D-25	2.4	—
	HSM115D-20	2.6	—
	HSM115D-14	3.5	—
	HSM115D-09	5.2	—
35 - 38	HSM115D-25	2.4	—
	HSM115D-20	2.6	—
	HSM115D-14	3.4	—
	HSM115D-09	5.2	—
39	HSM115D-25	2.4	—
	HSM115D-20	2.7	—
	HSM115D-14	3.4	—
	HSM115D-09	5.1	—
40 - 44	HSM107C-25	1.8	—
	HSM107C-20	2.0	—
	HSM107C-14	2.6	—
	HSM115D-09	5.1	—
45 - 65	HSM107C-25	1.8	—
	HSM107C-20	2.0	—
	HSM107C-14	2.6	—
	HSM107C-09	3.3	—
66 - 68	HSM107C-25	1.9	—
	HSM107C-20	2.0	—
	HSM107C-14	2.7	—
	HSM107C-09	3.3	—
69 - 70	HSM107C-25	1.9	—
	HSM107C-20	2.0	—
	HSM107C-14	2.7	—
	HSM107C-09	3.4	—
71 - 74	HSM107C-25	1.9	—
	HSM107C-20	2.1	—
	HSM107C-14	2.7	—
	HSM107C-09	3.4	—
75	HSM107C-25	1.9	—

OUTPUT RPM	GEARBOX SIZE†	MIN INPUT SHAFT SHEAVE P.D. (in.)	COOLING METHOD
3 HP Motor (cont.)			
	HSM107C-20	2.1	—
	HSM107C-14	2.8	—
	HSM107C-09	3.5	—
76	HSM107C-25	2.0	—
	HSM107C-20	2.1	—
	HSM107C-14	2.8	—
	HSM107C-09	3.4	—
77 - 79	HSM107C-25	2.0	—
	HSM107C-20	2.2	—
	HSM107C-14	2.8	—
	HSM107C-09	3.4	—
80	HSM107C-25	2.0	—
	HSM107C-20	2.2	—
	HSM107C-14	2.9	—
	HSM107C-09	3.4	—
81 - 83	HSM107C-25	2.0	—
	HSM107C-20	2.2	—
	HSM107C-14	2.9	—
	HSM107C-09	3.5	—
84 - 86	HSM107C-25	2.1	—
	HSM107C-20	2.2	—
	HSM107C-14	2.9	—
	HSM107C-09	3.5	—
87 - 90	HSM107C-20	2.3	—
	HSM107C-14	2.9	—
	HSM107C-09	3.5	—
91 - 93	HSM107C-20	2.3	—
	HSM107C-14	3.0	—
	HSM107C-09	3.5	—
94 - 97	HSM107C-20	2.3	—
	HSM107C-14	3.0	—
	HSM107C-09	3.6	—
98 - 99	HSM107C-20	2.3	—
	HSM107C-14	2.9	—
	HSM107C-09	3.7	—
100	HSM107C-14	2.9	—
	HSM107C-09	3.7	—
	HSM107C-05	5.6	—
101 - 102	HSM107C-09	3.7	—
	HSM107C-05	5.5	—
103 - 116	HSM107C-09	3.6	—
	HSM107C-05	5.5	—
117 - 220	HSM107C-09	3.6	—
	HSM107C-05	5.3	—
221 - 328	HSM107C-05	5.2	—
329 - 400	HSM107C-05	5.4	—
5 HP Motor			
10	HSM307H-25	2.0	—
	HSM307H-20	2.4	—
	HSM307H-14	3.7	—
11 - 12	HSM215G-25	2.3	—
	HSM215G-20	2.9	—
	HSM215G-14	4.4	—
13 - 14	HSM215G-25	2.4	—
	HSM215G-20	2.9	—
	HSM215G-14	4.5	—
15 - 17	HSM215G-25	2.4	—
	HSM215G-20	3.0	—
	HSM215G-14	4.5	—
18 - 21	HSM207F-25	1.7	—
	HSM207F-20	2.1	—
	HSM207F-14	3.2	—

OUTPUT RPM	GEARBOX SIZE†	MIN INPUT SHAFT SHEAVE P.D. (in.)	COOLING METHOD
5 HP Motor (cont.)			
22 - 25	HSM207F-25	1.8	—
	HSM207F-20	2.1	—
	HSM207F-14	3.2	—
26	HSM203E-25	2.4	—
	HSM203E-20	2.8	—
	HSM203E-14	4.1	—
27	HSM203E-25	2.5	—
	HSM203E-20	2.8	—
	HSM203E-14	4.1	—
28	HSM203E-25	2.5	—
	HSM203E-20	2.9	—
	HSM203E-14	4.1	—
29 - 30	HSM203E-25	2.6	—
	HSM203E-20	2.9	—
	HSM203E-14	4.1	—
	HSM203E-09	5.6	—
31 - 33	HSM203E-25	2.6	—
	HSM203E-20	3.0	—
	HSM203E-14	4.1	—
	HSM203E-09	5.7	—
34	HSM203E-25	2.7	—
	HSM203E-20	3.0	—
	HSM203E-14	4.1	—
	HSM203E-09	5.8	—
35	HSM203E-25	2.7	—
	HSM203E-20	3.0	—
	HSM203E-14	4.0	—
	HSM203E-09	5.9	—
36 - 37	HSM203E-25	2.7	—
	HSM203E-20	3.1	—
	HSM203E-14	4.0	—
	HSM203E-09	5.8	—
38 - 41	HSM203E-25	2.7	—
	HSM203E-20	3.1	—
	HSM203E-14	4.0	—
	HSM203E-09	5.6	—
42 - 43	HSM203E-25	2.8	—
	HSM203E-20	3.1	—
	HSM203E-14	4.1	—
	HSM203E-09	5.4	—
44 - 45	HSM115D-25	2.4	—
	HSM115D-20	2.7	—
	HSM115D-14	3.4	—
	HSM115D-09	5.0	—
46 - 47	HSM115D-25	2.4	—
	HSM115D-20	2.7	—
	HSM115D-14	3.5	—
	HSM115D-09	4.9	—
48 - 49	HSM115D-25	2.4	—
	HSM115D-20	2.7	—
	HSM115D-14	3.5	—
	HSM115D-09	4.8	—
50 - 54	HSM115D-25	2.5	—
	HSM115D-20	2.7	—
	HSM115D-14	3.5	—
	HSM115D-09	4.8	—
55 - 61	HSM115D-25	2.5	—
	HSM115D-20	2.7	—
	HSM115D-14	3.5	—
	HSM115D-09	4.6	—
62 - 65	HSM115D-25	2.5	—
	HSM115D-20	2.7	—

NOTE: †Consult factory for delivery of units with 9:1 and 20:1 ratios.

CLASS I HSM Speed Reducer Selection (SF = 1.0)

OUTPUT RPM	GEARBOX SIZE†	MIN INPUT SHAFT SHEAVE P.D. (in.)	COOLING METHOD
5 HP Motor (cont.)			
66 - 67	HSM115D-14	3.6	—
	HSM115D-09	4.6	—
	HSM115D-25	2.5	—
	HSM115D-20	2.8	—
68 - 71	HSM115D-14	3.6	—
	HSM115D-09	4.7	—
	HSM115D-25	2.6	—
	HSM115D-20	2.8	—
	HSM115D-14	3.6	—
72	HSM115D-09	4.7	—
	HSM115D-25	2.6	—
	HSM115D-20	2.8	—
	HSM115D-14	3.7	—
73 - 74	HSM115D-09	4.8	—
	HSM115D-25	2.6	—
	HSM115D-20	2.9	—
	HSM115D-14	3.7	—
75 - 76	HSM115D-09	4.8	—
	HSM115D-25	2.7	—
	HSM115D-20	2.9	—
	HSM115D-14	3.8	—
77 - 79	HSM115D-09	4.9	—
	HSM107C-25	2.0	—
	HSM107C-20	2.2	—
	HSM107C-14	2.8	—
80 - 81	HSM115D-09	4.9	—
	HSM107C-25	2.0	—
	HSM107C-20	2.2	—
	HSM107C-14	2.9	—
82 - 83	HSM115D-09	5.0	—
	HSM107C-25	2.0	—
	HSM107C-20	2.2	—
	HSM107C-14	2.9	—
84 - 86	HSM107C-09	3.5	—
	HSM107C-25	2.1	—
	HSM107C-20	2.2	—
	HSM107C-14	2.9	—
87 - 90	HSM107C-09	3.5	—
	HSM107C-20	2.3	—
	HSM107C-14	2.9	—
	HSM107C-09	3.5	—
91 - 93	HSM107C-20	2.3	—
	HSM107C-14	3.0	—
	HSM107C-09	3.5	—
	HSM107C-09	3.5	—
94 - 97	HSM107C-20	2.3	—
	HSM107C-14	3.0	—
	HSM107C-09	3.6	—
	HSM107C-20	2.3	—
98 - 99	HSM107C-14	2.9	—
	HSM107C-09	3.7	—
	HSM107C-14	2.9	—
	HSM107C-09	3.7	—
100	HSM107C-05	5.6	—
	HSM107C-09	3.7	—
101 - 102	HSM107C-09	3.7	—
	HSM107C-05	5.5	—
103 - 116	HSM107C-09	3.6	—
	HSM107C-05	5.5	—
117 - 220	HSM107C-09	3.6	—
	HSM107C-05	5.3	—
221 - 328	HSM107C-05	5.2	—
	HSM107C-05	5.4	—

OUTPUT RPM	GEARBOX SIZE†	MIN INPUT SHAFT SHEAVE P.D. (in.)	COOLING METHOD
7 1/2 HP Motor			
10	HSM315J-25	2.8	—
	HSM315J-20	3.4	—
	HSM315J-14	5.2	—
11	HSM315J-25	2.8	—
	HSM315J-20	3.5	—
	HSM315J-14	5.2	—
12 - 14	HSM307H-25	2.0	—
	HSM307H-20	2.5	—
	HSM307H-14	3.7	—
15	HSM307H-25	2.1	—
	HSM307H-20	2.5	—
	HSM307H-14	3.8	—
16 - 20	HSM215G-25	2.4	—
	HSM215G-20	3.0	—
	HSM215G-14	4.5	—
21 - 22	HSM215G-25	2.5	—
	HSM215G-20	3.0	—
	HSM215G-14	4.6	—
23	HSM215G-25	2.6	—
	HSM215G-20	3.0	—
	HSM215G-14	4.6	—
24	HSM215G-25	2.6	—
	HSM215G-20	3.0	—
	HSM215G-14	4.7	—
25 - 26	HSM215G-25	2.7	—
	HSM215G-20	3.1	—
	HSM215G-14	4.7	—
27	HSM207F-25	1.9	—
	HSM207F-20	2.2	—
	HSM207F-14	3.2	—
28 - 33	HSM207F-25	2.0	—
	HSM207F-20	2.2	—
	HSM207F-14	3.2	—
34 - 36	HSM207F-25	2.1	—
	HSM207F-20	2.4	—
	HSM207F-14	3.2	—
37	HSM207F-25	2.1	—
	HSM207F-20	2.4	—
	HSM207F-14	3.1	—
38 - 40	HSM207F-25	2.1	—
	HSM207F-20	2.4	—
	HSM207F-14	3.2	—
41 - 43	HSM203E-25	2.8	—
	HSM203E-20	3.1	—
	HSM203E-14	4.1	—
44	HSM203E-25	2.8	—
	HSM203E-20	3.2	—
	HSM203E-14	4.1	—
45 - 48	HSM203E-25	2.8	—
	HSM203E-20	3.2	—
	HSM203E-14	4.1	—
49 - 54	HSM203E-09	5.4	—
	HSM203E-25	2.8	—
	HSM203E-20	3.2	—
55 - 59	HSM203E-14	4.1	—
	HSM203E-09	5.3	—
	HSM203E-25	2.8	—
60 - 66	HSM203E-20	3.2	—
	HSM203E-14	4.2	—
	HSM203E-09	5.3	—

OUTPUT RPM	GEARBOX SIZE†	MIN INPUT SHAFT SHEAVE P.D. (in.)	COOLING METHOD
7 1/2 HP Motor (cont.)			
67 - 71	HSM203E-14	4.2	—
	HSM203E-09	5.4	—
	HSM203E-25	3.0	—
	HSM203E-20	3.3	—
72	HSM203E-14	4.3	—
	HSM203E-09	5.4	—
	HSM203E-25	3.1	—
	HSM203E-20	3.4	—
73	HSM203E-14	4.3	—
	HSM203E-09	5.5	—
	HSM203E-25	3.1	—
	HSM203E-20	3.4	—
74	HSM203E-14	4.4	—
	HSM203E-09	5.5	—
	HSM115D-25	2.6	—
	HSM115D-20	2.9	—
75 - 76	HSM115D-14	3.7	—
	HSM115D-09	4.8	—
	HSM115D-25	2.7	—
	HSM115D-20	2.9	—
77 - 79	HSM115D-14	3.8	—
	HSM115D-09	4.9	—
	HSM115D-25	2.7	—
	HSM115D-20	3.0	—
80 - 83	HSM115D-14	3.8	—
	HSM115D-09	4.9	—
	HSM115D-25	2.8	—
	HSM115D-20	3.0	—
84	HSM115D-14	3.9	—
	HSM115D-09	5.0	—
	HSM115D-25	2.8	—
	HSM115D-20	3.1	—
85 - 86	HSM115D-14	3.9	—
	HSM115D-09	5.1	—
	HSM115D-25	2.8	—
	HSM115D-20	3.1	—
87 - 92	HSM115D-14	3.9	—
	HSM115D-09	5.2	—
	HSM115D-20	3.1	—
	HSM115D-14	4.0	—
93 - 96	HSM115D-09	5.2	—
	HSM115D-20	3.2	—
	HSM115D-14	4.0	—
	HSM115D-09	5.3	—
97 - 99	HSM115D-20	3.1	—
	HSM115D-14	4.0	—
	HSM115D-09	5.2	—
	HSM115D-14	3.9	—
100	HSM115D-14	3.9	—
	HSM115D-09	5.1	—
	HSM115D-05	7.6	—
	HSM115D-09	5.1	—
101 - 111	HSM115D-05	7.5	—
	HSM115D-09	5.1	—
112 - 124	HSM115D-05	7.3	—
	HSM115D-09	4.9	—
125 - 142	HSM115D-09	4.9	—
	HSM115D-05	7.2	—
143 - 144	HSM115D-09	4.9	—
	HSM115D-05	7.1	—
145 - 220	HSM107C-09	3.6	—
	HSM107C-05	5.2	—
221 - 328	HSM107C-05	5.2	—
	HSM107C-05	5.4	—

NOTE: †Consult factory for delivery of units with 9:1 and 20:1 ratios.

HSM Speed Reducer Selection (SF = 1.0) CLASS I

OUTPUT RPM	GEARBOX SIZE†	MIN INPUT SHAFT SHEAVE P.D. (in.)	COOLING METHOD
10 HP Motor			
10	HSM315J-25	2.8	—
	HSM315J-20	3.4	—
	HSM315J-14	5.2	—
11 - 12	HSM315J-25	2.8	—
	HSM315J-20	3.5	—
	HSM315J-14	5.2	—
13	HSM315J-25	2.9	—
	HSM315J-20	3.5	—
	HSM315J-14	5.3	—
14	HSM315J-25	2.9	—
	HSM315J-20	3.6	—
	HSM315J-14	5.4	—
15 - 16	HSM307H-25	2.1	—
	HSM307H-20	2.5	—
	HSM307H-14	3.8	—
17 - 20	HSM307H-25	2.1	—
	HSM307H-20	2.6	—
	HSM307H-14	3.9	—
21 - 22	HSM215G-25	2.5	—
	HSM215G-20	3.0	—
	HSM215G-14	4.6	—
23	HSM215G-25	2.6	—
	HSM215G-20	3.0	—
	HSM215G-14	4.6	—
24	HSM215G-25	2.6	—
	HSM215G-20	3.0	—
	HSM215G-14	4.7	—
25 - 26	HSM215G-25	2.7	—
	HSM215G-20	3.1	—
	HSM215G-14	4.7	—
27 - 29	HSM215G-25	2.7	—
	HSM215G-20	3.2	—
	HSM215G-14	4.7	—
30 - 32	HSM215G-25	2.9	—
	HSM215G-20	3.3	—
	HSM215G-14	4.7	—
33	HSM215G-25	2.9	—
	HSM215G-20	3.3	—
	HSM215G-14	4.6	—
34	HSM215G-25	2.9	—
	HSM215G-20	3.4	—
	HSM215G-14	4.6	—
35	HSM215G-25	3.0	—
	HSM215G-20	3.4	—
	HSM215G-14	4.6	—
36	HSM207F-25	2.1	—
	HSM207F-20	2.4	—
	HSM207F-14	3.2	—
37	HSM207F-25	2.1	—
	HSM207F-20	2.4	—
	HSM207F-14	3.1	—
38 - 44	HSM207F-25	2.1	—
	HSM207F-20	2.4	—
	HSM207F-14	3.2	—
45 - 50	HSM207F-25	2.1	—
	HSM207F-20	2.5	—
	HSM207F-14	3.2	—
51 - 60	HSM207F-25	2.2	—
	HSM207F-20	2.5	—
	HSM207F-14	3.2	—
61	HSM203E-25	2.9	—
	HSM203E-20	3.2	—

OUTPUT RPM	GEARBOX SIZE†	MIN INPUT SHAFT SHEAVE P.D. (in.)	COOLING METHOD
10 HP Motor (cont.)			
	HSM203E-14	4.2	—
62 - 66	HSM203E-25	2.9	—
	HSM203E-20	3.2	—
	HSM203E-14	4.2	—
	HSM203E-09	5.4	—
67 - 71	HSM203E-25	3.0	—
	HSM203E-20	3.3	—
	HSM203E-14	4.3	—
	HSM203E-09	5.4	—
72	HSM203E-25	3.1	—
	HSM203E-20	3.4	—
	HSM203E-14	4.3	—
	HSM203E-09	5.5	—
73	HSM203E-25	3.1	—
	HSM203E-20	3.4	—
	HSM203E-14	4.4	—
	HSM203E-09	5.5	—
74	HSM203E-25	3.2	—
	HSM203E-20	3.4	—
	HSM203E-14	4.4	—
	HSM203E-09	5.6	—
75 - 76	HSM203E-25	3.2	—
	HSM203E-20	3.5	—
	HSM203E-14	4.4	—
	HSM203E-09	5.6	—
77	HSM203E-25	3.3	—
	HSM203E-20	3.5	—
	HSM203E-14	4.5	—
	HSM203E-09	5.7	—
78	HSM203E-25	3.3	—
	HSM203E-20	3.6	—
	HSM203E-14	4.5	—
	HSM203E-09	5.7	—
79 - 80	HSM203E-25	3.4	—
	HSM203E-20	3.6	—
	HSM203E-14	4.5	—
	HSM203E-09	5.7	—
81	HSM203E-20	3.6	—
	HSM203E-14	4.6	—
	HSM203E-09	5.8	—
82 - 83	HSM203E-20	3.7	—
	HSM203E-14	4.6	—
	HSM203E-09	5.8	—
84 - 85	HSM203E-20	3.7	—
	HSM203E-14	4.6	—
	HSM203E-09	5.9	—
86 - 89	HSM203E-20	3.8	—
	HSM203E-14	4.7	—
	HSM203E-09	5.9	—
90 - 93	HSM203E-20	3.9	—
	HSM203E-14	4.7	—
	HSM203E-09	6.0	—
94 - 99	HSM203E-20	4.0	—
	HSM203E-14	4.8	—
	HSM203E-09	6.0	—
100	HSM203E-14	4.7	—
	HSM203E-09	6.0	—
	HSM203E-05	8.7	—
101 - 106	HSM203E-09	6.0	—
	HSM203E-05	8.7	—
107 - 111	HSM115D-09	5.1	—
	HSM115D-05	7.4	—

OUTPUT RPM	GEARBOX SIZE†	MIN INPUT SHAFT SHEAVE P.D. (in.)	COOLING METHOD
10 HP Motor (cont.)			
112 - 124	HSM115D-09	5.1	—
	HSM115D-05	7.3	—
125 - 142	HSM115D-09	4.9	—
	HSM115D-05	7.2	—
143 - 147	HSM115D-09	4.9	—
	HSM115D-05	7.1	—
148 - 152	HSM115D-09	4.9	—
	HSM115D-05	7.2	—
153 - 220	HSM115D-09	4.9	—
	HSM115D-05	7.1	—
221 - 231	HSM115D-05	7.1	—
232 - 328	HSM107C-05	5.2	—
329 - 400	HSM107C-05	5.4	—
15 HP Motor			
10	HSM415K-25	3.7	—
	HSM415K-20	4.4	—
	HSM415K-14	6.6	—
11	HSM407S-25	2.9	—
	HSM407S-20	3.5	—
	HSM407S-14	5.3	—
12 - 14	HSM407S-25	2.9	—
	HSM407S-20	3.6	—
	HSM407S-14	5.4	—
15 - 18	HSM315J-25	2.9	—
	HSM315J-20	3.6	—
	HSM315J-14	5.4	—
19	HSM315J-25	3.0	—
	HSM315J-20	3.6	—
	HSM315J-14	5.5	—
20 - 21	HSM315J-25	3.0	—
	HSM315J-20	3.7	—
	HSM315J-14	5.5	—
22 - 25	HSM307H-25	2.2	—
	HSM307H-20	2.6	—
	HSM307H-14	3.9	—
26	HSM307H-25	2.3	—
	HSM307H-20	2.7	—
	HSM307H-14	4.0	—
27 - 29	HSM307H-25	2.4	—
	HSM307H-20	2.7	—
	HSM307H-14	4.0	—
30	HSM307H-25	2.5	—
	HSM307H-20	2.8	—
	HSM307H-14	4.0	—
31 - 32	HSM215G-25	2.9	—
	HSM215G-20	3.3	—
	HSM215G-14	4.7	—
33	HSM215G-25	2.9	—
	HSM215G-20	3.3	—
	HSM215G-14	4.6	—
34	HSM215G-25	2.9	—
	HSM215G-20	3.4	—
	HSM215G-14	4.6	—
35 - 37	HSM215G-25	3.0	—
	HSM215G-20	3.4	—
	HSM215G-14	4.6	—
38 - 39	HSM215G-25	3.0	—
	HSM215G-20	3.5	—
	HSM215G-14	4.6	—
40 - 53	HSM215G-25	3.1	—
	HSM215G-20	3.5	—
	HSM215G-14	4.6	—

NOTE: †Consult factory for delivery of units with 9:1 and 20:1 ratios.

CLASS I HSM Speed Reducer Selection (SF = 1.0)

OUTPUT RPM	GEARBOX SIZE†	MIN INPUT SHAFT SHEAVE P.D. (in.)	COOLING METHOD
15 HP Motor (cont.)			
54 - 57	HSM215G-25	3.1	—
	HSM215G-20	3.5	—
	HSM215G-14	4.7	—
58 - 60	HSM215G-25	3.1	—
	HSM215G-20	3.6	—
	HSM215G-14	4.7	—
61 - 62	HSM215G-25	3.2	—
	HSM215G-20	3.6	—
	HSM215G-14	4.7	—
63 - 69	HSM207F-25	2.2	—
	HSM207F-20	2.5	—
	HSM207F-14	3.3	—
70 - 71	HSM207F-25	2.2	—
	HSM207F-20	2.6	—
	HSM207F-14	3.3	—
72 - 74	HSM207F-25	2.3	—
	HSM207F-20	2.6	—
	HSM207F-14	3.4	—
75	HSM207F-25	2.3	—
	HSM207F-20	2.7	—
	HSM207F-14	3.4	—
76	HSM207F-25	2.3	—
	HSM207F-20	2.7	—
	HSM207F-14	3.5	—
77 - 80	HSM207F-25	2.4	—
	HSM207F-20	2.7	—
	HSM207F-14	3.5	—
81 - 89	HSM207F-20	2.8	—
	HSM207F-14	3.6	—
90 - 91	HSM207F-20	2.8	—
	HSM207F-14	3.7	—
92 - 93	HSM207F-20	2.9	—
	HSM207F-14	3.7	—
94 - 97	HSM203E-20	4.0	—
	HSM203E-14	4.8	—
98 - 99	HSM203E-20	4.0	—
	HSM203E-14	4.7	—
	HSM203E-09	6.0	—
100	HSM203E-14	4.7	—
	HSM203E-09	6.0	—
	HSM203E-05	8.7	—
101 - 109	HSM203E-09	6.0	—
	HSM203E-05	8.7	—
110 - 121	HSM203E-09	5.9	—
	HSM203E-05	8.5	—
122 - 165	HSM203E-09	5.8	—
	HSM203E-05	8.4	—
166 - 192	HSM203E-09	5.8	—
	HSM203E-05	8.2	—
193 - 204	HSM203E-09	5.7	—
	HSM203E-05	8.3	—
205 - 216	HSM203E-09	5.7	—
	HSM203E-05	8.2	—
217	HSM203E-09	5.8	—
	HSM115D-05	7.1	—
218 - 220	HSM115D-09	4.9	—
	HSM115D-05	7.1	—
221 - 275	HSM115D-05	7.1	—
276 - 343	HSM115D-05	7.2	—
344 - 398	HSM115D-05	7.4	—
399 - 400	HSM115D-05	7.6	—

OUTPUT RPM	GEARBOX SIZE†	MIN INPUT SHAFT SHEAVE P.D. (in.)	COOLING METHOD
20 HP Motor			
10 - 11	HSM507L-25	5.0	—
	HSM507L-20	6.3	—
	HSM507L-14	9.3	—
12	HSM415K-25	3.8	—
	HSM415K-20	4.5	—
	HSM415K-14	6.8	—
13	HSM415K-25	3.8	—
	HSM415K-20	4.5	—
	HSM415K-14	6.9	—
14	HSM415K-25	3.9	—
	HSM415K-20	4.6	—
	HSM415K-14	6.9	—
15	HSM407S-25	3.0	—
	HSM407S-20	3.6	—
	HSM407S-14	5.5	—
16 - 18	HSM407S-25	3.0	—
	HSM407S-20	3.7	—
	HSM407S-14	5.5	—
19	HSM315J-25	3.0	—
	HSM315J-20	3.6	—
	HSM315J-14	5.5	—
20 - 21	HSM315J-25	3.0	—
	HSM315J-20	3.7	—
	HSM315J-14	5.5	—
22 - 23	HSM315J-25	3.1	—
	HSM315J-20	3.7	—
	HSM315J-14	5.5	—
24 - 27	HSM315J-25	3.2	—
	HSM315J-20	3.7	—
	HSM315J-14	5.6	—
28	HSM315J-25	3.4	—
	HSM315J-20	3.9	—
	HSM315J-14	5.6	—
29	HSM307H-25	2.4	—
	HSM307H-20	2.8	—
	HSM307H-14	4.0	—
30 - 31	HSM307H-25	2.5	—
	HSM307H-20	2.8	—
	HSM307H-14	4.0	—
32	HSM307H-25	2.5	—
	HSM307H-20	2.8	—
	HSM307H-14	3.9	—
33 - 36	HSM307H-25	2.5	—
	HSM307H-20	2.9	—
	HSM307H-14	3.9	—
37	HSM307H-25	2.6	—
	HSM307H-20	2.9	—
	HSM307H-14	3.9	—
38 - 43	HSM307H-25	2.6	—
	HSM307H-20	3.0	—
	HSM307H-14	3.9	—
44 - 53	HSM215G-25	3.1	—
	HSM215G-20	3.5	—
	HSM215G-14	4.6	—
54 - 57	HSM215G-25	3.1	—
	HSM215G-20	3.5	—
	HSM215G-14	4.7	—
58 - 60	HSM215G-25	3.1	—
	HSM215G-20	3.6	—
	HSM215G-14	4.7	—
61 - 70	HSM215G-25	3.2	—
	HSM215G-20	3.6	—

OUTPUT RPM	GEARBOX SIZE†	MIN INPUT SHAFT SHEAVE P.D. (in.)	COOLING METHOD
20 HP Motor (cont.)			
71	HSM215G-14	4.7	—
	HSM215G-25	3.2	—
	HSM215G-20	3.7	—
	HSM215G-14	4.8	—
72 - 75	HSM215G-25	3.2	—
	HSM215G-20	3.7	—
	HSM215G-14	4.9	—
76	HSM215G-25	3.4	—
	HSM215G-20	3.8	—
	HSM215G-14	5.0	—
77 - 79	HSM215G-25	3.4	—
	HSM215G-20	3.9	—
	HSM215G-14	5.0	—
80	HSM215G-25	3.5	—
	HSM215G-20	3.9	—
	HSM215G-14	5.1	—
81	HSM215G-20	3.9	—
	HSM215G-14	5.1	—
82	HSM215G-20	4.0	—
	HSM215G-14	5.1	—
83 - 84	HSM215G-20	4.0	—
	HSM215G-14	5.2	—
85 - 89	HSM207F-20	2.8	—
	HSM207F-14	3.6	—
90 - 91	HSM207F-20	2.8	—
	HSM207F-14	3.7	—
92 - 97	HSM207F-20	2.9	—
	HSM207F-14	3.7	—
98 - 99	HSM207F-20	2.8	—
	HSM207F-14	3.6	—
100	HSM207F-14	3.6	—
	HSM207F-05	6.8	—
101 - 113	HSM207F-05	6.8	—
114 - 156	HSM207F-05	6.6	—
157 - 166	HSM207F-05	6.4	—
167	HSM203E-05	8.2	—
168 - 192	HSM203E-09	5.8	—
	HSM203E-05	8.2	—
193 - 204	HSM203E-09	5.7	—
	HSM203E-05	8.3	—
205 - 220	HSM203E-09	5.7	—
	HSM203E-05	8.2	—
221 - 244	HSM203E-05	8.2	—
245 - 292	HSM203E-05	8.3	—
293 - 327	HSM203E-05	8.5	—
328 - 343	HSM115D-05	7.3	—
344 - 398	HSM115D-05	7.4	—
399 - 400	HSM115D-05	7.6	—
25 HP Motor			
10 - 13	HSM507L-25	5.0	—
	HSM507L-20	6.3	—
	HSM507L-14	9.3	—
14 - 17	HSM415K-25	3.9	—
	HSM415K-20	4.6	—
	HSM415K-14	6.9	—
18 - 20	HSM407S-25	3.0	—
	HSM407S-20	3.7	—
	HSM407S-14	5.6	—
21 - 22	HSM407S-25	3.1	—
	HSM407S-20	3.7	—
	HSM407S-14	5.6	—
23	HSM407S-25	3.2	—

NOTE: †Consult factory for delivery of units with 9:1 and 20:1 ratios.

HSM Speed Reducer Selection (SF = 1.0) CLASS I

OUTPUT RPM	GEARBOX SIZE†	MIN INPUT SHAFT SHEAVE P.D. (in.)	COOLING METHOD
25 HP Motor (cont.)			
24 - 27	HSM407S-20	3.8	—
	HSM407S-14	5.7	—
	HSM315J-25	3.2	—
28	HSM315J-20	3.7	—
	HSM315J-14	5.6	—
	HSM315J-25	3.4	—
29	HSM315J-20	3.9	—
	HSM315J-14	5.6	—
	HSM315J-25	3.5	—
30 - 31	HSM315J-20	3.9	—
	HSM315J-14	5.6	—
	HSM315J-25	3.5	—
32 - 35	HSM315J-20	4.0	—
	HSM315J-14	5.6	—
	HSM315J-25	3.6	—
36	HSM315J-20	4.0	—
	HSM315J-14	5.6	—
	HSM315J-25	3.6	—
37	HSM315J-20	4.2	—
	HSM315J-14	5.5	—
	HSM307H-25	2.6	—
38 - 54	HSM307H-20	2.9	—
	HSM307H-14	3.9	—
	HSM307H-25	2.6	—
55 - 57	HSM307H-20	3.0	—
	HSM307H-14	3.9	—
	HSM307H-25	2.6	—
58 - 59	HSM307H-20	3.0	—
	HSM307H-14	4.0	—
	HSM307H-25	2.7	—
60	HSM307H-20	3.0	—
	HSM307H-14	4.0	—
	HSM215G-25	3.1	—
61 - 70	HSM215G-20	3.6	—
	HSM215G-14	4.7	—
	HSM215G-25	3.2	—
71	HSM215G-20	3.6	—
	HSM215G-14	4.7	—
	HSM215G-25	3.2	—
72 - 75	HSM215G-20	3.7	—
	HSM215G-14	4.8	—
	HSM215G-25	3.2	—
76	HSM215G-20	3.7	—
	HSM215G-14	4.9	—
	HSM215G-25	3.4	—
77 - 79	HSM215G-20	3.8	—
	HSM215G-14	5.0	—
	HSM215G-25	3.4	—
80	HSM215G-20	3.9	—
	HSM215G-14	5.0	—
	HSM215G-25	3.5	—
81	HSM215G-20	3.9	—
	HSM215G-14	5.1	—
	HSM215G-25	3.9	—
82	HSM215G-20	4.0	—
	HSM215G-14	5.1	—
	HSM215G-25	4.0	—
83 - 85	HSM215G-20	4.0	—
	HSM215G-14	5.2	—
	HSM215G-25	4.0	—
86 - 94	HSM215G-20	5.2	—
	HSM215G-14	5.4	—
	HSM215G-25	5.3	—

OUTPUT RPM	GEARBOX SIZE†	MIN INPUT SHAFT SHEAVE P.D. (in.)	COOLING METHOD
25 HP Motor (cont.)			
100	HSM215G-14	5.2	—
	HSM215G-05	9.8	—
	HSM215G-05	9.7	—
101 - 110	HSM215G-05	9.5	—
	HSM207F-05	6.5	—
	HSM203E-05	8.2	—
111 - 125	HSM203E-05	8.3	—
	HSM203E-05	8.5	—
	HSM203E-05	8.7	—
126 - 237	HSM203E-05	8.8	—
	30 HP Motor		
	10 - 15	HSM507L-25	5.0
16 - 18	HSM507L-20	6.3	—
	HSM507L-14	9.3	—
	HSM415K-25	3.9	—
19 - 20	HSM415K-20	4.6	—
	HSM415K-14	7.0	—
	HSM415K-25	4.0	—
21 - 22	HSM415K-20	4.7	—
	HSM415K-14	7.1	—
	HSM407S-25	3.1	—
23 - 26	HSM407S-20	3.7	—
	HSM407S-14	5.6	—
	HSM407S-25	3.2	—
27	HSM407S-20	3.8	—
	HSM407S-14	5.7	—
	HSM407S-25	3.4	—
28	HSM407S-20	3.9	—
	HSM407S-14	5.7	—
	HSM315J-25	3.4	—
29	HSM315J-20	3.9	—
	HSM315J-14	5.6	—
	HSM315J-25	3.5	—
30 - 31	HSM315J-20	3.9	—
	HSM315J-14	5.6	—
	HSM315J-25	3.5	—
32 - 35	HSM315J-20	4.0	—
	HSM315J-14	5.6	—
	HSM315J-25	3.6	—
36	HSM315J-20	4.0	—
	HSM315J-14	5.6	—
	HSM315J-25	3.6	—
37 - 46	HSM315J-20	4.2	—
	HSM315J-14	5.5	—
	HSM315J-25	3.7	—
47 - 54	HSM315J-20	4.2	—
	HSM315J-14	5.4	—
	HSM307H-25	2.6	—
55 - 57	HSM307H-20	3.0	—
	HSM307H-14	3.9	—
	HSM307H-25	2.6	—
58 - 63	HSM307H-20	3.0	—
	HSM307H-14	4.0	—
	HSM307H-25	2.7	—
64 - 71	HSM307H-20	3.0	—
	HSM307H-14	4.0	—
	HSM307H-25	2.7	—
72 - 73	HSM307H-20	3.1	—
	HSM307H-14	4.0	—
	HSM307H-25	2.8	—
	HSM307H-20	3.2	—
	HSM307H-14	4.1	—

OUTPUT RPM	GEARBOX SIZE†	MIN INPUT SHAFT SHEAVE P.D. (in.)	COOLING METHOD
30 HP Motor (cont.)			
74 - 75	HSM215G-25	3.3	—
	HSM215G-20	3.8	—
	HSM215G-14	4.9	—
76	HSM215G-25	3.4	—
	HSM215G-20	3.8	—
	HSM215G-14	5.0	—
77 - 79	HSM215G-25	3.4	—
	HSM215G-20	3.9	—
	HSM215G-14	5.0	—
80	HSM215G-25	3.5	—
	HSM215G-20	3.9	—
	HSM215G-14	5.1	—
81	HSM215G-20	3.9	—
	HSM215G-14	5.1	—
	HSM215G-20	4.0	—
82	HSM215G-20	4.0	—
	HSM215G-14	5.1	—
	HSM215G-20	4.0	—
83 - 85	HSM215G-20	4.0	—
	HSM215G-14	5.2	—
	HSM215G-20	5.2	—
86 - 94	HSM215G-14	5.2	—
	HSM215G-14	5.4	—
	HSM215G-14	5.3	—
95	HSM215G-14	5.3	—
	HSM215G-14	5.2	—
	HSM215G-05	9.8	—
100	HSM215G-05	9.7	—
	HSM215G-05	9.5	—
	HSM215G-05	9.3	—
101 - 110	HSM215G-05	9.2	—
	HSM215G-05	9.2	—
	HSM207F-05	6.4	—
111 - 126	HSM203E-05	8.5	—
	HSM203E-05	8.7	—
	HSM203E-05	8.8	—
40 HP Motor			
10 - 11	HSM608M-25	10.0	—
	HSM608M-20	11.5	—
	HSM608M-14	17.5	—
12 - 15	HSM507L-25	5.0	—
	HSM507L-20	6.3	—
	HSM507L-14	9.3	—
16 - 20	HSM507L-25	5.0	—
	HSM507L-20	6.3	—
	HSM507L-14	9.0	—
21 - 23	HSM415K-25	4.0	—
	HSM415K-20	4.7	—
	HSM415K-14	7.1	—
24 - 26	HSM415K-25	4.2	—
	HSM415K-20	4.7	—
	HSM415K-14	7.2	—
27	HSM415K-25	4.4	—
	HSM415K-20	4.9	—
	HSM415K-14	7.2	—
28	HSM407S-25	3.5	—
	HSM407S-20	3.9	—
	HSM407S-14	5.7	—
29	HSM407S-25	3.5	—
	HSM407S-20	4.0	—
	HSM407S-14	5.7	—
30 - 32	HSM407S-20	4.0	—
	HSM407S-14	5.7	—
	HSM407S-25	3.6	—
33	HSM407S-20	4.0	—
	HSM407S-14	5.7	—
	HSM407S-25	3.6	—
	HSM407S-20	4.1	—
	HSM407S-14	5.6	—

NOTE: †Consult factory for delivery of units with 9:1 and 20:1 ratios.

CLASS I HSM Speed Reducer Selection (SF = 1.0)

OUTPUT RPM	GEARBOX SIZE†	MIN INPUT SHAFT SHEAVE P.D. (in.)	COOLING METHOD
40 HP Motor (cont.)			
34	HSM407S-25	3.6	—
	HSM407S-20	4.2	—
	HSM407S-14	5.6	—
35 - 38	HSM407S-25	3.7	—
	HSM407S-20	4.2	—
	HSM407S-14	5.6	—
39 - 57	HSM315J-25	3.7	—
	HSM315J-20	4.2	—
	HSM315J-14	5.5	—
58	HSM315J-25	3.9	—
	HSM315J-20	4.3	—
	HSM315J-14	5.7	—
59 - 68	HSM315J-25	3.9	—
	HSM315J-20	4.4	—
	HSM315J-14	5.7	—
69 - 71	HSM307H-25	2.7	—
	HSM307H-20	3.1	—
	HSM307H-14	4.0	—
72 - 73	HSM307H-25	2.8	—
	HSM307H-20	3.2	—
	HSM307H-14	4.1	—
74 - 76	HSM307H-25	2.8	—
	HSM307H-20	3.2	—
	HSM307H-14	4.2	—
77 - 80	HSM307H-25	2.9	—
	HSM307H-20	3.3	—
	HSM307H-14	4.2	—
81 - 82	HSM307H-14	4.3	—
83 - 99	HSM307H-14	4.4	—
100	HSM307H-14	4.4	—
	HSM307H-05	8.4	—
101 - 106	HSM307H-05	8.4	—
107	HSM307H-05	8.2	—
108 - 116	HSM215G-05	9.6	—
117 - 152	HSM215G-05	9.4	—
153 - 269	HSM215G-05	9.2	—
270 - 308	HSM207F-05	6.4	—
309 - 358	HSM207F-05	6.6	—
359 - 400	HSM207F-05	6.7	—
50 HP Motor			
10 - 11	HSM608M-25	10.0	—
	HSM608M-20	11.5	—
	HSM608M-14	17.5	—
12 - 13	HSM608M-25	10.0	—
	HSM608M-20	11.5	—
	HSM608M-14	17.3	—
14	HSM608M-25	9.8	—
	HSM608M-20	11.5	—
	HSM608M-14	17.3	—
15	HSM507L-25	5.0	—
	HSM507L-20	6.3	—
	HSM507L-14	9.3	—
16 - 21	HSM507L-25	5.0	—
	HSM507L-20	6.3	—
	HSM507L-14	9.0	—
22 - 24	HSM507L-25	5.0	—
	HSM507L-20	6.0	—
	HSM507L-14	9.0	—
25	HSM507L-25	5.3	—
	HSM507L-20	6.0	—
	HSM507L-14	9.0	—
26	HSM415K-25	4.3	—

OUTPUT RPM	GEARBOX SIZE†	MIN INPUT SHAFT SHEAVE P.D. (in.)	COOLING METHOD
50 HP Motor (cont.)			
	HSM415K-20	4.8	—
	HSM415K-14	7.2	—
27 - 29	HSM415K-25	4.4	—
	HSM415K-20	4.9	—
	HSM415K-14	7.2	—
30 - 32	HSM415K-25	4.6	—
	HSM415K-20	5.0	—
	HSM415K-14	7.2	—
33	HSM415K-25	4.7	—
	HSM415K-20	5.1	—
	HSM415K-14	7.1	—
34	HSM415K-25	4.7	—
	HSM415K-20	5.2	—
	HSM415K-14	7.1	—
35 - 47	HSM407S-25	3.7	—
	HSM407S-20	4.2	—
	HSM407S-14	5.6	—
48 - 50	HSM407S-25	3.8	—
	HSM407S-20	4.4	—
	HSM407S-14	5.6	—
51 - 52	HSM407S-25	3.8	—
	HSM407S-20	4.4	—
	HSM407S-14	5.7	—
53 - 57	HSM315J-25	3.8	—
	HSM315J-20	4.3	—
	HSM315J-14	5.6	—
58	HSM315J-25	3.9	—
	HSM315J-20	4.3	—
	HSM315J-14	5.7	—
59 - 70	HSM315J-25	3.9	—
	HSM315J-20	4.4	—
	HSM315J-14	5.7	—
71	HSM315J-25	4.0	—
	HSM315J-20	4.5	—
	HSM315J-14	5.8	—
72 - 74	HSM315J-25	4.0	—
	HSM315J-20	4.6	—
	HSM315J-14	5.9	—
75 - 76	HSM407S-25	4.1	—
	HSM407S-20	4.7	—
	HSM407S-14	6.0	—
77 - 78	HSM407S-25	4.2	—
	HSM407S-20	4.7	—
	HSM315J-14	6.1	—
79 - 84	HSM315J-14	6.2	—
85 - 99	HSM307H-14	4.4	—
100	HSM307H-14	4.4	—
	HSM307H-05	8.4	—
101 - 106	HSM307H-05	8.4	—
107 - 120	HSM307H-05	8.2	—
121 - 162	HSM307H-05	8.0	—
163	HSM307H-05	7.8	—
164 - 278	HSM215G-05	9.2	—
279 - 340	HSM215G-05	9.3	—
341 - 365	HSM215G-05	9.5	—
366 - 400	HSM207F-05	6.7	—
60 HP Motor			
10 - 11	HSM608M-25	10.0	—
	HSM608M-20	11.5	—
	HSM608M-14	17.5	—
12 - 13	HSM608M-25	10.0	—
	HSM608M-20	11.5	—
	HSM608M-14	17.5	—
12 - 13	HSM608M-25	10.0	—
	HSM608M-20	11.5	—

OUTPUT RPM	GEARBOX SIZE†	MIN INPUT SHAFT SHEAVE P.D. (in.)	COOLING METHOD
60 HP Motor (cont.)			
	HSM608M-14	17.3	—
14 - 15	HSM608M-25	9.8	—
	HSM608M-20	11.5	—
	HSM608M-14	17.3	—
16 - 17	HSM608M-25	9.8	—
	HSM608M-20	11.5	—
	HSM608M-14	17.0	—
18 - 21	HSM507L-25	5.0	—
	HSM507L-20	6.3	—
	HSM507L-14	9.0	—
22 - 24	HSM507L-25	5.0	—
	HSM507L-20	6.0	—
	HSM507L-14	9.0	—
25 - 26	HSM507L-25	5.3	—
	HSM507L-20	6.0	—
	HSM507L-14	9.0	—
27 - 30	HSM507L-25	5.3	—
	HSM507L-20	6.3	—
	HSM507L-14	8.8	—
31 - 32	HSM415K-25	4.6	—
	HSM415K-20	5.1	—
	HSM415K-14	7.2	—
33	HSM415K-25	4.7	—
	HSM415K-20	5.1	—
	HSM415K-14	7.1	—
34 - 38	HSM415K-25	4.7	—
	HSM415K-20	5.2	—
	HSM415K-14	7.1	—
39 - 41	HSM415K-25	4.8	—
	HSM415K-20	5.4	—
	HSM415K-14	7.0	—
42 - 43	HSM415K-25	4.9	—
	HSM415K-20	5.4	—
	HSM415K-14	7.0	—
44 - 47	HSM407S-25	3.8	—
	HSM407S-20	4.3	—
	HSM407S-14	5.6	—
48 - 50	HSM407S-25	3.8	—
	HSM407S-20	4.4	—
	HSM407S-14	5.6	—
51 - 57	HSM407S-25	3.8	—
	HSM407S-20	4.4	—
	HSM407S-14	5.7	—
58 - 66	HSM407S-25	3.9	—
	HSM407S-20	4.4	—
	HSM407S-14	5.7	—
67 - 70	HSM315J-25	3.9	—
	HSM315J-20	4.4	—
	HSM315J-14	5.7	—
71	HSM315J-25	4.0	—
	HSM315J-20	4.5	—
	HSM315J-14	5.8	—
72 - 74	HSM315J-25	4.0	—
	HSM315J-20	4.6	—
	HSM315J-14	5.9	—
75 - 76	HSM407S-25	4.1	—
	HSM407S-20	4.7	—
	HSM407S-14	6.0	—
77 - 78	HSM407S-25	4.2	—
	HSM407S-20	4.7	—
	HSM315J-14	6.1	—
79 - 87	HSM315J-14	6.2	—

NOTE: †Consult factory for delivery of units with 9:1 and 20:1 ratios.

HSM Speed Reducer Selection (SF = 1.0) CLASS I

OUTPUT RPM	GEARBOX SIZE†	MIN INPUT SHAFT SHEAVE P.D. (in.)	COOLING METHOD
60 HP Motor (cont.)			
88 - 99	HSM315J-14	6.4	—
100	HSM315J-14	6.4	—
	HSM315J-05	11.8	—
101 - 102	HSM315J-05	11.8	—
103 - 111	HSM315J-05	11.7	—
112 - 117	HSM315J-05	11.5	—
118 - 137	HSM307H-05	8.1	—
138 - 162	HSM307H-05	7.9	—
163 - 218	HSM307H-05	7.8	—
219 - 278	HSM215G-05	9.1	—
279 - 340	HSM215G-05	9.3	—
341 - 387	HSM215G-05	9.5	—
388 - 400	HSM215G-05	9.7	—
75 HP Motor			
13	HSM608M-25	10.0	—
	HSM608M-20	11.5	—
	HSM608M-14	17.3	—
14 - 15	HSM608M-25	9.8	—
	HSM608M-20	11.5	—
	HSM608M-14	17.3	—
16 - 17	HSM608M-25	9.8	—
	HSM608M-20	11.5	—
	HSM608M-14	17.0	—
18 - 19	HSM608M-25	9.8	—
	HSM608M-20	11.3	—
	HSM608M-14	17.0	—
20 - 22	HSM608M-25	9.8	—
	HSM608M-20	11.3	—
	HSM608M-14	16.8	—
23 - 24	HSM507L-25	5.0	—
	HSM507L-20	6.0	—
	HSM507L-14	9.0	—
25 - 26	HSM507L-25	5.3	—
	HSM507L-20	6.0	—
	HSM507L-14	9.0	—
27 - 30	HSM507L-25	5.3	—
	HSM507L-20	6.3	—
	HSM507L-14	8.8	—
31 - 32	HSM507L-25	5.5	—
	HSM507L-20	6.3	—
	HSM507L-14	8.8	—
33 - 34	HSM507L-25	5.5	—
	HSM507L-20	6.5	—
	HSM507L-14	8.8	—
35 - 38	HSM507L-25	5.8	—
	HSM507L-20	6.5	—
	HSM507L-14	8.8	—
39 - 40	HSM507L-25	5.8	—
	HSM507L-20	6.8	—
	HSM507L-14	8.8	—
41	HSM415K-25	4.8	—
	HSM415K-20	5.4	—
	HSM415K-14	7.0	—
42 - 44	HSM415K-25	4.9	—
	HSM415K-20	5.4	—
	HSM415K-14	7.0	—
45 - 50	HSM415K-25	4.8	—
	HSM415K-20	5.4	—
	HSM415K-14	7.0	—
51 - 55	HSM415K-25	4.9	—
	HSM415K-20	5.4	—
	HSM415K-14	7.1	—

OUTPUT RPM	GEARBOX SIZE†	MIN INPUT SHAFT SHEAVE P.D. (in.)	COOLING METHOD
75 HP Motor (cont.)			
56 - 59	HSM415K-25	4.9	—
	HSM415K-20	5.4	—
	HSM415K-14	7.2	—
60 - 70	HSM407S-25	3.9	—
	HSM407S-20	4.4	—
	HSM407S-14	5.7	—
71 - 73	HSM407S-25	4.0	—
	HSM407S-20	4.5	—
	HSM407S-14	5.9	—
74 - 76	HSM407S-25	4.1	—
	HSM407S-20	4.7	—
	HSM407S-14	6.0	—
77	HSM407S-25	4.2	—
	HSM407S-20	4.7	—
	HSM407S-14	6.1	—
78	HSM407S-25	4.2	—
	HSM407S-20	4.8	—
	HSM407S-14	6.2	—
79 - 82	HSM407S-14	6.2	—
83 - 87	HSM315J-14	6.3	—
88 - 99	HSM315J-14	6.4	—
100	HSM315J-14	6.4	—
	HSM315J-05	11.8	—
101 - 102	HSM315J-05	11.8	—
103 - 111	HSM315J-05	11.7	—
112 - 126	HSM315J-05	11.5	—
127 - 154	HSM315J-05	11.3	—
155 - 175	HSM315J-05	11.2	—
176 - 277	HSM307H-05	7.8	—
278 - 301	HSM307H-05	7.9	—
302 - 366	HSM215G-05	9.4	—
367 - 400	HSM215G-05	9.6	—
100 HP Motor			
17	HSM608M-25	9.8	—
	HSM608M-20	11.5	—
	HSM608M-14	17.0	—
18 - 19	HSM608M-25	9.8	—
	HSM608M-20	11.3	—
	HSM608M-14	17.0	—
20 - 23	HSM608M-25	9.8	—
	HSM608M-20	11.3	—
	HSM608M-14	16.8	—
24 - 28	HSM608M-25	10.0	—
	HSM608M-20	11.0	—
	HSM608M-14	16.5	—
29	HSM608M-25	10.3	—
	HSM608M-20	11.3	—
	HSM608M-14	16.3	—
30	HSM507L-25	5.3	—
	HSM507L-20	6.3	—
	HSM507L-14	8.8	—
31 - 32	HSM507L-25	5.5	—
	HSM507L-20	6.3	—
	HSM507L-14	8.8	—
33 - 34	HSM507L-25	5.5	—
	HSM507L-20	6.5	—
	HSM507L-14	8.8	—
35 - 38	HSM507L-25	5.8	—
	HSM507L-20	6.5	—
	HSM507L-14	8.8	—
39 - 46	HSM507L-25	5.8	—
	HSM507L-20	6.8	—

OUTPUT RPM	GEARBOX SIZE†	MIN INPUT SHAFT SHEAVE P.D. (in.)	COOLING METHOD
100 HP Motor (cont.)			
47 - 52	HSM507L-14	8.8	—
	HSM507L-25	6.0	—
	HSM507L-20	7.0	—
	HSM507L-14	9.0	—
53 - 58	HSM507L-25	6.0	—
	HSM507L-20	7.0	—
	HSM507L-14	9.3	—
59 - 60	HSM507L-14	9.3	—
61 - 70	HSM415K-25	5.0	—
	HSM415K-20	5.5	—
	HSM415K-14	7.2	—
71	HSM415K-25	5.1	—
	HSM415K-20	5.6	—
	HSM415K-14	7.4	—
72 - 73	HSM415K-25	5.1	—
	HSM415K-20	5.7	—
	HSM415K-14	7.4	—
74	HSM415K-25	5.2	—
	HSM415K-20	5.8	—
	HSM415K-14	7.5	—
75 - 76	HSM415K-14	7.6	—
77 - 80	HSM415K-14	7.7	—
81 - 85	HSM407S-14	6.3	—
86 - 99	HSM407S-14	6.4	—
100	HSM407S-14	6.3	—
	HSM407S-05	12.1	—
101 - 107	HSM407S-05	12.0	—
108 - 112	HSM407S-05	11.8	—
113 - 125	HSM407S-05	11.7	—
126 - 137	HSM407S-05	11.5	—
138 - 154	HSM315J-05	11.3	—
155 - 257	HSM315J-05	11.2	—
258 - 272	HSM315J-05	11.3	—
273 - 277	HSM307H-05	7.8	—
278 - 356	HSM307H-05	7.9	—
357 - 400	HSM307H-05	8.1	—
125 HP Motor			
22 - 23	HSM608M-25	9.8	—
	HSM608M-20	11.3	—
	HSM608M-14	16.8	—
24 - 28	HSM608M-25	10.0	—
	HSM608M-20	11.0	—
	HSM608M-14	16.5	—
29 - 30	HSM608M-25	10.3	—
	HSM608M-20	11.3	—
	HSM608M-14	16.3	—
31 - 32	HSM608M-25	10.3	—
	HSM608M-20	11.5	—
	HSM608M-14	16.3	—
33 - 34	HSM608M-25	10.5	—
	HSM608M-20	11.5	—
	HSM608M-14	16.0	—
35 - 37	HSM608M-25	10.8	—
	HSM608M-20	12.0	—
	HSM608M-14	16.0	—
38	HSM608M-25	10.8	—
	HSM608M-20	12.0	—
	HSM608M-14	15.8	—
39 - 46	HSM507L-25	5.8	—
	HSM507L-20	6.8	—
	HSM507L-14	8.8	—
47 - 52	HSM507L-25	6.0	—

NOTE: †Consult factory for delivery of units with 9:1 and 20:1 ratios.

CLASS I HSM Speed Reducer Selection (SF = 1.0)

OUTPUT RPM	GEARBOX SIZE†	MIN INPUT SHAFT SHEAVE P.D. (in.)	COOLING METHOD
125 HP Motor (cont.)			
	HSM507L-20	7.0	—
	HSM507L-14	9.0	—
53 - 58	HSM507L-25	6.0	—
	HSM507L-20	7.0	—
	HSM507L-14	9.3	—
59 - 66	HSM507L-14	9.3	—
67 - 77	HSM507L-14	9.5	—
78 - 81	HSM415K-14	7.7	—
82 - 90	HSM415K-14	7.9	—
91 - 98	HSM415K-14	8.1	—
99	HSM415K-14	7.9	—
100	HSM415K-14	7.9	—
	HSM415K-05	16.0	—
101 - 103	HSM415K-05	15.9	—
104 - 105	HSM415K-05	15.7	—
106 - 110	HSM415K-05	15.5	—
111 - 113	HSM415K-05	15.3	—
114 - 116	HSM415K-05	15.2	—
117 - 125	HSM407S-05	11.7	—
126 - 161	HSM407S-05	11.5	—
162 - 199	HSM407S-05	11.3	—
200 - 257	HSM315J-05	11.2	—
258 - 289	HSM315J-05	11.3	—
290 - 338	HSM315J-05	11.5	—
339 - 358	HSM315J-05	11.7	—
359 - 368	HSM315J-05	11.8	—
369 - 374	HSM307H-05	8.1	—
375 - 400	HSM315J-05	11.9	—
150 HP Motor			
26 - 28	HSM608M-25	10.0	—
	HSM608M-20	11.0	—
	HSM608M-14	16.5	—
29 - 30	HSM608M-25	10.3	—
	HSM608M-20	11.3	—
	HSM608M-14	16.3	—
31 - 32	HSM608M-25	10.3	—
	HSM608M-20	11.5	—
	HSM608M-14	16.3	—
33 - 34	HSM608M-25	10.5	—
	HSM608M-20	11.5	—
	HSM608M-14	16.0	—
35 - 37	HSM608M-25	10.8	—
	HSM608M-20	12.0	—
	HSM608M-14	16.0	—
38 - 40	HSM608M-25	10.8	—
	HSM608M-20	12.0	—
	HSM608M-14	15.8	—
41 - 42	HSM608M-25	11.0	—
	HSM608M-20	12.0	—
	HSM608M-14	15.8	—
43 - 46	HSM608M-25	11.3	—
	HSM608M-20	12.5	—
	HSM608M-14	16.0	—

OUTPUT RPM	GEARBOX SIZE†	MIN INPUT SHAFT SHEAVE P.D. (in.)	COOLING METHOD
150 HP Motor (cont.)			
47	HSM608M-25	11.3	—
	HSM608M-20	12.5	—
	HSM608M-14	16.3	—
48 - 52	HSM507L-25	6.0	—
	HSM507L-20	7.0	—
	HSM507L-14	9.0	—
53 - 58	HSM507L-25	6.0	—
	HSM507L-20	7.0	—
	HSM507L-14	9.3	—
59 - 66	HSM507L-14	9.3	—
67 - 79	HSM507L-14	9.5	—
80 - 84	HSM507L-14	8.8	—
85 - 89	HSM507L-14	7.5	—
90 - 93	HSM507L-14	6.5	—
94 - 98	HSM415K-14	8.1	—
99	HSM415K-14	7.9	—
100	HSM415K-14	7.9	—
	HSM415K-05	16.0	—
101 - 103	HSM415K-05	15.9	—
104 - 105	HSM415K-05	15.7	—
106 - 110	HSM415K-05	15.5	—
111 - 113	HSM415K-05	15.3	—
114 - 121	HSM415K-05	15.2	—
122 - 133	HSM415K-05	15.0	—
134 - 145	HSM415K-05	14.8	—
146 - 163	HSM415K-05	14.7	—
164 - 227	HSM407S-05	11.3	—
228 - 233	HSM407S-05	11.2	—
234 - 262	HSM407S-05	11.3	—
263 - 289	HSM315J-05	11.3	—
290 - 338	HSM315J-05	11.5	—
339 - 358	HSM315J-05	11.7	—
359 - 388	HSM315J-05	11.8	—
389 - 399	HSM315J-05	12.0	—
400	HSM315J-05	12.0	Fan
200 HP Motor			
36 - 37	HSM608M-25	10.8	—
	HSM608M-20	12.0	—
	HSM608M-14	16.0	—
38 - 40	HSM608M-25	10.8	—
	HSM608M-20	12.0	—
	HSM608M-14	15.8	—
41 - 42	HSM608M-25	11.0	—
	HSM608M-20	12.0	—
	HSM608M-14	15.8	—
43 - 46	HSM608M-25	11.3	—
	HSM608M-20	12.5	—
	HSM608M-14	16.0	—
47 - 50	HSM608M-25	11.3	—
	HSM608M-20	12.5	—
	HSM608M-14	16.3	—
51 - 52	HSM608M-25	11.3	—
	HSM608M-20	12.8	—

OUTPUT RPM	GEARBOX SIZE†	MIN INPUT SHAFT SHEAVE P.D. (in.)	COOLING METHOD
200 HP Motor (cont.)			
	HSM608M-14	16.5	—
53 - 54	HSM608M-25	11.5	—
	HSM608M-20	12.8	—
	HSM608M-14	16.8	—
55 - 67	HSM608M-14	17.0	—
68 - 79	HSM507L-14	9.5	—
80 - 84	HSM507L-14	8.8	—
85 - 89	HSM507L-14	7.5	—
90 - 94	HSM507L-14	6.5	—
95 - 100	HSM507L-14	6.0	—
167 - 230	HSM415K-05	14.7	—
231 - 255	HSM415K-05	14.5	—
256 - 284	HSM407S-05	11.3	—
285 - 341	HSM407S-05	11.5	—
342 - 362	HSM407S-05	11.7	—
363 - 388	HSM407S-05	11.8	—
389 - 398	HSM315J-05	12.0	Fan
399 - 400	HSM407S-05	12.0	—
250 HP Motor			
47 - 50	HSM608M-25	11.3	—
	HSM608M-20	12.5	—
	HSM608M-14	16.3	—
51 - 52	HSM608M-25	11.3	—
	HSM608M-20	12.8	—
	HSM608M-14	16.5	—
53 - 54	HSM608M-25	11.5	—
	HSM608M-20	12.8	—
	HSM608M-14	16.8	—
55 - 70	HSM608M-14	17.0	—
71 - 79	HSM608M-14	17.3	—
80 - 84	HSM608M-14	15.0	—
85 - 88	HSM608M-14	12.8	—
89	HSM608M-14	12.8	Fan
90	HSM608M-14	11.0	Fan
91 - 94	HSM507L-14	6.5	—
95 - 100	HSM507L-14	6.0	—
237 - 281	HSM415K-05	14.5	—
282 - 297	HSM415K-05	14.7	—
298 - 325	HSM415K-05	14.8	—
326 - 347	HSM415K-05	15.0	—
348 - 362	HSM407S-05	11.7	—
363 - 381	HSM407S-05	11.8	—
382 - 400	HSM407S-05	11.9	Fan
59 - 70	HSM608M-14	17.0	—
71 - 79	HSM608M-14	17.3	—
80 - 84	HSM608M-14	15.0	—
85 - 87	HSM608M-14	12.8	—
88 - 89	HSM608M-14	12.8	Fan
308 - 325	HSM415K-05	14.8	—
326 - 376	HSM415K-05	15.0	—
377 - 383	HSM415K-05	15.2	—
384 - 391	HSM415K-05	15.2	Fan
392 - 400	HSM415K-05	15.3	Fan

NOTE: †Consult factory for delivery of units with 9:1 and 20:1 ratios.

HSM Speed Reducer Selection (SF = 1.4) CLASS II

OUTPUT RPM	GEARBOX SIZE†	MIN INPUT SHAFT SHEAVE P.D. (in.)	COOLING METHOD
1/4 HP Motor			
10 - 11	HSM107C-25	1.4	—
	HSM107C-20	1.6	—
	HSM107C-14	2.4	—
	HSM107C-09	3.5	—
12 - 17	HSM107C-25	1.4	—
	HSM107C-20	1.6	—
	HSM107C-14	2.5	—
	HSM107C-09	3.5	—
18	HSM107C-25	1.5	—
	HSM107C-20	1.7	—
	HSM107C-14	2.5	—
	HSM107C-09	3.5	—
19 - 24	HSM107C-25	1.5	—
	HSM107C-20	1.7	—
	HSM107C-14	2.6	—
	HSM107C-09	3.5	—
25 - 26	HSM107C-25	1.6	—
	HSM107C-20	1.7	—
	HSM107C-14	2.6	—
	HSM107C-09	3.4	—
27 - 36	HSM107C-25	1.6	—
	HSM107C-20	1.8	—
	HSM107C-14	2.6	—
	HSM107C-09	3.4	—
37	HSM107C-25	1.8	—
	HSM107C-20	1.9	—
	HSM107C-14	2.5	—
	HSM107C-09	3.4	—
38	HSM107C-25	1.8	—
	HSM107C-20	1.9	—
	HSM107C-14	2.5	—
	HSM107C-09	3.3	—
39	HSM107C-25	1.8	—
	HSM107C-20	1.9	—
	HSM107C-14	2.6	—
	HSM107C-09	3.3	—
40 - 65	HSM107C-25	1.8	—
	HSM107C-20	2.0	—
	HSM107C-14	2.6	—
	HSM107C-09	3.3	—
66 - 68	HSM107C-25	1.9	—
	HSM107C-20	2.0	—
	HSM107C-14	2.7	—
	HSM107C-09	3.3	—
69 - 70	HSM107C-25	1.9	—
	HSM107C-20	2.0	—
	HSM107C-14	2.7	—
	HSM107C-09	3.4	—
71 - 74	HSM107C-25	1.9	—
	HSM107C-20	2.1	—
	HSM107C-14	2.7	—
	HSM107C-09	3.4	—
75	HSM107C-25	1.9	—
	HSM107C-20	2.1	—
	HSM107C-14	2.8	—
	HSM107C-09	3.5	—
76	HSM107C-25	2.0	—
	HSM107C-20	2.1	—
	HSM107C-14	2.8	—
	HSM107C-09	3.4	—

OUTPUT RPM	GEARBOX SIZE†	MIN INPUT SHAFT SHEAVE P.D. (in.)	COOLING METHOD
1/4 HP Motor (cont.)			
77 - 79	HSM107C-25	2.0	—
	HSM107C-20	2.2	—
	HSM107C-14	2.8	—
	HSM107C-09	3.4	—
80	HSM107C-25	2.0	—
	HSM107C-20	2.2	—
	HSM107C-14	2.9	—
	HSM107C-09	3.4	—
81 - 83	HSM107C-25	2.0	—
	HSM107C-20	2.2	—
	HSM107C-14	2.9	—
	HSM107C-09	3.5	—
84 - 86	HSM107C-25	2.1	—
	HSM107C-20	2.2	—
	HSM107C-14	2.9	—
	HSM107C-09	3.5	—
87 - 90	HSM107C-20	2.3	—
	HSM107C-14	2.9	—
	HSM107C-09	3.5	—
91 - 93	HSM107C-20	2.3	—
	HSM107C-14	3.0	—
	HSM107C-09	3.5	—
94 - 97	HSM107C-20	2.3	—
	HSM107C-14	3.0	—
	HSM107C-09	3.6	—
98 - 99	HSM107C-20	2.3	—
	HSM107C-14	2.9	—
	HSM107C-09	3.7	—
100	HSM107C-14	2.9	—
	HSM107C-09	3.7	—
	HSM107C-05	5.6	—
101 - 102	HSM107C-09	3.7	—
	HSM107C-05	5.5	—
103 - 116	HSM107C-09	3.6	—
	HSM107C-05	5.5	—
117 - 220	HSM107C-09	3.6	—
	HSM107C-05	5.3	—
221 - 328	HSM107C-05	5.2	—
329 - 400	HSM107C-05	5.4	—
1/3 HP Motor			
10 - 11	HSM107C-25	1.4	—
	HSM107C-20	1.6	—
	HSM107C-14	2.4	—
	HSM107C-09	3.5	—
12 - 17	HSM107C-25	1.4	—
	HSM107C-20	1.6	—
	HSM107C-14	2.5	—
	HSM107C-09	3.5	—
18	HSM107C-25	1.5	—
	HSM107C-20	1.7	—
	HSM107C-14	2.5	—
	HSM107C-09	3.5	—
19 - 24	HSM107C-25	1.5	—
	HSM107C-20	1.7	—
	HSM107C-14	2.6	—
	HSM107C-09	3.5	—
25 - 26	HSM107C-25	1.6	—
	HSM107C-20	1.7	—
	HSM107C-14	2.6	—
	HSM107C-09	3.4	—

OUTPUT RPM	GEARBOX SIZE†	MIN INPUT SHAFT SHEAVE P.D. (in.)	COOLING METHOD
1/3 HP Motor (cont.)			
27 - 36	HSM107C-25	1.6	—
	HSM107C-20	1.8	—
	HSM107C-14	2.6	—
	HSM107C-09	3.4	—
37	HSM107C-25	1.8	—
	HSM107C-20	1.9	—
	HSM107C-14	2.5	—
	HSM107C-09	3.4	—
38	HSM107C-25	1.8	—
	HSM107C-20	1.9	—
	HSM107C-14	2.5	—
	HSM107C-09	3.3	—
39	HSM107C-25	1.8	—
	HSM107C-20	1.9	—
	HSM107C-14	2.6	—
	HSM107C-09	3.3	—
40 - 65	HSM107C-25	1.8	—
	HSM107C-20	2.0	—
	HSM107C-14	2.6	—
	HSM107C-09	3.3	—
66 - 68	HSM107C-25	1.9	—
	HSM107C-20	2.0	—
	HSM107C-14	2.7	—
	HSM107C-09	3.3	—
69 - 70	HSM107C-25	1.9	—
	HSM107C-20	2.0	—
	HSM107C-14	2.7	—
	HSM107C-09	3.4	—
71 - 74	HSM107C-25	1.9	—
	HSM107C-20	2.1	—
	HSM107C-14	2.7	—
	HSM107C-09	3.4	—
75	HSM107C-25	1.9	—
	HSM107C-20	2.1	—
	HSM107C-14	2.8	—
	HSM107C-09	3.5	—
76	HSM107C-25	2.0	—
	HSM107C-20	2.1	—
	HSM107C-14	2.8	—
	HSM107C-09	3.4	—
77 - 79	HSM107C-25	2.0	—
	HSM107C-20	2.2	—
	HSM107C-14	2.8	—
	HSM107C-09	3.4	—
80	HSM107C-25	2.0	—
	HSM107C-20	2.2	—
	HSM107C-14	2.9	—
	HSM107C-09	3.4	—
81 - 83	HSM107C-25	2.0	—
	HSM107C-20	2.2	—
	HSM107C-14	2.9	—
	HSM107C-09	3.5	—
84 - 86	HSM107C-25	2.1	—
	HSM107C-20	2.2	—
	HSM107C-14	2.9	—
	HSM107C-09	3.5	—
87 - 90	HSM107C-20	2.3	—
	HSM107C-14	2.9	—
	HSM107C-09	3.5	—
91 - 93	HSM107C-20	2.3	—

NOTE: †Consult factory for delivery of units with 9:1 and 20:1 ratios.

CLASS II HSM Speed Reducer Selection (SF = 1.4)

OUTPUT RPM	GEARBOX SIZE†	MIN INPUT SHAFT SHEAVE P.D. (in.)	COOLING METHOD
1/3 HP Motor (cont.)			
91 - 93	HSM107C-14	3.0	—
	HSM107C-09	3.5	—
94 - 97	HSM107C-20	2.3	—
	HSM107C-14	3.0	—
	HSM107C-09	3.6	—
98 - 99	HSM107C-20	2.3	—
	HSM107C-14	2.9	—
	HSM107C-09	3.7	—
100	HSM107C-14	2.9	—
	HSM107C-09	3.7	—
	HSM107C-05	5.6	—
101 - 102	HSM107C-09	3.7	—
	HSM107C-05	5.5	—
103 - 116	HSM107C-09	3.6	—
	HSM107C-05	5.5	—
117 - 220	HSM107C-09	3.6	—
	HSM107C-05	5.3	—
221 - 328	HSM107C-05	5.2	—
329 - 400	HSM107C-05	5.4	—
1/2 HP Motor			
10 - 11	HSM107C-25	1.4	—
	HSM107C-20	1.6	—
	HSM107C-14	2.4	—
	HSM107C-09	3.5	—
12 - 17	HSM107C-25	1.4	—
	HSM107C-20	1.6	—
	HSM107C-14	2.5	—
	HSM107C-09	3.5	—
18	HSM107C-25	1.5	—
	HSM107C-20	1.7	—
	HSM107C-14	2.5	—
	HSM107C-09	3.5	—
19 - 24	HSM107C-25	1.5	—
	HSM107C-20	1.7	—
	HSM107C-14	2.6	—
	HSM107C-09	3.5	—
25 - 26	HSM107C-25	1.6	—
	HSM107C-20	1.7	—
	HSM107C-14	2.6	—
	HSM107C-09	3.4	—
27 - 36	HSM107C-25	1.6	—
	HSM107C-20	1.8	—
	HSM107C-14	2.6	—
	HSM107C-09	3.4	—
37	HSM107C-25	1.8	—
	HSM107C-20	1.9	—
	HSM107C-14	2.5	—
	HSM107C-09	3.4	—
38	HSM107C-25	1.8	—
	HSM107C-20	1.9	—
	HSM107C-14	2.5	—
	HSM107C-09	3.3	—
39	HSM107C-25	1.8	—
	HSM107C-20	1.9	—
	HSM107C-14	2.6	—
	HSM107C-09	3.3	—
40 - 65	HSM107C-25	1.8	—
	HSM107C-20	2.0	—
	HSM107C-14	2.6	—
	HSM107C-09	3.3	—

OUTPUT RPM	GEARBOX SIZE†	MIN INPUT SHAFT SHEAVE P.D. (in.)	COOLING METHOD
1/2 HP Motor (cont.)			
66 - 68	HSM107C-25	1.9	—
	HSM107C-20	2.0	—
	HSM107C-14	2.7	—
	HSM107C-09	3.3	—
69 - 70	HSM107C-25	1.9	—
	HSM107C-20	2.0	—
	HSM107C-14	2.7	—
	HSM107C-09	3.4	—
71 - 74	HSM107C-25	1.9	—
	HSM107C-20	2.1	—
	HSM107C-14	2.7	—
	HSM107C-09	3.4	—
75	HSM107C-25	1.9	—
	HSM107C-20	2.1	—
	HSM107C-14	2.8	—
	HSM107C-09	3.5	—
76	HSM107C-25	2.0	—
	HSM107C-20	2.1	—
	HSM107C-14	2.8	—
	HSM107C-09	3.4	—
77 - 79	HSM107C-25	2.0	—
	HSM107C-20	2.2	—
	HSM107C-14	2.8	—
	HSM107C-09	3.4	—
80	HSM107C-25	2.0	—
	HSM107C-20	2.2	—
	HSM107C-14	2.9	—
	HSM107C-09	3.4	—
81 - 83	HSM107C-25	2.0	—
	HSM107C-20	2.2	—
	HSM107C-14	2.9	—
	HSM107C-09	3.5	—
84 - 86	HSM107C-25	2.1	—
	HSM107C-20	2.2	—
	HSM107C-14	2.9	—
	HSM107C-09	3.5	—
87 - 90	HSM107C-20	2.3	—
	HSM107C-14	2.9	—
	HSM107C-09	3.5	—
91 - 93	HSM107C-20	2.3	—
	HSM107C-14	3.0	—
	HSM107C-09	3.5	—
94 - 97	HSM107C-20	2.3	—
	HSM107C-14	3.0	—
	HSM107C-09	3.6	—
98 - 99	HSM107C-20	2.3	—
	HSM107C-14	2.9	—
	HSM107C-09	3.7	—
100	HSM107C-14	2.9	—
	HSM107C-09	3.7	—
	HSM107C-05	5.6	—
101 - 102	HSM107C-09	3.7	—
	HSM107C-05	5.5	—
103 - 116	HSM107C-09	3.6	—
	HSM107C-05	5.5	—
117 - 220	HSM107C-09	3.6	—
	HSM107C-05	5.3	—
221 - 328	HSM107C-05	5.2	—
329 - 400	HSM107C-05	5.4	—

OUTPUT RPM	GEARBOX SIZE†	MIN INPUT SHAFT SHEAVE P.D. (in.)	COOLING METHOD
3/4 HP Motor			
10	HSM115D-25	1.9	—
	HSM115D-20	2.1	—
	HSM115D-14	3.2	—
	HSM115D-09	4.9	—
11 - 13	HSM115D-25	1.9	—
	HSM115D-20	2.2	—
	HSM115D-14	3.3	—
	HSM115D-09	5.0	—
14	HSM107C-25	1.4	—
	HSM107C-20	1.6	—
	HSM107C-14	2.5	—
	HSM115D-09	5.1	—
15 - 17	HSM107C-25	1.4	—
	HSM107C-20	1.6	—
	HSM107C-14	2.5	—
	HSM107C-09	3.5	—
18	HSM107C-25	1.5	—
	HSM107C-20	1.7	—
	HSM107C-14	2.5	—
	HSM107C-09	3.5	—
19 - 24	HSM107C-25	1.5	—
	HSM107C-20	1.7	—
	HSM107C-14	2.6	—
	HSM107C-09	3.5	—
25 - 26	HSM107C-25	1.6	—
	HSM107C-20	1.7	—
	HSM107C-14	2.6	—
	HSM107C-09	3.4	—
27 - 36	HSM107C-25	1.6	—
	HSM107C-20	1.8	—
	HSM107C-14	2.6	—
	HSM107C-09	3.4	—
37	HSM107C-25	1.8	—
	HSM107C-20	1.9	—
	HSM107C-14	2.5	—
	HSM107C-09	3.4	—
38	HSM107C-25	1.8	—
	HSM107C-20	1.9	—
	HSM107C-14	2.5	—
	HSM107C-09	3.3	—
39	HSM107C-25	1.8	—
	HSM107C-20	1.9	—
	HSM107C-14	2.6	—
	HSM107C-09	3.3	—
40 - 65	HSM107C-25	1.8	—
	HSM107C-20	2.0	—
	HSM107C-14	2.6	—
	HSM107C-09	3.3	—
66 - 68	HSM107C-25	1.9	—
	HSM107C-20	2.0	—
	HSM107C-14	2.7	—
	HSM107C-09	3.3	—
69 - 70	HSM107C-25	1.9	—
	HSM107C-20	2.0	—
	HSM107C-14	2.7	—
	HSM107C-09	3.4	—
71 - 74	HSM107C-25	1.9	—
	HSM107C-20	2.1	—
	HSM107C-14	2.7	—
	HSM107C-09	3.4	—

NOTE: †Consult factory for delivery of units with 9:1 and 20:1 ratios.

HSM Speed Reducer Selection (SF = 1.4) CLASS II

OUTPUT RPM	GEARBOX SIZE†	MIN INPUT SHAFT SHEAVE P.D. (in.)	COOLING METHOD
3/4 HP Motor (cont.)			
75	HSM107C-25	1.9	—
	HSM107C-20	2.1	—
76	HSM107C-14	2.8	—
	HSM107C-09	3.5	—
	HSM107C-25	2.0	—
77 - 79	HSM107C-20	2.1	—
	HSM107C-14	2.8	—
	HSM107C-09	3.4	—
80	HSM107C-25	2.0	—
	HSM107C-20	2.2	—
	HSM107C-14	2.9	—
81 - 83	HSM107C-09	3.4	—
	HSM107C-25	2.0	—
	HSM107C-20	2.2	—
84 - 86	HSM107C-14	2.9	—
	HSM107C-09	3.5	—
	HSM107C-25	2.1	—
87 - 90	HSM107C-20	2.2	—
	HSM107C-14	2.9	—
	HSM107C-09	3.5	—
91 - 93	HSM107C-20	2.3	—
	HSM107C-14	3.0	—
	HSM107C-09	3.5	—
94 - 97	HSM107C-20	2.3	—
	HSM107C-14	3.0	—
	HSM107C-09	3.6	—
98 - 99	HSM107C-20	2.3	—
	HSM107C-14	2.9	—
	HSM107C-09	3.7	—
100	HSM107C-14	2.9	—
	HSM107C-09	3.7	—
	HSM107C-05	5.6	—
101 - 102	HSM107C-09	3.7	—
	HSM107C-05	5.5	—
103 - 116	HSM107C-09	3.6	—
	HSM107C-05	5.5	—
117 - 220	HSM107C-09	3.6	—
	HSM107C-05	5.3	—
221 - 328	HSM107C-05	5.2	—
329 - 400	HSM107C-05	5.4	—
1 HP Motor			
10	HSM203E-25	2.1	—
	HSM203E-20	2.5	—
	HSM203E-14	3.8	—
11 - 12	HSM203E-09	5.7	—
	HSM203E-25	2.1	—
	HSM203E-20	2.6	—
13 - 14	HSM203E-14	3.9	—
	HSM203E-09	5.7	—
	HSM115D-25	1.9	—
	HSM115D-20	2.2	—
	HSM115D-14	3.3	—
	HSM115D-09	5.0	—

OUTPUT RPM	GEARBOX SIZE†	MIN INPUT SHAFT SHEAVE P.D. (in.)	COOLING METHOD
1 HP Motor (cont.)			
15	HSM115D-25	1.9	—
	HSM115D-20	2.2	—
16	HSM115D-14	3.4	—
	HSM115D-09	5.1	—
	HSM115D-25	2.0	—
17 - 18	HSM115D-20	2.3	—
	HSM115D-14	3.4	—
	HSM115D-09	5.1	—
19	HSM115D-25	2.0	—
	HSM115D-20	2.3	—
	HSM115D-14	3.4	—
20 - 24	HSM115D-09	5.2	—
	HSM107C-25	1.5	—
	HSM107C-20	1.7	—
25 - 26	HSM107C-14	2.6	—
	HSM107C-09	3.5	—
	HSM107C-25	1.6	—
27 - 36	HSM107C-20	1.7	—
	HSM107C-14	2.6	—
	HSM107C-09	3.4	—
37	HSM107C-25	1.6	—
	HSM107C-20	1.8	—
	HSM107C-14	2.6	—
38	HSM107C-09	3.4	—
	HSM107C-25	1.8	—
	HSM107C-20	1.9	—
39	HSM107C-14	2.5	—
	HSM107C-09	3.4	—
	HSM107C-25	1.8	—
40 - 65	HSM107C-20	1.9	—
	HSM107C-14	2.6	—
	HSM107C-09	3.3	—
66 - 68	HSM107C-25	1.8	—
	HSM107C-20	2.0	—
	HSM107C-14	2.7	—
69 - 70	HSM107C-09	3.3	—
	HSM107C-25	1.9	—
	HSM107C-20	2.0	—
71 - 74	HSM107C-14	2.7	—
	HSM107C-09	3.4	—
	HSM107C-25	1.9	—
75	HSM107C-20	2.1	—
	HSM107C-14	2.7	—
	HSM107C-09	3.4	—
	HSM107C-25	1.9	—
	HSM107C-20	2.1	—
	HSM107C-14	2.8	—
	HSM107C-09	3.5	—

OUTPUT RPM	GEARBOX SIZE†	MIN INPUT SHAFT SHEAVE P.D. (in.)	COOLING METHOD
1 HP Motor (cont.)			
76	HSM107C-25	2.0	—
	HSM107C-20	2.1	—
77 - 79	HSM107C-14	2.8	—
	HSM107C-09	3.4	—
	HSM107C-25	2.0	—
80	HSM107C-20	2.2	—
	HSM107C-14	2.8	—
	HSM107C-09	3.4	—
81 - 83	HSM107C-25	2.0	—
	HSM107C-20	2.2	—
	HSM107C-14	2.9	—
84 - 86	HSM107C-09	3.5	—
	HSM107C-25	2.1	—
	HSM107C-20	2.2	—
87 - 90	HSM107C-14	2.9	—
	HSM107C-09	3.5	—
	HSM107C-20	2.3	—
91 - 93	HSM107C-14	2.9	—
	HSM107C-09	3.5	—
	HSM107C-20	2.3	—
94 - 97	HSM107C-14	3.0	—
	HSM107C-09	3.6	—
	HSM107C-20	2.3	—
98 - 99	HSM107C-14	2.9	—
	HSM107C-09	3.7	—
	HSM107C-20	2.3	—
100	HSM107C-14	2.9	—
	HSM107C-09	3.7	—
	HSM107C-05	5.6	—
101 - 102	HSM107C-09	3.7	—
	HSM107C-05	5.5	—
103 - 116	HSM107C-09	3.6	—
	HSM107C-05	5.5	—
117 - 220	HSM107C-09	3.6	—
	HSM107C-05	5.3	—
221 - 328	HSM107C-05	5.2	—
329 - 400	HSM107C-05	5.4	—
1 1/2 HP Motor			
10 - 11	HSM207F-25	1.6	—
	HSM207F-20	2.0	—
	HSM207F-14	3.0	—
12 - 14	HSM203E-25	2.1	—
	HSM203E-20	2.6	—
	HSM203E-14	3.9	—
15	HSM203E-09	5.8	—
	HSM203E-25	2.1	—
	HSM203E-20	2.6	—
16	HSM203E-14	4.0	—
	HSM203E-09	5.8	—
	HSM203E-25	2.1	—
17	HSM203E-20	2.7	—
	HSM203E-14	4.0	—
	HSM203E-09	5.8	—
	HSM203E-25	2.2	—

NOTE: †Consult factory for delivery of units with 9:1 and 20:1 ratios.

CLASS II HSM Speed Reducer Selection (SF = 1.4)

OUTPUT RPM	GEARBOX SIZE†	MIN INPUT SHAFT SHEAVE P.D. (in.)	COOLING METHOD
1 1/2 HP Motor (cont.)			
17	HSM203E-20	2.7	—
	HSM203E-14	4.0	—
	HSM203E-09	5.8	—
18 - 19	HSM115D-25	2.0	—
	HSM115D-20	2.3	—
	HSM115D-14	3.4	—
	HSM115D-09	5.2	—
20 - 22	HSM115D-25	2.0	—
	HSM115D-20	2.3	—
	HSM115D-14	3.5	—
	HSM115D-09	5.2	—
23 - 25	HSM115D-25	2.1	—
	HSM115D-20	2.3	—
	HSM115D-14	3.5	—
	HSM115D-09	5.3	—
26	HSM115D-25	2.2	—
	HSM115D-20	2.4	—
	HSM115D-14	3.5	—
	HSM115D-09	5.3	—
27 - 30	HSM107C-25	1.6	—
	HSM107C-20	1.8	—
	HSM107C-14	2.6	—
	HSM115D-09	5.3	—
31 - 36	HSM107C-25	1.7	—
	HSM107C-20	1.8	—
	HSM107C-14	2.6	—
	HSM107C-09	3.4	—
37	HSM107C-25	1.8	—
	HSM107C-20	1.9	—
	HSM107C-14	2.5	—
	HSM107C-09	3.4	—
38	HSM107C-25	1.8	—
	HSM107C-20	1.9	—
	HSM107C-14	2.5	—
	HSM107C-09	3.3	—
39	HSM107C-25	1.8	—
	HSM107C-20	1.9	—
	HSM107C-14	2.6	—
	HSM107C-09	3.3	—
40 - 65	HSM107C-25	1.8	—
	HSM107C-20	2.0	—
	HSM107C-14	2.6	—
	HSM107C-09	3.3	—
66 - 68	HSM107C-25	1.9	—
	HSM107C-20	2.0	—
	HSM107C-14	2.7	—
	HSM107C-09	3.3	—
69 - 70	HSM107C-25	1.9	—
	HSM107C-20	2.0	—
	HSM107C-14	2.7	—
	HSM107C-09	3.4	—
71 - 74	HSM107C-25	1.9	—
	HSM107C-20	2.1	—
	HSM107C-14	2.7	—
	HSM107C-09	3.4	—
75	HSM107C-25	1.9	—
	HSM107C-20	2.1	—
	HSM107C-14	2.8	—
	HSM107C-09	3.5	—
76	HSM107C-25	2.0	—

OUTPUT RPM	GEARBOX SIZE†	MIN INPUT SHAFT SHEAVE P.D. (in.)	COOLING METHOD
1 1/2 HP Motor (cont.)			
76	HSM107C-20	2.1	—
	HSM107C-14	2.8	—
	HSM107C-09	3.4	—
77 - 79	HSM107C-25	2.0	—
	HSM107C-20	2.2	—
	HSM107C-14	2.8	—
	HSM107C-09	3.4	—
80	HSM107C-25	2.0	—
	HSM107C-20	2.2	—
	HSM107C-14	2.9	—
	HSM107C-09	3.4	—
81 - 83	HSM107C-25	2.0	—
	HSM107C-20	2.2	—
	HSM107C-14	2.9	—
	HSM107C-09	3.5	—
84 - 86	HSM107C-25	2.1	—
	HSM107C-20	2.2	—
	HSM107C-14	2.9	—
	HSM107C-09	3.5	—
87 - 90	HSM107C-20	2.3	—
	HSM107C-14	2.9	—
	HSM107C-09	3.5	—
91 - 93	HSM107C-20	2.3	—
	HSM107C-14	3.0	—
	HSM107C-09	3.5	—
94 - 97	HSM107C-20	2.3	—
	HSM107C-14	3.0	—
	HSM107C-09	3.6	—
98 - 99	HSM107C-20	2.3	—
	HSM107C-14	2.9	—
	HSM107C-09	3.7	—
100	HSM107C-14	2.9	—
	HSM107C-09	3.7	—
	HSM107C-05	5.6	—
101 - 102	HSM107C-09	3.7	—
	HSM107C-05	5.5	—
103 - 116	HSM107C-09	3.6	—
	HSM107C-05	5.5	—
117 - 220	HSM107C-09	3.6	—
	HSM107C-05	5.3	—
221 - 328	HSM107C-05	5.2	—
329 - 400	HSM107C-05	5.4	—
2 HP Motor			
10	HSM215G-25	2.3	—
	HSM215G-20	2.8	—
	HSM215G-14	4.3	—
11 - 12	HSM207F-25	1.6	—
	HSM207F-20	2.0	—
	HSM207F-14	3.0	—
13	HSM207F-25	1.7	—
	HSM207F-20	2.0	—
	HSM207F-14	3.1	—
14	HSM207F-25	1.7	—
	HSM207F-20	2.1	—
	HSM207F-14	3.1	—
15	HSM203E-25	2.1	—
	HSM203E-20	2.6	—
	HSM203E-14	4.0	—
16	HSM203E-25	2.1	—
	HSM203E-20	2.7	—

OUTPUT RPM	GEARBOX SIZE†	MIN INPUT SHAFT SHEAVE P.D. (in.)	COOLING METHOD
2 HP Motor (cont.)			
16	HSM203E-14	4.0	—
	HSM203E-09	5.8	—
17 - 22	HSM203E-25	2.2	—
	HSM203E-20	2.7	—
	HSM203E-14	4.0	—
	HSM203E-09	5.8	—
23 - 25	HSM115D-25	2.1	—
	HSM115D-20	2.3	—
	HSM115D-14	3.5	—
	HSM115D-09	5.3	—
26 - 28	HSM115D-25	2.2	—
	HSM115D-20	2.4	—
	HSM115D-14	3.5	—
	HSM115D-09	5.3	—
29 - 33	HSM115D-25	2.3	—
	HSM115D-20	2.5	—
	HSM115D-14	3.5	—
	HSM115D-09	5.3	—
34	HSM115D-25	2.4	—
	HSM115D-20	2.6	—
	HSM115D-14	3.5	—
	HSM115D-09	5.2	—
35 - 36	HSM115D-25	2.4	—
	HSM115D-20	2.6	—
	HSM115D-14	3.4	—
	HSM115D-09	5.2	—
37 - 38	HSM107C-25	1.8	—
	HSM107C-20	1.9	—
	HSM107C-14	2.5	—
	HSM115D-09	5.2	—
39	HSM107C-25	1.8	—
	HSM107C-20	1.9	—
	HSM107C-14	2.6	—
	HSM115D-09	5.1	—
40 - 41	HSM107C-25	1.8	—
	HSM107C-20	2.0	—
	HSM107C-14	2.6	—
	HSM115D-09	5.1	—
42 - 65	HSM107C-25	1.8	—
	HSM107C-20	2.0	—
	HSM107C-14	2.6	—
	HSM107C-09	3.3	—
66 - 68	HSM107C-25	1.9	—
	HSM107C-20	2.0	—
	HSM107C-14	2.7	—
	HSM107C-09	3.3	—
69 - 70	HSM107C-25	1.9	—
	HSM107C-20	2.0	—
	HSM107C-14	2.7	—
	HSM107C-09	3.4	—
71 - 74	HSM107C-25	1.9	—
	HSM107C-20	2.1	—
	HSM107C-14	2.7	—
	HSM107C-09	3.4	—
75	HSM107C-25	1.9	—
	HSM107C-20	2.1	—
	HSM107C-14	2.8	—
	HSM107C-09	3.5	—
76	HSM107C-25	2.0	—
	HSM107C-20	2.1	—

NOTE: †Consult factory for delivery of units with 9:1 and 20:1 ratios.

HSM Speed Reducer Selection (SF = 1.4) CLASS II

OUTPUT RPM	GEARBOX SIZE†	MIN INPUT SHAFT SHEAVE P.D. (in.)	COOLING METHOD
2 HP Motor (cont.)			
76	HSM107C-14	2.8	—
	HSM107C-09	3.4	—
77 - 79	HSM107C-25	2.0	—
	HSM107C-20	2.2	—
	HSM107C-14	2.8	—
	HSM107C-09	3.4	—
80	HSM107C-25	2.0	—
	HSM107C-20	2.2	—
	HSM107C-14	2.9	—
	HSM107C-09	3.4	—
81 - 83	HSM107C-25	2.0	—
	HSM107C-20	2.2	—
	HSM107C-14	2.9	—
	HSM107C-09	3.5	—
84 - 86	HSM107C-25	2.1	—
	HSM107C-20	2.2	—
	HSM107C-14	2.9	—
	HSM107C-09	3.5	—
87 - 90	HSM107C-20	2.3	—
	HSM107C-14	2.9	—
	HSM107C-09	3.5	—
91 - 93	HSM107C-20	2.3	—
	HSM107C-14	3.0	—
	HSM107C-09	3.5	—
94 - 97	HSM107C-20	2.3	—
	HSM107C-14	3.0	—
	HSM107C-09	3.6	—
98 - 99	HSM107C-20	2.3	—
	HSM107C-14	2.9	—
	HSM107C-09	3.7	—
100	HSM107C-14	2.9	—
	HSM107C-09	3.7	—
	HSM107C-05	5.6	—
101 - 102	HSM107C-09	3.7	—
	HSM107C-05	5.5	—
103 - 116	HSM107C-09	3.6	—
	HSM107C-05	5.5	—
117 - 220	HSM107C-09	3.6	—
	HSM107C-05	5.3	—
221 - 328	HSM107C-05	5.2	—
329 - 400	HSM107C-05	5.4	—
3 HP Motor			
10	HSM215G-25	2.3	—
	HSM215G-20	2.8	—
	HSM215G-14	4.3	—
11 - 12	HSM215G-25	2.3	—
	HSM215G-20	2.9	—
	HSM215G-14	4.4	—
13 - 14	HSM215G-25	2.4	—
	HSM215G-20	2.9	—
	HSM215G-14	4.5	—
15	HSM215G-25	2.4	—
	HSM215G-20	3.0	—
	HSM215G-14	4.5	—
16 - 17	HSM207F-25	1.7	—
	HSM207F-20	2.1	—
	HSM207F-14	3.1	—
18 - 21	HSM207F-25	1.7	—
	HSM207F-20	2.1	—
	HSM207F-14	3.2	—

OUTPUT RPM	GEARBOX SIZE†	MIN INPUT SHAFT SHEAVE P.D. (in.)	COOLING METHOD
3 HP Motor (cont.)			
22 - 23	HSM203E-25	2.3	—
	HSM203E-20	2.7	—
	HSM203E-14	4.1	—
24	HSM203E-25	2.3	—
	HSM203E-20	2.7	—
	HSM203E-14	4.1	—
	HSM203E-09	5.7	—
25 - 26	HSM203E-25	2.4	—
	HSM203E-20	2.7	—
	HSM203E-14	4.1	—
	HSM203E-09	5.7	—
27	HSM203E-25	2.5	—
	HSM203E-20	2.8	—
	HSM203E-14	4.1	—
	HSM203E-09	5.7	—
28	HSM203E-25	2.5	—
	HSM203E-20	2.9	—
	HSM203E-14	4.1	—
	HSM203E-09	5.6	—
29 - 30	HSM203E-25	2.6	—
	HSM203E-20	2.9	—
	HSM203E-14	4.1	—
	HSM203E-09	5.6	—
31 - 33	HSM203E-25	2.6	—
	HSM203E-20	3.0	—
	HSM203E-14	4.1	—
	HSM203E-09	5.7	—
34	HSM203E-25	2.7	—
	HSM203E-20	3.0	—
	HSM203E-14	4.1	—
	HSM203E-09	5.8	—
35 - 38	HSM115D-25	2.4	—
	HSM115D-20	2.6	—
	HSM115D-14	3.4	—
	HSM115D-09	5.2	—
39	HSM115D-25	2.4	—
	HSM115D-20	2.7	—
	HSM115D-14	3.4	—
	HSM115D-09	5.1	—
40	HSM115D-25	2.4	—
	HSM115D-20	2.7	—
	HSM115D-14	3.5	—
	HSM115D-09	5.1	—
41 - 44	HSM115D-25	2.4	—
	HSM115D-20	2.7	—
	HSM115D-14	3.4	—
	HSM115D-09	5.1	—
45	HSM115D-25	2.4	—
	HSM115D-20	2.7	—
	HSM115D-14	3.4	—
	HSM115D-09	4.9	—
46 - 47	HSM115D-25	2.4	—
	HSM115D-20	2.7	—
	HSM115D-14	3.5	—
	HSM115D-09	4.9	—
48 - 49	HSM115D-25	2.4	—
	HSM115D-20	2.7	—
	HSM115D-14	3.5	—
	HSM115D-09	4.8	—
50 - 54	HSM115D-25	2.5	—

OUTPUT RPM	GEARBOX SIZE†	MIN INPUT SHAFT SHEAVE P.D. (in.)	COOLING METHOD
3 HP Motor (cont.)			
50 - 54	HSM115D-20	2.7	—
	HSM115D-14	3.5	—
	HSM115D-09	4.8	—
55 - 61	HSM115D-25	2.5	—
	HSM115D-20	2.7	—
	HSM115D-14	3.5	—
	HSM115D-09	4.6	—
62 - 63	HSM115D-25	2.5	—
	HSM115D-20	2.7	—
	HSM115D-14	3.6	—
	HSM115D-09	4.6	—
64 - 65	HSM107C-25	1.9	—
	HSM107C-20	2.0	—
	HSM107C-14	2.6	—
	HSM115D-09	4.6	—
66 - 68	HSM107C-25	1.9	—
	HSM107C-20	2.0	—
	HSM107C-14	2.7	—
	HSM107C-09	3.3	—
69 - 70	HSM107C-25	1.9	—
	HSM107C-20	2.0	—
	HSM107C-14	2.7	—
	HSM107C-09	3.4	—
71 - 74	HSM107C-25	1.9	—
	HSM107C-20	2.1	—
	HSM107C-14	2.7	—
	HSM107C-09	3.4	—
75	HSM107C-25	1.9	—
	HSM107C-20	2.1	—
	HSM107C-14	2.8	—
	HSM107C-09	3.5	—
76	HSM107C-25	2.0	—
	HSM107C-20	2.1	—
	HSM107C-14	2.8	—
	HSM107C-09	3.4	—
77 - 79	HSM107C-25	2.0	—
	HSM107C-20	2.2	—
	HSM107C-14	2.8	—
	HSM107C-09	3.4	—
80	HSM107C-25	2.0	—
	HSM107C-20	2.2	—
	HSM107C-14	2.9	—
	HSM107C-09	3.4	—
81 - 83	HSM107C-25	2.0	—
	HSM107C-20	2.2	—
	HSM107C-14	2.9	—
	HSM107C-09	3.5	—
84 - 86	HSM107C-25	2.1	—
	HSM107C-20	2.2	—
	HSM107C-14	2.9	—
	HSM107C-09	3.5	—
87 - 90	HSM107C-25	2.3	—
	HSM107C-20	2.9	—
	HSM107C-14	3.5	—
	HSM107C-09	3.5	—
91 - 93	HSM107C-20	2.3	—
	HSM107C-14	3.0	—
	HSM107C-09	3.5	—
94 - 97	HSM107C-20	2.3	—
	HSM107C-14	3.0	—
	HSM107C-09	3.6	—

NOTE: †Consult factory for delivery of units with 9:1 and 20:1 ratios.

CLASS II HSM Speed Reducer Selection (SF = 1.4)

OUTPUT RPM	GEARBOX SIZE†	MIN INPUT SHAFT SHEAVE P.D. (in.)	COOLING METHOD
3 HP Motor (cont.)			
98 - 99	HSM107C-20	2.3	—
	HSM107C-14	2.9	—
	HSM107C-09	3.7	—
100	HSM107C-14	2.9	—
	HSM107C-09	3.7	—
	HSM107C-05	5.6	—
101 - 102	HSM107C-09	3.7	—
	HSM107C-05	5.5	—
103 - 116	HSM107C-09	3.6	—
	HSM107C-05	5.5	—
117 - 220	HSM107C-09	3.6	—
	HSM107C-05	5.3	—
221 - 328	HSM107C-05	5.2	—
329 - 400	HSM107C-05	5.4	—
5 HP Motor			
10	HSM315J-25	2.8	—
	HSM315J-20	3.4	—
	HSM315J-14	5.2	—
11 - 14	HSM307H-25	2.0	—
	HSM307H-20	2.5	—
	HSM307H-14	3.7	—
15 - 20	HSM215G-25	2.4	—
	HSM215G-20	3.0	—
	HSM215G-14	4.5	—
21 - 22	HSM215G-25	2.5	—
	HSM215G-20	3.0	—
	HSM215G-14	4.6	—
23	HSM215G-25	2.6	—
	HSM215G-20	3.0	—
	HSM215G-14	4.6	—
24	HSM215G-25	2.6	—
	HSM215G-20	3.0	—
	HSM215G-14	4.7	—
25	HSM207F-25	1.9	—
	HSM207F-20	2.1	—
	HSM207F-14	3.2	—
26 - 27	HSM207F-25	1.9	—
	HSM207F-20	2.2	—
	HSM207F-14	3.2	—
28 - 33	HSM207F-25	2.0	—
	HSM207F-20	2.2	—
	HSM207F-14	3.2	—
34 - 36	HSM207F-25	2.1	—
	HSM207F-20	2.4	—
	HSM207F-14	3.2	—
37	HSM207F-25	2.1	—
	HSM207F-20	2.4	—
	HSM207F-14	3.1	—
38 - 40	HSM203E-25	2.7	—
	HSM203E-20	3.1	—
	HSM203E-14	4.0	—
41 - 43	HSM203E-25	2.8	—
	HSM203E-20	3.1	—
	HSM203E-14	4.1	—
	HSM203E-09	5.5	—
44 - 48	HSM203E-25	2.8	—
	HSM203E-20	3.2	—
	HSM203E-14	4.1	—
	HSM203E-09	5.4	—
49 - 54	HSM203E-25	2.8	—

OUTPUT RPM	GEARBOX SIZE†	MIN INPUT SHAFT SHEAVE P.D. (in.)	COOLING METHOD
5 HP Motor (cont.)			
49 - 54	HSM203E-20	3.2	—
	HSM203E-14	4.1	—
	HSM203E-09	5.3	—
55 - 59	HSM203E-25	2.8	—
	HSM203E-20	3.2	—
	HSM203E-14	4.2	—
	HSM203E-09	5.3	—
60 - 66	HSM203E-25	2.9	—
	HSM203E-20	3.2	—
	HSM203E-14	4.2	—
	HSM203E-09	5.4	—
67 - 68	HSM203E-25	3.0	—
	HSM203E-20	3.3	—
	HSM203E-14	4.3	—
	HSM203E-09	5.4	—
69 - 71	HSM115D-25	2.6	—
	HSM115D-20	2.8	—
	HSM115D-14	3.6	—
	HSM115D-09	4.7	—
72	HSM115D-25	2.6	—
	HSM115D-20	2.8	—
	HSM115D-14	3.7	—
	HSM115D-09	4.8	—
73 - 74	HSM115D-25	2.6	—
	HSM115D-20	2.9	—
	HSM115D-14	3.7	—
	HSM115D-09	4.8	—
75 - 76	HSM115D-25	2.7	—
	HSM115D-20	2.9	—
	HSM115D-14	3.8	—
	HSM115D-09	4.9	—
77 - 79	HSM115D-25	2.7	—
	HSM115D-20	3.0	—
	HSM115D-14	3.8	—
	HSM115D-09	4.9	—
80 - 83	HSM115D-25	2.8	—
	HSM115D-20	3.0	—
	HSM115D-14	3.9	—
	HSM115D-09	5.0	—
84	HSM115D-25	2.8	—
	HSM115D-20	3.1	—
	HSM115D-14	3.9	—
	HSM115D-09	5.1	—
85 - 86	HSM115D-25	2.8	—
	HSM115D-20	3.1	—
	HSM115D-14	3.9	—
	HSM115D-09	5.2	—
87 - 92	HSM115D-20	3.1	—
	HSM115D-14	4.0	—
	HSM115D-09	5.2	—
93 - 96	HSM115D-20	3.2	—
	HSM115D-14	4.0	—
	HSM115D-09	5.3	—
97 - 99	HSM115D-20	3.1	—
	HSM115D-14	4.0	—
	HSM115D-09	5.2	—
100	HSM115D-14	3.9	—
	HSM115D-09	5.1	—
	HSM115D-05	7.6	—
101 - 111	HSM115D-09	5.1	—

OUTPUT RPM	GEARBOX SIZE†	MIN INPUT SHAFT SHEAVE P.D. (in.)	COOLING METHOD
5 HP Motor (cont.)			
101 - 111	HSM115D-05	7.5	—
112 - 124	HSM115D-09	5.1	—
	HSM115D-05	7.3	—
125 - 127	HSM115D-09	4.9	—
	HSM115D-05	7.2	—
128 - 220	HSM107C-09	3.6	—
	HSM107C-05	5.3	—
221 - 328	HSM107C-05	5.2	—
329 - 400	HSM107C-05	5.4	—
7 1/2 HP Motor			
10	HSM407S-25	2.8	—
	HSM407S-20	3.5	—
	HSM407S-14	5.3	—
11 - 12	HSM315J-25	2.8	—
	HSM315J-20	3.5	—
	HSM315J-14	5.2	—
13	HSM315J-25	2.9	—
	HSM315J-20	3.5	—
	HSM315J-14	5.3	—
14 - 15	HSM315J-25	2.9	—
	HSM315J-20	3.6	—
	HSM315J-14	5.4	—
16	HSM307H-25	2.1	—
	HSM307H-20	2.5	—
	HSM307H-14	3.8	—
17 - 21	HSM307H-25	2.1	—
	HSM307H-20	2.6	—
	HSM307H-14	3.9	—
22	HSM215G-25	2.5	—
	HSM215G-20	3.0	—
	HSM215G-14	4.6	—
23	HSM215G-25	2.6	—
	HSM215G-20	3.0	—
	HSM215G-14	4.6	—
24	HSM215G-25	2.6	—
	HSM215G-20	3.0	—
	HSM215G-14	4.7	—
25 - 26	HSM215G-25	2.7	—
	HSM215G-20	3.1	—
	HSM215G-14	4.7	—
27 - 29	HSM215G-25	2.7	—
	HSM215G-20	3.2	—
	HSM215G-14	4.7	—
30 - 32	HSM215G-25	2.9	—
	HSM215G-20	3.3	—
	HSM215G-14	4.7	—
33	HSM215G-25	2.9	—
	HSM215G-20	3.3	—
	HSM215G-14	4.6	—
34	HSM215G-25	2.9	—
	HSM215G-20	3.4	—
	HSM215G-14	4.6	—
35 - 37	HSM215G-25	3.0	—
	HSM215G-20	3.4	—
	HSM215G-14	4.6	—
38	HSM215G-25	3.0	—
	HSM215G-20	3.5	—
	HSM215G-14	4.6	—
39 - 44	HSM207F-25	2.1	—
	HSM207F-20	2.4	—

NOTE: †Consult factory for delivery of units with 9:1 and 20:1 ratios.

HSM Speed Reducer Selection (SF = 1.4) CLASS II

OUTPUT RPM	GEARBOX SIZE†	MIN INPUT SHAFT SHEAVE P.D. (in.)	COOLING METHOD
7 1/2 HP Motor (cont.)			
39 - 44	HSM207F-14	3.2	—
45 - 50	HSM207F-25	2.1	—
	HSM207F-20	2.5	—
	HSM207F-14	3.2	—
51 - 64	HSM207F-25	2.2	—
	HSM207F-20	2.5	—
	HSM207F-14	3.2	—
65 - 66	HSM203E-25	2.9	—
	HSM203E-20	3.3	—
	HSM203E-14	4.2	—
	HSM203E-09	5.4	—
67 - 71	HSM203E-25	3.0	—
	HSM203E-20	3.3	—
	HSM203E-14	4.3	—
	HSM203E-09	5.4	—
72	HSM203E-25	3.1	—
	HSM203E-20	3.4	—
	HSM203E-14	4.3	—
	HSM203E-09	5.5	—
73	HSM203E-25	3.1	—
	HSM203E-20	3.4	—
	HSM203E-14	4.4	—
	HSM203E-09	5.5	—
74	HSM203E-25	3.2	—
	HSM203E-20	3.4	—
	HSM203E-14	4.4	—
	HSM203E-09	5.6	—
75 - 76	HSM203E-25	3.2	—
	HSM203E-20	3.5	—
	HSM203E-14	4.4	—
	HSM203E-09	5.6	—
77	HSM203E-25	3.3	—
	HSM203E-20	3.5	—
	HSM203E-14	4.5	—
	HSM203E-09	5.7	—
78	HSM203E-25	3.3	—
	HSM203E-20	3.6	—
	HSM203E-14	4.5	—
	HSM203E-09	5.7	—
79 - 80	HSM203E-25	3.4	—
	HSM203E-20	3.6	—
	HSM203E-14	4.5	—
	HSM203E-09	5.7	—
81	HSM203E-20	3.6	—
	HSM203E-14	4.6	—
	HSM203E-09	5.8	—
82 - 83	HSM203E-20	3.7	—
	HSM203E-14	4.6	—
	HSM203E-09	5.8	—
84 - 85	HSM203E-20	3.7	—
	HSM203E-14	4.6	—
	HSM203E-09	5.9	—
86 - 89	HSM203E-20	3.8	—
	HSM203E-14	4.7	—
	HSM203E-09	5.9	—
90 - 93	HSM203E-20	3.9	—
	HSM203E-14	4.7	—
	HSM203E-09	6.0	—
94 - 99	HSM203E-20	4.0	—
	HSM203E-14	4.8	—

OUTPUT RPM	GEARBOX SIZE†	MIN INPUT SHAFT SHEAVE P.D. (in.)	COOLING METHOD
7 1/2 HP Motor (cont.)			
94 - 99	HSM203E-09	6.0	—
100	HSM203E-14	4.7	—
	HSM203E-09	6.0	—
	HSM203E-05	8.7	—
101 - 109	HSM203E-09	6.0	—
	HSM203E-05	8.7	—
110 - 117	HSM203E-09	5.9	—
	HSM203E-05	8.5	—
118 - 142	HSM115D-09	5.0	—
	HSM115D-05	7.3	—
143 - 147	HSM115D-09	4.9	—
	HSM115D-05	7.1	—
148 - 152	HSM115D-09	4.9	—
	HSM115D-05	7.2	—
153 - 220	HSM115D-09	4.9	—
	HSM115D-05	7.1	—
221 - 248	HSM115D-05	7.1	—
249 - 328	HSM107C-05	5.2	—
329 - 400	HSM107C-05	5.4	—
10 HP Motor			
10	HSM415K-25	3.7	—
	HSM415K-20	4.4	—
	HSM415K-14	6.6	—
11	HSM407S-25	2.9	—
	HSM407S-20	3.5	—
	HSM407S-14	5.3	—
12 - 13	HSM407S-25	2.9	—
	HSM407S-20	3.6	—
	HSM407S-14	5.4	—
14 - 18	HSM315J-25	2.9	—
	HSM315J-20	3.6	—
	HSM315J-14	5.4	—
19	HSM315J-25	3.0	—
	HSM315J-20	3.6	—
	HSM315J-14	5.5	—
20	HSM315J-25	3.0	—
	HSM315J-20	3.7	—
	HSM315J-14	5.5	—
21	HSM307H-25	2.1	—
	HSM307H-20	2.6	—
	HSM307H-14	3.9	—
22 - 25	HSM307H-25	2.2	—
	HSM307H-20	2.6	—
	HSM307H-14	3.9	—
26	HSM307H-25	2.3	—
	HSM307H-20	2.7	—
	HSM307H-14	4.0	—
27 - 28	HSM307H-25	2.4	—
	HSM307H-20	2.7	—
	HSM307H-14	4.0	—
29	HSM215G-25	2.8	—
	HSM215G-20	3.2	—
	HSM215G-14	4.7	—
30 - 32	HSM215G-25	2.9	—
	HSM215G-20	3.3	—
	HSM215G-14	4.7	—
33	HSM215G-25	2.9	—
	HSM215G-20	3.3	—
	HSM215G-14	4.6	—
34	HSM215G-25	2.9	—

OUTPUT RPM	GEARBOX SIZE†	MIN INPUT SHAFT SHEAVE P.D. (in.)	COOLING METHOD
10 HP Motor (cont.)			
34	HSM215G-20	3.4	—
	HSM215G-14	4.6	—
35 - 37	HSM215G-25	3.0	—
	HSM215G-20	3.4	—
	HSM215G-14	4.6	—
38 - 39	HSM215G-25	3.0	—
	HSM215G-20	3.5	—
	HSM215G-14	4.6	—
40 - 53	HSM215G-25	3.1	—
	HSM215G-20	3.5	—
	HSM215G-14	4.6	—
54 - 57	HSM215G-25	3.1	—
	HSM215G-20	3.5	—
	HSM215G-14	4.7	—
58 - 69	HSM207F-25	2.2	—
	HSM207F-20	2.5	—
	HSM207F-14	3.2	—
70 - 71	HSM207F-25	2.2	—
	HSM207F-20	2.6	—
	HSM207F-14	3.3	—
72 - 74	HSM207F-25	2.3	—
	HSM207F-20	2.6	—
	HSM207F-14	3.4	—
75	HSM207F-25	2.3	—
	HSM207F-20	2.7	—
	HSM207F-14	3.4	—
76	HSM207F-25	2.3	—
	HSM207F-20	2.7	—
	HSM207F-14	3.5	—
77 - 80	HSM207F-25	2.4	—
	HSM207F-20	2.7	—
	HSM207F-14	3.5	—
81 - 86	HSM207F-20	2.8	—
	HSM207F-14	3.6	—
87 - 89	HSM203E-20	3.8	—
	HSM203E-14	4.7	—
90 - 93	HSM203E-20	3.9	—
	HSM203E-14	4.7	—
	HSM203E-09	6.0	—
94 - 99	HSM203E-20	4.0	—
	HSM203E-14	4.8	—
	HSM203E-09	6.0	—
100	HSM203E-14	4.7	—
	HSM203E-09	6.0	—
	HSM203E-05	8.7	—
101 - 109	HSM203E-09	6.0	—
	HSM203E-05	8.7	—
110 - 121	HSM203E-09	5.9	—
	HSM203E-05	8.5	—
122 - 165	HSM203E-09	5.8	—
	HSM203E-05	8.4	—
166 - 192	HSM203E-09	5.8	—
	HSM203E-05	8.2	—
193 - 194	HSM203E-09	5.7	—
	HSM203E-05	8.3	—
195	HSM203E-09	5.7	—
	HSM115D-05	7.1	—
196 - 220	HSM115D-09	4.9	—
	HSM115D-05	7.1	—
221 - 275	HSM115D-05	7.1	—

NOTE: †Consult factory for delivery of units with 9:1 and 20:1 ratios.

CLASS II HSM Speed Reducer Selection (SF = 1.4)

OUTPUT RPM	GEARBOX SIZE†	MIN INPUT SHAFT SHEAVE P.D. (in.)	COOLING METHOD
10 HP Motor (cont.)			
276 - 343	HSM115D-05	7.2	—
344 - 369	HSM115D-05	7.4	—
370 - 400	HSM107C-05	5.4	—
15 HP Motor			
10 - 11	HSM507L-25	5.0	—
	HSM507L-20	6.3	—
	HSM507L-14	9.3	—
12	HSM415K-25	3.8	—
	HSM415K-20	4.5	—
	HSM415K-14	6.8	—
13	HSM415K-25	3.8	—
	HSM415K-20	4.5	—
	HSM415K-14	6.9	—
14	HSM415K-25	3.9	—
	HSM415K-20	4.6	—
	HSM415K-14	6.9	—
15	HSM407S-25	3.0	—
	HSM407S-20	3.6	—
	HSM407S-14	5.5	—
16 - 19	HSM407S-25	3.0	—
	HSM407S-20	3.7	—
	HSM407S-14	5.5	—
20 - 21	HSM315J-25	3.0	—
	HSM315J-20	3.7	—
	HSM315J-14	5.5	—
22 - 23	HSM315J-25	3.1	—
	HSM315J-20	3.7	—
	HSM315J-14	5.5	—
24 - 27	HSM315J-25	3.2	—
	HSM315J-20	3.7	—
	HSM315J-14	5.6	—
28	HSM315J-25	3.4	—
	HSM315J-20	3.9	—
	HSM315J-14	5.6	—
29	HSM315J-25	3.5	—
	HSM315J-20	3.9	—
	HSM315J-14	5.6	—
30 - 31	HSM307H-25	2.5	—
	HSM307H-20	2.8	—
	HSM307H-14	4.0	—
32	HSM307H-25	2.5	—
	HSM307H-20	2.8	—
	HSM307H-14	3.9	—
33 - 36	HSM307H-25	2.5	—
	HSM307H-20	2.9	—
	HSM307H-14	3.9	—
37	HSM307H-25	2.6	—
	HSM307H-20	2.9	—
	HSM307H-14	3.9	—
38 - 46	HSM307H-25	2.6	—
	HSM307H-20	3.0	—
	HSM307H-14	3.9	—
47 - 53	HSM215G-25	3.1	—
	HSM215G-20	3.5	—
	HSM215G-14	4.6	—
54 - 57	HSM215G-25	3.1	—
	HSM215G-20	3.5	—
	HSM215G-14	4.7	—
58 - 60	HSM215G-25	3.1	—
	HSM215G-20	3.6	—

OUTPUT RPM	GEARBOX SIZE†	MIN INPUT SHAFT SHEAVE P.D. (in.)	COOLING METHOD
15 HP Motor (cont.)			
58 - 60	HSM215G-14	4.7	—
61 - 70	HSM215G-25	3.2	—
	HSM215G-20	3.6	—
	HSM215G-14	4.7	—
71	HSM215G-25	3.2	—
	HSM215G-20	3.7	—
	HSM215G-14	4.8	—
72 - 75	HSM215G-25	3.2	—
	HSM215G-20	3.7	—
	HSM215G-14	4.9	—
76	HSM215G-25	3.4	—
	HSM215G-20	3.8	—
	HSM215G-14	5.0	—
77 - 79	HSM215G-25	3.4	—
	HSM215G-20	3.9	—
	HSM215G-14	5.0	—
80	HSM215G-25	3.5	—
	HSM215G-20	3.9	—
	HSM215G-14	5.1	—
81	HSM215G-20	3.9	—
	HSM215G-14	5.1	—
82	HSM215G-20	4.0	—
	HSM215G-14	5.1	—
83 - 85	HSM215G-20	4.0	—
	HSM215G-14	5.2	—
86 - 88	HSM215G-14	5.2	—
89	HSM207F-20	2.8	—
	HSM207F-14	3.6	—
90 - 91	HSM207F-20	2.8	—
	HSM207F-14	3.7	—
92 - 97	HSM207F-20	2.9	—
	HSM207F-14	3.7	—
98 - 99	HSM207F-20	2.8	—
	HSM207F-14	3.6	—
100	HSM207F-14	3.6	—
	HSM207F-05	6.8	—
101 - 113	HSM207F-05	6.8	—
114 - 156	HSM207F-05	6.6	—
157 - 181	HSM207F-05	6.4	—
182 - 192	HSM203E-09	5.7	—
	HSM203E-05	8.2	—
193 - 204	HSM203E-09	5.7	—
	HSM203E-05	8.3	—
205 - 220	HSM203E-09	5.7	—
	HSM203E-05	8.2	—
221 - 244	HSM203E-05	8.2	—
245 - 292	HSM203E-05	8.3	—
293 - 349	HSM203E-05	8.5	—
350 - 398	HSM115D-05	7.4	—
399 - 400	HSM115D-05	7.6	—
20 HP Motor (cont.)			
10 - 14	HSM507L-25	5.0	—
	HSM507L-20	6.3	—
	HSM507L-14	9.3	—
15 - 18	HSM415K-25	3.9	—
	HSM415K-20	4.6	—
	HSM415K-14	6.9	—
19	HSM415K-25	4.0	—
	HSM415K-20	4.7	—
	HSM415K-14	7.1	—

OUTPUT RPM	GEARBOX SIZE†	MIN INPUT SHAFT SHEAVE P.D. (in.)	COOLING METHOD
20 HP Motor (cont.)			
20	HSM407S-25	3.0	—
	HSM407S-20	3.7	—
	HSM407S-14	5.6	—
21 - 22	HSM407S-25	3.1	—
	HSM407S-20	3.7	—
	HSM407S-14	5.6	—
23 - 25	HSM407S-25	3.2	—
	HSM407S-20	3.8	—
	HSM407S-14	5.7	—
26 - 27	HSM315J-25	3.3	—
	HSM315J-20	3.8	—
	HSM315J-14	5.6	—
28	HSM315J-25	3.4	—
	HSM315J-20	3.9	—
	HSM315J-14	5.6	—
29	HSM315J-25	3.5	—
	HSM315J-20	3.9	—
	HSM315J-14	5.6	—
30 - 31	HSM315J-25	3.5	—
	HSM315J-20	4.0	—
	HSM315J-14	5.6	—
32 - 35	HSM315J-25	3.6	—
	HSM315J-20	4.0	—
	HSM315J-14	5.6	—
36	HSM315J-25	3.6	—
	HSM315J-20	4.2	—
	HSM315J-14	5.5	—
37 - 41	HSM315J-25	3.7	—
	HSM315J-20	4.2	—
	HSM315J-14	5.4	—
42 - 54	HSM307H-25	2.6	—
	HSM307H-20	3.0	—
	HSM307H-14	3.9	—
55 - 57	HSM307H-25	2.6	—
	HSM307H-20	3.0	—
	HSM307H-14	4.0	—
58 - 63	HSM307H-25	2.7	—
	HSM307H-20	3.0	—
	HSM307H-14	4.0	—
64 - 69	HSM307H-25	2.7	—
	HSM307H-20	3.1	—
	HSM307H-14	4.0	—
70	HSM215G-25	3.2	—
	HSM215G-20	3.6	—
	HSM215G-14	4.8	—
71	HSM215G-25	3.2	—
	HSM215G-20	3.7	—
	HSM215G-14	4.8	—
72 - 75	HSM215G-25	3.2	—
	HSM215G-20	3.7	—
	HSM215G-14	4.9	—
76	HSM215G-25	3.4	—
	HSM215G-20	3.8	—
	HSM215G-14	5.0	—
77 - 79	HSM215G-25	3.4	—
	HSM215G-20	3.9	—
	HSM215G-14	5.0	—
80	HSM215G-25	3.5	—
	HSM215G-20	3.9	—
	HSM215G-14	5.1	—

NOTE: †Consult factory for delivery of units with 9:1 and 20:1 ratios.

HSM Speed Reducer Selection (SF = 1.4) CLASS II

OUTPUT RPM	GEARBOX SIZE†	MIN INPUT SHAFT SHEAVE P.D. (in.)	COOLING METHOD
20 HP Motor (cont.)			
81	HSM215G-20	3.9	—
	HSM215G-14	5.1	—
82	HSM215G-20	4.0	—
	HSM215G-14	5.1	—
83 - 85	HSM215G-20	4.0	—
	HSM215G-14	5.2	—
86 - 94	HSM215G-14	5.2	—
95	HSM215G-14	5.4	—
96 - 99	HSM215G-14	5.3	—
100	HSM215G-14	5.2	—
	HSM215G-05	9.8	—
101 - 110	HSM215G-05	9.7	—
111 - 126	HSM215G-05	9.5	—
127 - 152	HSM215G-05	9.3	—
153 - 154	HSM215G-05	9.2	—
155 - 279	HSM207F-05	6.5	—
280 - 332	HSM203E-05	8.4	—
333 - 382	HSM203E-05	8.6	—
383 - 400	HSM203E-05	8.8	—
25 HP Motor			
10	HSM608M-25	10.0	—
	HSM608M-20	11.5	—
	HSM608M-14	17.5	—
11 - 14	HSM507L-25	5.0	—
	HSM507L-20	6.3	—
	HSM507L-14	9.3	—
16 - 18	HSM507L-25	5.0	—
	HSM507L-20	6.3	—
	HSM507L-14	9.0	—
19 - 23	HSM415K-25	4.0	—
	HSM415K-20	4.7	—
	HSM415K-14	7.1	—
24 - 26	HSM407S-25	3.2	—
	HSM407S-20	3.8	—
	HSM407S-14	5.7	—
27	HSM407S-25	3.4	—
	HSM407S-20	3.9	—
	HSM407S-14	5.7	—
28	HSM407S-25	3.5	—
	HSM407S-20	3.9	—
	HSM407S-14	5.7	—
29	HSM407S-25	3.5	—
	HSM407S-20	4.0	—
	HSM407S-14	5.7	—
30 - 32	HSM407S-25	3.6	—
	HSM407S-20	4.0	—
	HSM407S-14	5.7	—
33 - 35	HSM315J-25	3.6	—
	HSM315J-20	4.1	—
	HSM315J-14	5.5	—
36	HSM315J-25	3.6	—
	HSM315J-20	4.2	—
	HSM315J-14	5.5	—
37 - 49	HSM315J-25	3.7	—
	HSM315J-20	4.2	—
	HSM315J-14	5.4	—
50 - 57	HSM315J-25	3.8	—
	HSM315J-20	4.3	—
	HSM315J-14	5.6	—
58 - 63	HSM307H-25	2.7	—

OUTPUT RPM	GEARBOX SIZE†	MIN INPUT SHAFT SHEAVE P.D. (in.)	COOLING METHOD
25 HP Motor (cont.)			
58 - 63	HSM307H-20	3.0	—
	HSM307H-14	4.0	—
64 - 71	HSM307H-25	2.7	—
	HSM307H-20	3.1	—
	HSM307H-14	4.0	—
72 - 73	HSM307H-25	2.8	—
	HSM307H-20	3.2	—
	HSM307H-14	4.1	—
74 - 76	HSM307H-25	2.8	—
	HSM307H-20	3.2	—
	HSM307H-14	4.2	—
77 - 80	HSM307H-25	2.9	—
	HSM307H-20	3.3	—
	HSM307H-14	4.2	—
81 - 82	HSM307H-14	4.3	—
83 - 85	HSM307H-14	4.4	—
86 - 94	HSM215G-14	5.2	—
95	HSM215G-14	5.4	—
96 - 99	HSM215G-14	5.3	—
100	HSM215G-14	5.2	—
	HSM215G-05	9.8	—
101 - 110	HSM215G-05	9.7	—
111 - 126	HSM215G-05	9.5	—
127 - 152	HSM215G-05	9.3	—
153 - 221	HSM215G-05	9.2	—
222 - 308	HSM207F-05	6.4	—
309 - 358	HSM207F-05	6.6	—
359 - 377	HSM207F-05	6.7	—
378 - 382	HSM203E-05	8.7	—
383 - 400	HSM203E-05	8.8	—
30 HP Motor			
10 - 11	HSM608M-25	10.0	—
	HSM608M-20	11.5	—
	HSM608M-14	17.5	—
12	HSM608M-25	10.0	—
	HSM608M-20	11.5	—
	HSM608M-14	17.3	—
13 - 15	HSM507L-25	5.0	—
	HSM507L-20	6.3	—
	HSM507L-14	9.3	—
16 - 21	HSM507L-25	5.0	—
	HSM507L-20	6.3	—
	HSM507L-14	9.0	—
22 - 23	HSM415K-25	4.0	—
	HSM415K-20	4.7	—
	HSM415K-14	7.1	—
24 - 26	HSM415K-25	4.2	—
	HSM415K-20	4.7	—
	HSM415K-14	7.2	—
27 - 28	HSM415K-25	4.4	—
	HSM415K-20	4.9	—
	HSM415K-14	7.2	—
29	HSM407S-25	3.5	—
	HSM407S-20	4.0	—
	HSM407S-14	5.7	—
30 - 32	HSM407S-25	3.6	—
	HSM407S-20	4.0	—
	HSM407S-14	5.7	—
33	HSM407S-25	3.6	—
	HSM407S-20	4.1	—

OUTPUT RPM	GEARBOX SIZE†	MIN INPUT SHAFT SHEAVE P.D. (in.)	COOLING METHOD
30 HP Motor (cont.)			
33	HSM407S-14	5.6	—
34	HSM407S-25	3.6	—
	HSM407S-20	4.2	—
	HSM407S-14	5.6	—
35 - 40	HSM407S-25	3.7	—
	HSM407S-20	4.2	—
	HSM407S-14	5.6	—
41 - 57	HSM315J-25	3.7	—
	HSM315J-20	4.3	—
	HSM315J-14	5.5	—
58	HSM315J-25	3.9	—
	HSM315J-20	4.3	—
	HSM315J-14	5.7	—
59 - 70	HSM315J-25	3.9	—
	HSM315J-20	4.4	—
	HSM315J-14	5.7	—
71	HSM315J-25	4.0	—
	HSM315J-20	4.5	—
	HSM315J-14	5.8	—
72	HSM315J-25	4.0	—
	HSM315J-20	4.6	—
	HSM315J-14	5.9	—
73	HSM307H-25	2.8	—
	HSM307H-20	3.2	—
	HSM307H-14	4.1	—
74 - 76	HSM307H-25	2.8	—
	HSM307H-20	3.2	—
	HSM307H-14	4.2	—
77 - 80	HSM307H-25	2.9	—
	HSM307H-20	3.3	—
	HSM307H-14	4.2	—
81 - 82	HSM307H-14	4.3	—
83 - 99	HSM307H-14	4.4	—
100	HSM307H-14	4.4	—
	HSM307H-05	8.4	—
101 - 106	HSM307H-05	8.4	—
107 - 118	HSM307H-05	8.2	—
119 - 152	HSM215G-05	9.4	—
153 - 278	HSM215G-05	9.2	—
279 - 288	HSM215G-05	9.3	—
289 - 358	HSM207F-05	6.5	—
359 - 400	HSM207F-05	6.7	—
40 HP Motor			
10 - 11	HSM608M-25	10.0	—
	HSM608M-20	11.5	—
	HSM608M-14	17.5	—
12 - 13	HSM608M-25	10.0	—
	HSM608M-20	11.5	—
	HSM608M-14	17.3	—
14 - 15	HSM608M-25	9.8	—
	HSM608M-20	11.5	—
	HSM608M-14	17.3	—
16	HSM608M-25	9.8	—
	HSM608M-20	11.5	—
	HSM608M-14	17.0	—
17 - 21	HSM507L-25	5.0	—
	HSM507L-20	6.3	—
	HSM507L-14	9.0	—
22 - 24	HSM507L-25	5.0	—
	HSM507L-20	6.0	—

NOTE: †Consult factory for delivery of units with 9:1 and 20:1 ratios.

CLASS II HSM Speed Reducer Selection (SF = 1.4)

OUTPUT RPM	GEARBOX SIZE†	MIN INPUT SHAFT SHEAVE P.D. (in.)	COOLING METHOD
40 HP Motor (cont.)			
22 - 24	HSM507L-14	9.0	—
25 - 26	HSM507L-25	5.3	—
	HSM507L-20	6.0	—
	HSM507L-14	9.0	—
27 - 28	HSM507L-25	5.3	—
	HSM507L-20	6.3	—
	HSM507L-14	8.8	—
29 - 32	HSM415K-25	4.5	—
	HSM415K-20	5.0	—
	HSM415K-14	7.2	—
33	HSM415K-25	4.7	—
	HSM415K-20	5.1	—
	HSM415K-14	7.1	—
34 - 38	HSM415K-25	4.7	—
	HSM415K-20	5.2	—
	HSM415K-14	7.1	—
39	HSM415K-25	4.8	—
	HSM415K-20	5.4	—
	HSM415K-14	7.0	—
40 - 47	HSM407S-25	3.8	—
	HSM407S-20	4.3	—
	HSM407S-14	5.6	—
48 - 50	HSM407S-25	3.8	—
	HSM407S-20	4.4	—
	HSM407S-14	5.6	—
51 - 57	HSM407S-25	3.8	—
	HSM407S-20	4.4	—
	HSM407S-14	5.7	—
58 - 60	HSM407S-25	3.9	—
	HSM407S-20	4.4	—
	HSM407S-14	5.7	—
61 - 70	HSM315J-25	3.9	—
	HSM315J-20	4.4	—
	HSM315J-14	5.7	—
71	HSM315J-25	4.0	—
	HSM315J-20	4.5	—
	HSM315J-14	5.8	—
72 - 74	HSM315J-25	4.0	—
	HSM315J-20	4.6	—
	HSM315J-14	5.9	—
75 - 76	HSM407S-25	4.1	—
	HSM407S-20	4.7	—
	HSM315J-14	6.0	—
77 - 78	HSM407S-25	4.2	—
	HSM407S-20	4.7	—
	HSM315J-14	6.1	—
79 - 87	HSM315J-14	6.2	—
88 - 99	HSM315J-14	6.4	—
100	HSM315J-14	6.4	—
	HSM315J-05	11.8	—
101 - 102	HSM315J-05	11.8	—
103 - 106	HSM307H-05	8.3	—
107 - 120	HSM307H-05	8.2	—
121 - 162	HSM307H-05	8.0	—
163 - 196	HSM307H-05	7.8	—
197 - 278	HSM215G-05	9.2	—
279 - 340	HSM215G-05	9.3	—
341 - 387	HSM215G-05	9.5	—
388 - 400	HSM215G-05	9.7	—

OUTPUT RPM	GEARBOX SIZE†	MIN INPUT SHAFT SHEAVE P.D. (in.)	COOLING METHOD
50 HP Motor			
12 - 13	HSM608M-25	10.0	—
	HSM608M-20	11.5	—
	HSM608M-14	17.3	—
14 - 15	HSM608M-25	9.8	—
	HSM608M-20	11.5	—
	HSM608M-14	17.3	—
16 - 17	HSM608M-25	9.8	—
	HSM608M-20	11.5	—
	HSM608M-14	17.0	—
18 - 19	HSM608M-25	9.8	—
	HSM608M-20	11.3	—
	HSM608M-14	17.0	—
20	HSM608M-25	9.8	—
	HSM608M-20	11.3	—
	HSM608M-14	16.8	—
21	HSM507L-25	5.0	—
	HSM507L-20	6.3	—
	HSM507L-14	9.0	—
22 - 24	HSM507L-25	5.0	—
	HSM507L-20	6.0	—
	HSM507L-14	9.0	—
25 - 26	HSM507L-25	5.3	—
	HSM507L-20	6.0	—
	HSM507L-14	9.0	—
27 - 30	HSM507L-25	5.3	—
	HSM507L-20	6.3	—
	HSM507L-14	8.8	—
31 - 32	HSM507L-25	5.5	—
	HSM507L-20	6.3	—
	HSM507L-14	8.8	—
33 - 34	HSM507L-25	5.5	—
	HSM507L-20	6.5	—
	HSM507L-14	8.8	—
35 - 37	HSM507L-25	5.8	—
	HSM507L-20	6.5	—
	HSM507L-14	8.8	—
38	HSM415K-25	4.8	—
	HSM415K-20	5.3	—
	HSM415K-14	7.0	—
39 - 41	HSM415K-25	4.8	—
	HSM415K-20	5.4	—
	HSM415K-14	7.0	—
42 - 44	HSM415K-25	4.9	—
	HSM415K-20	5.4	—
	HSM415K-14	7.0	—
45 - 50	HSM415K-25	4.8	—
	HSM415K-20	5.4	—
	HSM415K-14	7.0	—
51 - 54	HSM415K-25	4.9	—
	HSM415K-20	5.4	—
	HSM415K-14	7.1	—
55 - 57	HSM407S-25	3.8	—
	HSM407S-20	4.4	—
	HSM407S-14	5.7	—
58 - 70	HSM407S-25	3.9	—
	HSM407S-20	4.4	—
	HSM407S-14	5.7	—
71 - 73	HSM407S-25	4.0	—
	HSM407S-20	4.5	—
	HSM407S-14	5.9	—

OUTPUT RPM	GEARBOX SIZE†	MIN INPUT SHAFT SHEAVE P.D. (in.)	COOLING METHOD
50 HP Motor (cont.)			
74 - 76	HSM407S-25	4.1	—
	HSM407S-20	4.7	—
	HSM407S-14	6.0	—
77	HSM407S-25	4.2	—
	HSM407S-20	4.7	—
	HSM407S-14	6.1	—
78	HSM407S-25	4.2	—
	HSM407S-20	4.8	—
	HSM315J-14	6.1	—
79 - 87	HSM315J-14	6.2	—
88 - 99	HSM315J-14	6.4	—
100	HSM315J-14	6.4	—
	HSM315J-05	11.8	—
101 - 102	HSM315J-05	11.8	—
103 - 111	HSM315J-05	11.7	—
112 - 126	HSM315J-05	11.5	—
127 - 154	HSM315J-05	11.3	—
155 - 156	HSM315J-05	11.2	—
157 - 162	HSM307H-05	7.9	—
163 - 274	HSM307H-05	7.8	—
275 - 278	HSM215G-05	9.2	—
279 - 340	HSM215G-05	9.3	—
341 - 387	HSM215G-05	9.5	—
388 - 400	HSM215G-05	9.7	—
60 HP Motor			
14 - 15	HSM608M-25	9.8	—
	HSM608M-20	11.5	—
	HSM608M-14	17.3	—
16 - 17	HSM608M-25	9.8	—
	HSM608M-20	11.5	—
	HSM608M-14	17.0	—
18 - 19	HSM608M-25	9.8	—
	HSM608M-20	11.3	—
	HSM608M-14	17.0	—
20 - 23	HSM608M-25	9.8	—
	HSM608M-20	11.3	—
	HSM608M-14	16.8	—
24	HSM608M-25	10.0	—
	HSM608M-20	11.0	—
	HSM608M-14	16.5	—
25 - 26	HSM507L-25	5.3	—
	HSM507L-20	6.0	—
	HSM507L-14	9.0	—
27 - 30	HSM507L-25	5.3	—
	HSM507L-20	6.3	—
	HSM507L-14	8.8	—
31 - 32	HSM507L-25	5.5	—
	HSM507L-20	6.3	—
	HSM507L-14	8.8	—
33 - 34	HSM507L-25	5.5	—
	HSM507L-20	6.5	—
	HSM507L-14	8.8	—
35 - 38	HSM507L-25	5.8	—
	HSM507L-20	6.5	—
	HSM507L-14	8.8	—
39 - 46	HSM507L-25	5.8	—
	HSM507L-20	6.8	—
	HSM507L-14	8.8	—
47	HSM507L-25	6.0	—
	HSM507L-20	7.0	—

NOTE: †Consult factory for delivery of units with 9:1 and 20:1 ratios.

HSM Speed Reducer Selection (SF = 1.4) CLASS II

OUTPUT RPM	GEARBOX SIZE†	MIN INPUT SHAFT SHEAVE P.D. (in.)	COOLING METHOD
60 HP Motor (cont.)			
47	HSM507L-14	9.0	—
48 - 50	HSM415K-25	4.8	—
	HSM415K-20	5.4	—
	HSM415K-14	7.0	—
51 - 55	HSM415K-25	4.9	—
	HSM415K-20	5.4	—
	HSM415K-14	7.1	—
56 - 68	HSM415K-25	4.9	—
	HSM415K-20	5.4	—
	HSM415K-14	7.2	—
69	HSM415K-25	5.0	—
	HSM415K-20	5.6	—
	HSM415K-14	7.3	—
70	HSM407S-25	3.9	—
	HSM407S-20	4.5	—
	HSM407S-14	5.8	—
71 - 73	HSM407S-25	4.0	—
	HSM407S-20	4.5	—
	HSM407S-14	5.9	—
74 - 76	HSM407S-25	4.1	—
	HSM407S-20	4.7	—
	HSM407S-14	6.0	—
77	HSM407S-25	4.2	—
	HSM407S-20	4.7	—
	HSM407S-14	6.1	—
78	HSM407S-25	4.2	—
	HSM407S-20	4.8	—
	HSM407S-14	6.2	—
79 - 85	HSM407S-14	6.2	—
86 - 93	HSM407S-14	6.4	—
94 - 99	HSM315J-14	6.5	—
100	HSM315J-14	6.4	—
	HSM315J-05	11.8	—
101 - 102	HSM315J-05	11.8	—
103 - 111	HSM315J-05	11.7	—
112 - 126	HSM315J-05	11.5	—
127 - 154	HSM315J-05	11.3	—
155 - 210	HSM315J-05	11.2	—
211 - 277	HSM307H-05	7.8	—
278 - 351	HSM307H-05	7.9	—
352 - 387	HSM215G-05	9.5	—
388 - 400	HSM215G-05	9.7	—
75 HP Motor			
18 - 19	HSM608M-25	9.8	—
	HSM608M-20	11.3	—
	HSM608M-14	17.0	—
20 - 23	HSM608M-25	9.8	—
	HSM608M-20	11.3	—
	HSM608M-14	16.8	—
24 - 28	HSM608M-25	10.0	—
	HSM608M-20	11.0	—
	HSM608M-14	16.5	—
29 - 30	HSM608M-25	10.3	—
	HSM608M-20	11.3	—
	HSM608M-14	16.3	—
31	HSM608M-25	10.3	—
	HSM608M-20	11.5	—
	HSM608M-14	16.3	—
32	HSM507L-25	5.5	—
	HSM507L-20	6.3	—

OUTPUT RPM	GEARBOX SIZE†	MIN INPUT SHAFT SHEAVE P.D. (in.)	COOLING METHOD
100 HP Motor (cont.)			
32	HSM507L-14	8.8	—
33 - 34	HSM507L-25	5.5	—
	HSM507L-20	6.5	—
	HSM507L-14	8.8	—
35 - 38	HSM507L-25	5.8	—
	HSM507L-20	6.5	—
	HSM507L-14	8.8	—
39 - 46	HSM507L-25	5.8	—
	HSM507L-20	6.8	—
	HSM507L-14	8.8	—
47 - 52	HSM507L-25	6.0	—
	HSM507L-20	7.0	—
	HSM507L-14	9.0	—
53 - 58	HSM507L-25	6.0	—
	HSM507L-20	7.0	—
	HSM507L-14	9.3	—
59 - 64	HSM507L-14	9.3	—
65 - 70	HSM415K-25	5.0	—
	HSM415K-20	5.5	—
	HSM415K-14	7.2	—
71	HSM415K-25	5.1	—
	HSM415K-20	5.6	—
	HSM415K-14	7.4	—
72 - 73	HSM415K-25	5.1	—
	HSM415K-20	5.7	—
	HSM415K-14	7.4	—
74	HSM415K-25	5.2	—
	HSM415K-20	5.8	—
	HSM415K-14	7.5	—
75 - 76	HSM415K-14	7.6	—
77 - 81	HSM415K-14	7.7	—
82 - 85	HSM415K-14	7.9	—
86 - 99	HSM407S-14	6.4	—
100	HSM407S-14	6.3	—
	HSM407S-05	12.1	—
101 - 107	HSM407S-05	12.0	—
108 - 112	HSM407S-05	11.8	—
113 - 125	HSM407S-05	11.7	—
126 - 149	HSM407S-05	11.5	—
150 - 154	HSM315J-05	11.3	—
155 - 257	HSM315J-05	11.2	—
258 - 289	HSM315J-05	11.3	—
290 - 291	HSM315J-05	11.5	—
292 - 356	HSM307H-05	7.9	—
357 - 400	HSM307H-05	8.1	—
24 - 28	HSM608M-25	10.0	—
	HSM608M-20	11.0	—
	HSM608M-14	16.5	—
29 - 30	HSM608M-25	10.3	—
	HSM608M-20	11.3	—
	HSM608M-14	16.3	—
31 - 32	HSM608M-25	10.3	—
	HSM608M-20	11.5	—
	HSM608M-14	16.3	—
33 - 34	HSM608M-25	10.5	—
	HSM608M-20	11.5	—
	HSM608M-14	16.0	—
35 - 37	HSM608M-25	10.8	—
	HSM608M-20	12.0	—
	HSM608M-14	16.0	—

OUTPUT RPM	GEARBOX SIZE†	MIN INPUT SHAFT SHEAVE P.D. (in.)	COOLING METHOD
100 HP Motor (cont.)			
38 - 40	HSM608M-25	10.8	—
	HSM608M-20	12.0	—
	HSM608M-14	15.8	—
41 - 42	HSM608M-25	11.0	—
	HSM608M-20	12.0	—
	HSM608M-14	15.8	—
43	HSM608M-25	11.3	—
	HSM608M-20	12.5	—
	HSM608M-14	16.0	—
44 - 46	HSM507L-25	5.8	—
	HSM507L-20	6.8	—
	HSM507L-14	8.8	—
47 - 52	HSM507L-25	6.0	—
	HSM507L-20	7.0	—
	HSM507L-14	9.0	—
53 - 58	HSM507L-25	6.0	—
	HSM507L-20	7.0	—
	HSM507L-14	9.3	—
59 - 66	HSM507L-14	9.3	—
67 - 79	HSM507L-14	9.5	—
80 - 84	HSM507L-14	8.8	—
85 - 86	HSM507L-14	7.5	—
87 - 94	HSM415K-14	8.0	—
95 - 96	HSM415K-14	8.2	—
97 - 99	HSM415K-14	8.0	—
100	HSM415K-14	7.9	—
	HSM415K-05	16.0	—
101 - 103	HSM415K-05	15.9	—
104 - 105	HSM415K-05	15.7	—
106 - 110	HSM415K-05	15.5	—
111 - 113	HSM415K-05	15.3	—
114 - 121	HSM415K-05	15.2	—
122 - 133	HSM415K-05	15.0	—
134 - 144	HSM415K-05	14.8	—
145 - 161	HSM407S-05	11.5	—
162 - 227	HSM407S-05	11.3	—
228 - 233	HSM407S-05	11.2	—
234 - 237	HSM407S-05	11.3	—
238 - 257	HSM315J-05	11.2	—
258 - 289	HSM315J-05	11.3	—
290 - 338	HSM315J-05	11.5	—
339 - 358	HSM315J-05	11.7	—
359 - 388	HSM315J-05	11.8	—
389 - 400	HSM315J-05	12.0	—
125 HP Motor			
31 - 32	HSM608M-25	10.3	—
	HSM608M-20	11.5	—
	HSM608M-14	16.3	—
33 - 34	HSM608M-25	10.5	—
	HSM608M-20	11.5	—
	HSM608M-14	16.0	—
35 - 37	HSM608M-25	10.8	—
	HSM608M-20	12.0	—
	HSM608M-14	16.0	—
38 - 40	HSM608M-25	10.8	—
	HSM608M-20	12.0	—
	HSM608M-14	15.8	—
41 - 42	HSM608M-25	11.0	—
	HSM608M-20	12.0	—
	HSM608M-14	15.8	—

NOTE: †Consult factory for delivery of units with 9:1 and 20:1 ratios.

CLASS II HSM Speed Reducer Selection (SF = 1.4)

OUTPUT RPM	GEARBOX SIZE†	MIN INPUT SHAFT SHEAVE P.D. (in.)	COOLING METHOD
125 HP Motor (cont.)			
43 - 46	HSM608M-25	11.3	—
	HSM608M-20	12.5	—
	HSM608M-14	16.0	—
47 - 50	HSM608M-25	11.3	—
	HSM608M-20	12.5	—
	HSM608M-14	16.3	—
51 - 52	HSM608M-25	11.3	—
	HSM608M-20	12.8	—
	HSM608M-14	16.5	—
53 - 54	HSM608M-25	11.5	—
	HSM608M-20	12.8	—
	HSM608M-14	16.8	—
55 - 57	HSM608M-14	17.0	—
58	HSM507L-25	6.0	—
	HSM507L-20	7.0	—
	HSM507L-14	9.3	—
59 - 66	HSM507L-14	9.3	—
67 - 79	HSM507L-14	9.5	—
80 - 84	HSM507L-14	8.8	—
85 - 89	HSM507L-14	7.5	—
90 - 94	HSM507L-14	6.5	—
95 - 100	HSM507L-14	6.0	—
132 - 145	HSM415K-05	14.9	—
146 - 209	HSM415K-05	14.7	—
210 - 227	HSM407S-05	11.3	—
228 - 233	HSM407S-05	11.2	—
234 - 284	HSM407S-05	11.3	—
285 - 325	HSM407S-05	11.5	—
326 - 358	HSM315J-05	11.6	—

OUTPUT RPM	GEARBOX SIZE†	MIN INPUT SHAFT SHEAVE P.D. (in.)	COOLING METHOD
125 HP Motor (cont.)			
359 - 374	HSM315J-05	11.8	—
375 - 400	HSM315J-05	11.9	Fan
150 HP Motor			
38 - 40	HSM608M-25	10.8	—
	HSM608M-20	12.0	—
	HSM608M-14	15.8	—
41 - 42	HSM608M-25	11.0	—
	HSM608M-20	12.0	—
	HSM608M-14	15.8	—
43 - 46	HSM608M-25	11.3	—
	HSM608M-20	12.5	—
	HSM608M-14	16.0	—
47 - 50	HSM608M-25	11.3	—
	HSM608M-20	12.5	—
	HSM608M-14	16.3	—
51 - 52	HSM608M-25	11.3	—
	HSM608M-20	12.8	—
	HSM608M-14	16.5	—
53 - 54	HSM608M-25	11.5	—
	HSM608M-20	12.8	—
	HSM608M-14	16.8	—
55 - 70	HSM608M-14	17.0	—
71	HSM608M-14	17.3	—
72 - 79	HSM507L-14	9.5	—
80 - 84	HSM507L-14	8.8	—
85 - 89	HSM507L-14	7.5	—
90 - 94	HSM507L-14	6.5	—
95 - 100	HSM507L-14	6.0	—

OUTPUT RPM	GEARBOX SIZE†	MIN INPUT SHAFT SHEAVE P.D. (in.)	COOLING METHOD
150 HP Motor (cont.)			
181 - 274	HSM415K-05	14.6	—
275 - 305	HSM407S-05	11.4	—
306 - 362	HSM407S-05	11.6	—
363 - 395	HSM407S-05	11.8	—
396 - 400	HSM407S-05	12.0	—
200 HP Motor			
54	HSM608M-25	11.5	—
	HSM608M-20	12.8	—
	HSM608M-14	16.8	—
55 - 70	HSM608M-14	17.0	—
71 - 79	HSM608M-14	17.3	—
80 - 84	HSM608M-14	15.0	—
85 - 88	HSM608M-14	12.8	—
89	HSM608M-14	12.8	Fan
90	HSM608M-14	11.0	Fan
279 - 297	HSM415K-05	14.6	—
298 - 325	HSM415K-05	14.8	—
326 - 376	HSM415K-05	15.0	—
377 - 391	HSM415K-05	15.2	—
392 - 393	HSM415K-05	15.3	—
394 - 400	HSM415K-05	15.3	Fan
250 HP Motor			
71 - 79	HSM608M-14	17.3	—
80 - 84	HSM608M-14	15.0	—
85 - 86	HSM608M-14	12.8	—
87 - 88	HSM608M-14	12.8	Fan
378 - 391	HSM415K-05	15.2	Fan
392 - 400	HSM415K-05	15.3	Fan

NOTE: †Consult factory for delivery of units with 9:1 and 20:1 ratios.

HSM Speed Reducer Selection (SF = 2.0) CLASS III

OUTPUT RPM	GEARBOX SIZE†	MIN INPUT SHAFT SHEAVE P.D. (in.)	COOLING METHOD
1/4 HP Motor			
10 - 11	HSM107C-25	1.4	—
	HSM107C-20	1.6	—
	HSM107C-14	2.4	—
	HSM107C-09	3.5	—
12 - 17	HSM107C-25	1.4	—
	HSM107C-20	1.6	—
	HSM107C-14	2.5	—
	HSM107C-09	3.5	—
18	HSM107C-25	1.5	—
	HSM107C-20	1.7	—
	HSM107C-14	2.5	—
	HSM107C-09	3.5	—
19 - 24	HSM107C-25	1.5	—
	HSM107C-20	1.7	—
	HSM107C-14	2.6	—
	HSM107C-09	3.5	—
25 - 26	HSM107C-25	1.6	—
	HSM107C-20	1.7	—
	HSM107C-14	2.6	—
	HSM107C-09	3.4	—
27 - 36	HSM107C-25	1.6	—
	HSM107C-20	1.8	—
	HSM107C-14	2.6	—
	HSM107C-09	3.4	—
37	HSM107C-25	1.8	—
	HSM107C-20	1.9	—
	HSM107C-14	2.5	—
	HSM107C-09	3.4	—
38	HSM107C-25	1.8	—
	HSM107C-20	1.9	—
	HSM107C-14	2.5	—
	HSM107C-09	3.3	—
39	HSM107C-25	1.8	—
	HSM107C-20	1.9	—
	HSM107C-14	2.6	—
	HSM107C-09	3.3	—
40 - 65	HSM107C-25	1.8	—
	HSM107C-20	2.0	—
	HSM107C-14	2.6	—
	HSM107C-09	3.3	—
66 - 68	HSM107C-25	1.9	—
	HSM107C-20	2.0	—
	HSM107C-14	2.7	—
	HSM107C-09	3.3	—
69 - 70	HSM107C-25	1.9	—
	HSM107C-20	2.0	—
	HSM107C-14	2.7	—
	HSM107C-09	3.4	—
71 - 74	HSM107C-25	1.9	—
	HSM107C-20	2.1	—
	HSM107C-14	2.7	—
	HSM107C-09	3.4	—
75	HSM107C-25	1.9	—
	HSM107C-20	2.1	—
	HSM107C-14	2.8	—
	HSM107C-09	3.5	—
76	HSM107C-25	2.0	—
	HSM107C-20	2.1	—
	HSM107C-14	2.8	—
	HSM107C-09	3.4	—

OUTPUT RPM	GEARBOX SIZE†	MIN INPUT SHAFT SHEAVE P.D. (in.)	COOLING METHOD
1/4 HP Motor (cont.)			
77 - 79	HSM107C-25	2.0	—
	HSM107C-20	2.2	—
	HSM107C-14	2.8	—
	HSM107C-09	3.4	—
80	HSM107C-25	2.0	—
	HSM107C-20	2.2	—
	HSM107C-14	2.9	—
	HSM107C-09	3.4	—
81 - 83	HSM107C-25	2.0	—
	HSM107C-20	2.2	—
	HSM107C-14	2.9	—
	HSM107C-09	3.5	—
84 - 86	HSM107C-25	2.1	—
	HSM107C-20	2.2	—
	HSM107C-14	2.9	—
	HSM107C-09	3.5	—
87 - 90	HSM107C-20	2.3	—
	HSM107C-14	2.9	—
	HSM107C-09	3.5	—
91 - 93	HSM107C-20	2.3	—
	HSM107C-14	3.0	—
	HSM107C-09	3.5	—
94 - 97	HSM107C-20	2.3	—
	HSM107C-14	3.0	—
	HSM107C-09	3.6	—
98 - 99	HSM107C-20	2.3	—
	HSM107C-14	2.9	—
	HSM107C-09	3.7	—
100	HSM107C-14	2.9	—
	HSM107C-09	3.7	—
	HSM107C-05	5.6	—
101 - 102	HSM107C-09	3.7	—
	HSM107C-05	5.5	—
103 - 116	HSM107C-09	3.6	—
	HSM107C-05	5.5	—
117 - 220	HSM107C-09	3.6	—
	HSM107C-05	5.3	—
221 - 328	HSM107C-05	5.2	—
329 - 400	HSM107C-05	5.4	—
1/3 HP Motor			
10 - 11	HSM107C-25	1.4	—
	HSM107C-20	1.6	—
	HSM107C-14	2.4	—
	HSM107C-09	3.5	—
12 - 17	HSM107C-25	1.4	—
	HSM107C-20	1.6	—
	HSM107C-14	2.5	—
	HSM107C-09	3.5	—
18	HSM107C-25	1.5	—
	HSM107C-20	1.7	—
	HSM107C-14	2.5	—
	HSM107C-09	3.5	—
19 - 24	HSM107C-25	1.5	—
	HSM107C-20	1.7	—
	HSM107C-14	2.6	—
	HSM107C-09	3.5	—
25 - 26	HSM107C-25	1.6	—
	HSM107C-20	1.7	—
	HSM107C-14	2.6	—
	HSM107C-09	3.4	—

OUTPUT RPM	GEARBOX SIZE†	MIN INPUT SHAFT SHEAVE P.D. (in.)	COOLING METHOD
1/3 HP Motor (cont.)			
27 - 36	HSM107C-25	1.6	—
	HSM107C-20	1.8	—
	HSM107C-14	2.6	—
	HSM107C-09	3.4	—
37	HSM107C-25	1.8	—
	HSM107C-20	1.9	—
	HSM107C-14	2.5	—
	HSM107C-09	3.4	—
38	HSM107C-25	1.8	—
	HSM107C-20	1.9	—
	HSM107C-14	2.5	—
	HSM107C-09	3.3	—
39	HSM107C-25	1.8	—
	HSM107C-20	1.9	—
	HSM107C-14	2.6	—
	HSM107C-09	3.3	—
40 - 65	HSM107C-25	1.8	—
	HSM107C-20	2.0	—
	HSM107C-14	2.6	—
	HSM107C-09	3.3	—
66 - 68	HSM107C-25	1.9	—
	HSM107C-20	2.0	—
	HSM107C-14	2.7	—
	HSM107C-09	3.3	—
69 - 70	HSM107C-25	1.9	—
	HSM107C-20	2.0	—
	HSM107C-14	2.7	—
	HSM107C-09	3.4	—
71 - 74	HSM107C-25	1.9	—
	HSM107C-20	2.1	—
	HSM107C-14	2.7	—
	HSM107C-09	3.4	—
75	HSM107C-25	1.9	—
	HSM107C-20	2.1	—
	HSM107C-14	2.8	—
	HSM107C-09	3.5	—
76	HSM107C-25	2.0	—
	HSM107C-20	2.1	—
	HSM107C-14	2.8	—
	HSM107C-09	3.4	—
77 - 79	HSM107C-25	2.0	—
	HSM107C-20	2.2	—
	HSM107C-14	2.8	—
	HSM107C-09	3.4	—
80	HSM107C-25	2.0	—
	HSM107C-20	2.2	—
	HSM107C-14	2.9	—
	HSM107C-09	3.4	—
81 - 83	HSM107C-25	2.0	—
	HSM107C-20	2.2	—
	HSM107C-14	2.9	—
	HSM107C-09	3.5	—
84 - 86	HSM107C-25	2.1	—
	HSM107C-20	2.2	—
	HSM107C-14	2.9	—
	HSM107C-09	3.5	—
87 - 90	HSM107C-20	2.3	—
	HSM107C-14	2.9	—
	HSM107C-09	3.5	—
91 - 93	HSM107C-20	2.3	—

NOTE: †Consult factory for delivery of units with 9:1 and 20:1 ratios.

CLASS III HSM Speed Reducer Selection (SF = 2.0)

OUTPUT RPM	GEARBOX SIZE†	MIN INPUT SHAFT SHEAVE P.D. (in.)	COOLING METHOD
1/3 HP Motor (cont.)			
91 - 93	HSM107C-14	3.0	—
	HSM107C-09	3.5	—
94 - 97	HSM107C-20	2.3	—
	HSM107C-14	3.0	—
	HSM107C-09	3.6	—
98 - 99	HSM107C-20	2.3	—
	HSM107C-14	2.9	—
	HSM107C-09	3.7	—
100	HSM107C-14	2.9	—
	HSM107C-09	3.7	—
	HSM107C-05	5.6	—
101 - 102	HSM107C-09	3.7	—
	HSM107C-05	5.5	—
103 - 116	HSM107C-09	3.6	—
	HSM107C-05	5.5	—
117 - 220	HSM107C-09	3.6	—
	HSM107C-05	5.3	—
221 - 328	HSM107C-05	5.2	—
329 - 400	HSM107C-05	5.4	—
1/2 HP Motor			
10	HSM115D-25	1.9	—
	HSM115D-20	2.1	—
	HSM115D-14	3.2	—
	HSM115D-09	4.9	—
11 - 13	HSM115D-25	1.9	—
	HSM115D-20	2.2	—
	HSM115D-14	3.3	—
	HSM115D-09	5.0	—
14 - 17	HSM107C-25	1.4	—
	HSM107C-20	1.6	—
	HSM107C-14	2.5	—
	HSM107C-09	3.5	—
18	HSM107C-25	1.5	—
	HSM107C-20	1.7	—
	HSM107C-14	2.5	—
	HSM107C-09	3.5	—
19 - 24	HSM107C-25	1.5	—
	HSM107C-20	1.7	—
	HSM107C-14	2.6	—
	HSM107C-09	3.5	—
25 - 26	HSM107C-25	1.6	—
	HSM107C-20	1.7	—
	HSM107C-14	2.6	—
	HSM107C-09	3.4	—
27 - 36	HSM107C-25	1.6	—
	HSM107C-20	1.8	—
	HSM107C-14	2.6	—
	HSM107C-09	3.4	—
37	HSM107C-25	1.8	—
	HSM107C-20	1.9	—
	HSM107C-14	2.5	—
	HSM107C-09	3.4	—
38	HSM107C-25	1.8	—
	HSM107C-20	1.9	—
	HSM107C-14	2.5	—
	HSM107C-09	3.4	—
39	HSM107C-25	1.8	—
	HSM107C-20	1.9	—
	HSM107C-14	2.6	—
	HSM107C-09	3.3	—

OUTPUT RPM	GEARBOX SIZE†	MIN INPUT SHAFT SHEAVE P.D. (in.)	COOLING METHOD
1/2 HP Motor (cont.)			
40 - 65	HSM107C-25	1.8	—
	HSM107C-20	2.0	—
	HSM107C-14	2.6	—
	HSM107C-09	3.3	—
66 - 68	HSM107C-25	1.9	—
	HSM107C-20	2.0	—
	HSM107C-14	2.7	—
	HSM107C-09	3.3	—
69 - 70	HSM107C-25	1.9	—
	HSM107C-20	2.0	—
	HSM107C-14	2.7	—
	HSM107C-09	3.4	—
71 - 74	HSM107C-25	1.9	—
	HSM107C-20	2.1	—
	HSM107C-14	2.7	—
	HSM107C-09	3.4	—
75	HSM107C-25	1.9	—
	HSM107C-20	2.1	—
	HSM107C-14	2.8	—
	HSM107C-09	3.5	—
76	HSM107C-25	2.0	—
	HSM107C-20	2.1	—
	HSM107C-14	2.8	—
	HSM107C-09	3.4	—
77 - 79	HSM107C-25	2.0	—
	HSM107C-20	2.2	—
	HSM107C-14	2.8	—
	HSM107C-09	3.4	—
80	HSM107C-25	2.0	—
	HSM107C-20	2.2	—
	HSM107C-14	2.9	—
	HSM107C-09	3.4	—
81 - 83	HSM107C-25	2.0	—
	HSM107C-20	2.2	—
	HSM107C-14	2.9	—
	HSM107C-09	3.5	—
84 - 86	HSM107C-25	2.1	—
	HSM107C-20	2.2	—
	HSM107C-14	2.9	—
	HSM107C-09	3.5	—
87 - 90	HSM107C-20	2.3	—
	HSM107C-14	2.9	—
	HSM107C-09	3.5	—
91 - 93	HSM107C-20	2.3	—
	HSM107C-14	3.0	—
	HSM107C-09	3.5	—
94 - 97	HSM107C-20	2.3	—
	HSM107C-14	3.0	—
	HSM107C-09	3.6	—
98 - 99	HSM107C-20	2.3	—
	HSM107C-14	2.9	—
	HSM107C-09	3.7	—
100	HSM107C-14	2.9	—
	HSM107C-09	3.7	—
	HSM107C-05	5.6	—
101 - 102	HSM107C-09	3.7	—
	HSM107C-05	5.5	—
103 - 116	HSM107C-09	3.6	—
	HSM107C-05	5.5	—
117 - 220	HSM107C-09	3.6	—

OUTPUT RPM	GEARBOX SIZE†	MIN INPUT SHAFT SHEAVE P.D. (in.)	COOLING METHOD
1/2 HP Motor (cont.)			
117 - 220	HSM107C-05	5.3	—
221 - 328	HSM107C-05	5.2	—
329 - 400	HSM107C-05	5.4	—
3/4 HP Motor (cont.)			
10	HSM203E-25	2.1	—
	HSM203E-20	2.5	—
	HSM203E-14	3.8	—
	HSM203E-09	5.7	—
11 - 12	HSM203E-25	2.1	—
	HSM203E-20	2.6	—
	HSM203E-14	3.9	—
	HSM203E-09	5.7	—
13 - 14	HSM115D-25	1.9	—
	HSM115D-20	2.2	—
	HSM115D-14	3.3	—
	HSM115D-09	5.0	—
15	HSM115D-25	1.9	—
	HSM115D-20	2.2	—
	HSM115D-14	3.4	—
	HSM115D-09	5.1	—
16	HSM115D-25	2.0	—
	HSM115D-20	2.3	—
	HSM115D-14	3.4	—
	HSM115D-09	5.1	—
17 - 19	HSM115D-25	2.0	—
	HSM115D-20	2.3	—
	HSM115D-14	3.4	—
	HSM115D-09	5.2	—
20 - 21	HSM107C-25	1.5	—
	HSM107C-20	1.7	—
	HSM107C-14	2.6	—
	HSM115D-09	5.2	—
22 - 24	HSM107C-25	1.5	—
	HSM107C-20	1.7	—
	HSM107C-14	2.6	—
	HSM107C-09	3.5	—
25 - 26	HSM107C-25	1.6	—
	HSM107C-20	1.7	—
	HSM107C-14	2.6	—
	HSM107C-09	3.4	—
27 - 36	HSM107C-25	1.6	—
	HSM107C-20	1.8	—
	HSM107C-14	2.6	—
	HSM107C-09	3.4	—
37	HSM107C-25	1.8	—
	HSM107C-20	1.9	—
	HSM107C-14	2.5	—
	HSM107C-09	3.4	—
38	HSM107C-25	1.8	—
	HSM107C-20	1.9	—
	HSM107C-14	2.5	—
	HSM107C-09	3.3	—
39	HSM107C-25	1.8	—
	HSM107C-20	1.9	—
	HSM107C-14	2.6	—
	HSM107C-09	3.3	—
40 - 65	HSM107C-25	1.8	—
	HSM107C-20	2.0	—
	HSM107C-14	2.6	—
	HSM107C-09	3.3	—

NOTE: †Consult factory for delivery of units with 9:1 and 20:1 ratios.

HSM Speed Reducer Selection (SF = 2.0) **CLASS III**

OUTPUT RPM	GEARBOX SIZE [†]	MIN INPUT SHAFT SHEAVE P.D. (in.)	COOLING METHOD
3/4 HP Motor (cont.)			
66 - 68	HSM107C-25	1.9	—
	HSM107C-20	2.0	—
	HSM107C-14	2.7	—
	HSM107C-09	3.3	—
69 - 70	HSM107C-25	1.9	—
	HSM107C-20	2.0	—
	HSM107C-14	2.7	—
71 - 74	HSM107C-09	3.4	—
	HSM107C-25	1.9	—
	HSM107C-20	2.1	—
75	HSM107C-14	2.7	—
	HSM107C-09	3.4	—
	HSM107C-25	1.9	—
	HSM107C-20	2.1	—
76	HSM107C-14	2.8	—
	HSM107C-09	3.5	—
	HSM107C-25	2.0	—
77 - 79	HSM107C-20	2.1	—
	HSM107C-14	2.8	—
	HSM107C-09	3.4	—
	HSM107C-25	2.0	—
80	HSM107C-20	2.2	—
	HSM107C-14	2.8	—
	HSM107C-09	3.4	—
	HSM107C-25	2.0	—
81 - 83	HSM107C-20	2.2	—
	HSM107C-14	2.9	—
	HSM107C-09	3.4	—
	HSM107C-25	2.0	—
84 - 86	HSM107C-20	2.2	—
	HSM107C-14	2.9	—
	HSM107C-09	3.5	—
	HSM107C-25	2.1	—
87 - 90	HSM107C-20	2.2	—
	HSM107C-14	2.9	—
	HSM107C-09	3.5	—
	HSM107C-25	2.3	—
91 - 93	HSM107C-14	2.9	—
	HSM107C-09	3.5	—
	HSM107C-20	2.3	—
	HSM107C-14	3.0	—
94 - 97	HSM107C-09	3.5	—
	HSM107C-20	2.3	—
	HSM107C-14	3.0	—
	HSM107C-09	3.6	—
98 - 99	HSM107C-20	2.3	—
	HSM107C-14	2.9	—
	HSM107C-09	3.7	—
100	HSM107C-09	3.7	—
	HSM107C-14	2.9	—
	HSM107C-05	5.6	—
101 - 102	HSM107C-09	3.7	—
	HSM107C-05	5.5	—
103 - 116	HSM107C-09	3.6	—
	HSM107C-05	5.5	—
	HSM107C-09	3.6	—
117 - 220	HSM107C-05	5.3	—
	HSM107C-05	5.2	—
221 - 328	HSM107C-05	5.2	—
	HSM107C-05	5.4	—
329 - 400	HSM107C-05	5.4	—

OUTPUT RPM	GEARBOX SIZE [†]	MIN INPUT SHAFT SHEAVE P.D. (in.)	COOLING METHOD
1 HP Motor			
10 - 11	HSM207F-25	1.6	—
	HSM207F-20	2.0	—
	HSM207F-14	3.0	—
12 - 14	HSM203E-25	2.1	—
	HSM203E-20	2.6	—
	HSM203E-14	3.9	—
15	HSM203E-09	5.8	—
	HSM203E-25	2.1	—
	HSM203E-20	2.6	—
16	HSM203E-14	4.0	—
	HSM203E-09	5.8	—
	HSM203E-25	2.1	—
	HSM203E-20	2.7	—
17 - 19	HSM203E-14	4.0	—
	HSM203E-09	5.8	—
	HSM115D-25	2.0	—
	HSM115D-20	2.3	—
20 - 22	HSM115D-14	3.4	—
	HSM115D-09	5.2	—
	HSM115D-25	2.0	—
	HSM115D-20	2.3	—
23 - 25	HSM115D-14	3.5	—
	HSM115D-09	5.2	—
	HSM115D-25	2.1	—
	HSM115D-20	2.3	—
26	HSM115D-14	3.5	—
	HSM115D-09	5.3	—
	HSM107C-25	1.6	—
	HSM107C-20	1.7	—
27 - 28	HSM107C-14	2.6	—
	HSM107C-09	5.3	—
	HSM107C-25	1.6	—
	HSM107C-20	1.8	—
29 - 36	HSM107C-14	2.6	—
	HSM115D-09	5.3	—
	HSM107C-25	1.7	—
	HSM107C-20	1.8	—
37	HSM107C-14	2.6	—
	HSM107C-09	3.4	—
	HSM107C-25	1.8	—
	HSM107C-20	1.9	—
38	HSM107C-14	2.5	—
	HSM107C-09	3.4	—
	HSM107C-25	1.8	—
	HSM107C-20	1.9	—
39	HSM107C-14	2.5	—
	HSM107C-09	3.3	—
	HSM107C-25	1.8	—
	HSM107C-20	1.9	—
40 - 65	HSM107C-14	2.6	—
	HSM107C-09	3.3	—
	HSM107C-25	1.8	—
	HSM107C-20	2.0	—
66 - 68	HSM107C-14	2.6	—
	HSM107C-09	3.3	—
	HSM107C-25	1.9	—
	HSM107C-20	2.0	—
69 - 70	HSM107C-14	2.7	—
	HSM107C-09	3.3	—
	HSM107C-25	1.9	—

OUTPUT RPM	GEARBOX SIZE [†]	MIN INPUT SHAFT SHEAVE P.D. (in.)	COOLING METHOD
1 HP Motor (cont.)			
69 - 70	HSM107C-20	2.0	—
	HSM107C-14	2.7	—
	HSM107C-09	3.4	—
71 - 74	HSM107C-25	1.9	—
	HSM107C-20	2.1	—
	HSM107C-14	2.7	—
75	HSM107C-09	3.4	—
	HSM107C-25	1.9	—
	HSM107C-20	2.1	—
76	HSM107C-14	2.8	—
	HSM107C-09	3.5	—
	HSM107C-25	2.0	—
	HSM107C-20	2.1	—
77 - 79	HSM107C-14	2.8	—
	HSM107C-09	3.4	—
	HSM107C-25	2.0	—
	HSM107C-20	2.2	—
80	HSM107C-14	2.8	—
	HSM107C-09	3.4	—
	HSM107C-25	2.0	—
	HSM107C-20	2.2	—
81 - 83	HSM107C-14	2.9	—
	HSM107C-09	3.4	—
	HSM107C-25	2.0	—
	HSM107C-20	2.2	—
84 - 86	HSM107C-14	2.9	—
	HSM107C-09	3.5	—
	HSM107C-25	2.1	—
	HSM107C-20	2.2	—
87 - 90	HSM107C-14	2.9	—
	HSM107C-09	3.5	—
	HSM107C-25	2.3	—
	HSM107C-20	2.3	—
91 - 93	HSM107C-14	3.0	—
	HSM107C-09	3.5	—
	HSM107C-25	2.3	—
	HSM107C-20	2.3	—
94 - 97	HSM107C-14	3.0	—
	HSM107C-09	3.6	—
	HSM107C-25	2.3	—
	HSM107C-20	2.3	—
98 - 99	HSM107C-14	2.9	—
	HSM107C-09	3.7	—
	HSM107C-25	2.3	—
	HSM107C-20	2.3	—
100	HSM107C-14	2.9	—
	HSM107C-09	3.7	—
	HSM107C-05	5.6	—
	HSM107C-09	3.7	—
101 - 102	HSM107C-09	3.7	—
	HSM107C-05	5.5	—
103 - 116	HSM107C-09	3.6	—
	HSM107C-05	5.5	—
117 - 220	HSM107C-09	3.6	—
	HSM107C-05	5.3	—
221 - 328	HSM107C-05	5.2	—
	HSM107C-05	5.4	—
329 - 400	HSM107C-05	5.4	—
	1 1/2 HP Motor		
10	HSM215G-25	2.3	—
	HSM215G-20	2.8	—
	HSM215G-14	4.3	—
11	HSM215G-25	2.3	—
	HSM215G-20	2.9	—

NOTE: [†]Consult factory for delivery of units with 9:1 and 20:1 ratios.

CLASS III HSM Speed Reducer Selection (SF = 2.0)

OUTPUT RPM	GEARBOX SIZE†	MIN INPUT SHAFT SHEAVE P.D. (in.)	COOLING METHOD
1 1/2 HP Motor (cont.)			
11	HSM215G-14	4.4	—
12	HSM207F-25	1.6	—
	HSM207F-20	2.0	—
	HSM207F-14	3.0	—
13	HSM207F-25	1.7	—
	HSM207F-20	2.0	—
	HSM207F-14	3.1	—
14 - 15	HSM207F-25	1.7	—
	HSM207F-20	2.1	—
	HSM207F-14	3.1	—
16	HSM203E-25	2.1	—
	HSM203E-20	2.7	—
	HSM203E-14	4.0	—
17 - 24	HSM203E-25	2.2	—
	HSM203E-20	2.7	—
	HSM203E-14	4.0	—
	HSM203E-09	5.8	—
25	HSM115D-25	2.1	—
	HSM115D-20	2.3	—
	HSM115D-14	3.5	—
	HSM115D-09	5.3	—
26 - 28	HSM115D-25	2.2	—
	HSM115D-20	2.4	—
	HSM115D-14	3.5	—
	HSM115D-09	5.3	—
29 - 33	HSM115D-25	2.3	—
	HSM115D-20	2.5	—
	HSM115D-14	3.5	—
	HSM115D-09	5.3	—
34	HSM115D-25	2.4	—
	HSM115D-20	2.6	—
	HSM115D-14	3.5	—
	HSM115D-09	5.2	—
35 - 38	HSM115D-25	2.4	—
	HSM115D-20	2.6	—
	HSM115D-14	3.4	—
	HSM115D-09	5.2	—
39	HSM115D-25	2.4	—
	HSM115D-20	2.7	—
	HSM115D-14	3.4	—
	HSM115D-09	5.1	—
40 - 44	HSM107C-25	1.8	—
	HSM107C-20	2.0	—
	HSM107C-14	2.6	—
	HSM115D-09	5.1	—
45 - 65	HSM107C-25	1.8	—
	HSM107C-20	2.0	—
	HSM107C-14	2.6	—
	HSM107C-09	3.3	—
66 - 68	HSM107C-25	1.9	—
	HSM107C-20	2.0	—
	HSM107C-14	2.7	—
	HSM107C-09	3.3	—
69 - 70	HSM107C-25	1.9	—
	HSM107C-20	2.0	—
	HSM107C-14	2.7	—
	HSM107C-09	3.4	—
71 - 74	HSM107C-25	1.9	—
	HSM107C-20	2.1	—
	HSM107C-14	2.7	—

OUTPUT RPM	GEARBOX SIZE†	MIN INPUT SHAFT SHEAVE P.D. (in.)	COOLING METHOD
1 1/2 HP Motor (cont.)			
71 - 74	HSM107C-09	3.4	—
75	HSM107C-25	1.9	—
	HSM107C-20	2.1	—
	HSM107C-14	2.8	—
	HSM107C-09	3.5	—
76	HSM107C-25	2.0	—
	HSM107C-20	2.1	—
	HSM107C-14	2.8	—
	HSM107C-09	3.4	—
77 - 79	HSM107C-25	2.0	—
	HSM107C-20	2.2	—
	HSM107C-14	2.8	—
	HSM107C-09	3.4	—
80	HSM107C-25	2.0	—
	HSM107C-20	2.2	—
	HSM107C-14	2.9	—
	HSM107C-09	3.4	—
81 - 83	HSM107C-25	2.0	—
	HSM107C-20	2.2	—
	HSM107C-14	2.9	—
	HSM107C-09	3.5	—
84 - 86	HSM107C-25	2.1	—
	HSM107C-20	2.2	—
	HSM107C-14	2.9	—
	HSM107C-09	3.5	—
87 - 90	HSM107C-20	2.3	—
	HSM107C-14	2.9	—
	HSM107C-09	3.5	—
91 - 93	HSM107C-20	2.3	—
	HSM107C-14	3.0	—
	HSM107C-09	3.5	—
94 - 97	HSM107C-20	2.3	—
	HSM107C-14	3.0	—
	HSM107C-09	3.6	—
98 - 99	HSM107C-20	2.3	—
	HSM107C-14	2.9	—
	HSM107C-09	3.7	—
100	HSM107C-14	2.9	—
	HSM107C-09	3.7	—
	HSM107C-05	5.6	—
101 - 102	HSM107C-09	3.7	—
	HSM107C-05	5.5	—
103 - 116	HSM107C-09	3.6	—
	HSM107C-05	5.5	—
117 - 220	HSM107C-09	3.6	—
	HSM107C-05	5.3	—
221 - 328	HSM107C-05	5.2	—
329 - 400	HSM107C-05	5.4	—
2 HP Motor			
10	HSM215G-25	2.3	—
	HSM215G-20	2.8	—
	HSM215G-14	4.3	—
11 - 12	HSM215G-25	2.3	—
	HSM215G-20	2.9	—
	HSM215G-14	4.4	—
13 - 14	HSM215G-25	2.4	—
	HSM215G-20	2.9	—
	HSM215G-14	4.5	—
15 - 17	HSM207F-25	1.7	—
	HSM207F-20	2.1	—

OUTPUT RPM	GEARBOX SIZE†	MIN INPUT SHAFT SHEAVE P.D. (in.)	COOLING METHOD
2 HP Motor (cont.)			
15 - 17	HSM207F-14	3.1	—
18 - 20	HSM207F-25	1.7	—
	HSM207F-20	2.1	—
	HSM207F-14	3.2	—
21 - 22	HSM203E-25	2.2	—
	HSM203E-20	2.7	—
	HSM203E-14	4.1	—
23 - 24	HSM203E-25	2.3	—
	HSM203E-20	2.7	—
	HSM203E-14	4.1	—
	HSM203E-09	5.7	—
25 - 26	HSM203E-25	2.4	—
	HSM203E-20	2.7	—
	HSM203E-14	4.1	—
	HSM203E-09	5.7	—
27	HSM203E-25	2.5	—
	HSM203E-20	2.8	—
	HSM203E-14	4.1	—
	HSM203E-09	5.7	—
28	HSM203E-25	2.5	—
	HSM203E-20	2.9	—
	HSM203E-14	4.1	—
	HSM203E-09	5.6	—
29 - 30	HSM203E-25	2.6	—
	HSM203E-20	2.9	—
	HSM203E-14	4.1	—
	HSM203E-09	5.6	—
31 - 32	HSM203E-25	2.6	—
	HSM203E-20	3.0	—
	HSM203E-14	4.1	—
	HSM203E-09	5.7	—
33	HSM115D-25	2.3	—
	HSM115D-20	2.5	—
	HSM115D-14	3.5	—
	HSM115D-09	5.3	—
34	HSM115D-25	2.4	—
	HSM115D-20	2.6	—
	HSM115D-14	3.5	—
	HSM115D-09	5.2	—
35 - 38	HSM115D-25	2.4	—
	HSM115D-20	2.6	—
	HSM115D-14	3.4	—
	HSM115D-09	5.2	—
39	HSM115D-25	2.4	—
	HSM115D-20	2.7	—
	HSM115D-14	3.4	—
	HSM115D-09	5.1	—
40	HSM115D-25	2.4	—
	HSM115D-20	2.7	—
	HSM115D-14	3.5	—
	HSM115D-09	5.1	—
41 - 44	HSM115D-25	2.4	—
	HSM115D-20	2.7	—
	HSM115D-14	3.4	—
	HSM115D-09	5.1	—
45	HSM115D-25	2.4	—
	HSM115D-20	2.7	—
	HSM115D-14	3.4	—
	HSM115D-09	4.9	—
46 - 47	HSM115D-25	2.4	—

NOTE: †Consult factory for delivery of units with 9:1 and 20:1 ratios.

HSM Speed Reducer Selection (SF = 2.0) CLASS III

OUTPUT RPM	GEARBOX SIZE†	MIN INPUT SHAFT SHEAVE P.D. (in.)	COOLING METHOD
2 HP Motor (cont.)			
46 - 47	HSM115D-20	2.7	—
	HSM115D-14	3.5	—
	HSM115D-09	4.9	—
48 - 49	HSM115D-25	2.4	—
	HSM115D-20	2.7	—
	HSM115D-14	3.5	—
	HSM115D-09	4.8	—
50 - 54	HSM115D-25	2.5	—
	HSM115D-20	2.7	—
	HSM115D-14	3.5	—
	HSM115D-09	4.8	—
55 - 59	HSM115D-25	2.5	—
	HSM115D-20	2.7	—
	HSM115D-14	3.5	—
	HSM115D-09	4.6	—
60 - 61	HSM107C-25	1.8	—
	HSM107C-20	2.0	—
	HSM107C-14	2.6	—
	HSM115D-09	4.6	—
62 - 65	HSM107C-25	1.8	—
	HSM107C-20	2.0	—
	HSM107C-14	2.6	—
	HSM107C-09	3.3	—
66 - 68	HSM107C-25	1.9	—
	HSM107C-20	2.0	—
	HSM107C-14	2.7	—
	HSM107C-09	3.3	—
69 - 70	HSM107C-25	1.9	—
	HSM107C-20	2.0	—
	HSM107C-14	2.7	—
	HSM107C-09	3.4	—
71 - 74	HSM107C-25	1.9	—
	HSM107C-20	2.1	—
	HSM107C-14	2.7	—
	HSM107C-09	3.4	—
75	HSM107C-25	1.9	—
	HSM107C-20	2.1	—
	HSM107C-14	2.8	—
	HSM107C-09	3.5	—
76	HSM107C-25	2.0	—
	HSM107C-20	2.1	—
	HSM107C-14	2.8	—
	HSM107C-09	3.4	—
77 - 79	HSM107C-25	2.0	—
	HSM107C-20	2.2	—
	HSM107C-14	2.8	—
	HSM107C-09	3.4	—
80	HSM107C-25	2.0	—
	HSM107C-20	2.2	—
	HSM107C-14	2.9	—
	HSM107C-09	3.4	—
81 - 83	HSM107C-25	2.0	—
	HSM107C-20	2.2	—
	HSM107C-14	2.9	—
	HSM107C-09	3.5	—
84 - 86	HSM107C-25	2.1	—
	HSM107C-20	2.2	—
	HSM107C-14	2.9	—
	HSM107C-09	3.5	—
87 - 90	HSM107C-20	2.3	—

OUTPUT RPM	GEARBOX SIZE†	MIN INPUT SHAFT SHEAVE P.D. (in.)	COOLING METHOD
2 HP Motor (cont.)			
87 - 90	HSM107C-14	2.9	—
	HSM107C-09	3.5	—
91 - 93	HSM107C-20	2.3	—
	HSM107C-14	3.0	—
	HSM107C-09	3.5	—
94 - 97	HSM107C-20	2.3	—
	HSM107C-14	3.0	—
	HSM107C-09	3.6	—
98 - 99	HSM107C-20	2.3	—
	HSM107C-14	2.9	—
	HSM107C-09	3.7	—
100	HSM107C-14	2.9	—
	HSM107C-09	3.7	—
	HSM107C-05	5.6	—
101 - 102	HSM107C-09	3.7	—
	HSM107C-05	5.5	—
103 - 116	HSM107C-09	3.6	—
	HSM107C-05	5.5	—
117 - 220	HSM107C-09	3.6	—
	HSM107C-05	5.3	—
221 - 328	HSM107C-05	5.2	—
329 - 400	HSM107C-05	5.4	—
3 HP Motor			
10	HSM307H-25	2.0	—
	HSM307H-20	2.4	—
	HSM307H-14	3.7	—
11 - 12	HSM307H-25	2.0	—
	HSM307H-20	2.5	—
	HSM307H-14	3.7	—
13 - 14	HSM215G-25	2.4	—
	HSM215G-20	2.9	—
	HSM215G-14	4.5	—
15 - 20	HSM215G-25	2.4	—
	HSM215G-20	3.0	—
	HSM215G-14	4.5	—
21	HSM215G-25	2.5	—
	HSM215G-20	3.0	—
	HSM215G-14	4.6	—
22 - 25	HSM207F-25	1.8	—
	HSM207F-20	2.1	—
	HSM207F-14	3.2	—
26 - 27	HSM207F-25	1.9	—
	HSM207F-20	2.2	—
	HSM207F-14	3.2	—
28 - 30	HSM207F-25	2.0	—
	HSM207F-20	2.2	—
	HSM207F-14	3.2	—
31 - 33	HSM203E-25	2.6	—
	HSM203E-20	3.0	—
	HSM203E-14	4.1	—
34	HSM203E-25	2.7	—
	HSM203E-20	3.0	—
	HSM203E-14	4.1	—
	HSM203E-09	5.8	—
35	HSM203E-25	2.7	—
	HSM203E-20	3.0	—
	HSM203E-14	4.0	—
	HSM203E-09	5.9	—
36 - 37	HSM203E-25	2.7	—
	HSM203E-20	3.1	—

OUTPUT RPM	GEARBOX SIZE†	MIN INPUT SHAFT SHEAVE P.D. (in.)	COOLING METHOD
3 HP Motor (cont.)			
36 - 37	HSM203E-14	4.0	—
	HSM203E-09	5.8	—
38 - 41	HSM203E-25	2.7	—
	HSM203E-20	3.1	—
	HSM203E-14	4.0	—
	HSM203E-09	5.6	—
42 - 43	HSM203E-25	2.8	—
	HSM203E-20	3.1	—
	HSM203E-14	4.1	—
	HSM203E-09	5.4	—
44 - 48	HSM203E-25	2.8	—
	HSM203E-20	3.2	—
	HSM203E-14	4.1	—
	HSM203E-09	5.4	—
49 - 54	HSM203E-25	2.8	—
	HSM203E-20	3.2	—
	HSM203E-14	4.1	—
	HSM203E-09	5.3	—
55	HSM203E-25	2.8	—
	HSM203E-20	3.2	—
	HSM203E-14	4.2	—
	HSM203E-09	5.3	—
56 - 61	HSM115D-25	2.5	—
	HSM115D-20	2.7	—
	HSM115D-14	3.5	—
	HSM115D-09	4.6	—
62 - 65	HSM115D-25	2.5	—
	HSM115D-20	2.7	—
	HSM115D-14	3.6	—
	HSM115D-09	4.6	—
66 - 67	HSM115D-25	2.5	—
	HSM115D-20	2.8	—
	HSM115D-14	3.6	—
	HSM115D-09	4.7	—
68 - 71	HSM115D-25	2.6	—
	HSM115D-20	2.8	—
	HSM115D-14	3.6	—
	HSM115D-09	4.7	—
72	HSM115D-25	2.6	—
	HSM115D-20	2.8	—
	HSM115D-14	3.7	—
	HSM115D-09	4.8	—
73 - 74	HSM115D-25	2.6	—
	HSM115D-20	2.9	—
	HSM115D-14	3.7	—
	HSM115D-09	4.8	—
75 - 76	HSM115D-25	2.7	—
	HSM115D-20	2.9	—
	HSM115D-14	3.8	—
	HSM115D-09	4.9	—
77 - 79	HSM115D-25	2.7	—
	HSM115D-20	3.0	—
	HSM115D-14	3.8	—
	HSM115D-09	4.9	—
80 - 83	HSM115D-25	2.8	—
	HSM115D-20	3.0	—
	HSM115D-14	3.9	—
	HSM115D-09	5.0	—
84	HSM115D-25	2.8	—
	HSM115D-20	3.1	—

NOTE: †Consult factory for delivery of units with 9:1 and 20:1 ratios.

CLASS III HSM Speed Reducer Selection (SF = 2.0)

OUTPUT RPM	GEARBOX SIZE†	MIN INPUT SHAFT SHEAVE P.D. (in.)	COOLING METHOD
3 HP Motor (cont.)			
84	HSM115D-14	3.9	—
	HSM115D-09	5.1	—
85 - 86	HSM115D-25	2.8	—
	HSM115D-20	3.1	—
	HSM115D-14	3.9	—
	HSM115D-09	5.2	—
87 - 91	HSM115D-20	3.1	—
	HSM115D-14	4.0	—
	HSM115D-09	5.2	—
92 - 97	HSM107C-20	2.3	—
	HSM107C-14	3.0	—
	HSM115D-09	5.3	—
98	HSM107C-20	2.3	—
	HSM107C-14	2.9	—
	HSM115D-09	5.2	—
99	HSM107C-20	2.3	—
	HSM107C-14	2.9	—
	HSM107C-09	3.7	—
100	HSM107C-14	2.9	—
	HSM107C-09	3.7	—
	HSM107C-05	5.6	—
101 - 102	HSM107C-09	3.7	—
	HSM107C-05	5.5	—
103 - 116	HSM107C-09	3.6	—
	HSM107C-05	5.5	—
117 - 220	HSM107C-09	3.6	—
	HSM107C-05	5.3	—
221 - 328	HSM107C-05	5.2	—
329 - 400	HSM107C-05	5.4	—
5 HP Motor			
10	HSM315J-25	2.8	—
	HSM315J-20	3.4	—
	HSM315J-14	5.2	—
11 - 12	HSM315J-25	2.8	—
	HSM315J-20	3.5	—
	HSM315J-14	5.2	—
13	HSM315J-25	2.9	—
	HSM315J-20	3.5	—
	HSM315J-14	5.3	—
14	HSM315J-25	2.9	—
	HSM315J-20	3.6	—
	HSM315J-14	5.4	—
15 - 16	HSM307H-25	2.1	—
	HSM307H-20	2.5	—
	HSM307H-14	3.8	—
17 - 20	HSM307H-25	2.1	—
	HSM307H-20	2.6	—
	HSM307H-14	3.9	—
21 - 22	HSM215G-25	2.5	—
	HSM215G-20	3.0	—
	HSM215G-14	4.6	—
23	HSM215G-25	2.6	—
	HSM215G-20	3.0	—
	HSM215G-14	4.6	—
24	HSM215G-25	2.6	—
	HSM215G-20	3.0	—
	HSM215G-14	4.7	—
25 - 26	HSM215G-25	2.7	—
	HSM215G-20	3.1	—
	HSM215G-14	4.7	—

OUTPUT RPM	GEARBOX SIZE†	MIN INPUT SHAFT SHEAVE P.D. (in.)	COOLING METHOD
5 HP Motor (cont.)			
27 - 29	HSM215G-25	2.7	—
	HSM215G-20	3.2	—
	HSM215G-14	4.7	—
30 - 32	HSM215G-25	2.9	—
	HSM215G-20	3.3	—
	HSM215G-14	4.7	—
33	HSM215G-25	2.9	—
	HSM215G-20	3.3	—
	HSM215G-14	4.6	—
34	HSM215G-25	2.9	—
	HSM215G-20	3.4	—
	HSM215G-14	4.6	—
35	HSM215G-25	3.0	—
	HSM215G-20	3.4	—
	HSM215G-14	4.6	—
36	HSM207F-25	2.1	—
	HSM207F-20	2.4	—
	HSM207F-14	3.2	—
37	HSM207F-25	2.1	—
	HSM207F-20	2.4	—
	HSM207F-14	3.1	—
38 - 44	HSM207F-25	2.1	—
	HSM207F-20	2.4	—
	HSM207F-14	3.2	—
45 - 50	HSM207F-25	2.1	—
	HSM207F-20	2.5	—
	HSM207F-14	3.2	—
51 - 60	HSM207F-25	2.2	—
	HSM207F-20	2.5	—
	HSM207F-14	3.2	—
61	HSM203E-25	2.9	—
	HSM203E-20	3.2	—
	HSM203E-14	4.2	—
62 - 66	HSM203E-25	2.9	—
	HSM203E-20	3.2	—
	HSM203E-14	4.2	—
67 - 71	HSM203E-09	5.4	—
	HSM203E-25	3.0	—
	HSM203E-20	3.3	—
	HSM203E-14	4.3	—
	HSM203E-09	5.4	—
72	HSM203E-25	3.1	—
	HSM203E-20	3.4	—
	HSM203E-14	4.3	—
	HSM203E-09	5.5	—
73	HSM203E-25	3.1	—
	HSM203E-20	3.4	—
	HSM203E-14	4.4	—
	HSM203E-09	5.5	—
74	HSM203E-25	3.2	—
	HSM203E-20	3.4	—
	HSM203E-14	4.4	—
	HSM203E-09	5.6	—
75 - 76	HSM203E-25	3.2	—
	HSM203E-20	3.5	—
	HSM203E-14	4.4	—
	HSM203E-09	5.6	—
77	HSM203E-25	3.3	—
	HSM203E-20	3.5	—
	HSM203E-14	4.5	—

OUTPUT RPM	GEARBOX SIZE†	MIN INPUT SHAFT SHEAVE P.D. (in.)	COOLING METHOD
5 HP Motor (cont.)			
77	HSM203E-09	5.7	—
78	HSM203E-25	3.3	—
	HSM203E-20	3.6	—
	HSM203E-14	4.5	—
	HSM203E-09	5.7	—
79 - 80	HSM203E-25	3.4	—
	HSM203E-20	3.6	—
	HSM203E-14	4.5	—
	HSM203E-09	5.7	—
81	HSM203E-20	3.6	—
	HSM203E-14	4.6	—
	HSM203E-09	5.8	—
82 - 83	HSM203E-20	3.7	—
	HSM203E-14	4.6	—
	HSM203E-09	5.8	—
84 - 85	HSM203E-20	3.7	—
	HSM203E-14	4.6	—
	HSM203E-09	5.9	—
86 - 89	HSM203E-20	3.8	—
	HSM203E-14	4.7	—
	HSM203E-09	5.9	—
90 - 93	HSM203E-20	3.9	—
	HSM203E-14	4.7	—
	HSM203E-09	6.0	—
94 - 99	HSM203E-20	4.0	—
	HSM203E-14	4.8	—
	HSM203E-09	6.0	—
100	HSM203E-14	4.7	—
	HSM203E-09	6.0	—
	HSM203E-05	8.7	—
101 - 106	HSM203E-09	6.0	—
	HSM203E-05	8.7	—
107 - 111	HSM115D-09	5.1	—
	HSM115D-05	7.4	—
112 - 124	HSM115D-09	5.1	—
	HSM115D-05	7.3	—
125 - 142	HSM115D-09	4.9	—
	HSM115D-05	7.2	—
143 - 147	HSM115D-09	4.9	—
	HSM115D-05	7.1	—
148 - 152	HSM115D-09	4.9	—
	HSM115D-05	7.2	—
153 - 220	HSM115D-09	4.9	—
	HSM115D-05	7.1	—
221 - 231	HSM115D-05	7.1	—
232 - 328	HSM107C-05	5.2	—
329 - 400	HSM107C-05	5.4	—
7 1/2 HP Motor			
10	HSM415K-25	3.7	—
	HSM415K-20	4.4	—
	HSM415K-14	6.6	—
11	HSM407S-25	2.9	—
	HSM407S-20	3.5	—
	HSM407S-14	5.3	—
12 - 14	HSM407S-25	2.9	—
	HSM407S-20	3.6	—
	HSM407S-14	5.4	—
15 - 18	HSM315J-25	2.9	—
	HSM315J-20	3.6	—
	HSM315J-14	5.4	—

NOTE: †Consult factory for delivery of units with 9:1 and 20:1 ratios.

HSM Speed Reducer Selection (SF = 2.0) CLASS III

OUTPUT RPM	GEARBOX SIZE†	MIN INPUT SHAFT SHEAVE P.D. (in.)	COOLING METHOD
7 1/2 HP Motor (cont.)			
19	HSM315J-25	3.0	—
	HSM315J-20	3.6	—
	HSM315J-14	5.5	—
20 - 21	HSM315J-25	3.0	—
	HSM315J-20	3.7	—
	HSM315J-14	5.5	—
22 - 25	HSM307H-25	2.2	—
	HSM307H-20	2.6	—
	HSM307H-14	3.9	—
26	HSM307H-25	2.3	—
	HSM307H-20	2.7	—
	HSM307H-14	4.0	—
27 - 29	HSM307H-25	2.4	—
	HSM307H-20	2.7	—
	HSM307H-14	4.0	—
30	HSM307H-25	2.5	—
	HSM307H-20	2.8	—
	HSM307H-14	4.0	—
31 - 32	HSM215G-25	2.9	—
	HSM215G-20	3.3	—
	HSM215G-14	4.7	—
33	HSM215G-25	2.9	—
	HSM215G-20	3.3	—
	HSM215G-14	4.6	—
34	HSM215G-25	2.9	—
	HSM215G-20	3.4	—
	HSM215G-14	4.6	—
35 - 37	HSM215G-25	3.0	—
	HSM215G-20	3.4	—
	HSM215G-14	4.6	—
38 - 39	HSM215G-25	3.0	—
	HSM215G-20	3.5	—
	HSM215G-14	4.6	—
40 - 53	HSM215G-25	3.1	—
	HSM215G-20	3.5	—
	HSM215G-14	4.6	—
54 - 57	HSM215G-25	3.1	—
	HSM215G-20	3.5	—
	HSM215G-14	4.7	—
58 - 60	HSM215G-25	3.1	—
	HSM215G-20	3.6	—
	HSM215G-14	4.7	—
61 - 62	HSM215G-25	3.2	—
	HSM215G-20	3.6	—
	HSM215G-14	4.7	—
63 - 69	HSM207F-25	2.2	—
	HSM207F-20	2.5	—
	HSM207F-14	3.3	—
70 - 71	HSM207F-25	2.2	—
	HSM207F-20	2.6	—
	HSM207F-14	3.3	—
72 - 74	HSM207F-25	2.3	—
	HSM207F-20	2.6	—
	HSM207F-14	3.4	—
75	HSM207F-25	2.3	—
	HSM207F-20	2.7	—
	HSM207F-14	3.4	—
76	HSM207F-25	2.3	—
	HSM207F-20	2.7	—
	HSM207F-14	3.5	—

OUTPUT RPM	GEARBOX SIZE†	MIN INPUT SHAFT SHEAVE P.D. (in.)	COOLING METHOD
7 1/2 HP Motor (cont.)			
77 - 80	HSM207F-25	2.4	—
	HSM207F-20	2.7	—
	HSM207F-14	3.5	—
81 - 89	HSM207F-20	2.8	—
	HSM207F-14	3.6	—
90 - 91	HSM207F-20	2.8	—
	HSM207F-14	3.7	—
92 - 93	HSM207F-20	2.9	—
	HSM207F-14	3.7	—
94 - 97	HSM203E-20	4.0	—
	HSM203E-14	4.8	—
98 - 99	HSM203E-20	4.0	—
	HSM203E-14	4.7	—
	HSM203E-09	6.0	—
100	HSM203E-14	4.7	—
	HSM203E-09	6.0	—
	HSM203E-05	8.7	—
101 - 109	HSM203E-09	6.0	—
	HSM203E-05	8.7	—
110 - 121	HSM203E-09	5.9	—
	HSM203E-05	8.5	—
122 - 165	HSM203E-09	5.8	—
	HSM203E-05	8.4	—
166 - 192	HSM203E-09	5.8	—
	HSM203E-05	8.2	—
193 - 204	HSM203E-09	5.7	—
	HSM203E-05	8.3	—
205 - 216	HSM203E-09	5.7	—
	HSM203E-05	8.2	—
217	HSM203E-09	5.8	—
	HSM115D-05	7.1	—
218 - 220	HSM115D-09	4.9	—
	HSM115D-05	7.1	—
221 - 275	HSM115D-05	7.1	—
276 - 343	HSM115D-05	7.2	—
344 - 398	HSM115D-05	7.4	—
399 - 400	HSM115D-05	7.6	—
10 HP Motor			
10 - 11	HSM507L-25	5.0	—
	HSM507L-20	6.3	—
	HSM507L-14	9.3	—
12	HSM415K-25	3.8	—
	HSM415K-20	4.5	—
	HSM415K-14	6.8	—
13	HSM415K-25	3.8	—
	HSM415K-20	4.5	—
	HSM415K-14	6.9	—
14	HSM415K-25	3.9	—
	HSM415K-20	4.6	—
	HSM415K-14	6.9	—
15	HSM407S-25	3.0	—
	HSM407S-20	3.6	—
	HSM407S-14	5.5	—
16 - 18	HSM407S-25	3.0	—
	HSM407S-20	3.7	—
	HSM407S-14	5.5	—
19	HSM315J-25	3.0	—
	HSM315J-20	3.6	—
	HSM315J-14	5.5	—
20 - 21	HSM315J-25	3.0	—

OUTPUT RPM	GEARBOX SIZE†	MIN INPUT SHAFT SHEAVE P.D. (in.)	COOLING METHOD
10 HP Motor (cont.)			
20-21	HSM315J-20	3.7	—
	HSM315J-14	5.5	—
22 - 23	HSM315J-25	3.1	—
	HSM315J-20	3.7	—
	HSM315J-14	5.5	—
24 - 27	HSM315J-25	3.2	—
	HSM315J-20	3.7	—
	HSM315J-14	5.6	—
28	HSM315J-25	3.4	—
	HSM315J-20	3.9	—
	HSM315J-14	5.6	—
29	HSM307H-25	2.4	—
	HSM307H-20	2.8	—
	HSM307H-14	4.0	—
30 - 31	HSM307H-25	2.5	—
	HSM307H-20	2.8	—
	HSM307H-14	4.0	—
32	HSM307H-25	2.5	—
	HSM307H-20	2.8	—
	HSM307H-14	3.9	—
33 - 36	HSM307H-25	2.5	—
	HSM307H-20	2.9	—
	HSM307H-14	3.9	—
37	HSM307H-25	2.6	—
	HSM307H-20	2.9	—
	HSM307H-14	3.9	—
38 - 43	HSM307H-25	2.6	—
	HSM307H-20	3.0	—
	HSM307H-14	3.9	—
44 - 53	HSM215G-25	3.1	—
	HSM215G-20	3.5	—
	HSM215G-14	4.6	—
54 - 57	HSM215G-25	3.1	—
	HSM215G-20	3.5	—
	HSM215G-14	4.7	—
58 - 60	HSM215G-25	3.1	—
	HSM215G-20	3.6	—
	HSM215G-14	4.7	—
61 - 70	HSM215G-25	3.2	—
	HSM215G-20	3.6	—
	HSM215G-14	4.7	—
71	HSM215G-25	3.2	—
	HSM215G-20	3.7	—
	HSM215G-14	4.8	—
72 - 75	HSM215G-25	3.2	—
	HSM215G-20	3.7	—
	HSM215G-14	4.9	—
76	HSM215G-25	3.4	—
	HSM215G-20	3.8	—
	HSM215G-14	5.0	—
77 - 79	HSM215G-25	3.4	—
	HSM215G-20	3.9	—
	HSM215G-14	5.0	—
80	HSM215G-25	3.5	—
	HSM215G-20	3.9	—
	HSM215G-14	5.1	—
81	HSM215G-20	3.9	—
	HSM215G-14	5.1	—
82	HSM215G-20	4.0	—
	HSM215G-14	5.1	—

NOTE: †Consult factory for delivery of units with 9:1 and 20:1 ratios.

CLASS III HSM Speed Reducer Selection (SF = 2.0)

OUTPUT RPM	GEARBOX SIZE†	MIN INPUT SHAFT SHEAVE P.D. (in.)	COOLING METHOD
10 HP Motor (cont.)			
83 - 84	HSM215G-20	4.0	—
	HSM215G-14	5.2	—
85 - 89	HSM207F-20	2.8	—
	HSM207F-14	3.6	—
90 - 91	HSM207F-20	2.8	—
	HSM207F-14	3.7	—
92 - 97	HSM207F-20	2.9	—
	HSM207F-14	3.7	—
98 - 99	HSM207F-20	2.8	—
	HSM207F-14	3.6	—
100	HSM207F-14	3.6	—
	HSM207F-05	6.8	—
101 - 113	HSM207F-05	6.8	—
114 - 156	HSM207F-05	6.6	—
157 - 166	HSM207F-05	6.4	—
167	HSM203E-05	8.2	—
168 - 192	HSM203E-09	5.8	—
	HSM203E-05	8.2	—
193 - 204	HSM203E-09	5.7	—
	HSM203E-05	8.3	—
205 - 220	HSM203E-09	5.7	—
	HSM203E-05	8.2	—
221 - 244	HSM203E-05	8.2	—
245 - 292	HSM203E-05	8.3	—
293 - 327	HSM203E-05	8.5	—
328 - 343	HSM115D-05	7.3	—
344 - 398	HSM115D-05	7.4	—
399 - 400	HSM115D-05	7.6	—
15 HP Motor			
10 - 15	HSM507L-25	5.0	—
	HSM507L-20	6.3	—
	HSM507L-14	9.3	—
16 - 18	HSM415K-25	3.9	—
	HSM415K-20	4.6	—
	HSM415K-14	7.0	—
19 - 20	HSM415K-25	4.0	—
	HSM415K-20	4.7	—
	HSM415K-14	7.1	—
21 - 22	HSM407S-25	3.1	—
	HSM407S-20	3.7	—
	HSM407S-14	5.6	—
23 - 26	HSM407S-25	3.2	—
	HSM407S-20	3.8	—
	HSM407S-14	5.7	—
27	HSM407S-25	3.4	—
	HSM407S-20	3.9	—
	HSM407S-14	5.7	—
28	HSM315J-25	3.4	—
	HSM315J-20	3.9	—
	HSM315J-14	5.6	—
29	HSM315J-25	3.5	—
	HSM315J-20	3.9	—
	HSM315J-14	5.6	—
30 - 31	HSM315J-20	3.5	—
	HSM315J-20	4.0	—
	HSM315J-14	5.6	—
32 - 35	HSM315J-25	3.6	—
	HSM315J-20	4.0	—
	HSM315J-14	5.6	—
36	HSM315J-25	3.6	—

OUTPUT RPM	GEARBOX SIZE†	MIN INPUT SHAFT SHEAVE P.D. (in.)	COOLING METHOD
15 HP Motor (cont.)			
36	HSM315J-20	4.2	—
	HSM315J-14	5.5	—
37 - 46	HSM315J-25	3.7	—
	HSM315J-20	4.2	—
	HSM315J-14	5.4	—
47 - 54	HSM307H-25	2.6	—
	HSM307H-20	3.0	—
	HSM307H-14	3.9	—
55 - 57	HSM307H-25	2.6	—
	HSM307H-20	3.0	—
	HSM307H-14	4.0	—
58 - 63	HSM307H-25	2.7	—
	HSM307H-20	3.0	—
	HSM307H-14	4.0	—
64 - 71	HSM307H-25	2.7	—
	HSM307H-20	3.1	—
	HSM307H-14	4.0	—
72 - 73	HSM307H-25	2.8	—
	HSM307H-20	3.2	—
	HSM307H-14	4.1	—
74 - 75	HSM215G-25	3.3	—
	HSM215G-20	3.8	—
	HSM215G-14	4.9	—
76	HSM215G-25	3.4	—
	HSM215G-20	3.8	—
	HSM215G-14	5.0	—
77 - 79	HSM215G-25	3.4	—
	HSM215G-20	3.9	—
	HSM215G-14	5.0	—
80	HSM215G-25	3.5	—
	HSM215G-20	3.9	—
	HSM215G-14	5.1	—
81	HSM215G-20	3.9	—
	HSM215G-14	5.1	—
82	HSM215G-20	4.0	—
	HSM215G-14	5.1	—
83 - 85	HSM215G-20	4.0	—
	HSM215G-14	5.2	—
86 - 94	HSM215G-14	5.2	—
95	HSM215G-14	5.4	—
96 - 99	HSM215G-14	5.3	—
100	HSM215G-14	5.2	—
	HSM215G-05	9.8	—
101 - 110	HSM215G-05	9.7	—
111 - 126	HSM215G-05	9.5	—
127 - 152	HSM215G-05	9.3	—
153 - 173	HSM215G-05	9.2	—
174 - 307	HSM207F-05	6.4	—
308 - 360	HSM203E-05	8.5	—
361 - 382	HSM203E-05	8.7	—
383 - 400	HSM203E-05	8.8	—
20 HP Motor			
10 - 11	HSM608M-25	10.0	—
	HSM608M-20	11.5	—
	HSM608M-14	17.5	—
12 - 15	HSM507L-25	5.0	—
	HSM507L-20	6.3	—
	HSM507L-14	9.3	—
16 - 20	HSM507L-25	5.0	—
	HSM507L-20	6.3	—

OUTPUT RPM	GEARBOX SIZE†	MIN INPUT SHAFT SHEAVE P.D. (in.)	COOLING METHOD
20 HP Motor (cont.)			
16 - 20	HSM507L-14	9.0	—
21 - 23	HSM415K-25	4.0	—
	HSM415K-20	4.7	—
	HSM415K-14	7.1	—
24 - 26	HSM415K-25	4.2	—
	HSM415K-20	4.7	—
	HSM415K-14	7.2	—
27	HSM415K-25	4.4	—
	HSM415K-20	4.9	—
	HSM415K-14	7.2	—
28	HSM407S-25	3.5	—
	HSM407S-20	3.9	—
	HSM407S-14	5.7	—
29	HSM407S-25	3.5	—
	HSM407S-20	4.0	—
	HSM407S-14	5.7	—
30 - 32	HSM407S-25	3.6	—
	HSM407S-20	4.0	—
	HSM407S-14	5.7	—
33	HSM407S-25	3.6	—
	HSM407S-20	4.1	—
	HSM407S-14	5.6	—
34	HSM407S-25	3.6	—
	HSM407S-20	4.2	—
	HSM407S-14	5.6	—
35 - 38	HSM407S-25	3.7	—
	HSM407S-20	4.2	—
	HSM407S-14	5.6	—
39 - 57	HSM315J-25	3.7	—
	HSM315J-20	4.2	—
	HSM315J-14	5.5	—
58	HSM315J-25	3.9	—
	HSM315J-20	4.3	—
	HSM315J-14	5.7	—
59 - 68	HSM315J-25	3.9	—
	HSM315J-20	4.4	—
	HSM315J-14	5.7	—
69 - 71	HSM307H-25	2.7	—
	HSM307H-20	3.1	—
	HSM307H-14	4.0	—
72 - 73	HSM307H-25	2.8	—
	HSM307H-20	3.2	—
	HSM307H-14	4.1	—
74 - 76	HSM307H-25	2.8	—
	HSM307H-20	3.2	—
	HSM307H-14	4.2	—
77 - 80	HSM307H-25	2.9	—
	HSM307H-20	3.3	—
	HSM307H-14	4.2	—
81 - 82	HSM307H-14	4.3	—
83 - 99	HSM307H-14	4.4	—
100	HSM307H-14	4.4	—
	HSM307H-05	8.4	—
101 - 106	HSM307H-05	8.4	—
107	HSM307H-05	8.2	—
108 - 116	HSM215G-05	9.6	—
117 - 152	HSM215G-05	9.4	—
153 - 269	HSM215G-05	9.2	—
270 - 308	HSM207F-05	6.4	—
309 - 358	HSM207F-05	6.6	—

NOTE: †Consult factory for delivery of units with 9:1 and 20:1 ratios.

HSM Speed Reducer Selection (SF = 2.0) CLASS III

OUTPUT RPM	GEARBOX SIZE†	MIN INPUT SHAFT SHEAVE P.D. (in.)	COOLING METHOD
20 HP Motor (cont.)			
359 - 400	HSM207F-05	6.7	—
25 HP Motor			
10 - 11	HSM608M-25	10.0	—
	HSM608M-20	11.5	—
	HSM608M-14	17.5	—
12 - 13	HSM608M-25	10.0	—
	HSM608M-20	11.5	—
	HSM608M-14	17.3	—
14	HSM608M-25	9.8	—
	HSM608M-20	11.5	—
	HSM608M-14	17.3	—
15	HSM507L-25	5.0	—
	HSM507L-20	6.3	—
	HSM507L-14	9.3	—
16 - 21	HSM507L-25	5.0	—
	HSM507L-20	6.3	—
	HSM507L-14	9.0	—
22 - 24	HSM507L-25	5.0	—
	HSM507L-20	6.0	—
	HSM507L-14	9.0	—
25	HSM507L-25	5.3	—
	HSM507L-20	6.0	—
	HSM507L-14	9.0	—
26	HSM415K-25	4.3	—
	HSM415K-20	4.8	—
	HSM415K-14	7.2	—
27 - 29	HSM415K-25	4.4	—
	HSM415K-20	4.9	—
	HSM415K-14	7.2	—
30 - 32	HSM415K-25	4.6	—
	HSM415K-20	5.0	—
	HSM415K-14	7.2	—
33	HSM415K-25	4.7	—
	HSM415K-20	5.1	—
	HSM415K-14	7.1	—
34	HSM415K-25	4.7	—
	HSM415K-20	5.2	—
	HSM415K-14	7.1	—
35 - 47	HSM407S-25	3.7	—
	HSM407S-20	4.2	—
	HSM407S-14	5.6	—
48 - 50	HSM407S-25	3.8	—
	HSM407S-20	4.4	—
	HSM407S-14	5.6	—
51 - 52	HSM407S-25	3.8	—
	HSM407S-20	4.4	—
	HSM407S-14	5.7	—
53 - 57	HSM315J-25	3.8	—
	HSM315J-20	4.3	—
	HSM315J-14	5.6	—
58	HSM315J-25	3.9	—
	HSM315J-20	4.3	—
	HSM315J-14	5.7	—
59 - 70	HSM315J-25	3.9	—
	HSM315J-20	4.4	—
	HSM315J-14	5.7	—
71	HSM315J-25	4.0	—
	HSM315J-20	4.5	—
	HSM315J-14	5.8	—
72 - 74	HSM315J-25	4.0	—

OUTPUT RPM	GEARBOX SIZE†	MIN INPUT SHAFT SHEAVE P.D. (in.)	COOLING METHOD
25 HP Motor (cont.)			
72 - 74	HSM315J-20	4.6	—
	HSM315J-14	5.9	—
75 - 76	HSM407S-25	4.1	—
	HSM407S-20	4.7	—
	HSM315J-14	6.0	—
77 - 78	HSM407S-25	4.2	—
	HSM407S-20	4.7	—
	HSM315J-14	6.1	—
79 - 84	HSM315J-14	6.2	—
85 - 99	HSM307H-14	4.4	—
100	HSM307H-14	4.4	—
	HSM307H-05	8.4	—
101 - 106	HSM307H-05	8.4	—
107 - 120	HSM307H-05	8.2	—
121 - 162	HSM307H-05	8.0	—
163	HSM307H-05	7.8	—
164 - 278	HSM215G-05	9.2	—
279 - 340	HSM215G-05	9.3	—
341 - 365	HSM215G-05	9.5	—
366 - 400	HSM207F-05	6.7	—
30 HP Motor			
10 - 11	HSM608M-25	10.0	—
	HSM608M-20	11.5	—
	HSM608M-14	17.5	—
12 - 13	HSM608M-25	10.0	—
	HSM608M-20	11.5	—
	HSM608M-14	17.3	—
14 - 15	HSM608M-25	9.8	—
	HSM608M-20	11.5	—
	HSM608M-14	17.3	—
16 - 17	HSM608M-25	9.8	—
	HSM608M-20	11.5	—
	HSM608M-14	17.0	—
18 - 21	HSM507L-25	5.0	—
	HSM507L-20	6.3	—
	HSM507L-14	9.0	—
22 - 24	HSM507L-25	5.0	—
	HSM507L-20	6.0	—
	HSM507L-14	9.0	—
25 - 26	HSM507L-25	5.3	—
	HSM507L-20	6.0	—
	HSM507L-14	9.0	—
27 - 30	HSM507L-25	5.3	—
	HSM507L-20	6.3	—
	HSM507L-14	8.8	—
31 - 32	HSM415K-25	4.6	—
	HSM415K-20	5.1	—
	HSM415K-14	7.2	—
33	HSM415K-25	4.7	—
	HSM415K-20	5.1	—
	HSM415K-14	7.1	—
34 - 38	HSM415K-25	4.7	—
	HSM415K-20	5.2	—
	HSM415K-14	7.1	—
39 - 41	HSM415K-25	4.8	—
	HSM415K-20	5.4	—
	HSM415K-14	7.0	—
42 - 43	HSM415K-25	4.9	—
	HSM415K-20	5.4	—
	HSM415K-14	7.0	—

OUTPUT RPM	GEARBOX SIZE†	MIN INPUT SHAFT SHEAVE P.D. (in.)	COOLING METHOD
30 HP Motor (cont.)			
44 - 47	HSM407S-25	3.8	—
	HSM407S-20	4.3	—
	HSM407S-14	5.6	—
48 - 50	HSM407S-25	3.8	—
	HSM407S-20	4.4	—
	HSM407S-14	5.6	—
51 - 57	HSM407S-25	3.8	—
	HSM407S-20	4.4	—
	HSM407S-14	5.7	—
58 - 66	HSM407S-25	3.9	—
	HSM407S-20	4.4	—
	HSM407S-14	5.7	—
67 - 70	HSM315J-25	3.9	—
	HSM315J-20	4.4	—
	HSM315J-14	5.7	—
71	HSM315J-25	4.0	—
	HSM315J-20	4.5	—
	HSM315J-14	5.8	—
72 - 74	HSM315J-25	4.0	—
	HSM315J-20	4.6	—
	HSM315J-14	5.9	—
75 - 76	HSM407S-25	4.1	—
	HSM407S-20	4.7	—
	HSM315J-14	6.0	—
77 - 78	HSM407S-25	4.2	—
	HSM407S-20	4.7	—
	HSM315J-14	6.1	—
79 - 87	HSM315J-14	6.2	—
88 - 99	HSM315J-14	6.4	—
100	HSM315J-14	6.4	—
	HSM315J-05	11.8	—
101 - 102	HSM315J-05	11.8	—
103 - 111	HSM315J-05	11.7	—
112 - 117	HSM315J-05	11.5	—
118 - 137	HSM307H-05	8.1	—
138 - 162	HSM307H-05	7.9	—
163 - 218	HSM307H-05	7.8	—
219 - 278	HSM215G-05	9.1	—
279 - 340	HSM215G-05	9.3	—
341 - 387	HSM215G-05	9.5	—
388 - 400	HSM215G-05	9.7	—
40 HP Motor			
14 - 15	HSM608M-25	9.8	—
	HSM608M-20	11.5	—
	HSM608M-14	17.3	—
16 - 17	HSM608M-25	9.8	—
	HSM608M-20	11.5	—
	HSM608M-14	17.0	—
18 - 19	HSM608M-25	9.8	—
	HSM608M-20	11.3	—
	HSM608M-14	17.0	—
20 - 23	HSM608M-25	9.8	—
	HSM608M-20	11.3	—
	HSM608M-14	16.8	—
24	HSM507L-25	5.0	—
	HSM507L-20	6.0	—
	HSM507L-14	9.0	—
25 - 26	HSM507L-25	5.3	—
	HSM507L-20	6.0	—
	HSM507L-14	9.0	—

NOTE: †Consult factory for delivery of units with 9:1 and 20:1 ratios.

CLASS III HSM Speed Reducer Selection (SF = 2.0)

OUTPUT RPM	GEARBOX SIZE†	MIN INPUT SHAFT SHEAVE P.D. (in.)	COOLING METHOD
40 HP Motor (cont.)			
27 - 30	HSM507L-25	5.3	—
	HSM507L-20	6.3	—
	HSM507L-14	8.8	—
31 - 32	HSM507L-25	5.5	—
	HSM507L-20	6.3	—
	HSM507L-14	8.8	—
33 - 34	HSM507L-25	5.5	—
	HSM507L-20	6.5	—
	HSM507L-14	8.8	—
35 - 38	HSM507L-25	5.8	—
	HSM507L-20	6.5	—
	HSM507L-14	8.8	—
39 - 44	HSM507L-25	5.8	—
	HSM507L-20	6.8	—
	HSM507L-14	8.8	—
45 - 50	HSM415K-25	4.8	—
	HSM415K-20	5.4	—
	HSM415K-14	7.0	—
51 - 55	HSM415K-25	4.9	—
	HSM415K-20	5.4	—
	HSM415K-14	7.1	—
56 - 64	HSM415K-25	4.9	—
	HSM415K-20	5.4	—
	HSM415K-14	7.2	—
65 - 70	HSM407S-25	3.9	—
	HSM407S-20	4.4	—
	HSM407S-14	5.8	—
71 - 73	HSM407S-25	4.0	—
	HSM407S-20	4.5	—
	HSM407S-14	5.9	—
74 - 76	HSM407S-25	4.1	—
	HSM407S-20	4.7	—
	HSM407S-14	6.0	—
77	HSM407S-25	4.2	—
	HSM407S-20	4.7	—
	HSM407S-14	6.1	—
78	HSM407S-25	4.2	—
	HSM407S-20	4.8	—
	HSM407S-14	6.2	—
79 - 85	HSM407S-14	6.2	—
86 - 88	HSM407S-14	6.4	—
89 - 99	HSM315J-14	6.4	—
100	HSM315J-14	6.4	—
	HSM315J-05	11.8	—
101 - 102	HSM315J-05	11.8	—
103 - 111	HSM315J-05	11.7	—
112 - 126	HSM315J-05	11.5	—
127 - 154	HSM315J-05	11.3	—
155 - 194	HSM315J-05	11.2	—
195 - 277	HSM307H-05	7.8	—
278 - 329	HSM307H-05	7.9	—
330 - 366	HSM215G-05	9.4	—
367 - 400	HSM215G-05	9.6	—
50 HP Motor			
17	HSM608M-25	9.8	—
	HSM608M-20	11.5	—
	HSM608M-14	17.0	—
18 - 19	HSM608M-25	9.8	—
	HSM608M-20	11.3	—
	HSM608M-14	17.0	—

OUTPUT RPM	GEARBOX SIZE†	MIN INPUT SHAFT SHEAVE P.D. (in.)	COOLING METHOD
50 HP Motor (cont.)			
20 - 23	HSM608M-25	9.8	—
	HSM608M-20	11.3	—
	HSM608M-14	16.8	—
24 - 28	HSM608M-25	10.0	—
	HSM608M-20	11.0	—
	HSM608M-14	16.5	—
29	HSM608M-25	10.3	—
	HSM608M-20	11.3	—
	HSM608M-14	16.3	—
30	HSM507L-25	5.3	—
	HSM507L-20	6.3	—
	HSM507L-14	8.8	—
31 - 32	HSM507L-25	5.5	—
	HSM507L-20	6.3	—
	HSM507L-14	8.8	—
33 - 34	HSM507L-25	5.5	—
	HSM507L-20	6.5	—
	HSM507L-14	8.8	—
35 - 38	HSM507L-25	5.8	—
	HSM507L-20	6.5	—
	HSM507L-14	8.8	—
39 - 46	HSM507L-25	5.8	—
	HSM507L-20	6.8	—
	HSM507L-14	8.8	—
47 - 52	HSM507L-25	6.0	—
	HSM507L-20	7.0	—
	HSM507L-14	9.0	—
53 - 58	HSM507L-25	6.0	—
	HSM507L-20	7.0	—
	HSM507L-14	9.3	—
59 - 60	HSM507L-14	9.3	—
61 - 70	HSM415K-25	5.0	—
	HSM415K-20	5.5	—
	HSM415K-14	7.2	—
71	HSM415K-25	5.1	—
	HSM415K-20	5.6	—
	HSM415K-14	7.4	—
72 - 73	HSM415K-25	5.1	—
	HSM415K-20	5.7	—
	HSM415K-14	7.4	—
74	HSM415K-25	5.2	—
	HSM415K-20	5.8	—
	HSM415K-14	7.5	—
75 - 76	HSM415K-14	7.6	—
77 - 80	HSM415K-14	7.7	—
81 - 85	HSM407S-14	6.3	—
86 - 99	HSM407S-14	6.4	—
100	HSM407S-14	6.3	—
	HSM407S-05	12.1	—
101 - 107	HSM407S-05	12.0	—
108 - 112	HSM407S-05	11.8	—
113 - 125	HSM407S-05	11.7	—
126 - 137	HSM407S-05	11.5	—
138 - 154	HSM315J-05	11.3	—
155 - 257	HSM315J-05	11.2	—
258 - 272	HSM315J-05	11.3	—
273 - 277	HSM307H-05	7.8	—
278 - 356	HSM307H-05	7.9	—
357 - 400	HSM307H-05	8.1	—

OUTPUT RPM	GEARBOX SIZE†	MIN INPUT SHAFT SHEAVE P.D. (in.)	COOLING METHOD
60 HP Motor			
21 - 23	HSM608M-25	9.8	—
	HSM608M-20	11.3	—
	HSM608M-14	16.8	—
24 - 28	HSM608M-25	10.0	—
	HSM608M-20	11.0	—
	HSM608M-14	16.5	—
29 - 30	HSM608M-25	10.3	—
	HSM608M-20	11.3	—
	HSM608M-14	16.3	—
31 - 32	HSM608M-25	10.3	—
	HSM608M-20	11.5	—
	HSM608M-14	16.3	—
33 - 34	HSM608M-25	10.5	—
	HSM608M-20	11.5	—
	HSM608M-14	16.0	—
35 - 36	HSM608M-25	10.8	—
	HSM608M-20	12.0	—
	HSM608M-14	16.0	—
37 - 38	HSM507L-25	5.8	—
	HSM507L-20	6.5	—
	HSM507L-14	8.8	—
39 - 46	HSM507L-25	5.8	—
	HSM507L-20	6.8	—
	HSM507L-14	8.8	—
47 - 52	HSM507L-25	6.0	—
	HSM507L-20	7.0	—
	HSM507L-14	9.0	—
53 - 58	HSM507L-25	6.0	—
	HSM507L-20	7.0	—
	HSM507L-14	9.3	—
59 - 66	HSM507L-14	9.3	—
67 - 74	HSM415K-14	9.5	—
75 - 76	HSM415K-14	7.6	—
77 - 81	HSM415K-14	7.7	—
82 - 90	HSM415K-14	7.9	—
91 - 98	HSM415K-14	8.1	—
99	HSM415K-14	7.9	—
100	HSM415K-14	7.9	—
	HSM415K-05	16.0	—
101 - 103	HSM415K-05	15.9	—
104 - 105	HSM415K-05	15.7	—
106 - 107	HSM415K-05	15.5	—
108 - 112	HSM407S-05	11.8	—
113 - 125	HSM407S-05	11.7	—
126 - 161	HSM407S-05	11.5	—
162 - 187	HSM407S-05	11.3	—
188 - 257	HSM315J-05	11.2	—
258 - 289	HSM315J-05	11.3	—
290 - 338	HSM315J-05	11.5	—
339 - 349	HSM315J-05	11.7	—
350 - 381	HSM307H-05	8.0	—
382 - 400	HSM315J-05	11.9	—
75 HP Motor			
26 - 28	HSM608M-25	10.0	—
	HSM608M-20	11.0	—
	HSM608M-14	16.5	—
29 - 30	HSM608M-25	10.3	—
	HSM608M-20	11.3	—
	HSM608M-14	16.3	—
31 - 32	HSM608M-25	10.3	—

NOTE: †Consult factory for delivery of units with 9:1 and 20:1 ratios.

HSM Speed Reducer Selection (SF = 2.0) CLASS III

OUTPUT RPM	GEARBOX SIZE [†]	MIN INPUT SHAFT SHEAVE P.D. (in.)	COOLING METHOD
75 HP Motor (cont.)			
31 - 32	HSM608M-20	11.5	—
	HSM608M-14	16.3	—
33 - 34	HSM608M-25	10.5	—
	HSM608M-20	11.5	—
	HSM608M-14	16.0	—
35 - 37	HSM608M-25	10.8	—
	HSM608M-20	12.0	—
	HSM608M-14	16.0	—
38 - 40	HSM608M-25	10.8	—
	HSM608M-20	12.0	—
	HSM608M-14	15.8	—
41 - 42	HSM608M-25	11.0	—
	HSM608M-20	12.0	—
	HSM608M-14	15.8	—
43 - 46	HSM608M-25	11.3	—
	HSM608M-20	12.5	—
	HSM608M-14	16.0	—
47	HSM608M-25	11.3	—
	HSM608M-20	12.5	—
	HSM608M-14	16.3	—
48 - 52	HSM507L-25	6.0	—
	HSM507L-20	7.0	—
	HSM507L-14	9.0	—
53 - 58	HSM507L-25	6.0	—
	HSM507L-20	7.0	—
	HSM507L-14	9.3	—
59 - 66	HSM507L-14	9.3	—
67 - 79	HSM507L-14	9.5	—
80 - 84	HSM507L-14	8.8	—
85 - 89	HSM507L-14	7.5	—
90 - 93	HSM507L-14	6.5	—
94 - 98	HSM415K-14	8.1	—
99	HSM415K-14	7.9	—
100	HSM415K-14	7.9	—
	HSM415K-05	16.0	—
101 - 103	HSM415K-05	15.9	—
104 - 105	HSM415K-05	15.7	—
106 - 110	HSM415K-05	15.5	—
111 - 113	HSM415K-05	15.3	—
114 - 121	HSM415K-05	15.2	—
122 - 133	HSM415K-05	15.0	—
134 - 145	HSM415K-05	14.8	—
146 - 163	HSM415K-05	14.7	—

OUTPUT RPM	GEARBOX SIZE [†]	MIN INPUT SHAFT SHEAVE P.D. (in.)	COOLING METHOD
75 HP Motor (cont.)			
164 - 227	HSM407S-05	11.3	—
228 - 233	HSM407S-05	11.2	—
234 - 262	HSM407S-05	11.3	—
263 - 289	HSM315J-05	11.3	—
290 - 338	HSM315J-05	11.5	—
339 - 358	HSM315J-05	11.7	—
359 - 388	HSM315J-05	11.8	—
389 - 399	HSM315J-05	12.0	—
400	HSM315J-05	12.0	—
100 HP Motor			
36 - 37	HSM608M-25	10.8	—
	HSM608M-20	12.0	—
	HSM608M-14	16.0	—
38 - 40	HSM608M-25	10.8	—
	HSM608M-20	12.0	—
	HSM608M-14	15.8	—
41 - 42	HSM608M-25	11.0	—
	HSM608M-20	12.0	—
	HSM608M-14	15.8	—
43 - 46	HSM608M-25	11.3	—
	HSM608M-20	12.5	—
	HSM608M-14	16.0	—
47 - 50	HSM608M-25	11.3	—
	HSM608M-20	12.5	—
	HSM608M-14	16.3	—
51 - 52	HSM608M-25	11.3	—
	HSM608M-20	12.8	—
	HSM608M-14	16.5	—
53 - 54	HSM608M-25	11.5	—
	HSM608M-20	12.8	—
	HSM608M-14	16.8	—
55 - 67	HSM608M-14	17.0	—
68 - 79	HSM507L-14	9.5	—
80 - 84	HSM507L-14	8.8	—
85 - 89	HSM507L-14	7.5	—
90 - 94	HSM507L-14	6.5	—
95 - 100	HSM507L-14	6.0	—
167 - 230	HSM415K-05	14.7	—
231 - 255	HSM415K-05	14.5	—
256 - 284	HSM407S-05	11.3	—
285 - 341	HSM407S-05	11.5	—
342 - 362	HSM407S-05	11.7	—

OUTPUT RPM	GEARBOX SIZE [†]	MIN INPUT SHAFT SHEAVE P.D. (in.)	COOLING METHOD
100 HP Motor (cont.)			
363 - 388	HSM407S-05	11.8	—
389 - 398	HSM315J-05	12.0	Fan
399 - 400	HSM407S-05	12.0	—
125 HP Motor			
47 - 50	HSM608M-25	11.3	—
	HSM608M-20	12.5	—
	HSM608M-14	16.3	—
51 - 52	HSM608M-25	11.3	—
	HSM608M-20	12.8	—
	HSM608M-14	16.5	—
53 - 54	HSM608M-25	11.5	—
	HSM608M-20	12.8	—
	HSM608M-14	16.8	—
55 - 70	HSM608M-14	17.0	—
71 - 79	HSM608M-14	17.3	—
80 - 84	HSM608M-14	15.0	—
85 - 88	HSM608M-14	12.8	—
89	HSM608M-14	12.8	Fan
90	HSM608M-14	11.0	Fan
91 - 94	HSM507L-14	6.5	—
95 - 100	HSM507L-14	6.0	—
237 - 281	HSM415K-05	14.5	—
282 - 297	HSM415K-05	14.7	—
298 - 325	HSM415K-05	14.8	—
326 - 347	HSM415K-05	15.0	—
348 - 362	HSM407S-05	11.7	—
363 - 381	HSM407S-05	11.8	—
382 - 400	HSM407S-05	11.9	Fan
150 HP Motor			
59 - 70	HSM608M-14	17.0	—
71 - 79	HSM608M-14	17.3	—
80 - 84	HSM608M-14	15.0	—
85 - 87	HSM608M-14	12.8	—
88 - 89	HSM608M-14	12.8	Fan
308 - 325	HSM415K-05	14.8	—
326 - 376	HSM415K-05	15.0	—
377 - 383	HSM415K-05	15.2	—
384 - 391	HSM415K-05	15.2	Fan
392 - 400	HSM415K-05	15.3	Fan
200 HP Motor			
85 - 87	HSM608M-14	12.8	Fan

NOTE: [†]Consult factory for delivery of units with 9:1 and 20:1 ratios.

Power Rating (Input HP)

5:1 SINGLE REDUCTION UNITS⁽¹⁾

OUTPUT RPM	HSM107C	HSM115D	HSM203E	HSM207F	HSM215G	HSM307H	HSM315J	HSM407S	HSM415K
100	6.20	9.71	15.2	22.3	38.6	55.4	85.2	115.9	152.5
110	6.49	10.2	15.9	23.4	40.4	58.1	89.2	121.3	159.6
120	6.77	10.6	16.7	24.4	42.2	60.6	93.2	126.8	166.7
130	7.07	11.1	17.4	25.4	44.0	63.2	97.1	132.1	174.0
140	7.36	11.5	18.1	26.5	45.8	65.9	101.1	137.5	181.1
150	7.65	12.0	18.8	27.5	47.6	68.4	105.2	142.9	188.2
160	7.94	12.4	19.5	28.6	49.4	71.0	109.1	148.4	195.3
170	8.22	12.9	20.2	29.6	51.2	73.6	113.1	153.7	202.4
180	8.52	13.3	20.9	30.7	53.1	76.2	117.1	159.1	209.5
190	8.81	13.8	21.6	31.7	54.8	78.7	121.0	164.6	216.6
200	9.09	14.2	22.3	32.7	56.7	81.3	125.0	170.0	223.7
210	9.39	14.7	23.1	33.8	58.5	84.0	129.0	175.3	230.9
220	9.67	15.1	23.8	34.8	60.3	86.5	132.9	180.8	238.0
230	9.97	15.6	24.5	35.9	62.1	89.1	137.0	186.2	245.1
240	10.2	16.1	25.2	36.9	63.9	91.8	140.8	191.5	252.2
250	10.5	16.5	25.9	37.9	65.7	94.3	144.9	197.0	259.3
260	10.8	17.0	26.6	39.0	67.5	96.8	148.9	202.4	266.5
270	11.1	17.4	27.3	40.0	69.3	99.4	152.8	207.8	273.6
280	11.4	17.9	28.0	41.1	71.1	102.1	156.8	213.3	280.8
290	11.7	18.3	28.7	42.1	72.9	104.6	160.8	218.6	287.9
300	12.0	18.8	29.5	43.2	74.7	107.2	164.7	224.0	295.0
310	12.3	19.2	30.2	44.2	76.5	109.9	168.7	229.5	302.1
320	12.6	19.7	30.9	45.2	78.3	112.4	172.8	234.9	309.2
330	12.9	20.1	31.6	46.3	80.1	115.0	176.7	240.2	316.3
340	13.1	20.6	32.3	47.3	81.9	117.6	180.7	245.6	323.4
350	13.4	21.0	33.0	48.4	83.7	120.2	184.7	251.1	330.5
360	13.7	21.5	33.7	49.4	85.5	122.7	188.1	256.5	337.6
370	14.0	21.9	34.4	50.5	87.3	125.3	179.3	261.8	327.8
380	14.3	22.4	35.1	51.5	89.1	121.1	169.8	253.3	308.0
390	14.6	22.9	35.9	52.5	90.9	113.9	159.8	236.2	286.9
400	14.9	23.3	36.6	53.6	91.0	106.0	149.0	218.2	264.9
Torque at 100 RPM (ft-lb)	325	510	800	1172	2029	2910	4474	6087	8010

14:1 DOUBLE REDUCTION UNITS⁽¹⁾

OUTPUT RPM	HSM107C	HSM115D	HSM203E	HSM207F	HSM215G	HSM307H	HSM315J	HSM407S	HSM415K	HSM507L	HSM608M
10	0.72	1.14	1.80	2.63	4.55	6.52	10.0	13.6	17.9	34.9	61.7
12	0.89	1.40	2.20	3.22	5.58	8.00	12.3	16.7	22.0	41.6	73.2
14	1.06	1.66	2.60	3.82	6.61	9.48	14.6	19.8	26.1	48.3	84.8
16	1.22	1.92	3.01	4.42	7.64	11.0	16.8	22.9	30.1	55.0	96.3
18	1.39	2.18	3.42	5.01	8.66	12.4	19.1	26.0	34.2	61.7	107.8
20	1.56	2.44	3.82	5.61	9.68	13.9	21.4	29.1	38.3	68.4	119.4
22	1.72	2.70	4.23	6.20	10.7	15.4	23.7	32.2	42.3	74.8	129.8
24	1.89	2.96	4.64	6.79	11.7	16.9	25.9	35.2	46.4	81.3	140.3
26	2.05	3.21	5.04	7.38	12.8	18.4	28.2	38.3	50.5	87.7	150.8
28	2.22	3.47	5.45	7.98	13.8	19.8	30.5	41.4	54.5	94.2	161.2
30	2.39	3.73	5.85	8.57	14.8	21.3	32.7	44.5	58.6	100.6	171.7
32	2.52	3.94	6.18	9.05	15.7	22.5	34.5	47.0	61.8	106.2	181.6
34	2.66	4.15	6.50	9.53	16.5	23.7	36.4	49.4	65.1	111.9	191.5
38	2.92	4.56	7.15	10.5	18.1	26.0	40.0	54.4	71.6	123.1	211.4
40	3.04	4.76	7.47	11.0	19.0	27.2	41.8	56.8	74.8	128.8	221.3
42	3.15	4.92	7.72	11.3	19.6	28.1	43.2	58.7	77.3	134.4	230.2
46	3.35	5.23	8.21	12.0	20.8	29.9	45.9	62.4	82.2	145.7	247.9
50	3.54	5.54	8.69	12.7	22.0	31.6	48.6	66.1	87.0	156.9	265.6
52	3.64	5.70	8.94	13.1	22.7	32.5	50.0	68.0	89.5	162.0	274.2
54	3.75	5.85	9.19	13.5	23.3	33.4	51.4	69.8	91.9	167.1	282.8
58	3.94	6.16	9.67	14.2	24.5	35.2	54.1	73.5	96.8	177.3	299.9
62	4.14	6.47	10.2	14.9	25.7	37.0	56.8	77.2	101.7	187.3	316.3
66	4.34	6.78	10.6	15.6	27.0	38.7	59.5	80.9	106.6	196.9	331.9
70	4.53	7.10	11.1	16.3	28.2	40.5	62.3	84.6	111.4	206.6	347.4
74	4.85	7.58	11.9	17.4	30.1	43.3	66.5	90.4	119.0	215.7	362.4
78	5.15	8.05	12.6	18.5	32.0	46.0	70.7	96.1	126.5	224.8	377.5
80	5.30	8.29	13.0	19.1	33.0	47.4	72.8	99.0	130.3	229.4	385.0
85	5.59	8.77	13.8	20.2	34.9	50.1	76.9	104.6	137.6	239.4	387.0
90	5.90	9.24	14.5	21.2	36.8	52.8	81.1	110.2	145.1	249.5	210.6
95	6.20	9.71	15.2	22.3	38.6	55.5	85.2	115.9	152.5	258.2	141.1
100	6.20	9.71	15.2	22.3	38.6	55.5	85.8	115.9	152.5	266.9	65.1
Torque at 10 RPM (ft-lb)	380	599	944	1381	2388	3424	5270	7158	9426	18,317	32,407

Note: [1] Power ratings highlighted in bold indicate that the power is constrained by thermal limitations. Please consult factory for ratings with cooling fans.

Power Rating (Input HP)

20:1 DOUBLE REDUCTION UNITS⁽¹⁾

OUTPUT RPM	HSM107C	HSM115D	HSM203E	HSM207F	HSM215G	HSM307H	HSM315J	HSM407S	HSM415K	HSM507L	HSM608M
10	0.72	1.14	1.80	2.63	4.55	6.52	10.0	13.6	17.9	34.9	61.7
12	0.89	1.40	2.20	3.22	5.58	8.00	12.3	16.7	22.0	41.6	73.2
14	1.06	1.66	2.60	3.82	6.61	9.48	14.6	19.8	26.1	48.3	84.8
16	1.22	1.92	3.01	4.42	7.64	11.0	16.8	22.9	30.1	55.0	96.3
18	1.39	2.18	3.42	5.01	8.66	12.4	19.1	26.0	34.2	61.7	107.8
20	1.56	2.44	3.82	5.61	9.68	13.9	21.4	29.1	38.3	68.4	119.4
22	1.72	2.70	4.23	6.20	10.7	15.4	23.7	32.2	42.3	74.8	129.8
24	1.89	2.96	4.64	6.79	11.7	16.9	25.9	35.2	46.4	81.3	140.3
26	2.05	3.21	5.04	7.38	12.8	18.4	28.2	38.3	50.5	87.7	150.8
28	2.22	3.47	5.45	7.98	13.8	19.8	30.5	41.4	54.5	94.2	161.2
30	2.39	3.73	5.85	8.57	14.8	21.3	32.7	44.5	58.6	100.6	171.7
32	2.52	3.94	6.18	9.05	15.7	22.5	34.5	47.0	61.8	106.2	181.6
34	2.66	4.15	6.50	9.53	16.5	23.7	36.4	49.4	65.1	111.9	191.5
38	2.92	4.56	7.15	10.5	18.1	26.0	40.0	54.4	71.6	123.1	211.4
40	3.04	4.76	7.47	11.0	19.0	27.2	41.8	56.8	74.8	128.8	221.3
42	3.15	4.92	7.72	11.3	19.6	28.1	43.2	58.7	77.3	134.4	230.2
46	3.35	5.23	8.21	12.0	20.8	29.9	45.9	62.4	82.2	145.7	247.9
50	3.54	5.54	8.69	12.7	22.0	31.6	48.6	66.1	87.0	156.9	265.6
52	3.64	5.70	8.94	13.1	22.7	32.5	50.0	68.0	89.5	162.0	274.2
54	3.75	5.85	9.19	13.5	23.3	33.4	51.4	69.8	91.9	167.1	282.8
58	3.94	6.16	9.67	14.2	24.5	35.2	54.1	73.5	96.8	177.3	
62	4.14	6.47	10.2	14.9	25.7	37.0	56.8	77.2	101.7		
66	4.34	6.78	10.6	15.6	27.0	38.7	59.5	80.9	106.6		
70	4.53	7.10	11.1	16.3	28.2	40.5	62.3	84.6	111.4		
74	4.85	7.58	11.9	17.4	30.1	43.3	66.5	90.4	119.0		
78	5.15	8.05	12.6	18.5	32.0	46.0		96.1			
80	5.30	8.29	13.0	19.1	33.0	47.4					
85	5.59	8.77	13.8	20.2	34.9						
90	5.90	9.24	14.5	21.2							
95	6.20	9.71	15.2	22.3							
99	6.20	9.71	15.2	22.3							
Torque at 10 RPM (ft-lb)	380	599	944	1381	2388	3424	5270	7158	9426	18,317	32,407

Note: [1] Shaded cells indicate output speeds that are restricted to 14:1 ratio units only. They are too high for 20:1 ratio units.

25:1 DOUBLE REDUCTION UNITS⁽²⁾

OUTPUT RPM	HSM107C	HSM115D	HSM203E	HSM207F	HSM215G	HSM307H	HSM315J	HSM407S	HSM415K	HSM507L	HSM608M
10	0.72	1.14	1.80	2.63	4.55	6.52	10.0	13.6	17.9	34.9	61.7
12	0.89	1.40	2.20	3.22	5.58	8.00	12.3	16.7	22.0	41.6	73.2
14	1.06	1.66	2.60	3.82	6.61	9.48	14.6	19.8	26.1	48.3	84.8
16	1.22	1.92	3.01	4.42	7.64	11.0	16.8	22.9	30.1	55.0	96.3
18	1.39	2.18	3.42	5.01	8.66	12.4	19.1	26.0	34.2	61.7	107.8
20	1.56	2.44	3.82	5.61	9.68	13.9	21.4	29.1	38.3	68.4	119.4
22	1.72	2.70	4.23	6.20	10.7	15.4	23.7	32.2	42.3	74.8	129.8
24	1.89	2.96	4.64	6.79	11.7	16.9	25.9	35.2	46.4	81.3	140.3
26	2.05	3.21	5.04	7.38	12.8	18.4	28.2	38.3	50.5	87.7	150.8
28	2.22	3.47	5.45	7.98	13.8	19.8	30.5	41.4	54.5	94.2	161.2
30	2.39	3.73	5.85	8.57	14.8	21.3	32.7	44.5	58.6	100.6	171.7
32	2.52	3.94	6.18	9.05	15.7	22.5	34.5	47.0	61.8	106.2	181.6
34	2.66	4.15	6.50	9.53	16.5	23.7	36.4	49.4	65.1	111.9	191.5
38	2.92	4.56	7.15	10.5	18.1	26.0	40.0	54.4	71.6	123.1	211.4
40	3.04	4.76	7.47	11.0	19.0	27.2	41.8	56.8	74.8	128.8	221.3
42	3.15	4.92	7.72	11.3	19.6	28.1	43.2	58.7	77.3	134.4	230.2
46	3.35	5.23	8.21	12.0	20.8	29.9	45.9	62.4	82.2	145.7	247.9
50	3.54	5.54	8.69	12.7	22.0	31.6	48.6	66.1	87.0	156.9	265.6
52	3.64	5.70	8.94	13.1	22.7	32.5	50.0	68.0	89.5	162.0	274.2
54	3.75	5.85	9.19	13.5	23.3	33.4	51.4	69.8	91.9	167.1	282.8
58	3.94	6.16	9.67	14.2	24.5	35.2	54.1	73.5	96.8	177.3	
62	4.14	6.47	10.2	14.9	25.7	37.0	56.8	77.2	101.7		
66	4.34	6.78	10.6	15.6	27.0	38.7	59.5	80.9	106.6		
70	4.53	7.10	11.1	16.3	28.2	40.5	62.3	84.6	111.4		
74	4.85	7.58	11.9	17.4	30.1	43.3	66.5	90.4	119.0		
78	5.15	8.05	12.6	18.5	32.0	46.0		96.1			
80	5.30	8.29	13.0	19.1	33.0	47.4					
85	5.59	8.77		20.2	34.9						
86	5.66	8.87									
87 +											
Torque at 10 RPM (ft-lb)	380	599	944	1381	2388	3424	5270	7158	9426	18,317	32,407

Note: [2] Shaded cells indicate output speeds that are restricted to 14:1 ratio units only. They are too high for 25:1 ratio units.

CEMA Screw Conveyor Drive

Use the Selection Table below to select a Screw Conveyor Drive Shaft Assembly and Mounting Adapter.

1. Based on the **Reducer Size**, **Screw Conveyor Diameter**, and preferred **Drive Shaft Diameter**, find the **Drive Shaft Assembly** part number.
2. Specify the corresponding **Mounting Adapter** part number.
3. **Optional:** For **Top Mount** motor applications, select a **Motor bracket** part number and (optional) **Belt Guard** part number based on the Reducer Size and NEMA Motor Frame size.

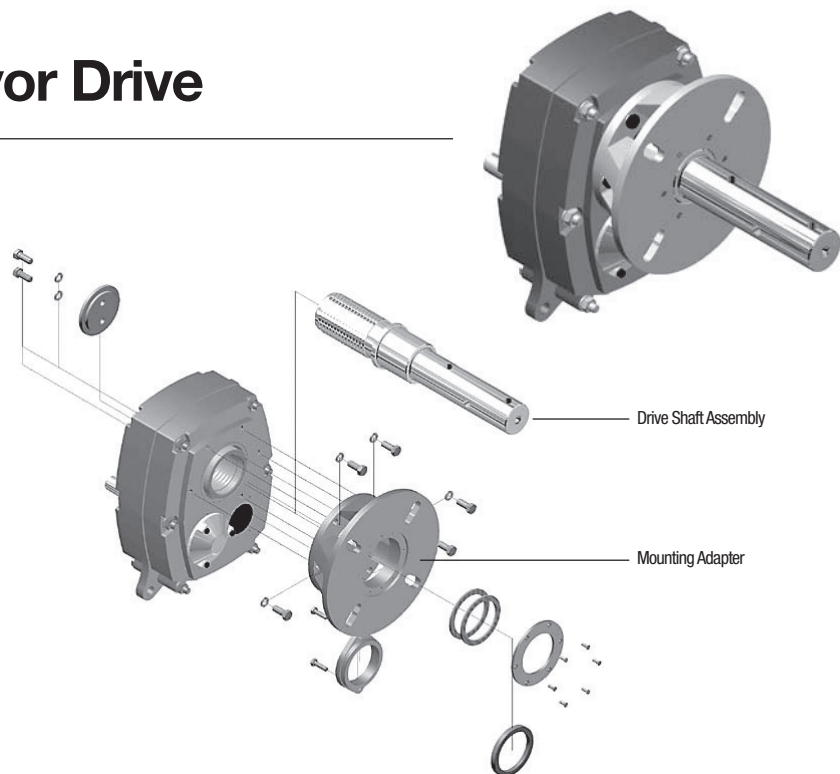

Selection Table

Drive Shaft Assembly and Mounting Adapter					Optional Top Mount Motor Parts			
Reducer Size	Screw Conveyor Diameter (inches)	Drive Shaft Diameter (inches)	PART NO. Drive Shaft Assembly	PART NO. Mounting Adapter	NEMA Motor Frame Range	PART NO. Top Mount	PART NO. Top Mount Belt Guard (Optional)	PART NO. Side Mount Belt Guard (Optional)
107C	6 - 9 ^[1]	1-1/2"	116C4108-C3	116C4041	56~184T	116C0220-X	116C6061-X	116C6161-X
	9 - 12	2"	116C4200-C3	116C4040				
	12 - 14	2-7/16"	116C4207-C3					
115D	6 - 9 ^[1]	1-1/2"	116D4108-C3	116D4041	56~215T	116D0220-X	116D6061-X	116D6161-X
	9 - 12	2"	116D4200-C3	116D4040				
	12 - 14	2-7/16"	116D4207-C3					
203E	6 - 9 ^[1]	1-1/2"	116E4108-C3	116E4041	56~215T	116E0220-X	116E6061-X	116E6161-X
	9 - 12	2"	116E4200-C3	116E4040				
	12 - 14	2-7/16"	116E4207-C3					
207F	6 - 9 ^[1]	1-1/2"	116F4108-C3	116F4041	56~215T	116F0220-X	116F6061-X	116F6161-X
	9 - 12	2"	116F4200-C3	116F4040				
	12 - 14	2-7/16"	116F4207-C3					
215G	9 - 12	2"	116G4200-C3	116G4040	143T~286T	116G0220-X	116G6061-X	116G6161-X
	12 - 14	2-7/16"	116G4207-C3					
	12 - 20	3"	116G4300-C3					
307H	9 - 12	2"	116H4200-C3	116H4040	143T~286T	116H0220-X	116H6061-X	116H6161-X
	12 - 14	2-7/16"	116H4207-C3					
	12 - 20	3"	116H4300-C3					
315J	12 - 14	2-7/16"	116J4207-C3	116J4040	143T~326T	116J0220-X	116J6061-X	116J6161-X
	12 - 20	3"	116J4300-C3					
	18 - 24	3-7/16"	116J4307-C3					
407S	12 - 14	2-7/16"	116S4207-C3	116S4040	143T~326T	116S0220-X	116S6061-X	116S6161-X
	12 - 20	3"	116S4300-C3					
	18 - 24	3-7/16"	116S4307-C3					

Note: [1] See view on page 49 for Frame Sizes 107C, 115D, 203E, and 207F, 1-1/2" Shaft with 6-9" Screw Diameter.

CEMA Screw Conveyor Drive Dimensions

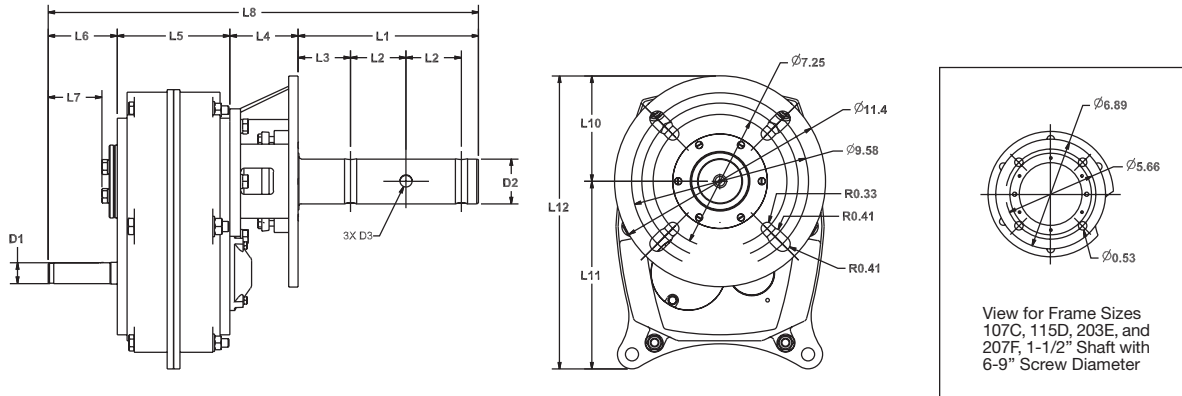

Dimensions shown are for reference only and are subject to change without notice, unless certified.

Certified prints are available after receipt of an order; consult factory.

Dimensions (inches)

Unit	107C				115D				203E				207F			
D2	Ø1-1/2"	Ø2"	Ø2-7/16"	Ø3"	Ø1-1/2"	Ø2"	Ø2-7/16"	Ø3"	Ø1-1/2"	Ø2"	Ø2-7/16"	Ø3"	Ø1-1/2"	Ø2"	Ø2-7/16"	Ø3"
Screw Dia.	6-9" [1]	9-12"	12-14"	12-20"	6-9" [1]	9-12"	12-14"	12-20"	6-9" [1]	9-12"	12-14"	12-20"	6-9" [1]	9-12"	12-14"	12-20"
D1	3/4	3/4	3/4	3/4	15/16	15/16	15/16	15/16	1-1/16	1-1/16"	1-1/16	1-1/16	1-1/8	1-1/8	1-1/8	1-1/8
D3	17/32	21/32	21/32	25/32	17/32	21/32	21/32	25/32	17/32	21/32	21/32	25/32	17/32	21/32	21/32	25/32
D4	6.89	11.42	11.42	11.42	6.89	11.4	11.4	11.4	6.89	11.4	11.4	11.4	11.4	11.4	11.4	11.4
L1	9.00	9.00	9.69	9.88	9.00	9.00	9.69	9.88	9.00	9.00	9.69	9.88	9.00	9.00	9.69	9.88
L2	3.00	3.00	3.00	3.00	3.00	3.00	3.00	3.00	3.00	3.00	3.00	3.00	3.00	3.00	3.00	3.00
L3	2.13	2.13	2.76	2.87	2.13	2.13	2.76	2.87	2.13	2.13	2.76	2.87	2.13	2.13	2.76	2.87
L4	3.22	3.22	3.22	3.22	3.22	3.22	3.22	3.22	3.56	3.56	3.56	3.56	3.69	3.69	3.69	3.69
L5	4.65	4.65	4.65	4.65	5.00	5.00	5.00	5.00	5.31	5.31	5.31	5.31	6.10	6.10	6.10	6.10
L6	2.87	2.87	2.87	2.87	3.23	3.23	3.23	3.23	3.43	3.43	3.43	3.43	3.74	3.74	3.74	3.74
L7	1.41	1.41	1.41	1.41	2.48	2.48	2.48	2.48	2.60	2.60	2.60	2.60	2.91	2.91	2.91	2.91
L8	19.74	19.74	20.43	20.61	20.4	20.4	21.1	21.3	21.3	21.3	22.0	22.2	22.5	22.5	23.2	23.4
L10	3.50	5.71	5.71	5.71	3.50	5.71	5.71	5.71	3.50	5.71	5.71	5.71	5.71	5.71	5.71	5.71
L11	6.02	6.02	6.02	6.02	7.28	7.28	7.28	7.28	8.50	8.50	8.50	8.50	10.2	10.2	10.2	10.2
L12	9.52	11.73	11.73	11.73	10.8	13.0	13.0	13.0	12.0	14.2	14.2	14.2	15.9	15.9	15.9	15.9

Unit	215G				307H				315J			407S		
D2	Ø2"	Ø2-7/16"	Ø3"	Ø3-7/16"	Ø2"	Ø2-7/16"	Ø3"	Ø3-7/16"	Ø2-7/16"	Ø3"	Ø3-7/16"	Ø2-7/16"	Ø3"	Ø3-7/16"
Screw Dia.	9-12"	12-14"	12-20"	18-24"	9-12"	12-14"	12-20"	18-24"	12-14"	12-20"	18-24"	12-14"	12-20"	18-24"
D1	1-5/16	1-5/16	1-5/16	1-5/16	1-11/16	1-11/16	1-11/16	1-11/16	1-7/8	1-7/8	1-7/8	2-3/16	2-3/16	2-3/16
D3	21/32	21/32	25/32	29/32	21/32	21/32	25/32	29/32	21/32	25/32	29/32	21/32	25/32	29/32
D4	11.4	11.4	11.4	11.4	11.4	11.4	11.4	11.4	11.4	11.4	11.4	11.4	11.4	11.4
L1	9.00	9.69	9.88	13.13	9.00	9.69	9.88	13.13	9.69	9.88	13.13	9.69	9.88	13.13
L2	3.00	3.00	3.00	4.00	3.00	3.00	3.00	4.00	3.00	3.00	4.00	3.00	3.00	4.00
L3	2.13	2.76	2.87	3.87	2.13	2.76	2.87	3.87	2.76	2.87	3.87	2.76	2.87	3.87
L4	4.00	4.00	4.00	4.00	4.25	4.25	4.25	4.25	5.49	5.49	5.49	6.31	6.31	6.31
L5	6.85	6.85	6.85	6.85	7.99	7.99	7.99	7.99	8.43	8.43	8.43	8.66	8.66	8.66
L6	3.94	3.94	3.94	3.94	4.53	4.53	4.53	4.53	4.96	4.96	4.96	5.71	5.71	5.71
L7	2.91	2.91	2.91	2.91	3.50	3.50	3.50	3.50	3.74	3.74	3.74	4.49	4.49	4.49
L8	23.8	24.5	24.7	27.9	25.8	26.5	26.6	29.9	28.6	28.8	32.0	30.4	30.6	33.8
L10	5.71	5.71	5.71	5.71	5.71	5.71	5.71	5.71	5.71	5.71	5.71	5.71	5.71	5.71
L11	11.1	11.1	11.1	11.1	12.5	12.5	12.5	12.5	14.8	14.8	14.8	19.1	19.1	19.1
L12	16.8	16.8	16.8	16.8	18.2	18.2	18.2	18.2	20.6	20.6	20.6	24.8	24.8	24.8

Note: [1] See view above for Frame Sizes 107C, 115D, 203E, and 207F, 1-1/2" Shaft with 6-9" Screw Diameter.

Sheave Diameters

Minimum Sheave Diameters

To keep the overhung load imposed by the V-Belt on the input shaft within the capacity of the bearings, the minimum pitch diameter of the sheave mounted on the HSM input shaft must comply with the limitation detailed in the tables below.

Unit Size	Ratio	Output Speed RPM	Min. Input Shaft Sheave Pitch Diameter (in.)
107C	5:1	100-109	5.75
		110-139	5.50
		140-280	5.25
		281-390	5.50
		391-400	5.75
	14:1	10-14	2.50
		15-78	2.75
		79-100	3.00
	20:1	10-26	1.75
		27-50	2.00
		51-85	2.25
	25:1	86-100	2.50
10-22		1.50	
23-32		1.75	
115D	5:1	100-119	7.25
		120-209	7.00
		210-230	6.75
		231-330	7.00
		331-390	7.25
	14:1	391-400	7.50
		10-16	3.25
		17-52	3.50
	20:1	53-80	3.75
		81-100	4.00
		10-16	2.25
		17-30	2.50
25:1	31-52	2.75	
	53-80	3.00	
	81-100	3.25	
	10-12	1.75	
	13-24	2.00	
203E	5:1	100-119	8.75
		120-169	8.50
		170-240	8.25
		241-310	8.50
		311-380	8.75
	14:1	381-400	9.00
		10-16	4.00
		17-52	4.25
	20:1	53-78	4.50
		79-100	4.75
		10-24	2.75
		25-30	3.00
25:1	31-52	3.25	
	53-78	3.50	
	79-100	3.75	
	10-20	2.25	
	21-26	2.50	
207F	5:1	100-109	7.00
		110-139	6.75
		140-280	6.50
		281-390	6.75
		391-400	7.00
	14:1	10-50	3.25
		51-78	3.50
		79-85	3.75
	20:1	86-100	4.00
		10-28	2.25
		29-50	2.50
	25:1	51-80	2.75
81-100		3.00	
10-20		1.75	
21-28		2.00	
29-74		2.25	
215G	5:1	75-85	2.50
		86-100	2.75
		100-109	10.00
		110-119	9.75
		120-159	9.50
	14:1	160-270	9.25
		271-350	9.50
		351-400	9.75
	20:1	10-14	4.50
		15-52	4.75
		53-78	5.00
		79-85	5.25
25:1	86-100	5.50	
	10-18	3.00	
	19-26	3.25	
	27-30	3.50	
	31-74	3.75	
215G	5:1	75-85	4.00
		86-100	4.25
		100-109	8.50
		110-126	8.25
		127-339	8.00
	14:1	340-349	7.75
		350-369	7.00
		370-379	6.75
	20:1	380-400	6.50
		10-12	3.75
		13-52	4.00
		53-78	4.25
25:1	79-100	4.50	
	10-12	2.50	
	13-28	2.75	
	29-40	3.00	
	41-78	3.25	
257H	5:1	79-100	3.50
		100-109	8.50
		110-126	8.25
		127-339	8.00
		340-349	7.75
	14:1	350-369	7.00
		370-379	6.75
		380-400	6.50
	20:1	10-12	3.75
		13-52	4.00
		53-78	4.25
		79-100	4.50
25:1	10-12	2.50	
	13-28	2.75	
	29-40	3.00	
	41-78	3.25	
	79-100	3.50	
307H	5:1	10-11	2.00
		12-24	2.25
		25-30	2.50
		31-74	2.75
		75-85	3.00
	14:1	75-85	3.00
		86-100	3.25
		10-11	2.00
	20:1	12-24	2.25
		25-30	2.50
		31-74	2.75
		75-85	3.00
25:1	86-100	3.25	
	10-11	2.00	
	12-24	2.25	
	25-30	2.50	
	31-74	2.75	
315J	5:1	100-109	12.00
		110-119	11.75
		120-159	11.50
		160-259	11.25
		260-289	11.50
	14:1	290-299	11.00
		300-309	10.50
		310-319	10.00
	20:1	320-329	9.75
		330-349	9.00
		350-359	8.50
		360-369	8.25
25:1	370-379	7.75	
	380-400	7.50	
	10-21	5.50	
	22-53	5.75	
	54-79	6.00	
315J	5:1	80-84	6.25
		85-100	6.50
		10-11	3.50
		12-24	3.75
		25-30	4.00
	14:1	31-38	4.25
		39-70	4.50
		71-78	4.75
	20:1	79-85	5.00
		86-100	5.25
		10-20	3.00
		21-24	3.25
25:1	25-28	3.50	
	29-38	3.75	
	39-74	4.00	
	75-78	4.25	
	79-90	4.50	
315J	5:1	91-100	4.75
		100-109	12.25
		110-119	12.00
		120-139	11.75
		140-299	11.50
	14:1	300-309	11.00
		310-319	10.25
		320-329	10.00
	20:1	330-339	9.50
		340-349	9.25
		350-359	8.75
		360-369	8.50
25:1	370-379	8.25	
	380-400	7.75	
	10-14	5.50	
	15-50	5.75	
	51-78	6.00	
315J	5:1	79-80	6.25
		81-90	6.50
		81-90	6.50
		91-100	6.75
		10-14	5.50
	14:1	15-50	5.75
		51-78	6.00
		79-80	6.25
	20:1	81-90	6.50
		91-100	6.75
		10-14	5.50
		15-50	5.75
25:1	51-78	6.00	
	79-80	6.25	
	81-90	6.50	
	91-100	6.75	
	10-14	5.50	
407S	5:1	100-109	12.25
		110-119	12.00
		120-139	11.75
		140-299	11.50
		300-309	11.00
	14:1	310-319	10.25
		320-329	10.00
		330-339	9.50
	20:1	340-349	9.25
		350-359	8.75
		360-369	8.50
		370-379	8.25
25:1	380-400	7.75	
	10-14	5.50	
	15-50	5.75	
	51-78	6.00	
	79-80	6.25	
407S	5:1	81-90	6.50
		91-100	6.75
		10-14	5.50
		15-50	5.75
		51-78	6.00
	14:1	79-80	6.25
		81-90	6.50
		91-100	6.75
	20:1	10-14	5.50
		15-50	5.75
		51-78	6.00
		79-80	6.25
25:1	81-90	6.50	
	91-100	6.75	
	10-14	5.50	
	15-50	5.75	
	51-78	6.00	

Sheave Diameters

Minimum Sheave Diameters (cont.)

Unit Size	Ratio	Output Speed RPM	Min. Input Shaft Sheave Pitch Diameter (in.)
407S (cont.)	20:1	10-22	3.75
		23-28	4.00
		29-32	4.25
		33-70	4.50
		71-78	4.75
		79-85	5.00
		86-100	5.25
	25:1	10-18	3.00
		19-24	3.25
		25-28	3.50
		29-38	3.75
		39-74	4.00
		75-78	4.25
		79-90	4.50
91-100	4.75		
415K	5:1	100-109	15.75
		110-119	15.50
		120-129	15.25
		130-149	15.00
		150-229	14.75
		230-269	14.50
		270-279	13.50
		280-289	13.00
		290-299	12.50
		300-309	12.00
		310-319	11.25
		320-329	11.00
		330-339	10.25
	340-349	10.00	
	14:1	350-369	9.50
		370-379	9.00
		380-400	8.50
		10-14	6.75
		15-26	7.00
		27-37	7.25
38-40		7.00	
41-45	7.25		
46-50	7.00		
51-74	7.25		
75-78	7.50		
79-80	7.75		
81-100	8.00		

Unit Size	Ratio	Output Speed RPM	Min. Input Shaft Sheave Pitch Diameter (in.)
415K (cont.)	20:1	10-12	4.50
		13-24	4.75
		25-28	5.00
		29-32	5.25
		33-50	5.50
		51-78	5.75
		79-80	6.00
	25:1	81-90	6.25
		91-100	6.50
		10-20	4.00
		21-24	4.25
		25-28	4.50
		29-32	4.75
		33-52	5.00
507L	14:1	53-78	5.25
		79-80	5.50
		81-90	5.75
		91-100	6.00
		10-15	9.25
		16-25	9.00
		26-46	8.75
	20:1	47-52	9.00
		53-66	9.25
		67-79	9.50
		80-84	8.75
		85-89	7.50
		90-94	6.50
		95-100	6.00
25:1	10-21	6.25	
	22-26	6.00	
	27-32	6.25	
	33-38	6.50	
	39-46	6.75	
	47-58	7.00	
	59-79	7.25	
	20:1	80-84	6.50
		85-89	5.75
		90-100	4.75
		10-24	5.00
		25-30	5.25
		31-34	5.50
		35-46	5.75
25:1	47-79	6.00	
	80-84	5.25	
	85-89	4.50	
	90-94	4.00	
	95-100	3.50	

Unit Size	Ratio	Output Speed RPM	Min. Input Shaft Sheave Pitch Diameter (in.)	
608M	14:1	10-11	17.50	
		12-15	17.25	
		16-19	17.00	
		20-23	16.75	
		24-27	16.50	
		28-31	16.25	
		32-37	16.00	
		38-42	15.75	
		43-46	16.00	
		47-50	16.25	
	20:1	51-52	16.50	
		53-54	16.75	
		55-70	17.00	
		71-79	17.25	
		80-84	15.00	
		85-89	12.75	
		90-94	11.00	
		95-100	10.00	
		25:1	10-17	11.50
			18-23	11.25
24-28	11.00			
29-30	11.25			
31-34	11.50			
35-42	12.00			
43-50	12.50			
51-62	12.75			
63-79	13.00			
80-84	11.00			
20:1	85-89	9.50		
	90-94	8.00		
	95-100	7.25		
	25:1	10-13	10.00	
		14-24	9.75	
		25-28	10.00	
		29-32	10.25	
		33-34	10.50	
		35-40	10.75	
		41-42	11.00	
43-52		11.25		
53-77		11.50		
78-79		11.25		
20:1	80-84	9.75		
	85-89	8.25		
	90-94	7.00		
	95-100	6.50		

Dimensions – Unit Sizes 107 ~ 307

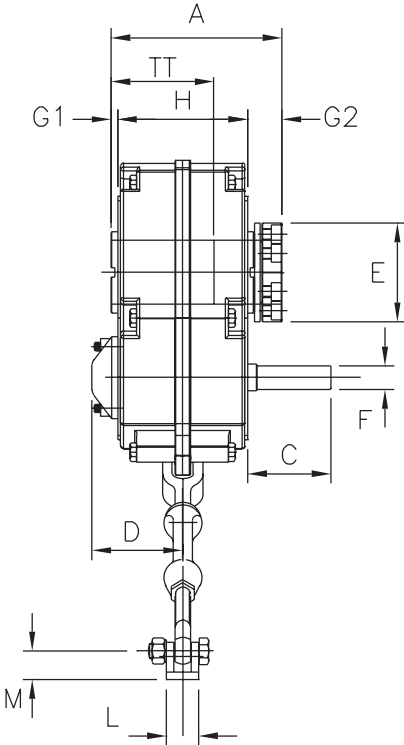
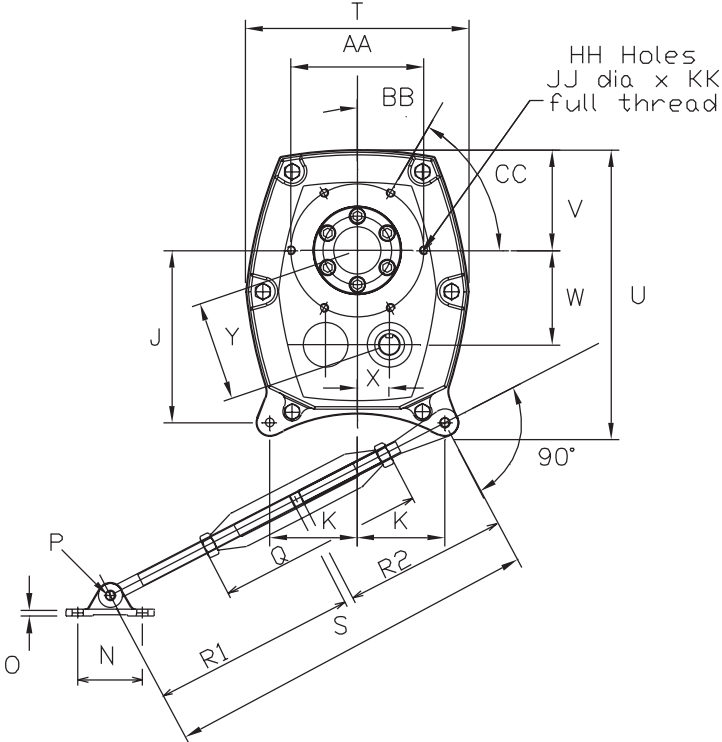

Dimensions – Unit Sizes 107 ~ 307

DIMENSION	UNIT SIZE					
	107C	115D	203E	207F	215G	307H
A	6.38	6.69	7.24	7.91	9.09	10.28
B	Refer to Bore Size table on page 7					
C	2.87	3.23	3.43	3.74	3.94	4.53
D [1]	3.23	3.66	3.74	4.25	4.49	5.00
E	3.23	3.62	4.09	4.49	5.43	5.98
F (key)	Ø3/4 (3/16 x 3/16)	Ø15/16 (1/4 x 1/4)	Ø1-1/16 (1/4 x 1/4)	Ø1-1/8 (1/4 x 1/4)	Ø1-5/16 (5/16 x 5/16)	Ø1-11/16 (3/8 x 3/8)
G1	0.16	0.16	0.16	0.28	0.28	0.28
G2	1.46	1.42	1.65	1.54	1.97	2.01
H	4.65	5.00	5.31	6.10	6.85	7.99
J	5.45	6.65	7.91	9.35	10.28	11.57
K	3.01	3.31	4.02	4.76	5.24	5.98
L	0.94	1.34	1.34	1.65	1.65	2.76
M	0.79	0.94	0.94	1.26	1.26	1.97
N	2.56	2.95	2.95	3.94	3.94	4.72
O	0.20	0.31	0.31	0.47	0.47	0.71
P	0.39	0.51	0.51	0.67	0.67	0.63
Q	7.87	8.50	8.50	8.50	8.50	8.74
R1	11.8	13.8	13.8	14.8	14.8	14.8
R2	6.57	7.44	7.44	9.69	9.69	10.4
S	Min.	18.4	21.2	21.2	24.4	25.1
	Max.	24.3	27.1	27.1	30.4	31.0
T	7.32	8.58	10.16	10.9	12.5	14.4
U	9.21	11.10	12.99	15.2	16.6	18.8
V	3.19	3.78	4.61	5.08	5.63	6.38
W	2.95	3.54	4.33	4.94	5.55	6.14
X	1.00	1.22	1.46	1.71	1.96	2.20
Y	3.11	3.74	4.57	5.24	5.88	6.54
AA	4.72	5.31	6.10	6.89	8.35	10.04
BB	45°	45°	30°	30°	30°	0°
CC	90°	90°	60°	60°	60°	60°
HH	4	4	6	6	6	5
JJ	M10	M10	M10	M12	M16	M20
KK	0.59	0.59	0.59	0.71	0.83	0.98
TT	2.9	3.2	3.6	3.8	4.4	4.9
Single Red. Wt. (lbs)	30.9	48.5	68.4	99.2	141.1	220.5
Double Red. Wt. (lbs)	33.1	52.9	75.0	108.0	152.1	238.1

Note: [1] Dimension D is increased by 0.28 inches when a backstop is fitted.

Exact Ratio

Nominal Ratio	Unit Size					
	107C	115D	203E	207F	215G	307H
5:1	4.941	5.050	5.047	5.047	5.047	5.047
14:1	13.410	13.596	13.587	13.587	13.395	13.587
20:1	20.421	20.466	20.455	20.455	20.455	20.455
25:1	23.544	25.250	25.235	25.235	25.235	25.235

Dimensions shown are for reference only and are subject to change without notice, unless certified.
Certified prints are available after receipt of an order; consult factory.

Dimensions – Unit Sizes 315 ~ 608

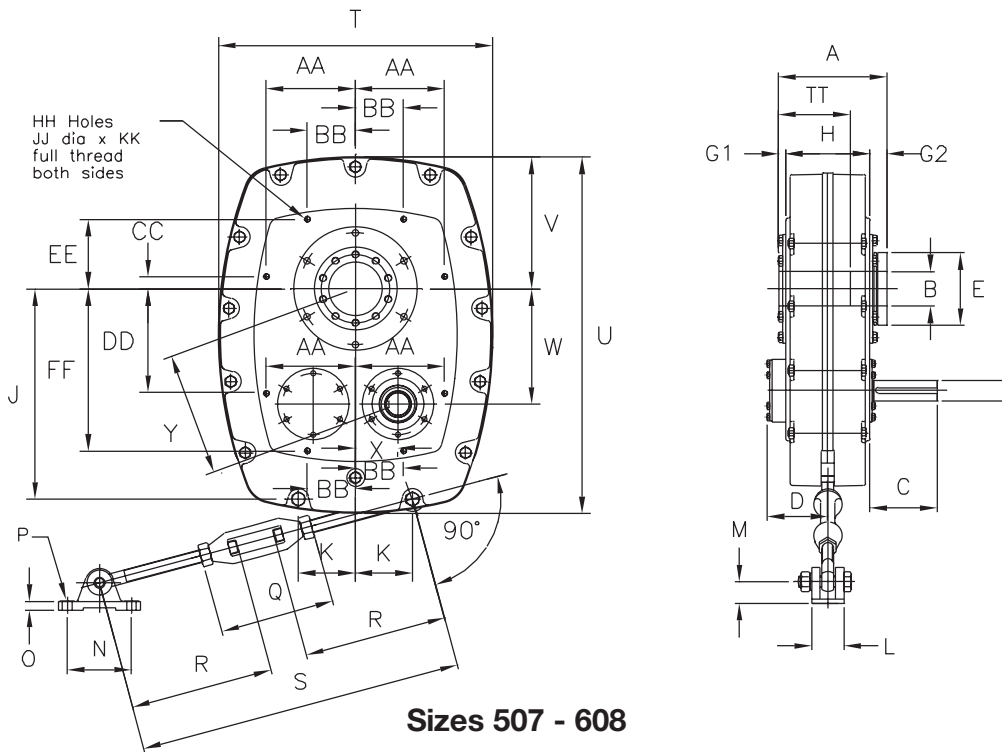
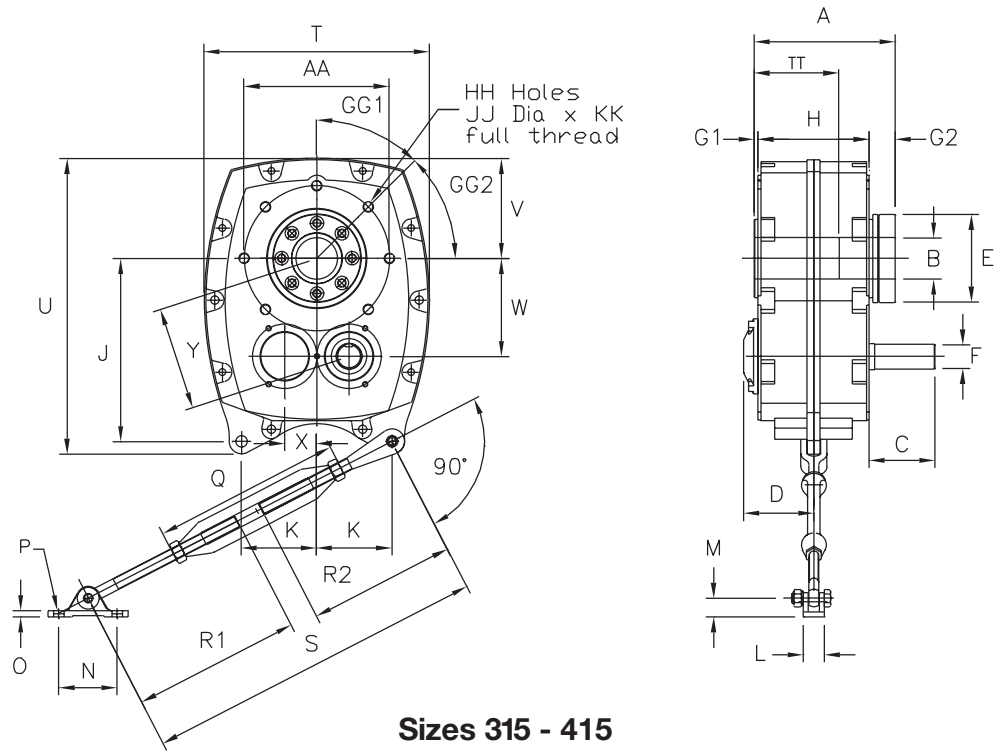

Dimensions – Unit Sizes 315 ~ 608

DIMENSION	UNIT SIZE				
	315J	407S	415K	507L	608M
A	10.7	10.9	11.4	14.0	16.0
B	Refer to Bore Size table on page 7				
C	4.96	5.71	7.09	8.50	9.49
D [1]	5.24	5.28	5.55	7.99	8.86
E	6.69	7.32	8.15	9.37	10.9
F (key)	Ø1-7/8 (1/2 x 1/2)	Ø2-3/16 (1/2 x 1/2)	Ø2-7/16 (5/8 x 5/8)	Ø2-9/16 (5/8 x 5/8)	Ø3-3/8 (7/8 x 7/8)
G1	0.26	0.28	0.30	0.87	0.87
G2	1.97	2.01	2.32	2.17	2.17
H	8.46	8.66	8.82	10.6	12.5
J	13.9	18.0	20.4	23.2	26.7
K	5.71	6.18	6.30	6.30	7.48
L	2.76	2.76	2.76	4.33	4.33
M	1.97	1.97	1.97	2.99	2.99
N	4.72	4.72	4.72	7.09	7.09
O	0.71	0.71	0.71	1.02	1.02
P	0.63	0.63	0.63	M24	M24
Q	8.74	8.74	8.74	10.4	10.4
R	–	–	–	15.7	15.7
R1	14.8	14.8	14.8	–	–
R2	10.4	10.4	10.4	–	–
S	Min.	25.1	25.1	31.5	31.5
	Max.	31.0	31.0	31.0	37.4
T	17.1	21.3	22.4	30.3	34.6
U	22.4	28.9	32.0	39.4	44.9
V	7.68	10.0	11.1	14.6	16.1
W	7.44	10.0	10.5	12.8	14.7
X	2.44	2.95	3.67	4.69	5.24
Y	7.87	10.5	11.1	13.6	15.6
AA	11.0	11.0	12.60	9.84	12.4
BB	–	–	–	5.31	5.12
CC	–	–	–	1.34	-1.57
DD	–	–	–	11.6	11.0
EE	–	–	–	7.68	8.46
FF	–	–	–	17.9	21.1
GG1	0°	22.5°	22.5°	–	–
GG2	45°	45°	45°	–	–
HH	7	8	8	8	8
JJ	M20	M20	M20	M16	M16
KK	0.94	1.18	0.94	1.06	1.06
TT	5.62	5.12	5.24	6.50	7.40
Single Red. Wt. (lbs)	324	443	567	–	–
Double Red. Wt. (lbs)	342	483	622	1202	1632

Note: [1] Dimension D is increased by 0.28 inches when a backstop is fitted.

Exact Ratio

Nominal Ratio	Unit Size				
	315J	407S	415K	507L	608M
5:1	5.047	5.047	4.684	–	–
14:1	13.587	13.587	13.644	13.260	12.850
20:1	20.455	20.455	20.113	19.580	19.330
25:1	25.235	25.235	23.655	24.733	22.601

Dimensions shown are for reference only and are subject to change without notice, unless certified.
Certified prints are available after receipt of an order; consult factory.

Motor Mounts

The Sumitomo motor mounting assembly provides a rigid baseplate that is designed to accommodate a wide range of motor frame sizes. Each size of motor mount has sufficient adjustment available to insure that a standard

belt can be fitted and re-tensioned as required through its working life. Refer to the Belt Guard Dimensions page for additional information.

Sizes 107C – 415K

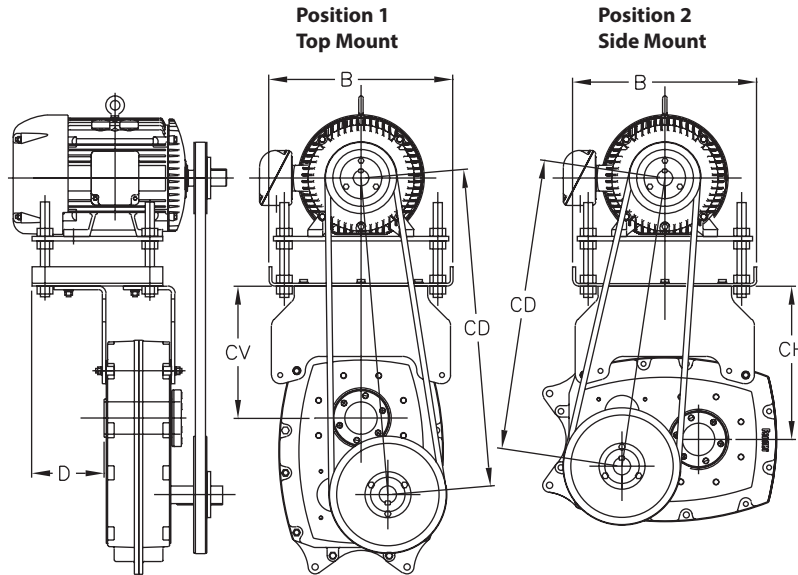

Sizes 507L – 608M

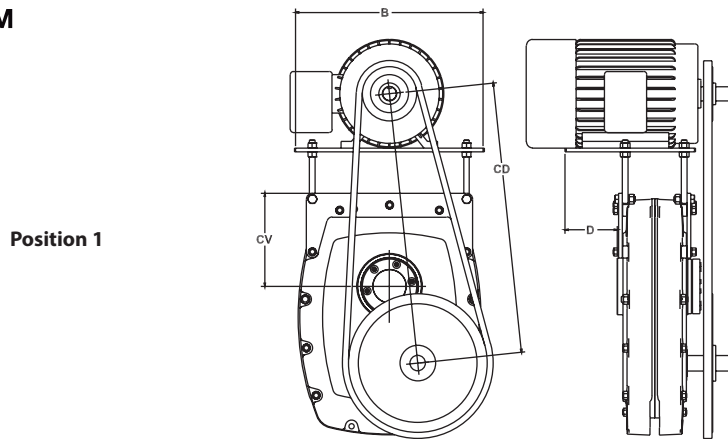

Dimensions (Inch)

Model	NEMA Frame Size	CD TOP MOUNT		CD SIDE MOUNT		B	CV	CH	D Max.	Weight (lb)
		Min.	Max.	Min.	Max.					
107C	56~184T	16.75	21.00	15.25	19.00	13.62	7.87	8.15	5.40	40
115D	56~215T	17.75	23.00	16.50	21.25	14.63	8.62	9.25	6.38	52
203E	56~215T	20.50	25.50	18.50	23.00	14.63	10.31	11.02	5.86	55
207F	56~215T	22.25	27.25	20.00	24.75	14.63	11.36	12.20	4.76	56
215G	143T~286T	24.50	32.00	22.00	29.25	18.62	12.40	13.31	11.07	130
307H	143T~286T	25.00	32.25	22.25	29.50	18.62	12.09	13.31	9.33	129
315J	143T~326T	27.75	36.00	24.00	32.25	20.50	13.50	14.65	10.57	144
407S	143T~326T	30.75	39.00	25.00	33.25	20.50	13.94	14.80	9.61	138
415K	213T~365T	38.25	47.75	34.50	44.00	25.20	18.09	21.02	11.95	265
507L	254T~405T	39.00	44.50	-	-	31.50	28.19	-	14.86	206
608M	254T~445T	43.00	48.50	-	-	33.07	31.54	-	18.01	239

Dimensions shown are for reference only and are subject to change without notice, unless certified. Certified prints are available after receipt of an order; consult factory.

Extended Motor Mounts

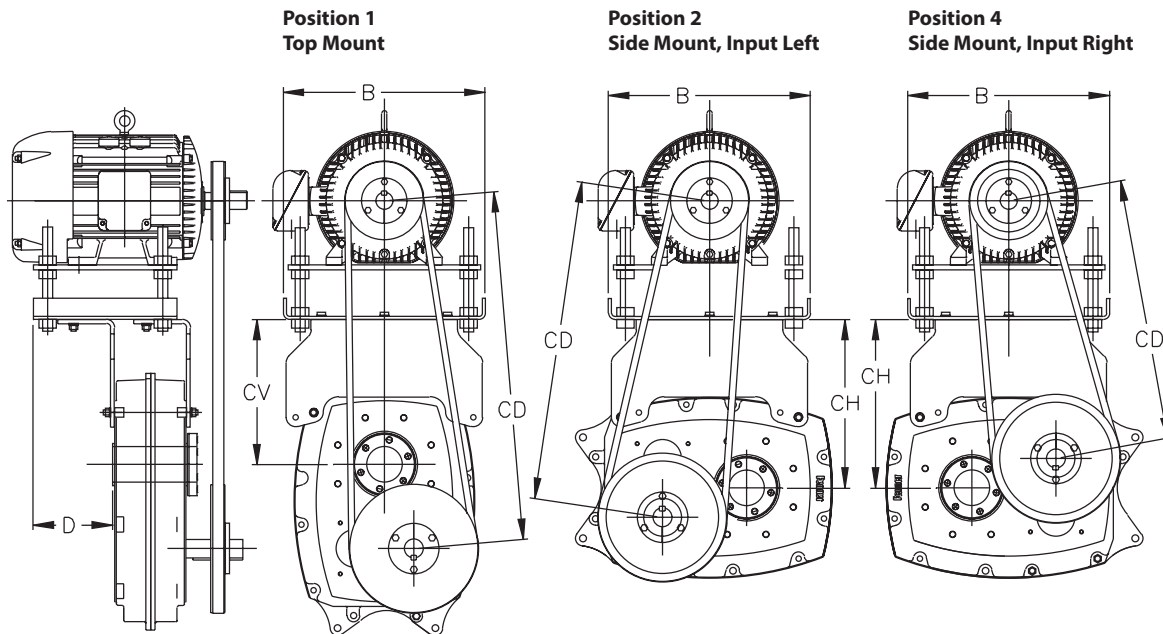

Extended Motor Top-Mounted for use with CEMA Screw Conveyor Drive Option

Dimensions (in)

Model	NEMA Frame Size	CD TOP MOUNT		CD SIDE MOUNT Input On Left		CD SIDE MOUNT Input On Right		B	CV	CH	D Max	Weight (lb)
		Min.	Max.	Min.	Max.	Min.	Max.					
107C	56~184T	24.6	29.6	23.3	28.4	21.3	26.4	13.62	16.14	16.81	5.40	57
115D	56~215T	25.1	31.1	23.5	29.5	21.1	27.0	14.62	16.10	16.73	6.38	70
203E	56~215T	26.4	32.4	24.4	30.3	21.5	27.4	14.62	16.61	17.33	5.86	70
207F	56~215T	26.9	32.9	24.6	30.6	21.2	27.2	14.62	16.48	17.32	4.76	70
215G	143T~286T	31.6	40.1	29.0	37.5	25.1	33.6	18.62	19.88	20.79	11.07	158
307H	143T~286T	32.3	40.8	29.8	38.3	25.5	33.9	18.62	19.96	21.38	9.33	165
315J	143T~326T	33.4	42.9	29.8	39.2	25.0	34.4	20.50	19.80	20.94	10.57	177
407S	143T~326T	36.1	45.6	30.4	39.7	24.6	33.9	20.50	19.84	20.71	9.61	169

Dimensions shown are for reference only and are subject to change without notice, unless certified.
 Certified prints are available after receipt of an order; consult factory.

Belt Guards Dimensions

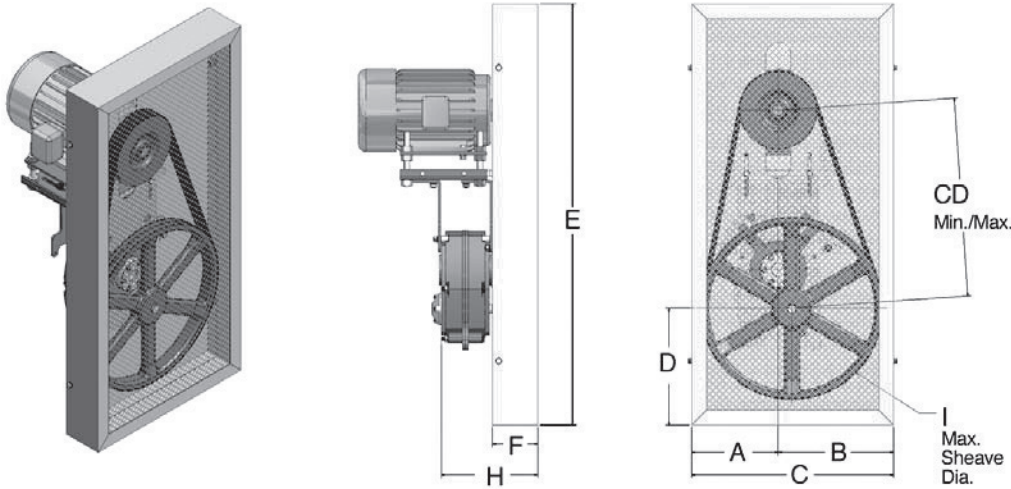

Top Mount Reducer

Unit Size	107C	115D	203E	207F	215G	307H	315J	407S	415K
Belt Guard Part No.	116C6061	116D6061	116E6061	116F6061	116G6061	116H6061	116J6061	116S6061	116K6061
A	7.3	11.0	11.0	11.0	12.0	12.0	12.0	12.0	12.0
B	9.7	14.5	14.5	14.5	18.0	18.0	18.0	18.0	18.0
C	17.0	25.5	25.5	25.5	30.0	30.0	30.0	30.0	30.0
D	9.5	15.9	15.0	14.5	19.2	18.6	17.3	14.8	14.3
E	40.0	53.0	53.0	53.0	61.0	61.0	61.0	61.0	71.0
F	5.0	6.0	6.0	6.0	8.0	8.0	8.0	8.0	9.0
H	10.0	10.9	11.6	12.4	15.2	16.4	16.8	17.0	18.3
I Max ^[1]	14.0	23.0	23.0	23.0	27.0	27.0	27.0	27.0	27.0
CD MIN	16.8	17.8	20.5	22.3	24.5	25.0	27.8	30.8	38.3
CD MAX	21.0	23.0	25.5	27.3	32.0	32.3	36.0	39.0	47.8

Side Mount Reducer

Unit Size	107C	115D	203E	207F	215G	307H	315J	407S	415K
Belt Guard Part No.	116C6161	116D6161	116E6161	116F6161	116G6161	116H6161	116J6161	116S6161	116K6161
A	10.3	16.5	16.5	16.5	20.7	20.7	20.7	20.7	20.7
B	7.7	13.5	13.5	13.5	10.0	10.0	10.0	10.0	10.0
C	18.0	30.0	30.0	30.0	30.7	30.7	30.7	30.7	30.7
D	9.7	13.2	13.1	12.9	15.3	15.0	14.8	14.3	13.6
E	40.0	48.0	48.0	48.0	56.0	56.0	56.0	56.0	65.0
F	5.0	6.0	6.0	6.0	8.0	8.0	8.0	8.0	9.0
H	10.0	10.9	11.6	12.4	15.2	16.4	16.8	17.0	18.3
I Max ^[1]	14.0	23.0	23.0	23.0	27.0	27.0	27.0	27.0	27.0
CD MIN	15.3	16.5	18.5	20.0	22.0	22.3	24.0	25.0	34.5
CD MAX	19.0	21.3	23.0	24.8	29.3	29.5	32.3	33.3	44.0

Note: [1] The belt guard should be selected based on the maximum sheave diameter (I Max) that will be used in the application.

Dimensions shown are for reference only and are subject to change without notice, unless certified.
Certified prints are available after receipt of an order; consult factory.

Dimensions Extended Belt Guards

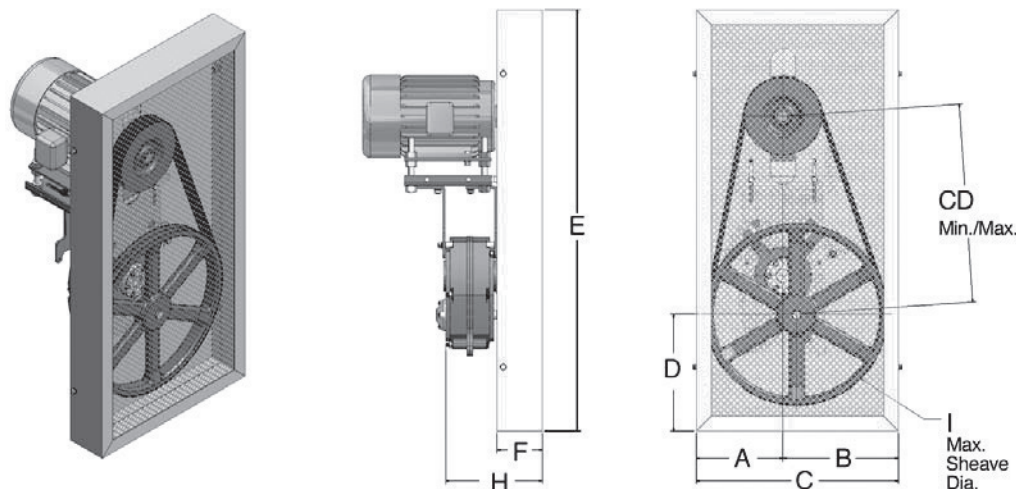

Top Mount Reducer, CEMA Screw Conveyor Extended Belt Guard

Unit Size	107C	115D	203E	207F	215G	307H	315J	407S
Belt Guard Part No.	116C6061-X	116D6061-X	116E6061-X	116F6061-X	116G6061-X	116H6061-X	116J6061-X	116S6061-X
A	8.5	11.3	11.3	11.3	13.2	13.2	12.2	12.2
B	8.5	14.2	14.2	14.2	16.8	16.8	17.8	17.8
C	17.0	25.5	25.5	25.5	30.0	30.0	30.0	30.0
D	7.8	13.9	13.1	12.5	19.4	18.8	17.5	14.9
E	41.3	53.0	53.0	53.0	68.4	68.4	68.4	68.4
F	5.0	6.0	6.0	6.0	8.0	8.0	8.0	8.0
H	10.0	11.3	11.5	12.4	15.3	16.4	16.9	17.1
I Max ^[1]	13.0	23.0	23.0	23.0	27.0	27.0	27.0	27.0
CD MIN	24.6	25.1	26.4	26.9	31.6	32.3	33.4	36.1
CD MAX	29.6	31.1	32.4	32.9	40.1	40.8	42.9	45.6

Side Mount Reducer, CEMA Screw Conveyor Extended Belt Guard

Unit Size	107C	115D	203E	207F	215G	307H	315J	407S
Belt Guard Part No.	116C6161-X	116D6161-X	116E6161-X	116F6161-X	116G6161-X	116H6161-X	116J6161-X	116S6161-X
AL	10.3	16.6	16.9	17.4	20.0	20.4	23.7	24.3
AR	7.7	13.4	13.1	12.6	15.0	14.6	17.3	16.6
BL	7.7	13.4	13.1	12.6	15.0	14.6	17.3	16.6
BR	10.3	16.6	16.9	17.4	20.0	20.4	23.7	24.3
C	18.0	30.0	30.0	30.0	35.0	35.0	40.9	40.9
DL	7.4	12.6	12.3	12.2	14.5	14.3	14.8	14.3
DR	9.4	15.2	15.2	15.6	18.5	18.7	19.7	20.2
E	40.0	48.0	48.0	48.0	58.3	58.3	60.2	60.2
F	5.0	6.0	6.0	6.0	8.0	8.0	8.0	8.0
H	10.0	11.4	11.6	12.5	15.3	16.4	16.9	17.1
I Max ^[1]	13.0	23.0	23.0	23.0	27.0	27.0	27.0	27.0
CD ^L MIN	23.3	23.5	24.4	24.6	29.0	29.8	29.8	30.4
CD ^R MIN	21.3	21.1	21.5	21.2	25.1	25.5	25.0	24.6
CD ^L MAX	28.4	29.5	30.3	30.6	37.5	38.3	39.2	39.7
CD ^R MAX	26.4	27.0	27.4	27.2	33.6	33.9	34.4	33.9

Notes:

[1] The belt guard should be selected based on the maximum sheave diameter (I Max) that will be used in the application.

[L] Input Shaft on left side.

[R] Input Shaft on right side.

Dimensions shown are for reference only and are subject to change without notice, unless certified.
Certified prints are available after receipt of an order; consult factory.

Installation

Gearbox Installation

Satisfactory performance depends on proper installation, lubrication and maintenance. Therefore it is important that the instructions in the Installation and Maintenance leaflet, supplied with each gearbox, are followed carefully. Some of the important aspects of belt and torque-arm installation are listed below.

Install pulley on gearbox input shaft as close to the reducer as

possible. See Fig 1. Failure to do this will cause excess loads in the input shaft bearings and could cause their premature failure.

Install motor and belt drive with the belt pull at approximately 90° to the center line between driven and input shafts. See Fig 2. This will permit tensioning of the belt drive with the torque arm, which must be in tension. If output hubs runs counter-clockwise,

torque arm must be positioned to the right. See Fig 3.

Install torque-arm on a rigid support so that the torque arm will be at approximately right angles to the center line through the driven shaft and the torque-arm case bolt. See Fig 4. Make sure there is sufficient take-up in the turn-buckle for belt tension adjustment.

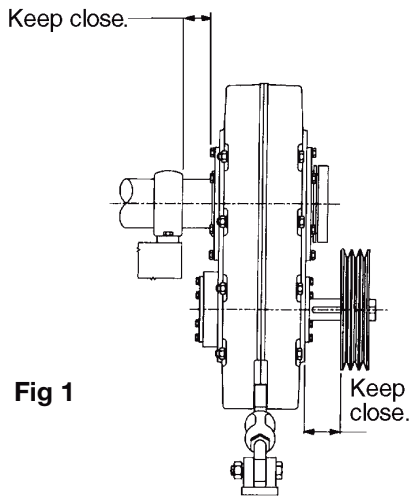

Fig 1

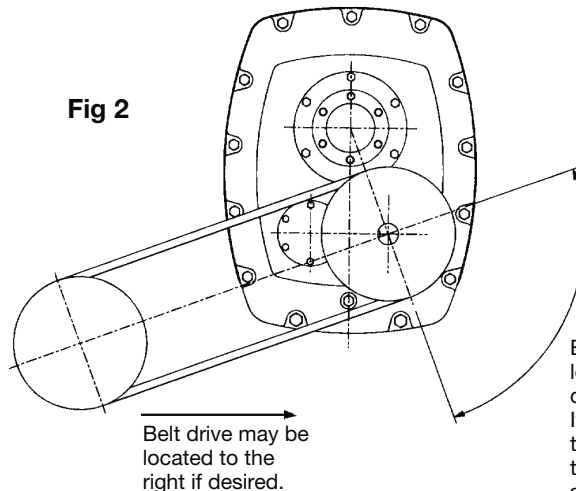

Fig 2

Belt drive may be located in any convenient position. If the Torque arm is to be used to tighten the belts, the drive should be at about 90° to line between the Input and Output Shafts.

If output hub rotates clockwise, position Belt drive and Torque arm in opposite direction to that shown in the illustration.

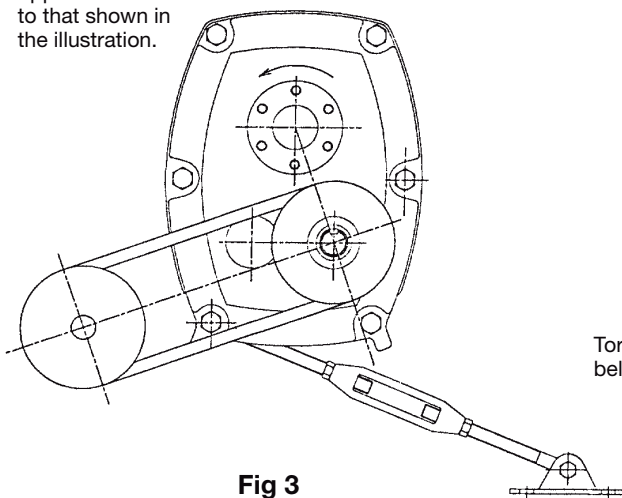
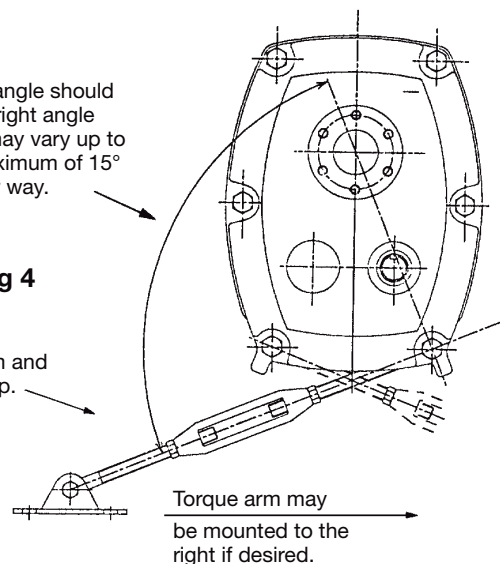

Fig 3

This angle should be a right angle but may vary up to a maximum of 15° either way.

Torque arm and belt take up.

Fig 4



Torque arm may be mounted to the right if desired.

Approximate Oil Quantity (gallons) Required

Ratio	Mounting Position	HSM Reducer Size										
		HSM107C	HSM115D	HSM203E	HSM207F	HSM215G	HSM307H	HSM315J	HSM407S	HSM415K	HSM507L	HSM608M
5:1	1	0.13	.21	.32	0.66	.87	1.08	1.51	2.88	4.02	-	-
	2	0.13	.24	.45	0.69	.85	1.40	2.27	4.86	5.73	-	-
	3	0.13	.21	.37	0.63	.85	1.08	1.56	3.59	6.66	-	-
	4	0.16	.26	.48	0.66	.87	1.53	2.27	4.86	5.47	-	-
9:1, 14:1, 20:1, 25:1	1	0.11	.18	.26	0.61	.79	1.00	1.43	2.40	3.36	5.94	9.51
	2	0.16	.24	.48	0.69	.85	1.45	2.25	4.33	5.73	9.11	13.2
	3	0.13	.21	.37	0.63	.85	1.11	1.56	3.33	4.15	13.70	20.9
	4	0.16	.24	.42	0.58	.85	1.35	2.19	4.07	5.07	7.13	11.9

Recommended Lubricants

Mineral Oil ISO Grade for Ambient Temperatures between 81°F to 105°F

Ratio	Output RPM	HSM Reducer Size										
		HSM107C	HSM115D	HSM203E	HSM207F	HSM215G	HSM307H	HSM315J	HSM407S	HSM415K	HSM507L	HSM608M
5:1	201 - 400	680	460	460	460	460	460	460	460	-	-	-
	101 - 200	680	680	680	680	680	680	680	680	-	-	-
	0 - 100	800	800	800	800	800	800	800	800	800	-	-
9:1, 14:1, 20:1, 25:1	51 - 120	680	680	460	460	460	460	460	460	-	-	-
	21 - 50	800	800	800	800	800	800	800	800	-	-	-
	0 - 20	800	800	800	800	800	800	800	800	-	-	-
14:1, 20:1, 25:1	51 - 80	-	-	-	-	-	-	-	-	320	320	320
	0 - 50	-	-	-	-	-	-	-	-	460	460	460

Mineral Oil ISO Grade for Ambient Temperatures between 41°F to 80°F

Ratio	Output RPM	HSM Reducer Size										
		HSM107C	HSM115D	HSM203E	HSM207F	HSM215G	HSM307H	HSM315J	HSM407S	HSM415K	HSM507L	HSM608M
5:1	201 - 400	320	220	220	220	220	220	220	220	-	-	-
	101 - 200	320	320	320	320	320	320	320	320	-	-	-
	0 - 100	460	460	460	460	460	460	460	460	-	-	-
9:1, 14:1, 20:1, 25:1	51 - 120	460	460	320	320	320	320	320	320	-	-	-
	21 - 50	680	680	460	460	460	460	460	460	-	-	-
	0 - 20	680	680	680	680	680	680	680	680	-	-	-
14:1, 20:1, 25:1	51 - 80	-	-	-	-	-	-	-	-	220	220	220
	0 - 50	-	-	-	-	-	-	-	-	320	320	320

Mineral Oil ISO Grade for Ambient Temperatures between 14°F to 40°F

Ratio	Output RPM	HSM Reducer Size										
		HSM107C	HSM115D	HSM203E	HSM207F	HSM215G	HSM307H	HSM315J	HSM407S	HSM415K	HSM507L	HSM608M
5:1	201 - 400	100	68	68	68	68	68	68	68	-	-	-
	101 - 200	100	100	100	100	100	100	100	100	-	-	-
	0 - 100	100	100	100	100	100	100	100	100	-	-	-
9:1, 14:1, 20:1, 25:1	51 - 120	100	100	100	100	100	100	100	100	-	-	-
	21 - 50	150	150	150	150	150	150	150	150	-	-	-
	0 - 20	150	150	150	150	150	150	150	150	-	-	-
14:1, 20:1, 25:1	51 - 80	-	-	-	-	-	-	-	-	100	100	100
	0 - 50	-	-	-	-	-	-	-	-	100	100	100

Table 6. Manufacturers and Types

BP ENERGOL GR-XP	CASTROL ALPHA ZN or SP	MOBIL SEE LUBRICATION SECTION	SHELL OMALA S2 G	TEXACO MEROPA	EXXON SPARTAN
------------------------	------------------------------	-------------------------------------	------------------------	------------------	------------------

Note: Do not use E.P. mineral oils other than those recommended when using a backstop.

Table 1. Taper-Grip® Bushing Screw Torques

SM-Shaft Mount Size	Original Taper-Grip® Bushing Screw Torque		New STEEL Taper-Grip® Bushing Screw Torque	
	Nm	lb. ft.	Nm	lb. ft.
107C	31	23	50	37
115D	31	23	55	41
203E	51	37.5	75	56
207F	51	37.5	140	104
215G	128	94	250	185
307H	245	180	250	185
315J	245	180	250	185
407S	245	180	250	185
415K	245	180	300	223
507L	245	180	300	223
608M	245	180	330	223

Taper-Grip Bushing®

Table 2. Shaft Tolerances

Shaft Dia.	Tolerance
3/4 - 1 1/8	+0 ⁻ - 0.0013"
1 3/16 - 2	+0 ⁻ - 0.0015"
2 1/16 - 3 1/8	+0 ⁻ - 0.0018"
3 3/16 - 4 3/4	+0 ⁻ - 0.0021"
4 13/16 - 6 1/2	+0 ⁻ - 0.0025"

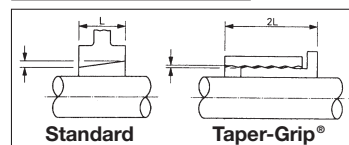

Lubrication

HSM Shaft Mount Speed Reducers are shipped **without oil**. Before running they should be filled with an appropriate amount of the correct lubricant as shown in the tables.

For reducers without backstops, Sumitomo recommends:

Mobil Mobilgear 600 XP series mineral oil. If ISO Grade 800 is recommended, but unavailable, use ISO Grade 680.

Mobil Mobilgear SHC XMP synthetic oil, ISO Grade 320, is suitable for all ambient temperatures and all output speeds.

For reducers with backstops, Sumitomo recommends:

HSM107C & HSM115D Mobil SHC 600 Series synthetic oil, ISO Grade 320, is suitable for all ambient temperatures and all output speeds.

Caution: Do not use E.P. oils to lubricate HSM107C & HSM115D units having backstops.

HSM203E - HSM608M

Mobil Mobilgear 600 XP series mineral oil. If ISO Grade 800 is recommended, but unavailable, use ISO Grade 680.

Mobil Mobilgear SHC XMP synthetic oil, ISO Grade 320, is suitable for all ambient temperatures and all output speeds.

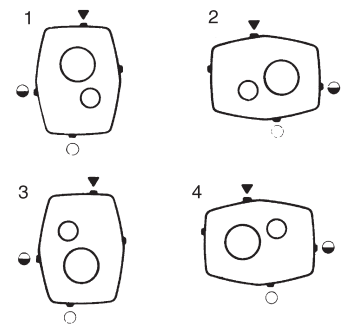

▼ Filter plug ● Level plug ○ Drain plug

Units are fitted with filter, level and drain plugs generally in the position shown.

Warranty

Company warrants that (i) all new equipment and parts (collectively, "Equipment") sold by Company will conform to printed drawings and specification sheets issued by Company and (ii) are free of defects in material and workmanship for the time period shown in Table below. The warranty period commences on the date of shipment of the Equipment by Company.

If, within the warranty period, Company receives from Buyer written notice of any alleged defect in any of the Equipment and, if the Equipment is found by Company not to conform with these warranties (after Buyer has provided Company a reasonable opportunity to perform any appropriate tests on the allegedly defective Equipment), Company will, at its sole option and expense, either repair or replace the Equipment. In all instances, Company reserves the right to require Buyer to deliver the Equipment for repair or replacement to a designated service center and require Buyer to pay all charges for inbound and outbound transportation and for services of any kind, diagnostic or otherwise, excepting only the direct and actual cost of Equipment repair or replacement. Warranty coverage is limited to parts and labor and does not include travel and other expenses. Buyer applications and use of the Equipment may require installation of safety features. Buyer is responsible for furnishing and installing guards or other safety equipment needed to protect operating personnel, even though such equipment may not be furnished by Company with the Equipment purchased. Equipment supplied, but not manufactured, by Company is warranted only to the extent of the original manufacturer's warranty.

Product Warranty

Product	Warranty Period (After Shipment)	Components Excluded
Cyclo® Speed Reducers and Gearmotors	3 Years	Wearable items
Cyclo® Bevel & Helical BuddyBox® Speed Reducers and Gearmotors	3 Years	Wearable items
Fine Cyclo® and Elastic Cyclo (ECY) Speed Reducers	1 Year	Wearable items
Beier® Variator Mechanical Adjustable Speed Reducers	2 Years	Wearable items
Hyponic® Speed Reducers and Gearmotors	3 Years	Wearable items
Helical Shaft Mount Speed Reducers	3 Years	Wearable items
Bevel BuddyBox® H Series Speed Reducers and Gearmotors	3 Years	Wearable items
Fortress® Speed Reducers	3 Years	Wearable items
Rhytax® Speed Reducers and Gearmotors	3 Years	Wearable items
IB Series Servo Gearheads & Astero Gearmotors	1 Year	Wearable items
Motors	1 Year	-
Variable Frequency Drives (Invertek)	3 Years	-
Hedcon® Double Enveloping Worm Gear Speed Reducers	2 Years	Wearable items
Paramax® Right Angle Spiral Bevel Gear and Parallel Shaft Helical Gear Speed Reducers	2 Years	Wearable items
Hansen UniMiner and P4 Right Angle Spiral Bevel Gear and Parallel Shaft Helical Gear Speed Reducers	2 Years	Wearable items
Paramax® and Hansen Cooling Tower Application Series Speed Reducers	1 Year	Wearable items
Compower® Planetary Speed Reducers	1 Year	Wearable items
Parts	1 Year	-
Repairs	1 Year	Wearable items

Notes

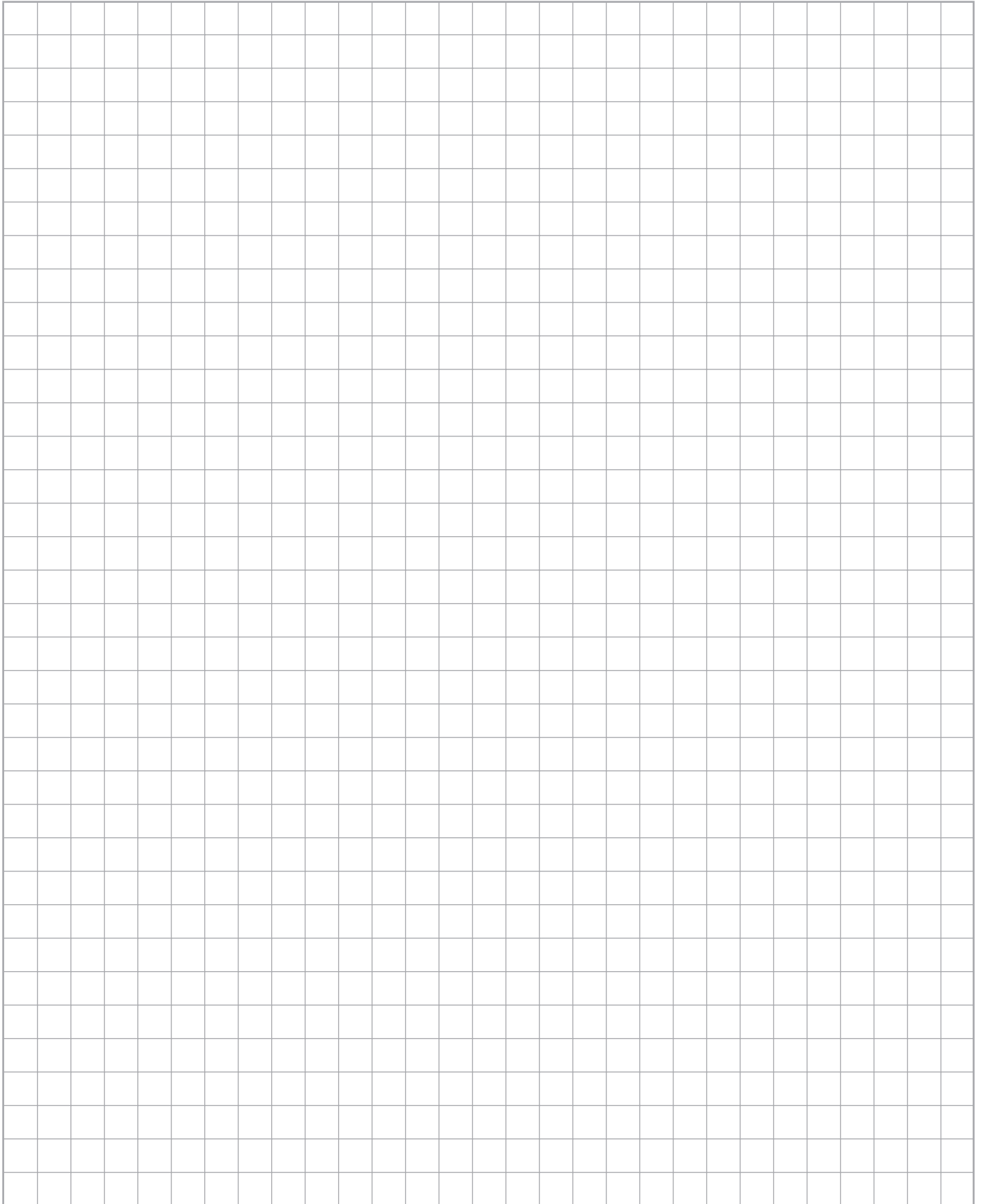

Notes

