

A global power transmission solutions provider, with facilities strategically located throughout the world, providing comprehensive products and services in your region.

LARGE INDUSTRIAL GEARBOXES

HEADQUARTERS



4200 Holland Blvd
Chesapeake, VA 23323

Email: SMA.CustomerService@shi-g.com
Phone: 757-485-3355

- ★ MANUFACTURING HUB & HEADQUARTERS
- ★ MANUFACTURING HUB
- ASSEMBLY & SERVICE
- SERVICE
- ▲ REGIONAL SALES OFFICE

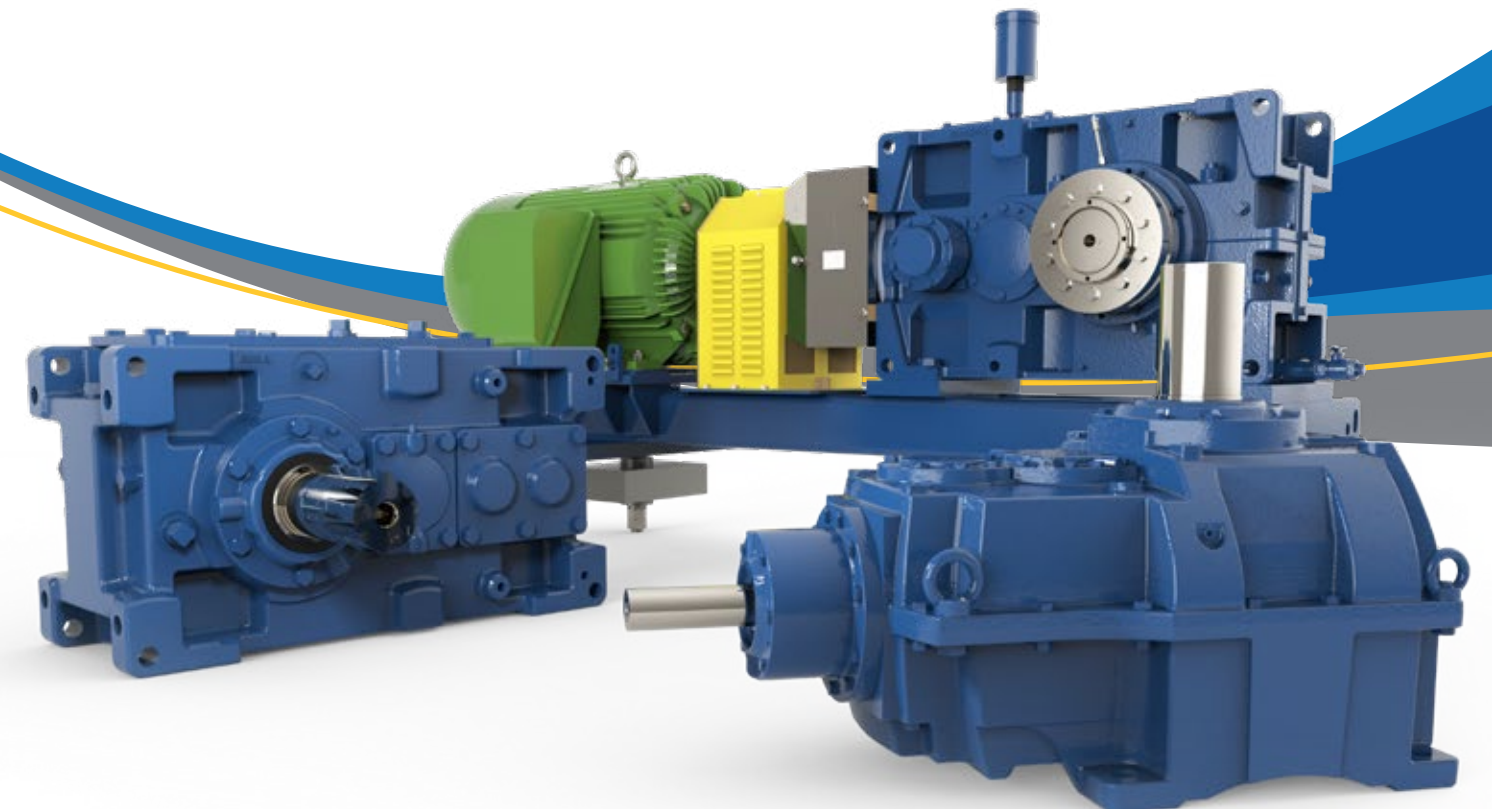

The widest range of standard catalogued large industrial gearboxes on the market.

A purpose-built facility for all of your large industrial gearbox needs.

SERIOUSLY LARGE GEARBOXES

Paramax® offers a **rugged, flexible, economical** option with a **robust, proven** design. This allows for **quick** shipments, with a **wide range** of options for a **reasonable price**.

Hansen products offer an **engineered solution** to meet your applications most demanding needs. Hansen vertical gearboxes incorporate the **best features** that long-running and heavy-duty applications require.

THE SUMITOMO DRIVE TECHNOLOGIES STANDARD

We ask the **right questions** to ensure you have the **correct** industrial gearbox for your **specific** application. **Customer experience** is our top **priority**, and we want to ensure that our customers can get the modifications or custom options they desire.

Our Paramax® and Hansen brands offer the **widest range of large industrial gearboxes** on the market. Historically, we have supplied products that have **outperformed our competition** in the toughest of industries, such as **forestry, steel, and mining**.

With a **reduced** average lead time, **sizeable** domestic inventory and a staff of **specialized** engineers and manufacturers, customers are able to select from a wide range of products and options to solve their **toughest problems**.

THE RIGHT GEARBOX FOR THE RIGHT JOB

We are interested in selling the **right gearbox for the application**—not just any gearbox in our inventory. Sumitomo Drive Technologies has the products that perform.

Standard large industrial gearboxes are **pre-engineered** and **manufactured** to be assembled from **our inventory**. **Local** engineering, manufacturing, and assembly allow us to customize these products to meet your needs.

Our large industrial gearboxes also have various **upgrades** and **performance monitoring products** to keep each gearbox in action. By following our preventative maintenance procedures, you ensure your gearbox lives a long life. If your gearbox has an issue, our **experienced network of aftermarket experts** are **always available**. Plus, with a factory warranty, your operation is **well protected**.

VERONA FACILITY

Our **industrial gearbox facility** is tucked along the industrial corridor of I-81 in the picturesque Shenandoah Valley of Virginia. This **purpose-built** facility was **designed** to efficiently handle the **inventory, machining, assembly, quality control, and testing** for our entire line of industrial gearboxes in the **United States**.



CUSTOM

Purpose-Built Facility

Optimized to build over **100** large industrial gearboxes a month. There's little we can't handle.



MACHINING

On-Site Machining Capabilities

With a **full-service machine shop** at our disposal, we keep costs and lead times down.

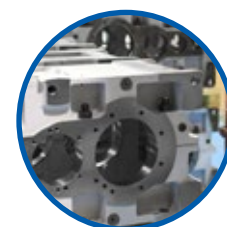

INVENTORY

Dedicated Distribution Center

With **centralized** inventory to support the Western Hemisphere, we've got you covered.



INNOVATION

Information Technology

With the **latest software and technology** we aim to provide a world-class customer experience.



PEOPLE

A Wealth of Experience

Decades of **experience** make our gearbox team some of the best in the industry.



QUALITY

Rigorous Standards

Assembled in Verona. ISO 9001 certified. Member of AGMA, PTDA, CSA, EASA. We don't compromise.

• Immersion Heater



• Creep Drive



• Heavy Duty Anti-Dust Breather



ACCESSORIES

• Solid Shaft



• Shrink Disc



• Keyed Hollow Bore



OUTPUTS

SPLIT HOUSING

Standard in large frame sizes to allow easy maintenance. A large inspection port provides a window for gear inspection. Available in standard gray cast iron with ductile and fabricated steel options.

TACONITE SEAL

3-part oil seal includes two double-lipped seals and a rechargeable grease chamber positioned between them to absorb contaminants. Abrasive particulates are purged using fresh grease. Supplied with NBR (Nitrile) as standard; optional FKM (Viton®) available.

SLOW SPEED SHAFT

JIS SCM440H or AISI 4140H material or equivalent, interfering/fitted keys, and interference fit gears. Suitable for stop/starts and reversing applications.

CASE-CARBURIZED & GROUND GEARING

High-precision carburized gearing with a 25° pressure angle offers a thicker dedendum and higher strength ratings than the typical 20° pressure angle.

HIGH-TENSILE SHAFT

Strong shaft material optimized for extended operation in rugged environments.

TIER 1 SUPPLIER ROLLER BEARINGS

High-capacity bearings increase load handling without extending lead times. Depending on size and configuration, units are equipped with tapered, double-row spherical, or cylindrical roller bearings.

PARAMAX® 9000

PARALLEL & RIGHT ANGLE LARGE INDUSTRIAL GEARBOXES

Paramax® parallel and right angle drives are some of the **largest and most durable** power transmission systems operating in the world. The series features **double, triple, quadruple reduction** gearboxes, global standardization and availability, and support from our worldwide facilities.

Optional Accessories: Backstops, motor mount options, seal upgrades, heating & cooling and lubrication solutions, paint upgrades, storage and packaging options, and complete drive package solutions.

DRIVE PACKAGE

Swing Base



Baseplate



Motor Adapter

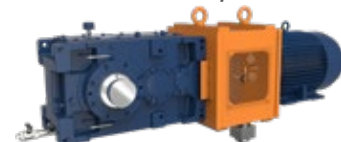

SPECS



HP RATING
Up to 5,230 HP
(3,900 kW)



DIAMETER
58mm to 360mm
(Hollow & Solid)



TORQUE
Up to 4.9 million lb•in
(552 kN•m)



RATIO RANGE
Up to 500:1
Standard

• **Keyed Hollow Bore**



• **Extended Bearing Housing**



• **Oversized Solid Shaft**



• **Normal Solid Shaft**



MIXER OPTIONS

• **Extended Bearing**



• **Pilot or Flange Mount**



• **Hollow Shaft**



OUTPUTS

SPLIT HOUSING

Rugged, split housing for horizontal and vertical applications. Round housing tops help keep the unit free from debris.



HANSEN P4

REMARKABLE POWER AND PERFORMANCE WITH LOW NOISE

The Hansen P4 multi-stage gearbox is **market leading in quality and technology**, excelling in **reliability and durability**. The rugged housing, along with our commitment to innovating state-of-the-art technology, provides remarkable **power and performance**.

GEARS

High-torque geometry in low-speed gears. Low-noise geometry in high-speed gears.



The unique **Oil-Lock®** system offers a **maintenance-free** seal on high speed shaft extensions, designed to keep the oil in and dirt out.

Optional Accessories: Backstops, motor mount options, multiple sealing upgrades, various heating, cooling, and lubrication options, heavy-duty paint or packaging options, and complete drive package solutions.

PINION SHAFTS

Rigid standardized pinion shafts and housings for better lateral load distribution.

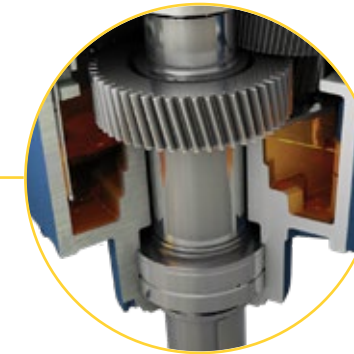

INTEGRATED DRYWELL

Cast directly into 3- and 4-stage vertical housings, this integrated drywell provides a truly leak-proof, low-speed shaft solution.

SLOW-SPEED SHAFT

Shaft projections include captured keyways with rounded end key inserts to eliminate stress concentrations.

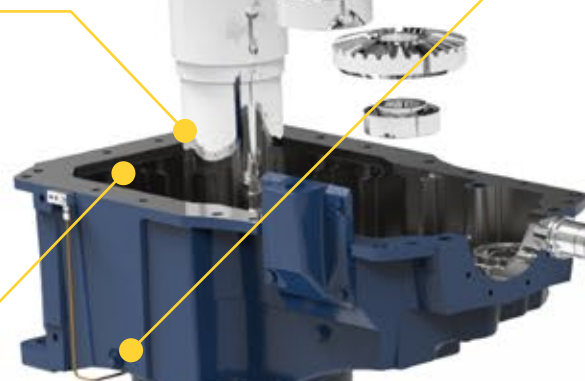

HIGH-SPEED SHAFT

Extra long high-speed shaft projections suitable for interference-free coupling connections.



LUBRICATION

Exceptional housing design ensures bearings are lubricated at start-up to maximize reliability and life.

MAINTENANCE-FREE OIL-LOCK®

Standard high-speed seal arrangement.

VARIATIONS

Vertical



Horizontal



Single-Stage



SPECS



HP RATING
Up to 14,080 HP
(10,500 kW)



DIAMETER
80mm to 400mm
(Solid, Heavy-Duty,
and Hollow)



TORQUE
Up to 9.7 million lb•in
(1.1 million N•m)



RATIO RANGE
Up to 630:1 (Custom
ratios available)

• Rigid Moment Coupler



• Motor Adapter

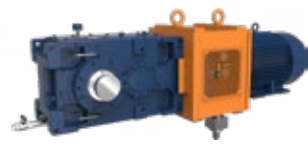

TYPICAL
OPTIONS

- Flexible or Hydro-Dynamic Couplings
- Motors including large heavy-duty
- Optional D-Flange or C-Face

MOTOR
ADAPTER
OPTIONS

FLIPPABLE HOUSING

Symmetrical housing with two inspection covers provides easy access for gearing maintenance.

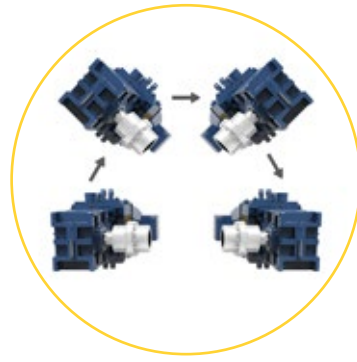

RUGGED HOUSING

Reinforced ribbing provides optimal strength in key areas. Designed to accommodate large motor mounting options.

CASE-CARBURIZED & GROUND GEARING

High-precision carburized gearing with a 25° pressure angle offers a thicker dedendum and higher strength ratings than the typical 20° pressure angle.

PARAMAX® UNIMINER

HEAVY-DUTY WITH ECONOMICAL FLIPPABLE HOUSING DESIGN

The Paramax® UniMiner is built on the **reliable existing product platform** and incorporates a **new housing design** that can **reduce** product inventories when both **left and right handed** assemblies are required.

Paramax® gearboxes are **compact** and **battle-tested in mining** and other heavy-duty applications. They excel in all types of bulk material handling applications and provide **long and trouble-free operation**.

Paramax® UniMiner can be a **direct drop-in** to most other alignment-free, shaft mounted drive packages.

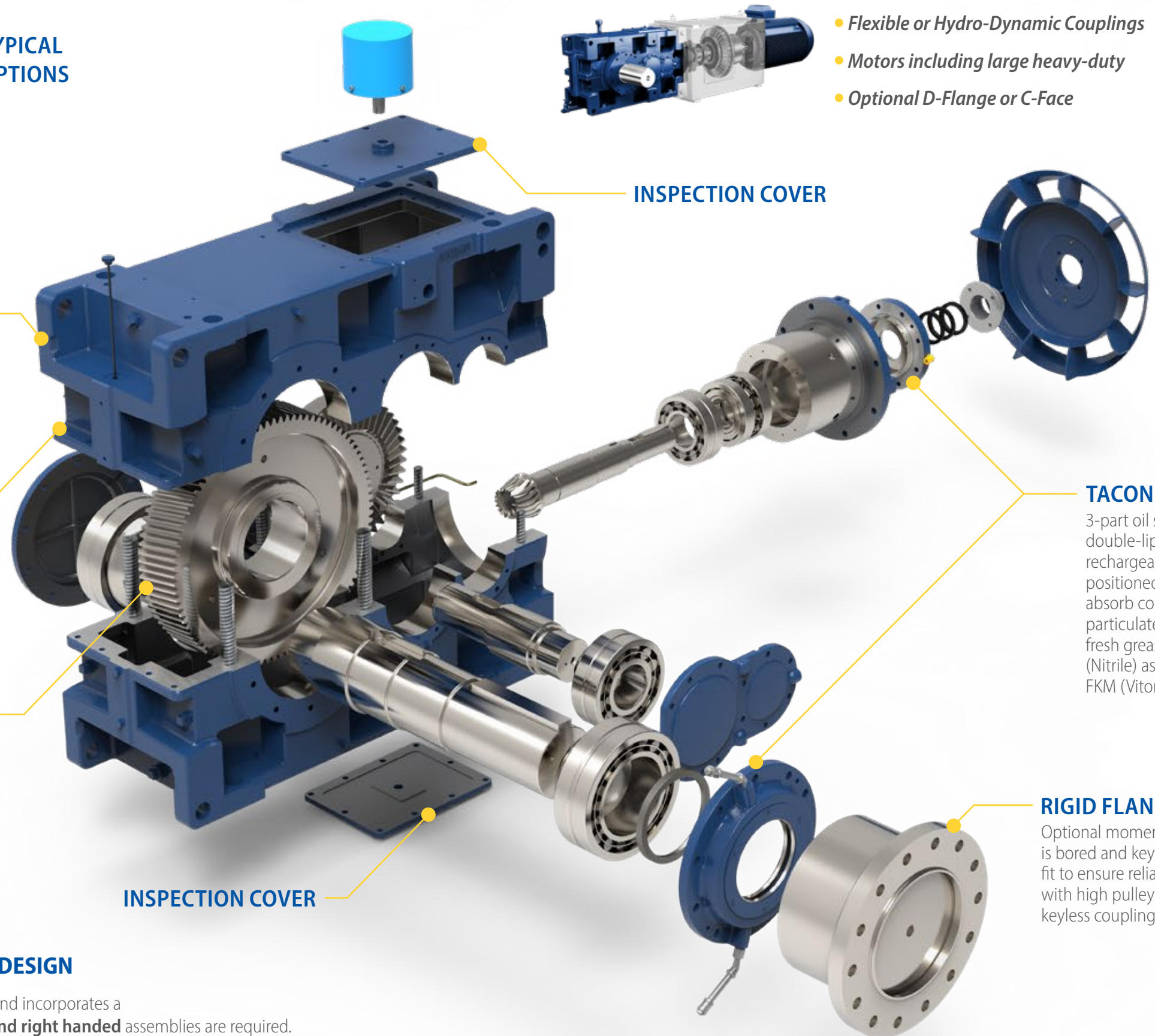

INSPECTION COVER

TACONITE TYPE SEALS

3-part oil seal includes two double-lipped seals and a rechargeable grease chamber positioned between them to absorb contaminants. Abrasive particulates are purged using fresh grease. Supplied with NBR (Nitrile) as standard; optional FKM (Viton®) available.

RIGID FLANGED COUPLING

Optional moment couplings. Standard is bored and keyed for an interference fit to ensure reliable operation even with high pulley run out. Optional keyless couplings with locking hubs.

INSPECTION COVER

SPECS



MOTOR RATED
Up to 1,250 Mhp



DIAMETER
95mm to 200mm
(Solid)



TORQUE
97,000 to 1,080,000 lb•in
(11 to 122 kNm)



RATIO RANGE
Series Standard
6.3 to 90:1

Retro-Fit units with transition bases allow us to match your existing footprint.

Custom drop-in units made to match existing unit's critical dimensions.

RETRO-FITS & DROP-INS

Whatever your requirements, **we have a solution** for you. Sumitomo Drive Technologies offers **customized bases** which allow our units to **match the footprint** of an array of existing applications and **drop-in gear drives** to **upgrade** and **replace** competitor units.

With a wide range of **options**, our **engineers** can replace your unit with **minimum impact** while delivering a **premier product** with **performance** and **reliability**.

RETRO-FIT

Match Existing Footprint

A **custom transition base** will position the new low-speed shaft to be in the **EXACT same position** as the original low-speed shaft. Our retro-fits provide an **excellent balance** between the cost savings of a standard gearbox and the benefits of minimal on-site modifications.

Typically, only relocating the motor mount is required for this option. We offer **motor mounting options** to help **minimize the impact** of relocating the motor mount, such as flanged motor adapter for c-face or d-flange motors.

Options might include a special low-speed shaft diameter or length and motor lantern.

The **red circles** in the diagram represent the **existing bolt pattern** of a customer's unit. The transition base is fabricated to match the height, **ensuring alignment** of the low-speed shaft to the machine shaft.

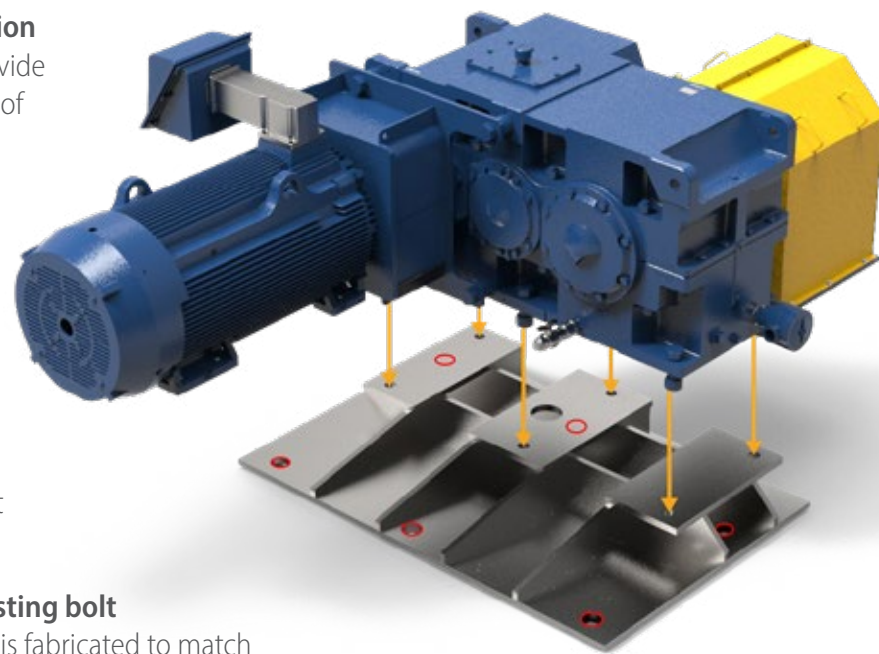

DROP-IN

Match Existing Unit's Critical Dimensions

With **downtime** being such a **critical factor** in your operation, **let us install** one of our custom drop-in units.

Installation-ready units are designed specifically to **drop-in to existing applications** with ease. Our **expert engineers** understand that on-site modifications or re-engineering your system is not always an option.

These **stress-free replacements** can have your application back up and running in **no time**. We offer fabricated steel housings, custom baseplates, custom gearing and shafting, and more!

This product will literally drop-in to place; same footprint, same shaft positions!

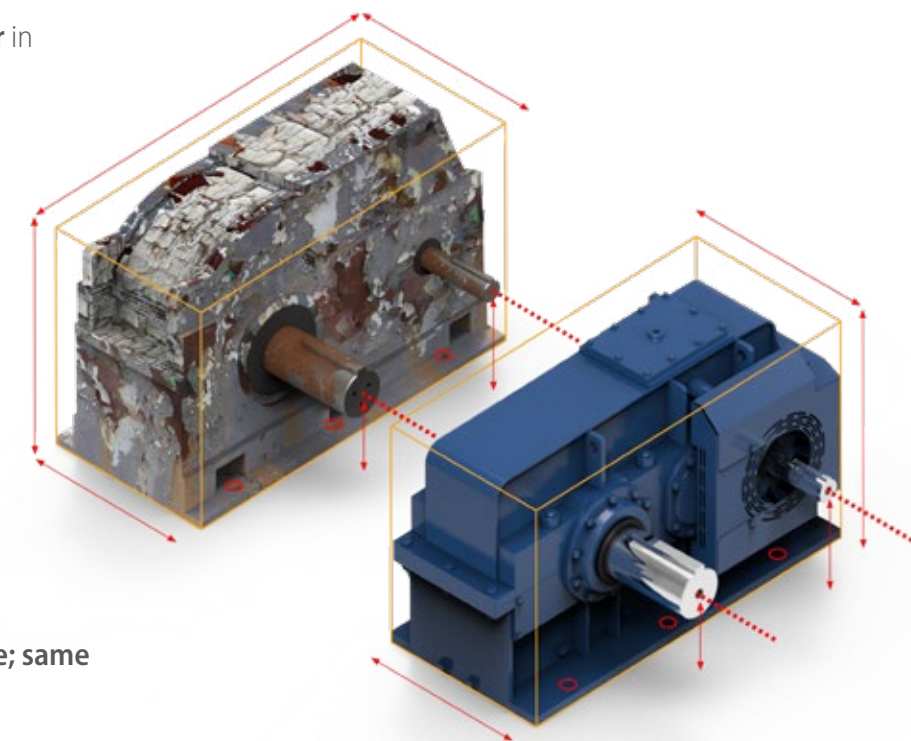

SPECIALTY UNITS

For **non-standard gearing** and **custom ratios**, we offer special customized units to fit in **any application**.

From custom paint to intricate gearbox lubrication systems, **our team of engineers** will make sure all of your custom gearbox needs are met.

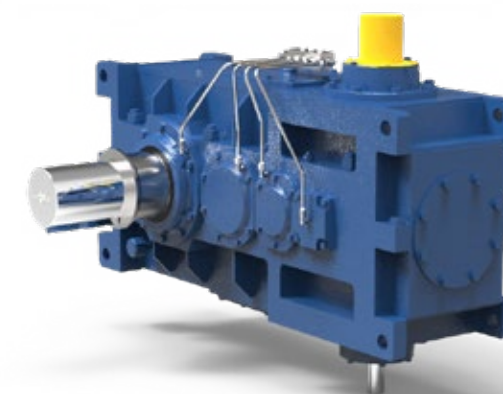

*We take asset management seriously,
because we know you do.*

*Avoid catastrophic failure, minimize risk
and increase machine uptime.*

SYSTEM MANAGEMENT AND RELIABILITY TECHNOLOGY (SMART)

SMART is a range of products and reducer options that were developed to help end users in their **reliability** and **asset management** initiatives within their plant's daily operations.



Condition Monitoring

Fully customizable systems provide real time condition data of any piece of rotating equipment. Providing an accurate condition signal without the need for further analysis.

All Gearboxes

OPTIONS **

- Vibration + Temperature Input
- Vibration + Oil Level Input
- Vibration + Oil Condition

WE THINK!



Reliability Monitoring

These reducer option packages will help in the consistent collection of data. For Vibration analysis, as well as oil condition and cleanliness testing.

Large Industrial Gearboxes

OPTIONS*

- Opt 1: Machined Accelerometer Mounting Pads Only
- Opt 2: Opt 1 + Accelerometers Wired to Junction Box
- Opt 3: Opt 2 + Outputs to Customer PLC or DCS

YOU THINK!

■ CYCLOSMART® BENEFITS

- **Safe**
Monitor assets from the safety of your desk via networked connections.
- **Predictive**
Machine diagnostics for early warning and detection to avoid failure.
- **Optimization**
Customizable systems to meet many different application needs.
- **Expandable**
Multi-reducer monitoring.
- **Reliable**
Schedule machine downtime to avoid lost production.
- **Cost-Effective**
Lower overall ownership cost.

the **CHECK** 
ENGINE LIGHT for
SPEED REDUCERS

* All DriveSMART options include: Hydrosopic breather with 3mm filter, drain/fill connection for on-line filtration, and oil sample pitot tube port.

** All CycloSMART® systems are customizable with many different options for data monitoring. Examples are shown.

Learn more at:
US.SumitomoDrive.com/CycloSmart



Our factory capabilities support all of your gearbox needs.

The most reliable and highest quality products backed by a 400 year heritage.

AFTERMARKET

Our personnel are the **industry's most versed gearbox problem solvers**. We provide both standard and tailored services, for **maximum** gearbox life.

REPAIRS

Scheduled & Emergency Repair

Repair services for **all** your related gearbox needs and **24-72 hour turnaround** to the **original** factory specifications and **warranty** using Sumitomo Drive Technologies-manufactured parts.

Extended warranty programs are available upon request.

ROOT CAUSE INVESTIGATION

Product Support

Apply a **wide range** of approaches, tools and techniques to uncover the **causes** of your problems.

ON-SITE INSPECTIONS & MAINTENANCE

For Your Convenience

Most of the **services** offered and customized **training** can be performed **on location**.

EXPERTS IN SERVICE

Global Support, Local Service

With a **vast network** of engineers and gearing experts, there's **no challenge** we can't tackle.

Our **Luftex facility**, a core part of our operation, brings **unmatched capabilities** and deep **expertise** in **custom** gearbox repair and service. Equipped with state-of-the-art technology, we're built to handle even the **largest** and most **complex** gearboxes.

Sumitomo Drive Technologies

LUFTEX

From custom gear manufacturing to on-site gearbox repair, count on the team at our **Luftex facility** to keep your operation **running smoothly**.

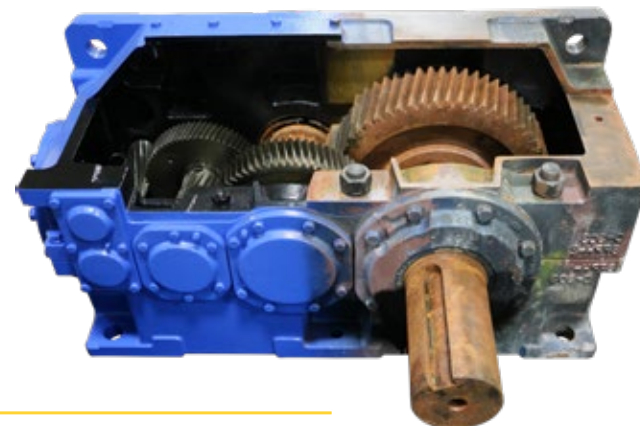

WHY SUMITOMO?

The **history** of the Sumitomo Group started more than **400 years ago** when Masatomo Sumitomo opened a book and pharmacy store in the city of Kyoto, Japan. **Today**, the **Sumitomo Group** consists of more than **20 companies** who share the Sumitomo Emblem as well as many common values and ideals.

DEVOTED TO QUALITY

In addition to one of the most **comprehensive product lines** of any power transmission company, we offer the most **reliable** and **highest quality** products available in the industry.

Whether it's product development or manufacturing processes, our **quality culture** resonates through our entire **global network**.

COMMITTED TO OUR EMPLOYEES AND THE COMMUNITY

We recognize our **employees** are our most valuable asset. They are the **driving force** behind our innovative products, our ability to support our customers, and our commitment to continuous process improvement.

We strive to be a **valuable member of society** and take pride in the contributions we make to our **communities** across North and South America.

DEDICATED TO INNOVATIVE MANUFACTURING

With more than a **century of expertise** in manufacturing, our global **capabilities** are **unmatched** in the industry.

We have manufacturing and assembly facilities on **every continent** and continue to make investments in our manufacturing technologies to maintain our position as a **leader in innovation**.

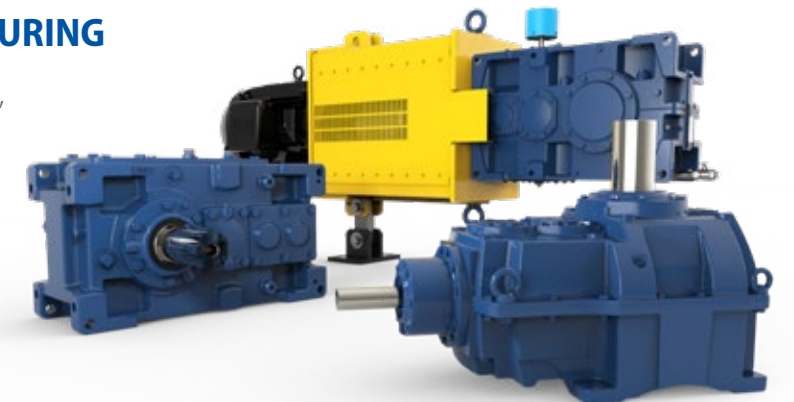

email: SMA.Service@shi-g.com

phone: [757-485-3355](tel:757-485-3355)

web: US.SumitomoDrive.com