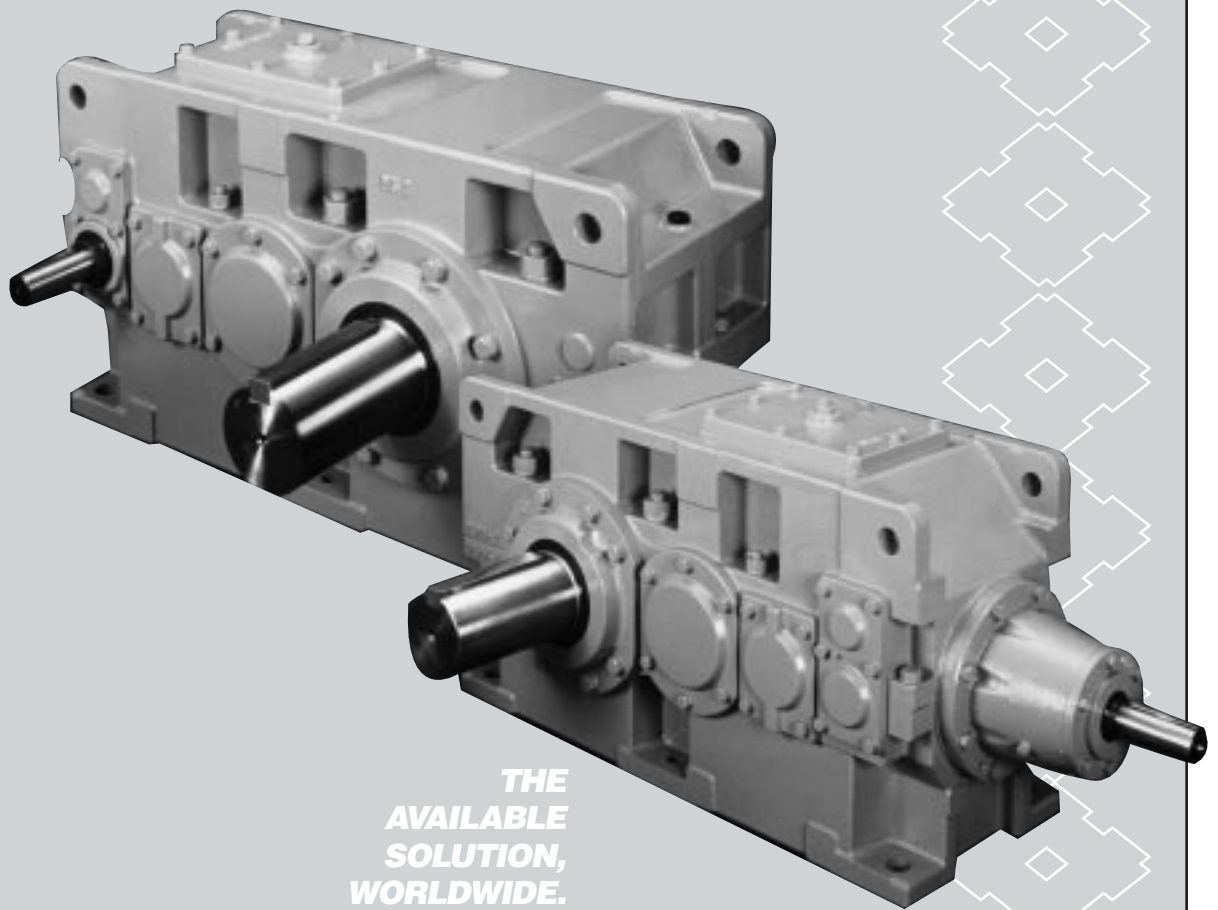


PARAMAX

Parallel Shaft & Right Angle Speed Reducers

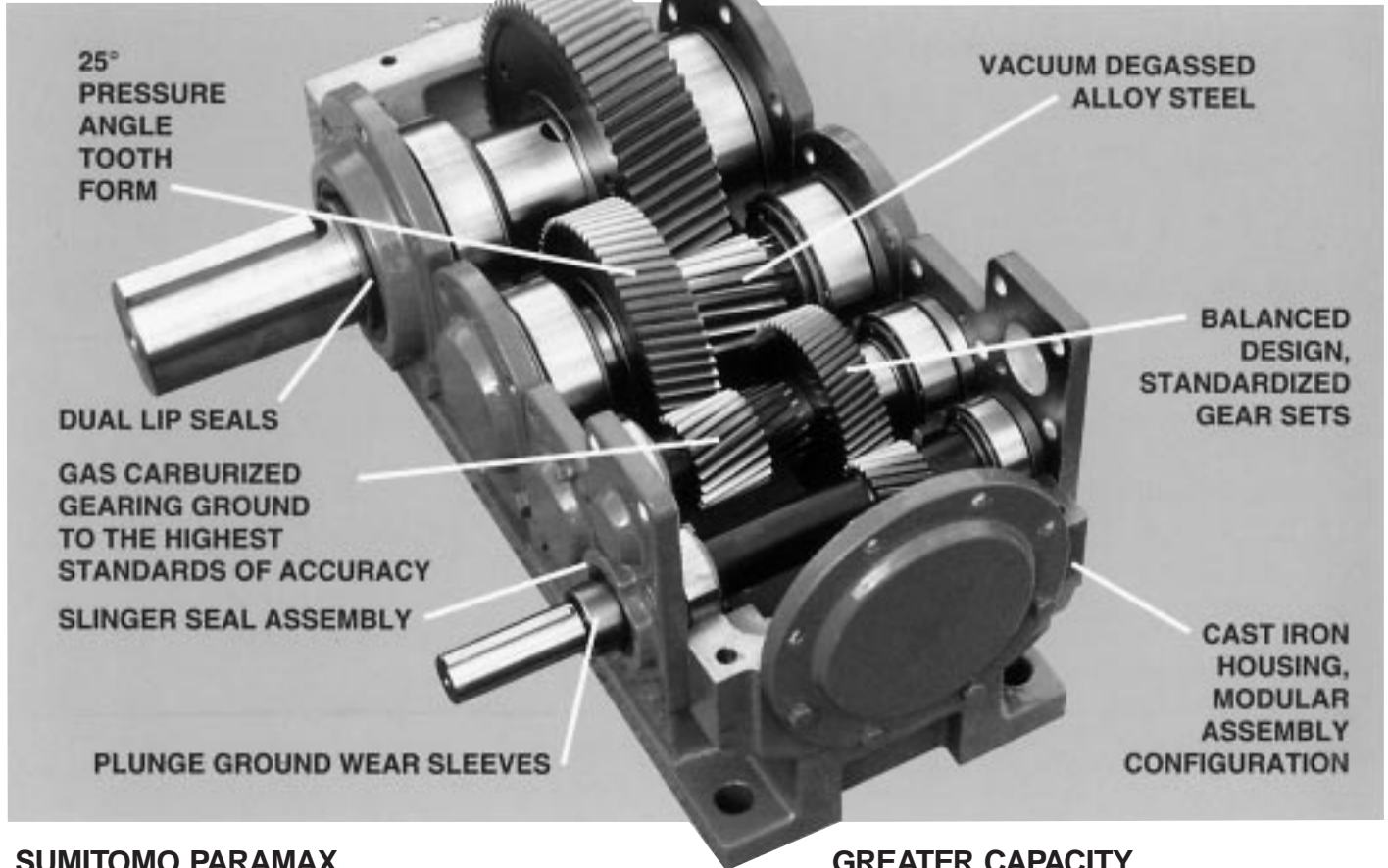
Maintenance Manual



NOTE:

- PARAMAX Units should be handled, installed and maintained by trained technicians. Carefully read the maintenance manual before use.
- Oil is removed from PARAMAX Units before shipment. Fill with oil according to the maintenance manual before operation.
- A copy of this maintenance manual should be sent to the actual user of PARAMAX.
- This maintenance manual should be maintained by the user.

PARAMAX "The Available Solution, Worldwide."



SUMITOMO PARAMAX

Sumitomo has applied in excess of 50 years of speed reducer experience to the design and manufacture of PARAMAX Parallel Shaft and Right Angle Speed Reducers. During this time we have designed and built some of the largest, most durable and trouble-free speed reducers in the world. Our fully integrated engineering and production facilities are equipped to provide prompt delivery of products manufactured to exacting standards at a competitive price. A worldwide network of regional offices, sales representatives, distributors and service technicians provides qualified, on-the-spot field service wherever and whenever you need it.

FEATURES

ECONOMY, STANDARDIZATION, INTERCHANGEABILITY

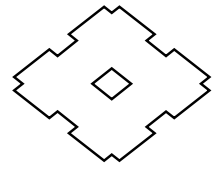
Featuring a concept of standardized gear set design and manufacture, PARAMAX® offers the most economical and uniformly high-quality product available for demanding parallel shaft and right angle applications. Standardization also provides the added economy and value of interchangeability of gear sets from size to size.

GREATER CAPACITY, QUIET, TROUBLE FREE

Produced with special Vacuum Degassed Alloy Steel, helical gearing in the PARAMAX series is machined using the protuberance hobbing method to generate a tooth having an increased helix angle and pressure angle. After machining, the teeth are gas carburized, heat treated and ground to the highest standards of accuracy. Spiral Bevel gearing is also carburized, heat treated and finished to the same standards. The result is greater capacity, smoother, quieter operation and longer trouble-free life than conventional hardened and ground gearing.

COMPUTER-AIDED DESIGN, MAXIMUM EFFICIENCY

Ratios and dimensions of each stage of gearing are optimized through the latest computer-aided design technology.



Safety and Other Precautions


- Carefully read this maintenance manual and all accompanying documents before use (installation, operation, maintenance, inspection, etc.). Thoroughly understand the machine, information about safety, and all precautions for correct operation. Maintain this manual for future reference.
- Pay particular attention to the “DANGER” and “CAUTION” warnings regarding safety and proper use.



: Improper handling may result in physical damage, serious personal injury and/or death.



: Improper handling may result in physical damage and/or personal injury.

Matters described in  may lead to serious danger depending on the situation. Be sure to observe important matters described herein.

DANGER

- Transport, installation, plumbing, operation, maintenance, and inspections should be handled by properly trained technicians; otherwise, injury or damage to the machine may result.
- When the unit is to be used in a system for transport of human beings, a secondary safety device should be installed to minimize chances of accidents resulting in injury, death, or damage to the system.
- When the unit is to be used for an elevator, install a safety device on the elevator side to prevent it from falling; otherwise, serious injury, death, or damage to the elevator may result.

CAUTION

- The unit should be operated only within its design and performance specifications; otherwise, injury or damage to a system may occur.
- Keep hands and all foreign objects from the internal moving parts of the unit; otherwise, injury or damage to a system may occur.
- Damaged units should be taken off-line and not put back in operation until properly repaired.
- Any modifications or alterations of any kind, to the unit, will void the warranty and all subsequent claims.
- Do not remove the rating plate.

- Oil has been removed from PARAMAX DRIVE before shipment from our factory. Fill with oil before use.

CONTENTS

	Page
Safety and other precautions	1
Inspection upon delivery	2
Storage	3
Transportation	3
Installation	3
Coupling with other machines	4
Lubrication	8
Operation	10
Daily inspection and maintenance	11
Troubleshooting	12
Disassembly/reassembly and disposal	12
Construction drawings	13
Oil quantity	19
Oil seal dimensions	20
Bearings	21
Locations of oil filler and drain plug	24
Warranty	24

Inspection Upon Delivery

⚠ CAUTION

- Unpack the unit after verifying that it is positioned right side up; otherwise, injury may result.
- Verify that the unit received is in fact the one ordered. When a different product is installed, injury or damage to the system may result.



Upon delivery of the PARAMAX check the following:

- ① The descriptions on the rating plate conform to your order.
- ② There were no parts damaged during transport.
- ③ All bolts and nuts are firmly tightened.

If there is any doubt that the unit delivered conforms to the one ordered, contact the nearest agent, distributor or service office.

1-1) How to check the rating plate

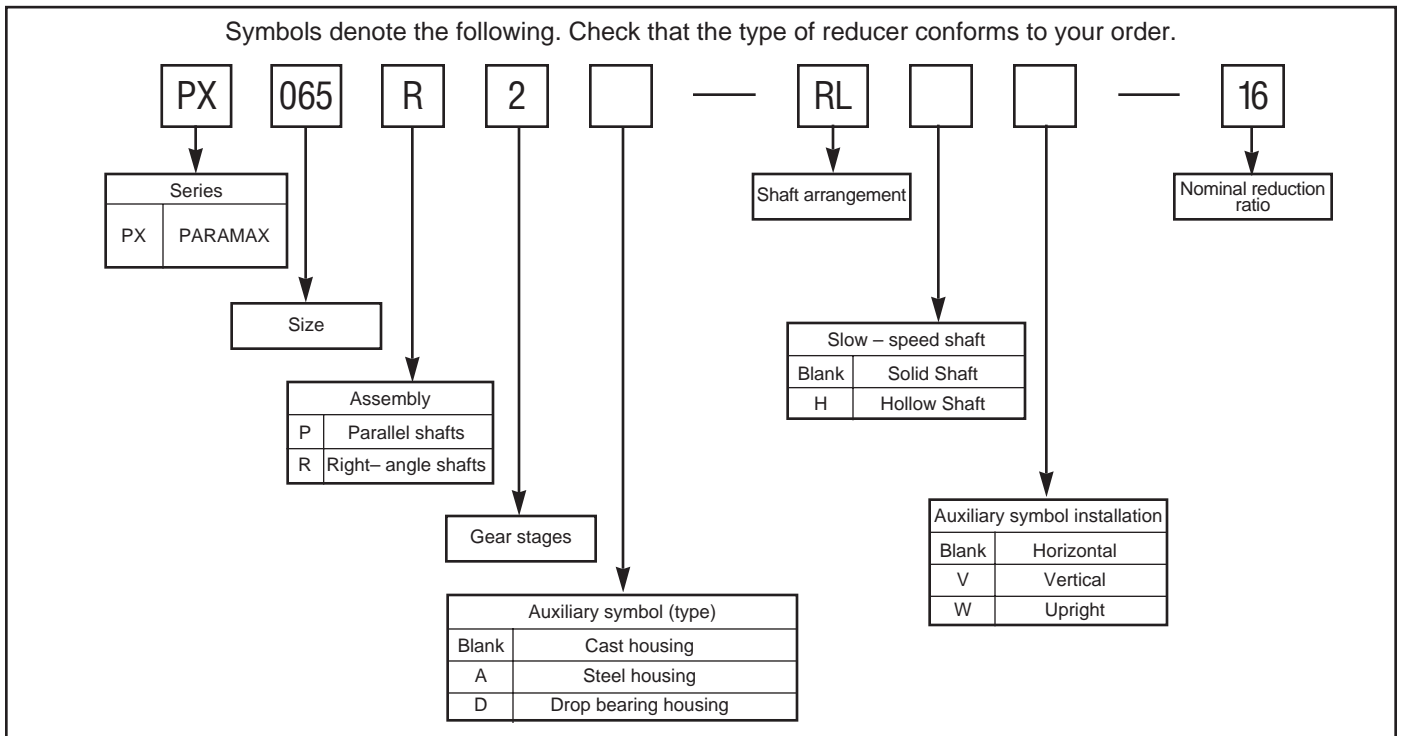
- ① Type of speed reducer (Details shown below)
- ② Serial number
- ③ Reduction ratio

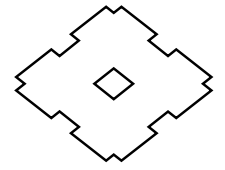
PARAMAX®		
MODEL _____		
SERIAL NO. _____		
INPUT HP _____		
INPUT RPM _____		
HP RATING _____		
RATIO _____		
DATE _____		
	AGMA LUB.	
	OUTPUT SPEED	AMB. TEMP. °F
	14-50	50-95
	50-131	95-131
	RPM <N	4 EP 6 EP 8 EP
	RPM >N	3 EP 5 EP 7 EP
	N SIZE	
	400	8015-8035
	200	8045-8085
	120	8090-8115
	75	8120-8135
	CHANGE OIL EVERY 6 MO. OR 2500 HRS WHICHEVER OCCURS FIRST. USE INDUSTRIAL TYPE PETROLEUM BASED (EP) GEAR OIL.	
 SUMITOMO MACHINERY CORP. OF AMERICA CHESAPEAKE, VIRGINIA		PMPA2133

Rating plate of reducer

- Have the ① MODEL, ② SERIAL No., ③ RATIO information ready when making inquiries.

1-2) Types of reducers





Storage

When storing PARAMAX for any extended periods of time before use, consider the following important points.

2-1) Temporary storage

- (1) Store PARAMAX in a clean, dry, covered storage area.

- Do not store PARAMAX outdoors or in a wet location.

2-2) Long-term storage

- (1) The oil seals will deteriorate when exposed to high temperatures and UV rays. Inspect and replace the oil seals after long-term storage if there are any signs of damage or cracking.
 - (2) After starting PARAMAX, check that it is free from abnormal sound, vibration, or heat build-up. If any kind of anomaly is observed, contact the nearest agent, dealer, or service office immediately.
 - (3) Every 2-3 months after shipment, operate PARAMAX with the recommended lubricant for 5-10 minutes. If this is not possible, or when PARAMAX is to be stored for more than 6 months, fill the unit with the proper amount of vapor phase inhibitor (Shell VSI 32 or equiv.) according to the inhibitor manufacturer's recommendations.
 - (4) As an alternative to (3), fill the gearcase completely with the normal operating oil grade, plug the air vent and rotate shafts occasionally (every 3 months).
-

Transport

CAUTION

- Exercise ample care not to drop PARAMAX during transport. When a hanging bolt or hole is provided, be sure to use it. After mounting PARAMAX on a system, however, do not hoist the entire system using the hanging bolt or hole. Before hoisting, check the weight with the rating plate, crate, outline drawing, catalog, etc. Never hoist a PARAMAX that exceeds the rating of the crane or other mechanism being used to lift it; otherwise, injury or damage to the unit and/or lifting device may occur.
-

Installation

DANGER

- Never stand directly under a unit suspended by a crane or other lifting mechanism; otherwise, personal injury or death may result.

CAUTION

- Do not place any objects that will hinder ventilation around PARAMAX; otherwise, cooling effect is reduced, and this may lead to a possible fire hazard due to excessive heat build-up.
- Do not step on or hang from PARAMAX; otherwise, injury may result.
- Do not touch the key at the shaft end or on the inside of PARAMAX; otherwise, injury may result.
- When PARAMAX is used in food processing applications vulnerable to oil contamination, install an oil pan or other such device to cope with oil leakage due to failure or limited service life. Otherwise, oil leakage may damage products.

4-1) Location of installation

Ambient temperature: 15 to 105°F

Ambient humidity: 85% max.

Ambient atmosphere: There shall be no corrosive gas, explosive gas, or steam.

The installation space shall be well ventilated, and free from dust.

Location of installation: Indoors

- Special specifications are necessary when installation conditions are other than those mentioned here. In such cases, contact the nearest agent, dealer or service office.
 - When a product is made according to special specifications for outdoor use or use in explosive environments, the product can be safely operated under those specified conditions without problem.

4-2) Installation angle

The installation angle shall be within the limits shown in Fig. 1.

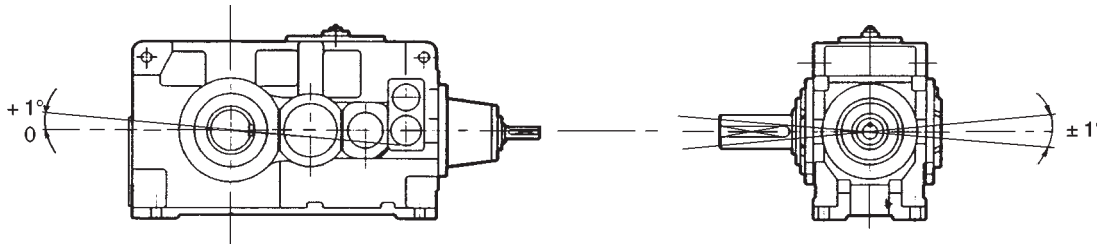


Fig. 1 Limits for installation angle

- Install PARAMAX on a sufficiently rigid base.
 - Use installation bolts corresponding to SAE strength class 8 or its equivalent.

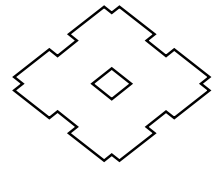
4-3) Foundation

Reducer must be mounted on a rigid foundation which prevents flexing, vibration or shaft misalignment. The reducer must be level within .002" per foot, both front to back and side to side.

Coupling With Other Machines

CAUTION

- Install appropriate guard devices around rotating parts; otherwise, injury may result.
- When coupling PARAMAX, confirm that the alignment error is within the coupling manufacturer's specified limits shown in the maintenance manual, drawings, catalog, etc.; otherwise, damage to the system may result.
- Correctly tighten respective bolts to the specified torque shown in the drawing, catalog, etc.; otherwise, injury may result from disintegrating couplings.
- When a belt is used for coupling the unit with another machine, check that the belt tension and the parallelism of the pulley are within the specified limits. When the unit is directly coupled with another machine, check that the direct coupling accuracy is within the specified limits; otherwise, the system may be damaged due to misalignment.
- Remove the key temporarily attached to the output shaft of PARAMAX when the shaft is free-rotating (i.e., not coupled); otherwise, injury may result.
- Confirm the direction of rotation before coupling PARAMAX with its driven machine. Incorrect direction of rotation may cause injury or damage to the system.



5-1) Installation of coupler

- When attaching a coupler, be careful not to apply impact force or excessive thrust to the shaft; otherwise, the bearing may be damaged.
- Shrink fit or shaft-end thread is recommended for mounting (Fig. 2).

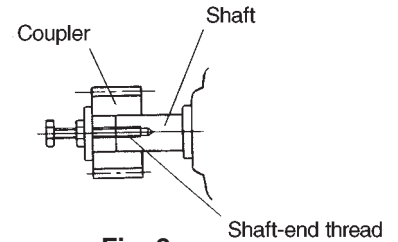


Fig. 2

(1) Use of coupling

The dimensions (A, B, and X) illustrated in Fig. 3 shall be within the tolerance shown in Table 1.

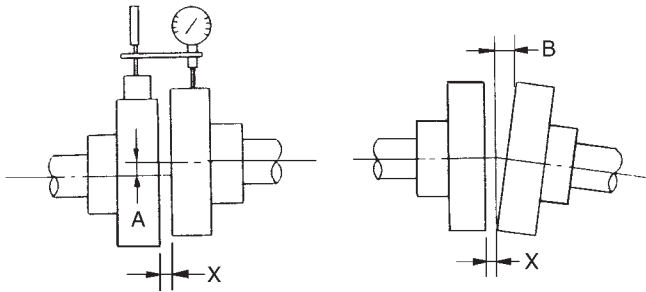


Fig. 3

Table 1 Aligning tolerance for coupling

Tolerance for A dimension	0.002"
Tolerance for B dimension	0.002"
X dimension	Specified by coupling manufacturer

(2) Use of chain, sprocket, or gear

- The chain tension angle shall be perpendicular to the shaft of PARAMAX.
- The pitch circle of the sprocket or gear shall be more than three times the shaft diameter.
- Locate the sprocket or gear as close to PARAMAX as possible so that the point of application of the load will be closer to the PARAMAX vertical centerline (Fig. 4).

(3) Use of V belt

- Excessive V belt tension will damage the shaft and bearing. The amount must be specified by V belt manufacturer.
- Accuracy of parallelism (β) between two pulleys shall be less than $20'$ (Fig. 5).
- Use a matched set with identical circumferential length when more than one V belt is used.

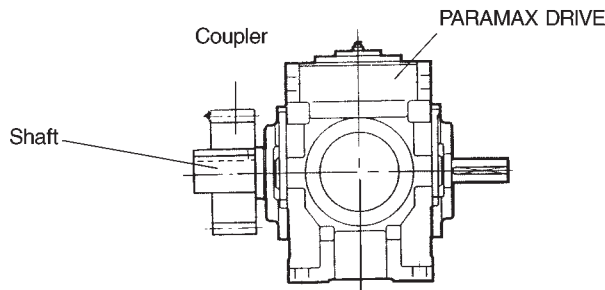


Fig. 4

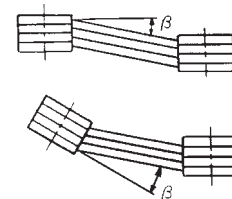


Fig. 5

5-2) Hollow shaft

5-2-1) Shrink disc type

The shrink disc has a keyless shrink fit mechanism which shrinks hub (HB) mechanically through the tightening locking bolt (ZS), and holds shaft and hub as one fixture (Fig. 6).

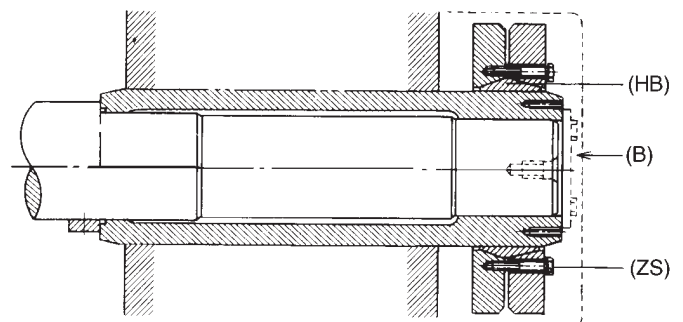


Fig. 6 Full mounted position

Mounting procedure (Fig. 7)

- (1) Clean and degrease contact surfaces (a) and (c).
- (2) Smear surface (c) with "Molykote 321" or its equivalent. However, keep surface (a) as clean as possible (no grease).
- (3) Slide O-ring (b) onto the shaft.
- (4) Mount the reducer on the driven shaft and screw nut (e) until faces (g) and (h) make contact.
- (5) Set the shrink disk (k) at dimensions (LV). Tighten locking bolt (ZS) at specified torque (TA) (using a torque wrench).

Make sure that both plates are parallel when tightening bolts. After confirming that the shrink disc is set correctly, tighten the bolts with a wrench of appropriate length. Uniformly tighten bolts clockwise (not diagonally) while keeping both plates parallel. It is recommended to tighten respective bolts by 30° each time.

Note 1. In case of a vertical type unit, mount a thrust washer (B) to prevent the reducer from moving when locking nut (ZS) is loosened (Fig. 6).

Note 2. A high-tensile bolt (SAE Grade 8) is used as a locking bolt (ZS). When replacing it, use one specified by the manufacturer.

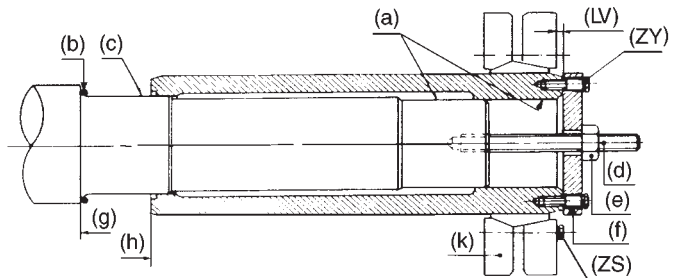


Fig. 7 Mounting

Removal procedure (Fig. 8)

- (1) Loosen locking bolt (ZS) and remove shrink disc (k).
- (2) Set thrust washer (f) and hexagon head bolt (n). Remove the reducer from the driven shaft using bolt (m).

Note: Parts (d), (e), (f), (ZY), (m), and (n) are optional. Order these as required.

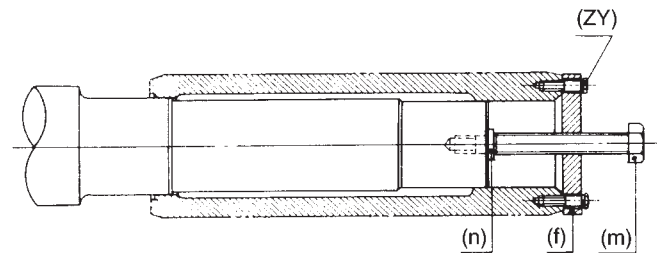


Fig. 8 Removal

5-2-2) Key way connection

The hollow shaft bore is provided with retaining ring (d). Ring (d) is the essential component for mounting, securing and removing the unit.

Mounting procedure (Fig. 9)

- (1) Slide O-ring (i) over the driven shaft.
- (2) Smear surface of shaft (e) with molybdenum disulfide grease.
- (3) Turn nut (b) and slide the reducer over the driven shaft. Use ring (c) as necessary.

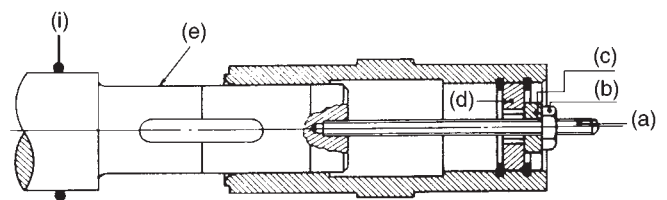


Fig. 9 Mounting

Securing (Fig. 10)

- (1) After mounting the reducer on the driven shaft, fix bolt (f). (Bolt (f) is not supplied with the unit.)
- (2) The bore should be protected by cover (g).

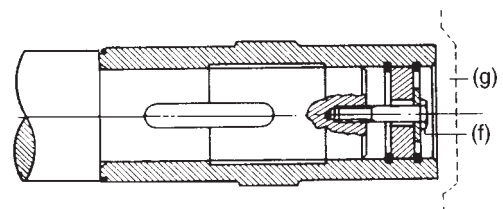
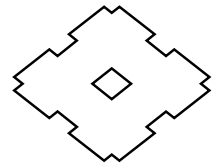


Fig. 10 Securing



Special Cases (Fig. 11)

(1) If the driven shaft has no shoulder (Fig. 11) when mounting, provide a distance ring (h) for fixing in place. (Distance ring (h) is not supplied with the unit.)

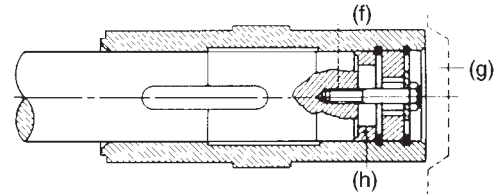


Fig. 11 Securing (driven shaft without shoulder)

Removal procedure (Fig. 12)

(1) Remove ring (d), mount bolt (n), and reset ring (d). Attach bolt (J) to ring (d), and turn bolt (J) to disconnect the hollow shaft from the driven shaft.

Note 1. Parts (a), (b), (c), (n), and (J) are optional. Order these as required.

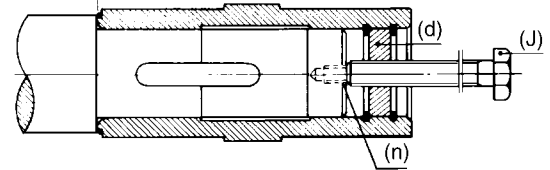


Fig. 12 Removal

5-2-3) Torque arm – (The torque arm is optional.)

The hollow shaft reducer is fixed by the torque arm to prevent the reducer from revolving by an opposite reaction force. Fig. 13 shows the construction of a standard torque arm. Select a torque arm support with proper construction and strength, taking into consideration the reaction force of the reducer and the impact load.

Note 1. The number of disc spring(s) differs according to the size of the reducer.

Note 2. Use bolt (T) and nut (M) classified as SAE strength class 8.

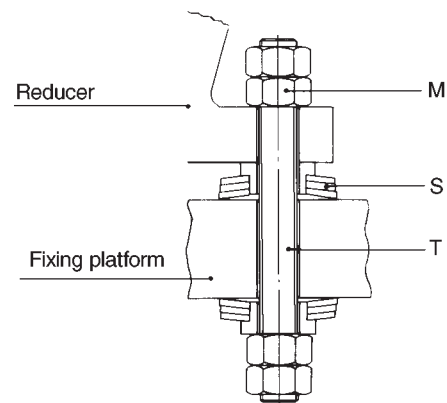


Fig. 13 Standard torque arm

Fig. 14 Hollow shaft dimensions (shrink disc type)

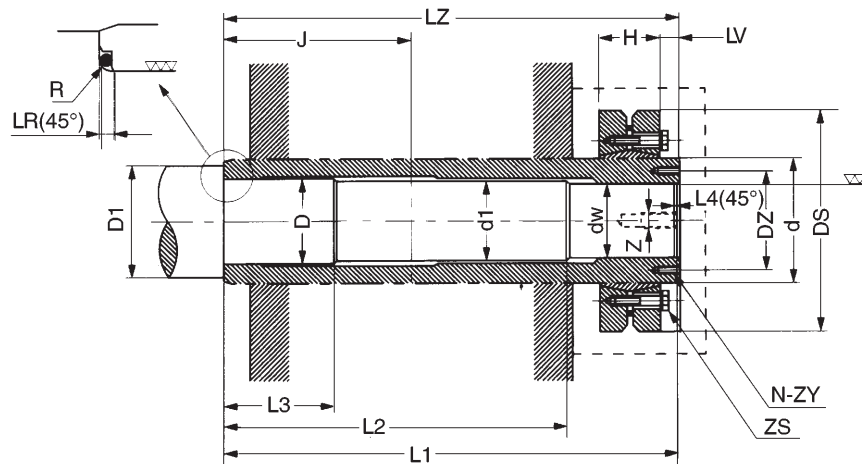


Table 2 Hollow shaft dimensions

INCH

PX-8 MODEL	Shrink Disk						Hollow Shaft						Machine Shaft									
	MODEL	d	Ds	H	Screws		J	LZ	LR	LV	N-ZY	DZ	dw	d1	D h7	D1 min	L1	L2	L3	L4	R	Z (DEPTH)
8015	HSD-81x80	3.15	5.43	1.22	M8	260	5.31	12.91	0.12	0.55	4 - M6	2.76	2.375 h6	2.40	2.500	3.125	12.80	9.45	3.15	0.12	0.10	M20(1.18)
8025	HSD-81x90	3.54	6.10	1.50	M8	260	5.71	14.09	0.12	0.55	4 - M6	3.15	2.750 h6	2.80	2.875	3.500	13.98	10.63	3.15	0.12	0.10	M20(1.18)
8035	HSD-81x100	3.94	6.69	1.69	M8	260	6.30	15.47	0.12	0.55	4 - M6	3.54	3.125 h6	3.19	3.250	3.875	15.35	11.61	3.54	0.12	0.10	M20(1.18)
8045	125PSV5004	4.92	8.46	2.56	M12	885	7.09	17.64	0.12	0.79	4 - M8	4.33	3.625 h6	3.78	3.750	4.375	17.52	13.19	4.33	0.12	0.10	M24(1.38)
8055	140PSV5004	5.51	9.06	2.91	M12	885	7.87	19.80	0.12	0.87	4 - M10	4.88	4.250 h6	4.17	4.375	4.875	19.69	14.96	4.33	0.12	0.10	M24(1.38)
8065	165PSV5004	6.50	11.42	3.46	M16	2200	9.06	22.95	0.12	1.06	4 - M12	5.75	5.000 h6	4.96	5.125	6.125	22.83	17.13	5.12	0.12	0.10	M24(1.38)
8075	185PSV5003	7.28	12.99	3.39	M16	2200	10.24	25.35	0.22	1.02	4 - M12	6.57	5.875 h6	5.75	6.000	6.861	25.20	18.70	6.30	0.20	0.10	M30(1.77)
8085	220PSV5003	8.66	14.57	4.09	M16	2200	11.22	28.11	0.22	1.02	4 - M12	7.68	6.750 g6	6.73	6.875	8.125	27.95	20.47	7.48	0.20	0.18	M30(1.77)
8090	240PSV5003	9.45	15.94	4.29	M20	4300	13.78	33.23	0.24	1.06	6 - M12	8.46	7.375 g6	7.40	7.500	8.375	33.07	25.00	7.87	0.20	0.18	M36(2.17)
8095	260PSV5003	10.24	16.93	4.72	M20	4300	13.78	33.82	0.24	1.06	6 - M12	9.06	7.875 g6	7.91	8.000	8.750	33.66	25.20	8.07	0.20	0.18	M36(2.17)
8100	TAS3081.1-260	10.24	17.32	4.72	M20	4800	15.35	36.77	0.24	1.06	6 - M12	9.25	8.250 g6	8.31	8.375	9.250	36.61	27.76	8.46	0.20	0.18	M36(2.17)
8105	TAS3081.1-260	11.02	18.11	5.28	M20	4800	15.35	37.36	0.24	1.06	6 - M12	9.84	8.625 g6	8.70	8.875	9.625	37.20	28.15	8.86	0.20	0.18	M36(2.17)
8110	TAS3081.1-300	11.81	19.09	5.59	M20	4800	16.54	40.55	0.24	1.26	6 - M12	10.63	9.375 g6	9.49	9.500	10.375	40.35	30.31	9.65	0.20	0.18	M36(2.17)
8115	TAS3091-320	12.60	20.47	7.24	M20	4350	16.54	41.93	0.24	1.26	6 - M12	11.22	9.875 g6	9.88	10.000	10.750	41.73	30.91	9.65	0.20	0.18	M36(2.17)

METRIC

PX-8 MODEL	Shrink Disk						Hollow Shaft						Machine Shaft									
	MODEL	d	Ds	H	ZS	TA N-m	J	LZ	LR	LV	N-ZY	DZ	dw	d1	D h7	D1 min	L1	L2	L3	L4	R	Z (DEPTH)
8015	HSD-81x80	80	138	31	M8	29	135	328	3	14	4 - M6	70	60 h6	61	63	79	325	240	80	3	2.5	M20(30)
8025	HSD-81x90	90	155	38	M8	29	145	358	3	14	4 - M6	80	70 h6	71	73	89	355	270	80	3	2.5	M20(30)
8035	HSD-81x100	100	170	43	M8	29	160	393	3	14	4 - M6	90	80 h6	81	83	98	390	295	90	3	2.5	M20(30)
8045	125PSV5004	125	215	65	M12	100	180	448	3	20	4 - M8	110	95 h6	96	98	111	445	335	110	3	2.5	M24(35)
8055	140PSV5004	140	230	74	M12	100	200	503	3	22	4 - M10	124	105 h6	106	108	127	500	380	110	3	2.5	M24(35)
8065	165PSV5004	165	290	88	M16	250	230	583	3	27	4 - M12	146	125 h6	126	128	147	580	435	130	3	2.5	M24(35)
8075	185PSV5003	185	330	86	M16	250	260	644	5.5	26	4 - M12	167	145 h6	146	148	174	640	475	160	5	2.5	M30(45)
8085	220PSV5003	220	370	104	M16	250	285	714	5.5	26	4 - M12	195	170 g6	171	173	197	710	520	190	5	4.5	M30(45)
8090	240PSV5003	240	405	109	M20	490	350	844	6	27	6 - M12	215	190 g6	191	193	212	840	635	200	5	4.5	M36(55)
8095	260PSV5003	260	430	120	M20	490	350	859	6	27	6 - M12	230	200 g6	201	203	222	855	640	205	5	4.5	M36(55)
8100	TAS3081.1-260	260	440	120	M20	540	390	934	6	27	6 - M12	235	210 g6	211	213	234	930	705	215	5	4.5	M36(55)
8105	TAS3081.1-260	280	460	134	M20	540	390	949	6	27	6 - M12	250	220 g6	221	223	244	945	715	225	5	4.5	M36(55)
8110	TAS3081.1-300	300	485	142	M20	540	420	1030	6	32	6 - M16	270	240 g6	241	243	263	1025	770	245	5	4.5	M36(55)
8115	TAS3091-320	320	520	184	M20	490	420	1065	6	32	6 - M16	285	250 g6	251	253	273	1060	785	245	5	4.5	M36(55)

Lubrication

6-1) Shipping condition

- PARAMAX units are shipped without oil. Supply oil before operation.

6-2) Splash lubrication

In standard cases, splash lubrication is applied to horizontal PARAMAX when the high-speed shaft speed is 750-1800 rpm.

6-3) Forced lubrication

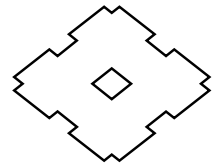
! CAUTION

- For a system in which a lubricant motor pump is provided separately, switch on the pump motor prior to switching on the reducer motor. This will enable proper lubrication of the bearings prior to start-up. Failure to do so may damage the unit.

Use a flow switch and/or sight to verify that lubricant is circulating, and for emergency motor stop if necessary.

6-4) Oil quantity

An estimated quantity of oil for standard specifications is shown in item 12. "Oil quantity." The oil quantity shown in the catalog is not exact. Use a dipstick or visible oil gauge to check the oil level.



6-5) Selection of lubricant

Refer to Table 3 to select appropriate viscosity. Table 4 shows recommended lubricants.

RECOMMENDED LUBRICANT GRADES – Table 3

Reducer Sizes	Output Speed	AGMA lubricant numbers ambient temperature C° (F°)			
		-40 to -10 (-40 to +14)	-10 to +10 (14 to 50)	10 to 35 (50 to 95)	35 to 55 (95 to 131)
8015 - 8035	To 400 RPM	3S	4	6	8
8015 - 8035	401-1100 RPM	3S	3	5	7
8045 - 8065	To 250 RPM	3S	4	6	8
8045 - 8065	251 - 750 RPM	3S	3	5	7
8075 - 8085	To 200 RPM	3S	4	6	8
8075 - 8085	201 - 550 RPM	3S	3	5	7
8090 - 8115	To 120 RPM	3S	4	6	8
8090 - 8115	121 - 350 RPM	3S	3	5	7
8120 - 8135	To 75 RPM	3S	4	6	8
8120 - 8135	76 - 225 RPM	3S	3	5	7

Table 4 Typical Products

MANUFACTURER	AGMA GRADE					
	3EP	4EP	5EP	6EP	7EP	8EP
AMOCO	Permagear EP LUB 100	Permagear EP LUB 150	Permagear EP LUB 220	Permagear EP LUB 320	Permagear EP 460	Permagear EP 680
MOBIL	Mobilgear 627	Mobilgear 629	Mobilgear 630	Mobilgear 632	Mobilgear 634	Mobilgear 636
EXXON	Spartan EP100	Spartan EP150	Spartan EP220	Spartan EP320	Spartan EP460	Spartan EP680
CHEVRON	Gear Compound EP 100	Gear Compound EP 150	Gear Compound EP 220	Gear Compound EP 320	Gear Compound EP 460	Gear Compound EP 680
SHELL	Omala 100	Omala 150	Omala 220	Omala 320	Omala 460	Omala 680
TEXACO	Meropa 100	Meropa 150	Meropa 220	Meropa 320	Meropa 460	Meropa 680
SUNOCO	—	Sunep 150	Sunep 220	Sunep 320	Sunep 460	Sunep 680

Lubricants above are typical products ONLY and should not be construed as exclusive recommendations. Synthetic alternative available upon request.

6-6) Oil supply

Supply oil through the filling port atop the main unit. Check the oil level with a dipstick or visual oil gauge (Fig. 15). Screw the dipstick to its deepest position to check the oil level; otherwise, the measured oil level will not be correct (Fig. 16).

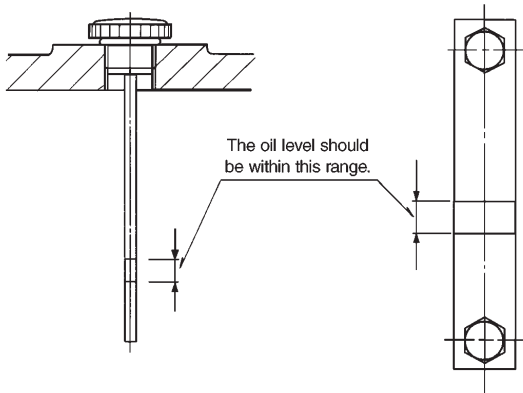


Fig. 15

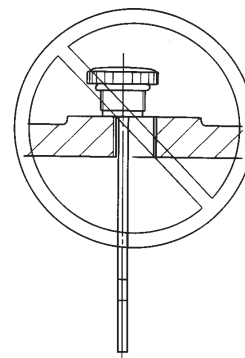


Fig. 16

Care should be maintained during the oil-filling process to ensure that loose nuts, bolts, washers, dust, water and other such foreign material do not enter the unit.

In case the oil level is lower than the range, the lubrication will be inadequate.

In case the oil level is higher than the range, deterioration of the oil is accelerated due to oil temperature rising.

6-7) Greasing

- (1) Since some bearings are grease lubricated, the location and number of grease nipples should be confirmed in advance.
- (2) The bearings are packed with grease at the time of shipment. Supply grease according to the input speed — every 1500 hours for speeds up to 750 rpm, and every 1000 hours for speeds of 750-1800 rpm.

6-8) Waste oil

Remove the drain plug under the main unit to drain waste oil while it is still warm (i.e., soon after operation of the unit has ceased, but not immediately after).

Operation

DANGER

- Never approach or touch any rotating parts (shaft, etc.) during operation. Loose clothing caught in these rotating parts may result in severe injury and/or death.

CAUTION

- The reducer will get very hot during operation. Do not touch or come in contact in any way with the reducer; otherwise, you may suffer burns.
- If the reducer is operating in an abnormal way, stop the unit immediately; otherwise, injury may result.
- Do not operate the reducer in a manner that exceeds its rating criteria; otherwise, injury or damage to the system may result.
- Do not remove any covers or open the reducer during operation; otherwise, splashing lubrication may cause burns.
- Do not loosen the oil filler plug during operation; otherwise, splashing lubricant may cause burns.
- When reversing the direction of rotation, first bring the unit to a complete stop, then commence reverse rotation; otherwise, the system may be damaged.

After installation, check the following points prior to operation.

- (1) Is the reducer correctly coupled with the mating machine?
- (2) Are foundation bolts firmly tightened?
- (3) Does the direction of rotation conform to the one specified and designed for?

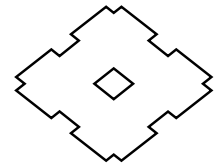
After confirming the above, allow for a no-load break-in period. Then gradually apply the design load.

At this time, confirm the following:

Table 5

Items to be checked during break-in period/possible causes.	
Abnormal sound and vibration.	<ol style="list-style-type: none"> (1) The housing is deformed because the installation surface is irregular. (2) Resonance is occurring due to the lack of rigidity of the installation base. (3) The shaft center is not properly aligned with the mating machine. (4) The vibration of the mating machine is transmitted to the reducer.
The surface temperature of the reducer is abnormally high.	<ol style="list-style-type: none"> (1) The motor current has exceeded the rated current shown in the rating plate. (2) The variable speed range of the motor is too large. (3) The ambient temperature at which the reducer is operating is too high. (4) The oil is not at its specified level (too low or too high).

When an anomaly is found, stop operation, and contact the nearest agent, dealer, or service office.



Daily Inspection and Maintenance

! DANGER

- Never approach or touch any rotating parts (shaft, etc.) when maintaining or inspecting the reducer during operation.
Loose clothing caught in these rotating parts may result in severe injury and/or death.
- Be sure to stop both the driving and driven machines before checking any tooth surfaces; otherwise, you may be caught in the gear engaging section, resulting in severe injury and/or death.
- Do not operate any units without all (safety) covers in place. Failure to do so may cause injury and/or death.

! CAUTION

- The surface of the reducer will get hot. Do not touch the reducer; otherwise, a burn may result.
- Do not change the oil during operation or soon after operation has ceased; otherwise, the hot oil may cause burns.
- Do not remove any covers or open the reducer during operation; otherwise, splashing hot lubricant may cause burns.
- Change lubricant according to the maintenance manual, and use only those recommended lubricants; otherwise, the system may be damaged.

8-1) Daily inspection

To ensure proper and continued optimum operation, use the table below to perform daily inspections of the unit.

Table 6

Inspection item	Items to be checked during break-in period/possible causes.
Noise	Is there abnormal sound or sudden change in the noise characteristics during operation?
Vibration	Is there sudden change in the vibration of the reducer? Excessive vibration?
Surface temperature	Is the temperature of the surface of the reducer abnormally high (more than 190°F)? Or is it rising rapidly? (The temperature rise during operation differs according to the type of reducer. A surface temperature of approx. 175°F will not cause any adverse effects as long as it doesn't rise significantly above this level.)
Oil level	Is the oil level decreasing? (Check the oil level with a dipstick or visible oil gauge when the reducer is not operating.)
Oil leakage	Is oil leaking from the oil seal, etc.?
Foundation bolt	Have any bolts come loose?
Chain and belt	Have any transmission belts or chains come loose?

When any anomaly is found during daily inspection, take appropriate corrective measures based on "9. Troubleshooting (p. 12)."

If normal operation is still not possible, contact the nearest agent, distributor, or service office.

8-2) Change of lubricant

- (1) Change oil 500 hours or 6 months, whichever comes first, after initial start-up. The second oil change should be after 2500 hours or 6 months, whichever comes first.
- (2) In case the oil temperature is below 160°F, a 5000 hour or 1 year (whichever comes first) change interval is recommended.
- (3) In case the oil temperature is above 160°F, a 2500 hour or 1 year (whichever comes first) change interval is recommended.
- (4) Deterioration of the oil will be accelerated when the ambient temperature changes rapidly or the ambient atmosphere contains corrosive gases. In these situations, consult with the lubricant manufacturer.

Troubleshooting

! CAUTION

- Identify and provide appropriate corrective action in a timely fashion for any abnormal operation characteristics according to the maintenance manual. Do not operate the unit until corrective action has been taken.

When any anomaly occurs in the reducer, refer to the following table and take appropriate measures as soon as possible.

Table 7

Details of trouble		Cause	Correction	
The input shaft rotates, but the output shaft will not.		Damage due to overloaded gears or shafts	Repair at a specialized workshop	
The output shaft turns when there is no load.	But it seizes up when a load is applied.	The key is out of position	Place the key in position	
		Scorched bearing	Repair at a specialized workshop	
	Reverse rotation is possible.	Poor adjustment of protective device	Adjust the protective device	
Excessive temperature rise.		Incorrect wiring for the motor	Change the connection	
		Overload	Reduce the load to the specified value	
		The ambient temperature is too high	Improve the ventilation method	
Oil leakage		Damage due to overload applied to gears, bearings, etc.	Repair at a specialized workshop	
		Oil leaks from the input/output shaft sections.	Damaged oil seal	Change the oil seal
		Scratches or abrasion of the lip contact section	Repair at a specialized workshop	
Oil leaks from the joint surface of the housing.		Loose joint bolt	Tighten the joint bolts to their proper torque	
Abnormal sound. Excessively high vibration.		Damaged gears, shafts, or bearings	Repair at a specialized workshop	
		Deformation of the housing due to uneven installation surface	Flatten the installation surface or use shims for adjustment	
		Resonance due to insufficient rigidity of installation base	Reinforce the installation base to improve the rigidity	
		Incorrect alignment with the mating machine	Align the shaft center	
		Transmission of the mating machine's vibration to the reducer	Independently operate the reducer to check the source of abnormal sound	

Disassembly/Reassembly and Disposal

10-1) Disassembly and reassembly

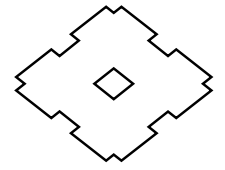
! CAUTION

- Repair, disassembly, and reassembly should be handled by properly trained technicians; otherwise, the system may be damaged.

10-2) Disposal

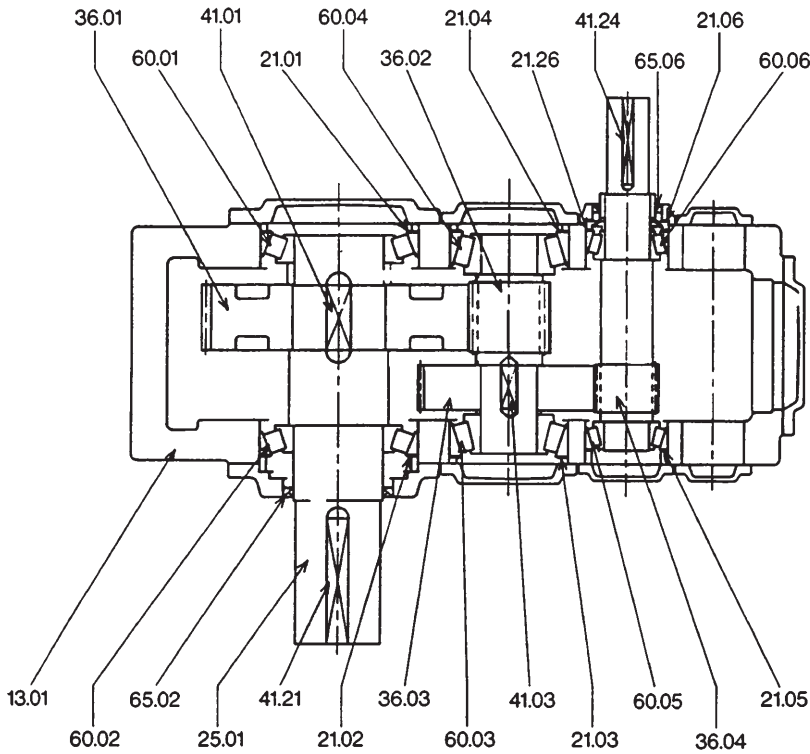
! CAUTION

- Dispose of the reducer and lubricant as general industrial waste.



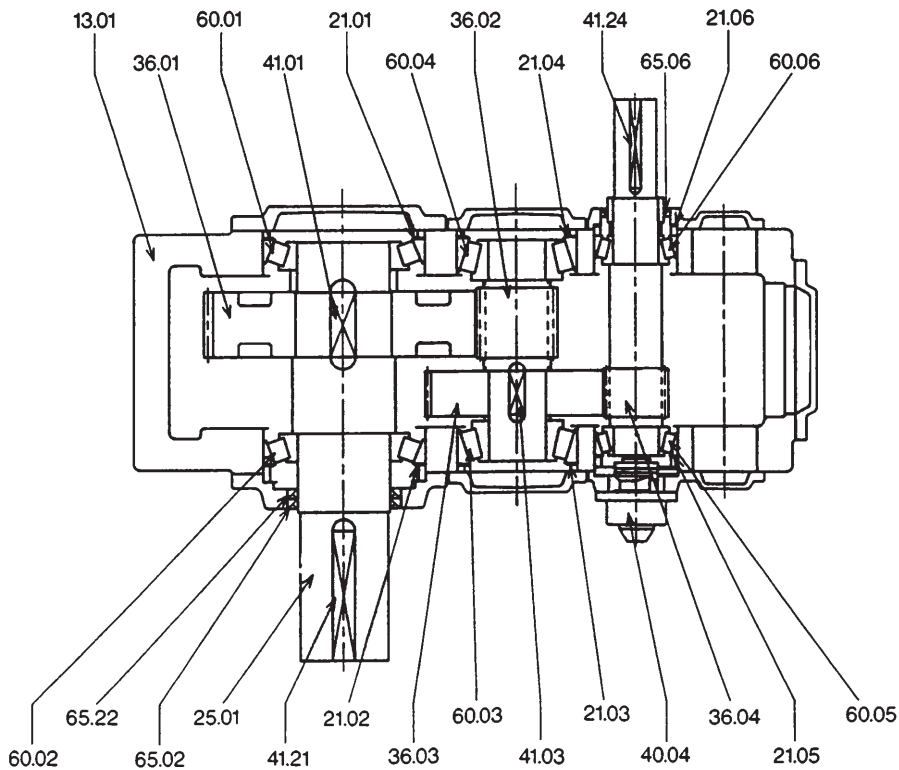
Construction Drawings

**Fig. 1 – Parallel Shaft
Horizontal – Double Reduction**

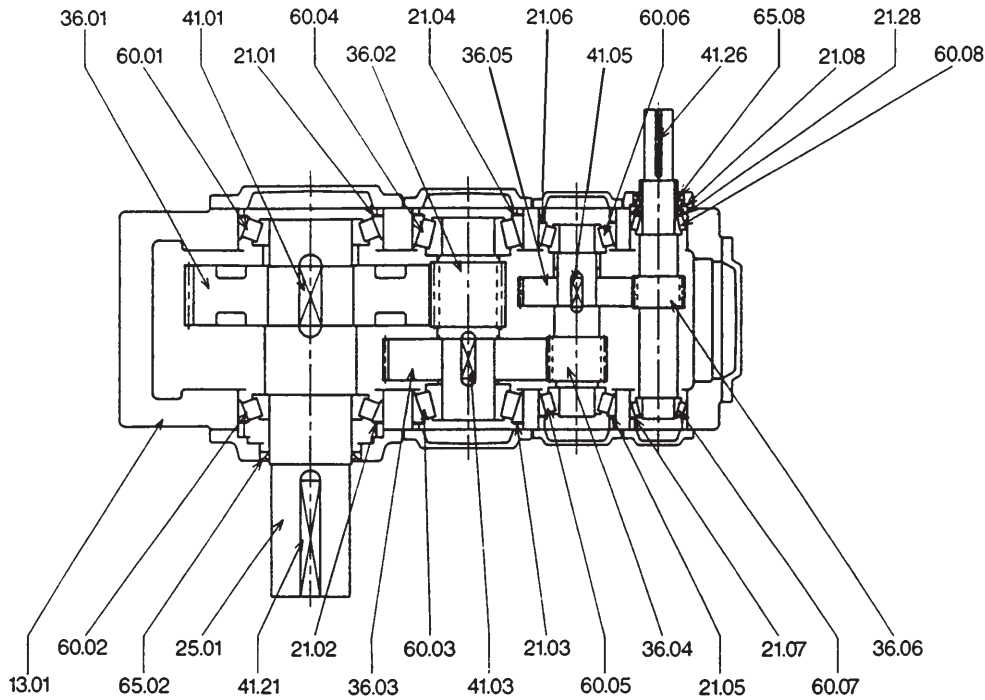


Ref. No.	Part Name
13.01	Housing
21.01	Shim
21.02	Shim
21.03	Shim
21.04	Shim
21.05	Shim
21.06	Shim
21.26	Shim
25.01	Low Speed Shaft
36.01	Helical Gear
36.02	Helical Pinion Shaft
36.03	Helical Gear
36.04	Helical Pinion Shaft
40.04	Oil Pump
41.01	Key
41.03	Key
41.21	Key
41.24	Key
60.01	Bearing
60.02	Bearing
60.03	Bearing
60.04	Bearing
60.05	Bearing
60.06	Bearing
65.02	Oil Seal
65.06	Oil Seal
65.22	Oil Seal

**Fig. 2 – Parallel Shaft
Vertical – Double Reduction**

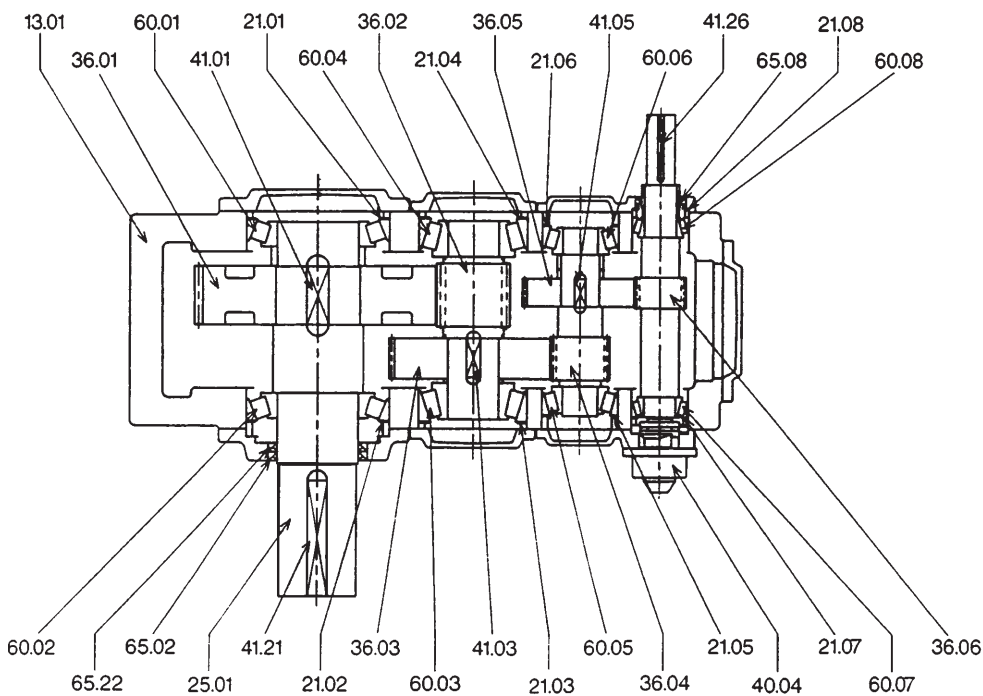


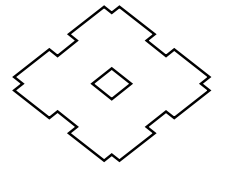
**Fig. 3 – Parallel Shaft
Horizontal – Triple Reduction**



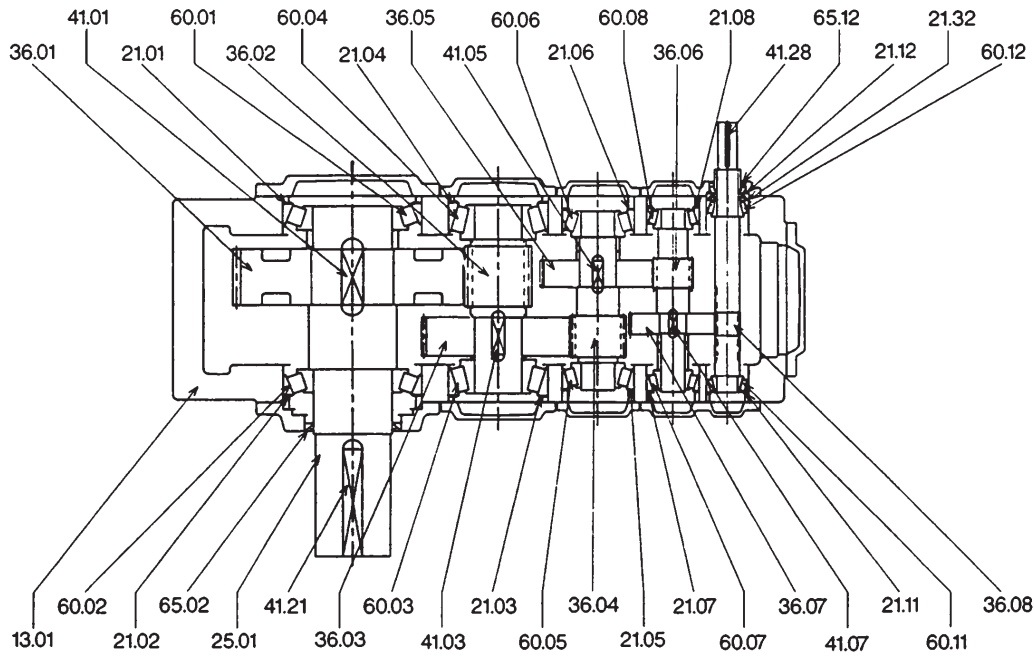
Ref. No.	Part Name
13.01	Housing
21.01	Shim
21.02	Shim
21.03	Shim
21.04	Shim
21.05	Shim
21.06	Shim
21.07	Shim
21.08	Shim
21.28	Shim
25.01	Low Speed Shaft
36.01	Helical Gear
36.02	Helical Pinion Shaft
36.03	Helical Gear
36.04	Helical Pinion Shaft
36.05	Helical Gear
36.06	Helical Pinion Shaft
40.04	Oil Pump
41.01	Key
41.03	Key
41.05	Key
41.21	Key
41.26	Key
60.01	Bearing
60.02	Bearing
60.03	Bearing
60.04	Bearing
60.05	Bearing
60.06	Bearing
60.07	Bearing
60.08	Bearing
65.02	Oil Seal
65.08	Oil Seal
65.22	Oil Seal

**Fig. 4 – Parallel Shaft
Vertical – Triple Reduction**



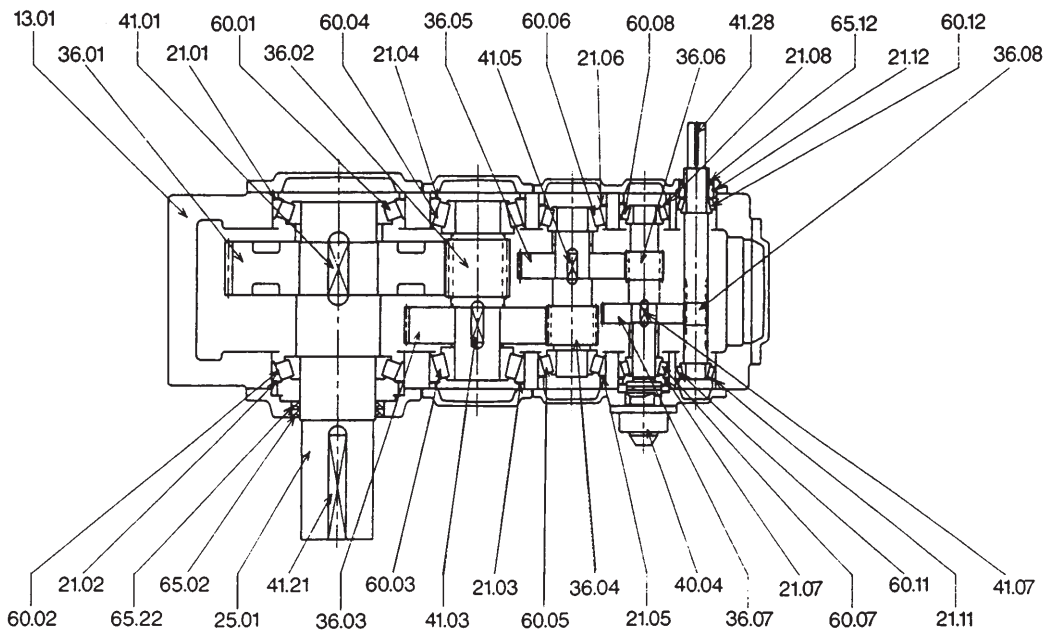


**Fig. 5 – Parallel Shaft
Horizontal – Quadruple Reduction**

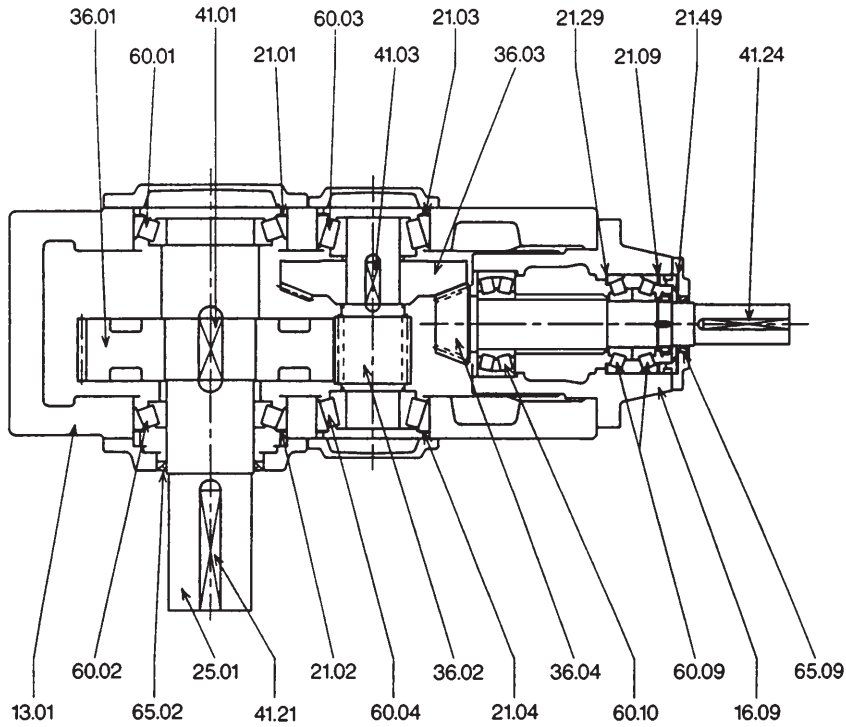


Ref. No.	Part Name
13.01	Housing
21.01	Shim
21.02	Shim
21.03	Shim
21.04	Shim
21.05	Shim
21.06	Shim
21.07	Shim
21.08	Shim
21.11	Shim
21.12	Shim
21.32	Shim
25.01	Low Speed Shaft
36.01	Helical Gear
36.02	Helical Pinion Shaft
36.03	Helical Gear
36.04	Helical Pinion Shaft
36.05	Helical Gear
36.06	Helical Pinion Shaft
36.07	Helical Gear
36.08	Helical Pinion Shaft
40.04	Oil Pump
41.01	Key
41.03	Key
41.05	Key
41.07	Key
41.21	Key
41.28	Key
60.01	Bearing
60.02	Bearing
60.03	Bearing
60.04	Bearing
60.05	Bearing
60.06	Bearing
60.07	Bearing
60.08	Bearing
60.11	Bearing
60.12	Bearing
65.02	Oil Seal
65.12	Oil Seal
65.22	Oil Seal

**Fig. 6 – Parallel Shaft
Vertical – Quadruple Reduction**

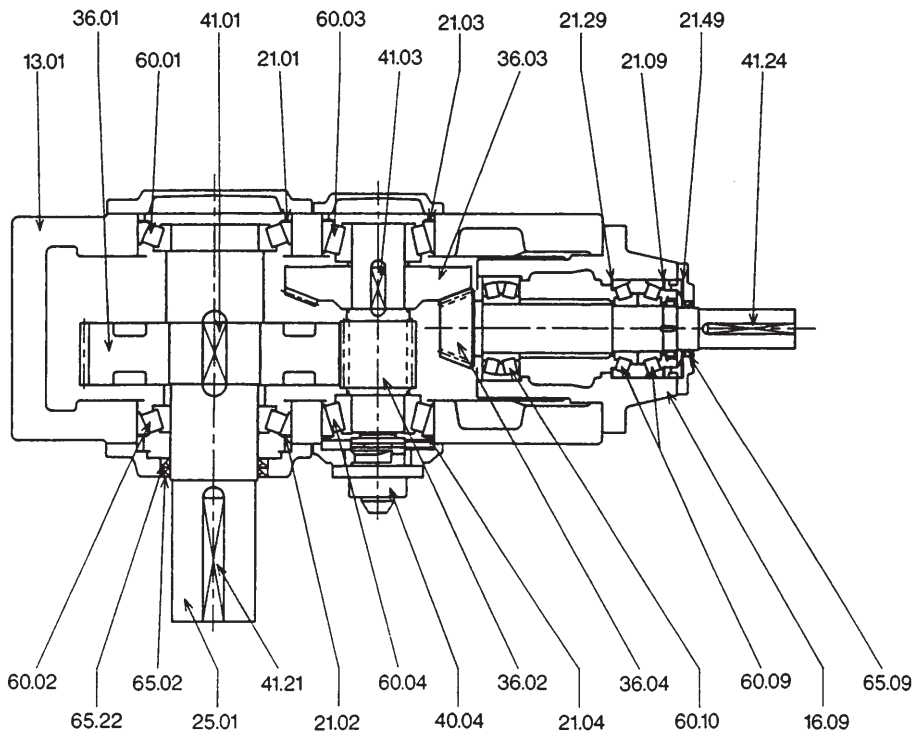


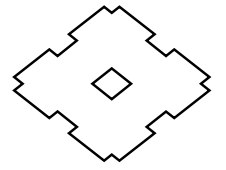
**Fig. 7 – Right Angle Shaft
Horizontal – Double Reduction**



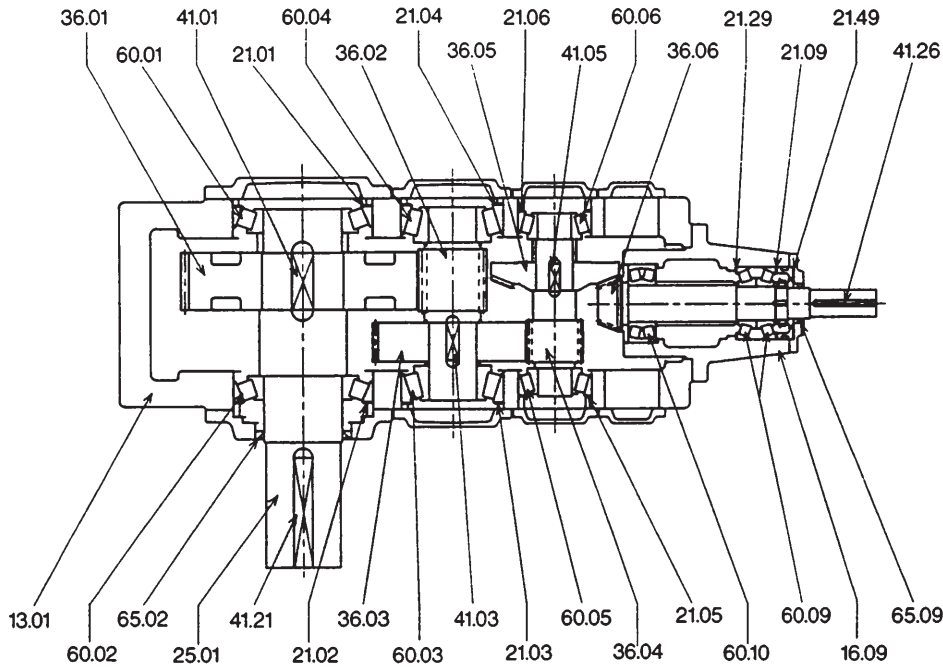
Ref. No.	Part Name
13.01	Housing
16.09	Bearing Housing
21.01	Shim
21.02	Shim
21.03	Shim
21.04	Shim
21.09	Shim
21.29	Shim
21.49	Shim
25.01	Low Speed Shaft
36.01	Helical Gear
36.02	Helical Pinion Shaft
36.03	Bevel Gear
36.04	Bevel Pinion Shaft
40.04	Oil Pump
41.01	Key
41.03	Key
41.21	Key
41.24	Key
60.01	Bearing
60.02	Bearing
60.03	Bearing
60.04	Bearing
60.09	Bearing
60.10	Bearing
65.02	Oil Seal
65.09	Oil Seal
65.22	Oil Seal

**Fig. 8 – Right Angle Shaft
Vertical – Double Reduction**



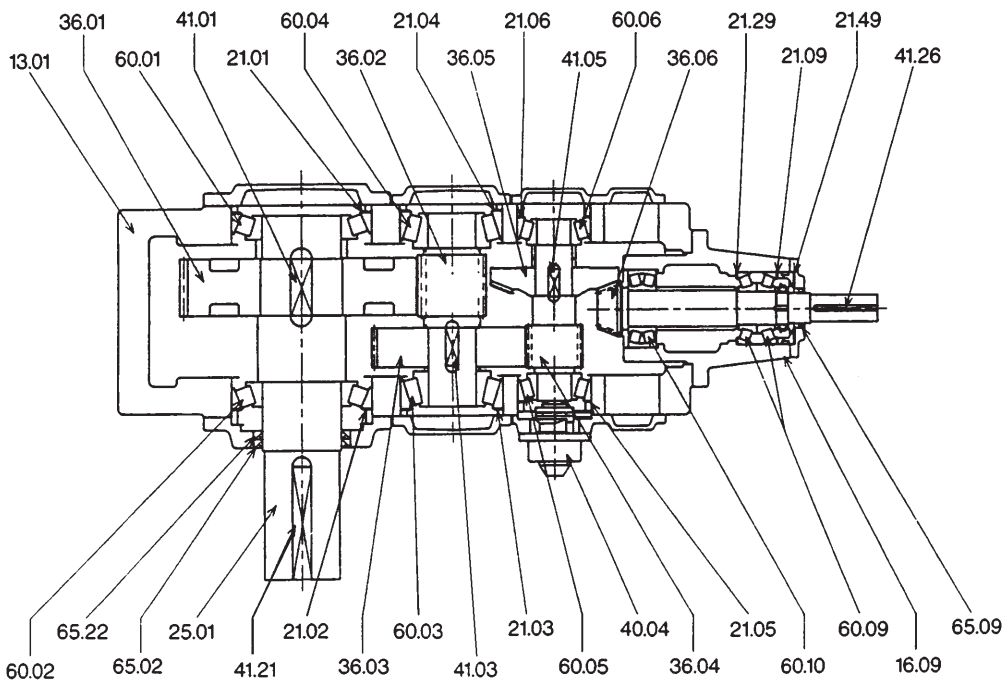


**Fig. 9 – Right Angle Shaft
Horizontal – Triple Reduction**

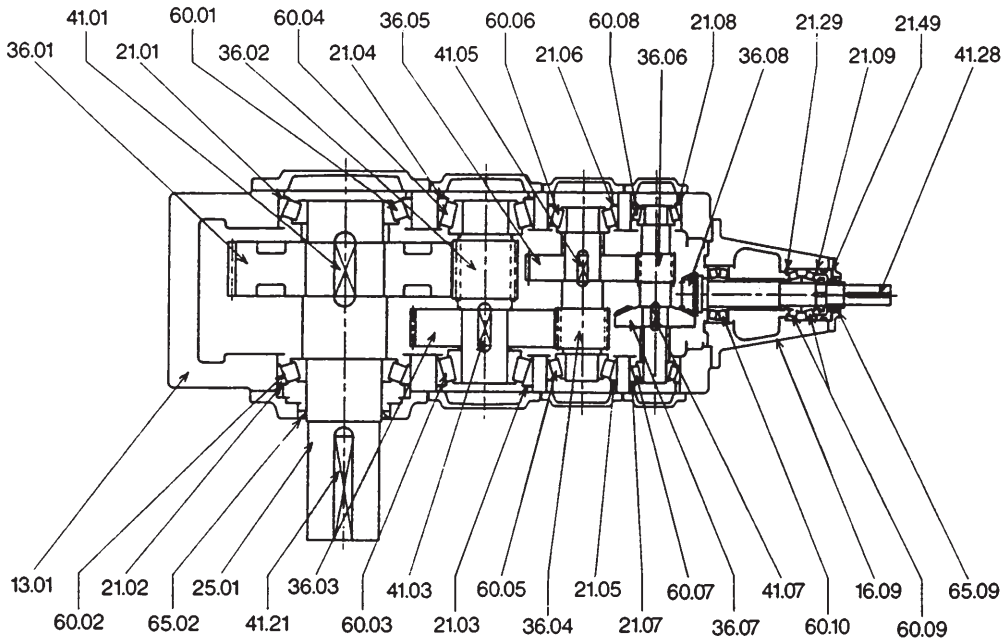


Ref. No.	Part Name
13.01	Housing
16.09	Bearing Housing
21.01	Shim
21.02	Shim
21.03	Shim
21.04	Shim
21.05	Shim
21.06	Shim
21.09	Shim
21.29	Shim
21.49	Shim
25.01	Low Speed Shaft
36.01	Helical Gear
36.02	Helical Pinion Shaft
36.03	Helical Gear
36.04	Helical Pinion Shaft
36.05	Bevel Gear
36.06	Bevel Pinion Shaft
40.04	Oil Pump
41.01	Key
41.03	Key
41.05	Key
41.21	Key
41.26	Key
60.01	Bearing
60.02	Bearing
60.03	Bearing
60.04	Bearing
60.05	Bearing
60.06	Bearing
60.09	Bearing
60.10	Bearing
65.02	Oil Seal
65.09	Oil Seal
65.22	Oil Seal

**Fig. 10 – Right Angle Shaft
Vertical – Triple Reduction**

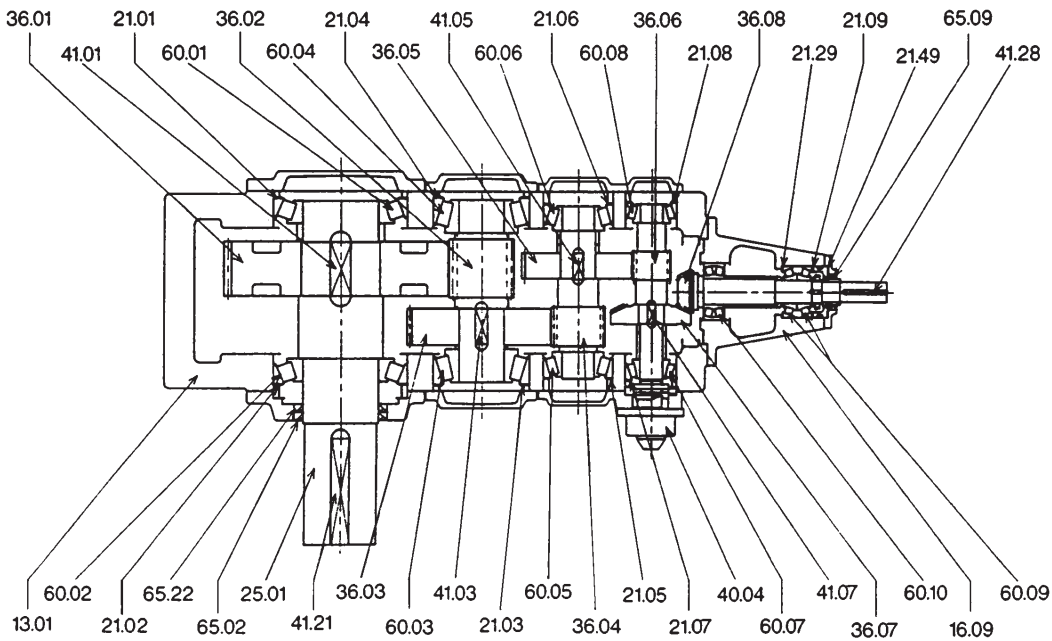


**Fig. 11 – Right Angle Shaft
Horizontal – Quadruple Reduction**



Ref. No.	Part Name
13.01	Housing
16.09	Bearing Housing
21.01	Shim
21.02	Shim
21.03	Shim
21.04	Shim
21.05	Shim
21.06	Shim
21.07	Shim
21.08	Shim
21.09	Shim
21.29	Shim
21.49	Shim
25.01	Low Speed Shaft
36.01	Helical Gear
36.02	Helical Pinion Shaft
36.03	Helical Gear
36.04	Helical Pinion Shaft
36.05	Helical Gear
36.06	Helical Pinion Shaft
36.07	Bevel Gear
36.08	Bevel Pinion Shaft
40.04	Oil Pump
41.01	Key
41.03	Key
41.05	Key
41.07	Key
41.21	Key
41.28	Key
60.01	Bearing
60.02	Bearing
60.03	Bearing
60.04	Bearing
60.05	Bearing
60.06	Bearing
60.07	Bearing
60.08	Bearing
60.09	Bearing
60.10	Bearing
65.02	Oil Seal
65.09	Oil Seal
65.22	Oil Seal

**Fig. 12 – Right Angle Shaft
Vertical – Quadruple Reduction**



Oil Quantity

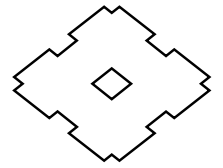


Table 8

Approximate Oil Quantity **Unit - US Gallons**

TYPE	HORIZONTAL REDUCERS						VERTICAL REDUCERS					
	Parallel Shaft			Right Angle Shaft			Parallel Shaft			Right Angle Shaft		
	P2	P3	P4	R2	R3	R4	P2	P3	P4	R2	R3	R4
8015	1.3	1.6	–	–	–	–	1.1	1.1	–	–	–	–
8025	2.1	2.1	–	–	–	–	1.6	1.6	–	–	–	–
8035	2.9	3.2	3.2	2.4	2.9	–	2.4	2.4	2.4	1.6	2.4	–
8045	4.2	4.5	4.8	3.4	4.2	5	3.4	3.4	3.2	2.1	3.7	4
8055	6.3	6.5	7.4	5.5	6.6	7.9	4.8	4.8	5	3.2	5.3	6.1
8065	9.8	11.1	11.4	8.5	10.6	12.2	7.4	7.4	8.2	5.3	8.2	9.2
8075	14.5	15.9	16.4	12.4	15.1	17.7	11.6	11.6	13.7	7.7	14	14
8085	20.9	22.7	23.8	17.7	21.9	25.6	16.4	16.1	18	9.8	18.2	19
8090	29	32	39	–	32	39	24	24	29	–	32	32
8095	37	41	48	26	41	48	29	29	34	–	36	38
8100	42	47	58	–	47	55	37	37	45	–	45	47
8105	54	59	69	39	58	67	42	42	52	–	52	54
8110	61	68	79	–	66	79	53	53	63	–	61	66
8115	77	86	96	53	82	95	62	62	73	–	71	78
8120	–	103	105	–	87	105	–	–	–	–	–	–
8125	–	103	105	–	87	105	–	–	–	–	–	–
8130	–	147	166	–	124	158	–	–	–	–	–	–
8135	–	147	166	–	124	158	–	–	–	–	–	–

Approximate Oil Quantity **Unit - Liters**

TYPE	HORIZONTAL REDUCERS						VERTICAL REDUCERS					
	Parallel Shaft			Right Angle Shaft			Parallel Shaft			Right Angle Shaft		
	P2	P3	P4	R2	R3	R4	P2	P3	P4	R2	R3	R4
8015	5	6	–	5	–	–	4	4	–	–	–	–
8025	8	8	–	7	–	–	6	6	–	–	–	–
8035	11	12	12	9	11	–	9	9	9	3	9	–
8045	16	17	18	12	16	19	13	13	12	4	14	15
8055	24	26	28	20	25	30	18	18	19	5	20	23
8065	37	42	43	28	40	46	28	28	31	7	31	35
8075	55	60	62	42	57	67	44	44	52	11	53	53
8085	79	86	90	61	83	97	63	61	68	17	69	72
8090	110	120	150	–	120	150	90	90	110	23	120	120
8095	140	155	180	100	155	180	120	120	140	28	145	155
8100	160	180	220	–	180	210	140	140	170	–	170	180
8105	205	225	260	150	220	255	175	175	210	–	210	220
8110	230	260	300	–	250	300	200	200	240	–	230	250
8115	290	325	365	200	310	360	255	255	295	–	290	315
8120	–	390	400	–	330	400	–	–	–	–	–	–
8125	–	390	400	–	330	400	–	–	–	–	–	–
8130	–	560	630	–	470	600	–	–	–	–	–	–
8135	–	560	630	–	470	600	–	–	–	–	–	–

Oil Seal Dimensions

1. For slow-speed shaft

Table 9 I.D. x O.D. x Width (Unit: mm)

SIZE	SOLID SHAFT	HOLLOW SHAFT
8015	70 x 90 x 12	80 x 100 x 12
8025	80 x 100 x 12	90 x 110 x 13
8035	90 x 110 x 13	105 x 130 x 13
8045	115 x 140 x 15	130 x 160 x 14
8055	130 x 160 x 14	140 x 170 x 14
8065	130 x 160 x 14	170 x 200 x 16
8075	150 x 180 x 14	190 x 220 x 15
8085	170 x 200 x 16	220 x 250 x 16
8090	210 x 240 x 15	240 x 270 x 15
8095	210 x 240 x 15	260 x 300 x 20
8100	220 x 250 x 16	260 x 300 x 20
8105	240 x 270 x 15	280 x 320 x 20
8110	240 x 270 x 15	300 x 340 x 20
8115	265 x 290 x 16	320 x 360 x 20
8120	280 x 320 x 20	360 x 400 x 20
8125	310 x 350 x 20	360 x 400 x 20

2. For high-speed shaft

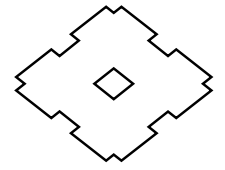
Table 10

I.D. x O.D. x Width (Unit: mm)

SIZE	PARALLEL SHAFT			RIGHT-ANGLE SHAFT		
	2-stage	3-stage	4-stage	2-stage	3-stage	4-stage
8015	40 x 52 x 8	35 x 47 x 7	—	40 x 52 x 8	—	—
8025	45 x 62 x 9	40 x 52 x 8	—	45 x 62 x 9	—	—
8035	50 x 65 x 9	40 x 52 x 8	35 x 47 x 7	50 x 65 x 9	30 x 42 x 8	—
8045	60 x 80 x 12	45 x 62 x 9	40 x 52 x 8	50 x 65 x 9	35 x 47 x 7	30 x 42 x 8
8055	70 x 90 x 12	50 x 65 x 9	40 x 52 x 8	55 x 72 x 9	40 x 52 x 8	30 x 42 x 8
8065	80 x 100 x 12	60 x 80 x 12	45 x 62 x 9	65 x 85 x 13	50 x 65 x 9	35 x 47 x 7
8075	80 x 100 x 12	70 x 90 x 12	50 x 65 x 9	70 x 90 x 12	55 x 72 x 9	40 x 52 x 8
8085	90 x 110 x 13	80 x 100 x 12	55 x 72 x 9	80 x 100 x 12	65 x 85 x 13	50 x 65 x 9
8090	100 x 120 x 12	70 x 90 x 12	55 x 72 x 9	—	70 x 90 x 12	55 x 72 x 9
8095	100 x 120 x 12	70 x 90 x 12	55 x 72 x 9	100 x 120 x 12	70 x 90 x 12	55 x 72 x 9
8100	110 x 130 x 13	80 x 100 x 12	65 x 85 x 13	—	80 x 100 x 12	65 x 85 x 13
8105	110 x 130 x 13	80 x 100 x 12	65 x 85 x 13	105 x 130 x 13	80 x 100 x 12	65 x 85 x 13
8110	125 x 150 x 13	90 x 110 x 13	65 x 85 x 13	—	90 x 110 x 13	65 x 85 x 13
8115	125 x 150 x 13	90 x 110 x 13	65 x 85 x 13	125 x 150 x 13	90 x 110 x 13	65 x 85 x 13
8120	—	110 x 130 x 13	70 x 90 x 12	—	100 x 120 x 12 *1 115 x 140 x 12	70 x 90 x 12
8125	—	110 x 130 x 13	70 x 90 x 12	—	100 x 120 x 12 *2 115 x 140 x 12	70 x 90 x 12

*1 8120 i ≤ 28

*2 8125 i ≤ 35.5



Bearings

STD: Standard bearing
HD: Heavy duty bearing

Table 11 2-stage unit bearing

	SIZE	HIGH-SPEED SHAFT		INTERMEDIATE SHAFT		SLOW-SPEED SHAFT				
		Motor side	Opposite side	Pinion side	Gear side	SOLID SHAFT		HOLLOW SHAFT		
						Shaft-out side	Opposite to shaft-out side	Shaft-out side	Opposite to shaft-out side	
2-stage parallel shaft	8015	33206	33206	33207	33207		32212	32212	*2 SL182916	*2 SL182916
	8025	33207	33207	33209	33209		33214	33214	*2 SL182918	*2 SL182918
	8035	33208	33208	32310	32310		33216	33216	*2 SL182922	*2 SL182922
	8045	33210	33210	32312	32312	STD	30219	30219	*2 SL182926	*2 SL182926
						HD	*1 22219E	*1 22219E		
	8055	33211	33211	32314	32314	STD	30222	30222	*2 SL182928	*2 SL182928
						HD	23222	23222		
	8065	33213	33213	32316	32316	STD	30226	30226	*2 SL182934	*2 SL182934
						HD	*1 22226E	*1 22226E		
	8075	33216	33216	32319	32319	STD	30230	30230	*2 SL182938	*2 SL182938
						HD	22230	22230		
	8085	33218	33218	32321	32321	STD	23134	23134	*2 SL182944	*2 SL182944
						HD	24134	24134		
	8090	2 x 30221	*1 22318E	22324	22324	STD	23136	23136	*2 SL182948	*2 SL182948
						HD	24136	24136		
8095	2 x 30221	*1 22318E	22324	22324	STD	23138	23138	*2 SL182952	*2 SL182952	
					HD	24138	24138			
8100	2 x 30224	*1 22320E	22328	22328	STD	23140	23140	*2 SL182952	*2 SL182952	
					HD	24140	24140			
8105	2 x 30224	*1 22320E	22328	22328	STD	23144	23144	*2 SL182956	*2 SL182956	
					HD	24144	24144			
8110	2 x 32032X	*1 22322E	22330	22330	STD	23144	23144	*2 SL182960	*2 SL182960	
					HD	24144	24144			
8115	2 x 32032X	*1 22322E	22330	22330	STD	23148	23148	*2 SL182964	*2 SL182964	
					HD	24148	24148			
2-stage right-angle shaft	8015	*3 2 x 30307D	*1 22308E	32307	*3 32307C		32212	32212	*2 SL182916	*2 SL182916
	8025	*3 2 x 30308D	*1 22309E	32309	*3 32309C		33214	33214	*2 SL182918	*2 SL182918
	8035	*3 2 x 30309D	*1 22310E	32310	*3 32310C		33216	33216	*2 SL182922	*2 SL182922
	8045	*3 2 x 30311D	*1 22312E	32312	*3 32312C	STD	30219	30219	*2 SL182926	*2 SL182926
						HD	*1 22219E	*1 22219E		
	8055	*3 2 x 30312D	*1 22313E	32314	*3 32314C	STD	30222	30222	*2 SL182928	*2 SL182928
						HD	23222	23222		
	8065	*3 2 x 30314D	*1 22316E	32316	*3 32316C	STD	30226	30226	*2 SL182934	*2 SL182934
						HD	*1 22226E	*1 22226E		
	8075	*3 2 x 30316D	*1 22317E	*1 22320E	*1 22320E	STD	30230	30230	*2 SL182938	*2 SL182938
						HD	22230	22230		
	8085	*3 2 x 30318D	*1 22319E	*1 22322E	*1 22322E	STD	23134	23134	*2 SL182944	*2 SL182944
						HD	24134	24134		
	8090	—	—	—	—	STD	23136	23136	*2 SL182948	*2 SL182948
						HD	24136	24136		
8095	*3 2 x 30319D	*1 22322E	22324	22324	STD	23138	23138	*2 SL182952	*2 SL182952	
					HD	24138	24138			
8100	—	—	—	—	STD	23140	23140	*2 SL182952	*2 SL182952	
					HD	24140	24140			
8105	2 x 32222	22328	22328	22328	STD	23144	23144	*2 SL182956	*2 SL182956	
					HD	24144	24144			
8110	—	—	—	—	STD	23144	23144	*2 SL182960	*2 SL182960	
					HD	24144	24144			
8115	2 x 32226	22328	22330	22330	STD	23148	23148	*2 SL182964	*2 SL182964	
					HD	24148	24148			

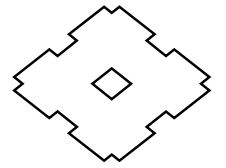
*1: E-type self-aligning roller bearing *2: Full-type roller bearing (C3 bearing internal clearance) *3: D-type and C-type taper roller bearing

STD: Standard bearing
HD: Heavy duty bearing

Table 12 3-stage unit bearing

	SIZE	HIGH-SPEED SHAFT		INTERMEDIATE SHAFT		SLOW-SPEED SHAFT						
		Motor side	Opposite side	Pinion side	Gear side	Intermediate shaft		SOLID SHAFT			HOLLOW SHAFT	
								Shaft-out side	Opposite to shaft-out side	Shaft-out side	Opposite to shaft-out side	
3-stage parallel shaft	8015	33205	33205	33206	33206	33207	33207		32212	32212	*2SL182916	*2SL182916
	8025	33206	33206	33207	33207	33209	33209		33214	33214	*2SL182918	*2SL182918
	8035	33206	33206	32307	32307	32310	32310		33216	33216	*2SL182922	*2SL182922
	8045	33207	33207	32308	32308	32312	32312	STD	30219	30219	*2SL182926	*2SL182926
								HD	*122219E	*122219E		
	8055	33208	33208	32309	32309	32314	32314	STD	30222	30222	*2SL182928	*2SL182928
								HD	23222	23222		
	8065	33210	33210	32311	32311	32316	32316	STD	30226	30226	*2SL182934	*2SL182934
								HD	*122226E	*122226E		
	8075	33211	33211	32313	32313	32319	32319	STD	30230	30230	*2SL182938	*2SL182938
								HD	22230	22230		
	8085	33213	33213	32315	32315	32321	32321	STD	23134	23134	*2SL182944	*2SL182944
								HD	24134	24134		
	8090	32314	32314	*1	*1	22324	22324	STD	23136	23136	*2SL182948	*2SL182948
				22318E	22318E			HD	24136	24136		
	8095	32314	32314	*1	*1	22324	22324	STD	23138	23138	*2SL182952	*2SL182952
22318E				22318E	HD			24138	24138			
8100	32316	32316	*1	*1	22328	22328	STD	23140	23140	*2SL182952	*2SL182952	
			22320E	22320E			HD	24140	24140			
8105	32316	32316	*1	*1	22328	22328	STD	23144	23144	*2SL182956	*2SL182956	
			22320E	22320E			HD	24144	24144			
8110	32316	32316	*1	*1	22330	22330	STD	23144	23144	*2SL182960	*2SL182960	
			22322E	22322E			HD	24144	24144			
8115	32316	32316	*1	*1	22330	22330	STD	23148	23148	*2SL182964	*2SL182964	
			22322E	22322E			HD	24148	24148			
8120	23222	23222	22326	22326	22338	22338	STD	23156	23156	*2SL182972	*2SL182972	
							HD	24156	24156			
8125	23222	23222	22326	22326	22338	22338	STD	23156	23156	*2SL182972	*2SL182972	
							HD	24156	24156			
3-stage right-angle shaft	8015	—	—	—	—	—	—					
	8025	—	—	—	—	—	—					
	8035	*3 2 x 30307D	*1 22308E	32307	32307	32310	32310		33216	33216	*2SL182922	*2SL182922
	8045	*3 2 x 30308D	*1 22309E	32308	32308	32312	32312	STD	30219	30219	*2SL182926	*2SL182926
								HD	*122219E	*122219E		
	8055	*3 2 x 30309D	*1 22310E	32309	32309	32314	32314	STD	30222	30222	*2SL182928	*2SL182928
								HD	23222	23222		
	8065	*3 2 x 30311D	*1 22312E	32311	32311	32316	32316	STD	30226	30226	*2SL182934	*2SL182934
								HD	*122226E	*122226E		
	8075	*3 2 x 30312D	*1 22313E	32313	32313	32319	32319	STD	30230	30230	*2SL182938	*2SL182938
								HD	22230	22230		
	8085	*3 2 x 30314D	*1 22315E	32315	32315	32321	32321	STD	23134	23134	*2SL182944	*2SL182944
								HD	24134	24134		
	8090	*3 2 x 30315D	*1 22316E	*1	*1	22324	22324	STD	23136	23136	*2SL182948	*2SL182948
				22318E	22318E			HD	24136	24136		
	8095	*3 2 x 30315D	*1 22316E	*1	*1	22324	22324	STD	23138	23138	*2SL182952	*2SL182952
22318E				22318E	HD			24138	24138			
8100	*3 2 x 30317D	*1 22318E	*1	*1	22328	22328	STD	23140	23140	*2SL182952	*2SL182952	
			22320E	22320E			HD	24140	24140			
8105	*3 2 x 30317D	*1 22318E	*1	*1	22328	22328	STD	23144	23144	*2SL182956	*2SL182956	
			22320E	22320E			HD	24144	24144			
8110	*3 2 x 30319D	*1 22320E	*1	*1	22330	22330	STD	23144	23144	*2SL182960	*2SL182960	
			22322E	22322E			HD	24144	24144			
8115	*3 2 x 30319D	*1 22320E	*1	*1	22330	22330	STD	23148	23148	*2SL182964	*2SL182964	
			22322E	22322E			HD	24148	24148			
8120	$i \leq 28$ 2 x 30224	22326	22328	22328	22338	22338	STD	23156	23156	*2SL182972	*2SL182972	
	*3 $i \geq 31.5$ 2 x 30319D						22322	22326	22326	HD	24156	24156
8125	$i \leq 35.5$ 2 x 30224	22326	22328	22328	22338	22338	STD	23156	23156	*2SL182972	*2SL182972	
	*3 $i \geq 40$ 2 x 30319D						22322	22326	22326	HD	24156	24156

*1: E-type self-aligning roller bearing *2: Full-type roller bearing (C3 bearing internal clearance) *3: D-type taper roller bearing



STD: Standard bearing
HD: Heavy duty bearing

Table 13 4-stage unit bearing

SIZE	HIGH-SPEED SHAFT			INTERMEDIATE SHAFT			SLOW-SPEED SHAFT					
	Motor side	Opposite side	Pinion side	Gear side	Intermediate shaft	Intermediate shaft	SOLID SHAFT			HOLLOW SHAFT		
							Shaft-out side	Opposite to shaft-out side	Shaft-out side	Opposite to shaft-out side		
8015	—	—	—	—	—	—	—	—	—	—	—	—
8025	—	—	—	—	—	—	—	—	—	—	—	—
8035	33205	33205	33206	33206	32307	32307	32310	32310	33216	33216	*2SL182922	*2SL182922
8045	33206	33206	33207	33207	32308	32308	32312	32312	STD 30219 HD *122219E	30219 *122219E	*2SL182926	*2SL182926
8055	33206	33206	32307	32307	32309	32309	32314	32314	STD 30222 HD 23222	30222 23222	*2SL182928	*2SL182928
8065	33207	33207	32308	32308	32311	32311	32316	32316	STD 30226 HD *122226E	30226 *122226E	*2SL182934	*2SL182934
8075	32308	32308	32309	32309	32313	32313	32319	32319	STD 30230 HD 22230	30230 22230	*2SL182938	*2SL182938
8085	32309	32309	32311	32311	32315	32315	32321	32321	STD 23134 HD 24134	23134 24134	*2SL182944	*2SL182944
8090	32212	32212	32314	32314	*122318E	*122318E	22324	22324	STD 23136 HD 24136	23136 24136	*2SL182948	*2SL182948
8095	32212	32212	32314	32314	*122318E	*122318E	22324	22324	STD 23138 HD 24138	23138 24138	*2SL182952	*2SL182952
8100	33214	33214	32316	32316	*122320E	*122320E	22328	22328	STD 23140 HD 24140	23140 24140	*2SL182952	*2SL182952
8105	33214	33214	32316	32316	*122320E	*122320E	22328	22328	STD 23144 HD 24144	23144 24144	*2SL182956	*2SL182956
8110	33214	33214	32316	32316	*122322E	*122322E	22330	22330	STD 23144 HD 24144	23144 24144	*2SL182960	*2SL182960
8115	33214	33214	32316	32316	*122322E	*122322E	22330	22330	STD 23148 HD 24148	23148 24148	*2SL182964	*2SL182964
8120	*122314E	*122314E	32318	32318	22326	22326	22338	22338	STD 23156 HD 24156	23156 24156	*2SL182972	*2SL182972
8125	*122314E	*122314E	32318	32318	22326	22326	22338	22338	STD 23156 HD 24056	23156 24156	*2SL182972	*2SL182972
8015	—	—	—	—	—	—	—	—	—	—	—	—
8025	—	—	—	—	—	—	—	—	—	—	—	—
8035	—	—	—	—	—	—	—	—	—	—	—	—
8045	*32x30307D	*122308E	33207	33207	32308	32308	32312	32312	STD 30219 HD *122219E	30219 *122219E	*2SL182926	*2SL182926
8055	*32x30307D	*122308E	32307	32307	32309	32309	32314	32314	STD 30222 HD 23222	30222 23222	*2SL182928	*2SL182928
8065	*32x30308D	*122309E	33208	32308	32311	32311	32316	32316	STD 30226 HD *122226E	30226 *122226E	*2SL182934	*2SL182934
8075	*32x30309D	*122310E	32309	32309	32313	32313	32319	32319	STD 30230 HD 22230	30230 22230	*2SL182938	*2SL182938
8085	*32x30311D	*122312E	32311	32311	32315	32315	32321	32321	STD 23134 HD 24134	23134 24134	*2SL182944	*2SL182944
8090	*32x30312D	*122313E	32314	32314	*122318E	*122318E	22324	22324	STD 23136 HD 24136	23136 24136	*2SL182948	*2SL182948
8095	*32x30312D	*122313E	32314	32314	*122318E	*122318E	22324	22324	STD 23138 HD 24138	23138 24138	*2SL182952	*2SL182952
8100	*32x30314D	*122315E	32316	32316	*122320E	*122320E	22328	22328	STD 23140 HD 24140	23140 24140	*2SL182952	*2SL182952
8105	*32x30314D	*122315E	32316	32316	*122320E	*122320E	22328	22328	STD 23144 HD 24144	23144 24144	*2SL182956	*2SL182956
8110	*32x30314D	*122315E	32316	32316	*122322E	*122322E	22330	22330	STD 23144 HD 24144	23144 24144	*2SL182960	*2SL182960
8115	*32x30314D	*122315E	32316	32316	*122322E	*122322E	22330	22330	STD 23148 HD 24148	23148 24148	*2SL182964	*2SL182964
8120	*32x30315D	*122316E	32318	32318	22326	22326	22338	22338	STD 23156 HD 24156	23156 24156	*2SL182972	*2SL182972
8125	*32x30315D	*122316E	32318	32318	22326	22326	22338	22338	STD 23156 HD 24156	23156 24156	*2SL182972	*2SL182972

*1: E-type self-aligning roller bearing

*2: Full-type roller bearing (C3 bearing internal clearance)

*3: D-type taper roller bearing

Locations of Oil Filler and Drain Plug

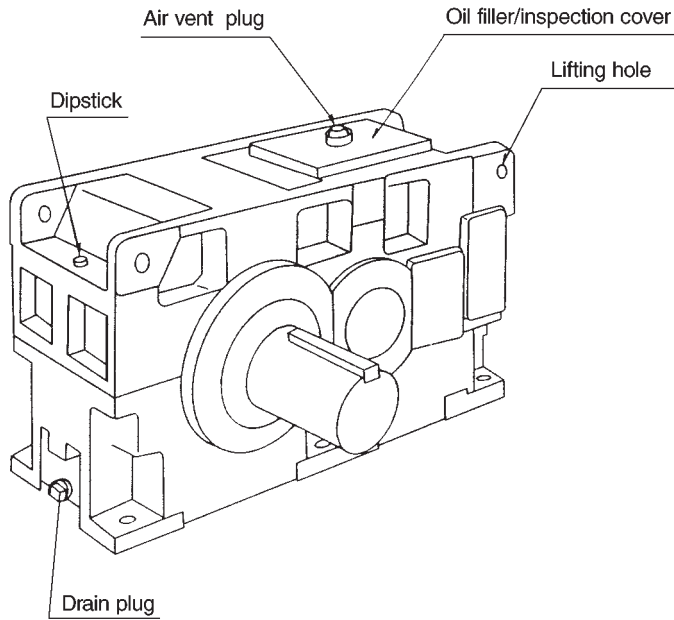


Fig. 19 Horizontal

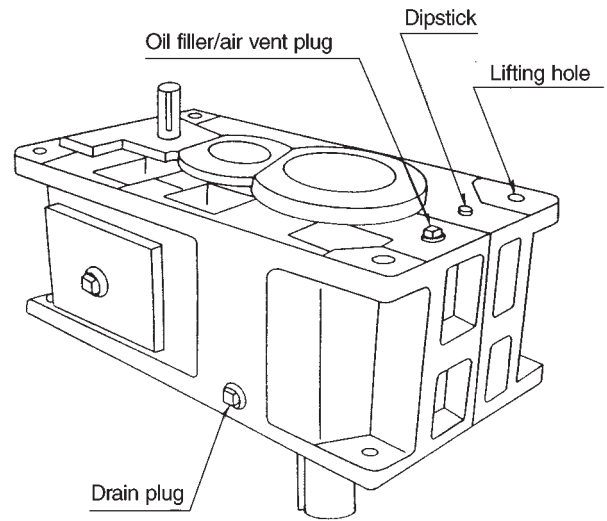


Fig. 20 Vertical

Warranty

The basic warranty for PARAMAX is as follows:

Warranty period	The warranty period of PARAMAX shall be eighteen (18) months after shipment from the factory or twelve (12) months after operation, whichever comes first, provided that PARAMAX under this warranty is new.
Items of warranty	<ol style="list-style-type: none"> 1. It is warranted that PARAMAX operates normally under the conditions for which it is installed, coupled, and maintained in conformity with the descriptions in the maintenance manual and is operated correctly according to the specifications shown in the catalog or those agreed upon separately. 2. It is warranted that parts of PARAMAX are made of proper materials and machined in accordance with established criteria, and that PARAMAX is coated, packed, and transported in accordance with established criteria. 3. It is warranted that shipped PARAMAX conforms to outline drawing and specifications. 4. The scope of warranty is limited to the scope of our manufacture. 5. The following is beyond the scope of the warranty. <ol style="list-style-type: none"> ① When PARAMAX is not properly mounted or connected to other units, resulting in nonconformance. ② When PARAMAX is not properly maintained, controlled, and handled. ③ When PARAMAX is operated without conforming to design specifications. ④ When the user of PARAMAX has altered or modified the unit in any way. ⑤ When PARAMAX is subjected to secondary failure due to the nonconformance of a unit which is connected by the user to PARAMAX. ⑥ When PARAMAX has been damaged by the use of defective parts supplied or designated by the user. ⑦ When the cause of trouble of PARAMAX arises from an earthquake, fire, flood, lightning, and other forces of nature. ⑧ When PARAMAX has been damaged due to reasons other than the above, for which Sumitomo is not responsible.

Headquarters and Manufacturing

Sumitomo Machinery Corporation of America
4200 Holland Boulevard, Chesapeake, VA 23323
(757) 485-3355 • FAX: (757) 485-3075
Toll Free: 1-800-SM-CYCLO (762-9256)
www.smcyclo.com • e-mail: smcamktg@series2000.com



North American Regional Offices Stocking & Assembly Facilities

Mid-West

175 West Lake Drive
Glendale Heights, IL 60139
(630) 752-0200 • FAX: (630) 752-0208

West

2375 Railroad Street
Corona, CA 91720
(909) 340-4100 • FAX: (909) 340-4108

Southwest

1420 Halsey Way #130
Carrollton, TX 75007
(972) 323-9600 • FAX: (972) 323-9308

Northeast

501 Office Center Dr., Suite 260
Ft. Washington, PA 19034
(215) 653-0560 • FAX: (215) 653-0181

Teterboro

7 Malcolm Avenue
Teterboro, NJ 07608
(201) 288-3366 • FAX (201) 288-8843

Southeast

4200 Holland Boulevard
Chesapeake, VA 23323
(757) 485-3355 • FAX (757) 487-3193

Canadian Stocking & Assembly Facilities

Toronto (East)

SM-CYCLO OF CANADA, LTD.
870 A Equestrian Court
Oakville, Ontario, Canada L6L 6L7
(905) 469-1050 • FAX: (905) 469-1055

British Columbia (West)

SM-CYCLO OF CANADA, LTD.
740 Chester Road, Annacis Island, Delta
B.C., Canada V3M 6J1
(604) 525-5403 • FAX: (604) 525-0879

Montreal

SM-CYCLO OF CANADA, LTD.
226 Migneron Street
St. Laurent, Quebec, Canada H4T 1Y7
(514) 340-1300 • FAX: (514) 340-1343

Mexico

Monterrey

SM-CYCLO DE MEXICO, S.A. DE C.V.
Calle "C" No. 506A
Parque Industrial Almacentro
Apodaca, N.L., Mexico 66600
011-52-8-369-3697/8 • FAX: 011-52-8-369-3699

Central & South America Sales, Engineering, Stocking & Assembly

Brazil

SM-CYCLO REDUTORES DO BRASIL LTDA.
Av. Dr. Ulysses Guimarães, 3533
09990-080 Diadema
São Paulo, Brazil
Tel.: 011-55-11-445-4388 • FAX: 011-55-11-456-2922

Chile

SM-CYCLO DE CHILE LTDA.
Napoleon 3565, Of. 510
Las Condes - Santiago, Chile
Tel.: 011-56-2-203-7300 • FAX: 011-56-2-203-7195

Australia

SM-CYCLO OF AUSTRALIA PTY LTD.
13 Centre Place
Wetherill Park, NSW 2164, Australia
Tel.: 011-61-2-9756-2455 • FAX: 011-61-2-9756-2002

Africa

South Africa

SM-CYCLO SOUTH AFRICA
P.O. Box 2808
Edenvale 1610
Gauteng, South Africa
Tel.: 011-27-11-974-3145 • FAX: 011-27-11-974-2530

India

SM-CYCLO OF INDIA PRIVATE LTD.
Khanapur Road Belgaum
590006, India
Tel.: 011-91-831-437640 • FAX: 011-91-831-421140



SPEED REDUCER



SM-CYCLO
Concentric

GEARMOTOR



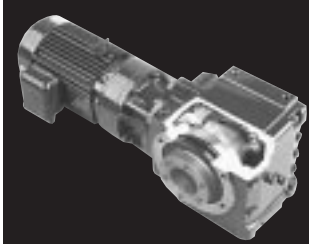
SM-CYCLO
Concentric

SHAFT MOUNTED
GEARMOTOR



SM-BUDDYBOX
Parallel Offset

BEVEL GEAR MOTOR



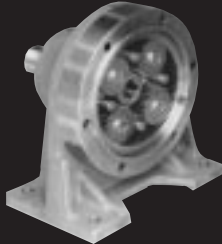
SM-BEVEL BUDDYBOX
Right Angle

WORM GEAR MOTOR



SM-WORM BUDDYBOX
Right Angle

LOW RATIO PLANETARY



SM-CYCLO
Concentric

SERVO GEAR MOTOR



SM-CYCLO
Concentric

ZERO BACKLASH CYCLO



SM-SERVO-MATCH
Concentric

MECHANICAL
VARIABLE SPEED



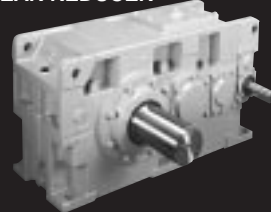
SM-BEIER
SM-BEISTER

ELECTRICAL
VARIABLE SPEED



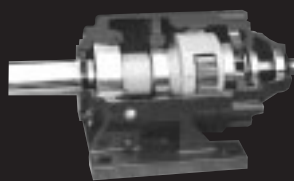
NTAC-2000 AC Drive
AF-3000 Inverter

HELICAL
GEAR REDUCER



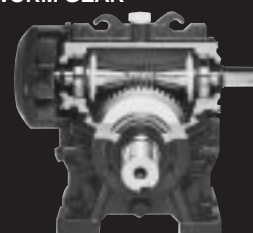
PARAMAX
Parallel Offset &
Right Angle

PLANETARY
GEAR REDUCER



SM-COMPOWER
Concentric

DOUBLE ENVELOPING
WORM GEAR



SM-HEDCON
Right Angle

HYPOID GEAR MOTOR



SM-HYPONIC
Right Angle

SUMITOMO

"QuaDelta" PROGRAM

Providing

THE AVAILABLE SOLUTION, WORLDWIDE



- ▲ GEAR BOXES
- ▲ MOTORS
- ▲ CONTROLLERS



- ▲ CONCENTRIC
- ▲ PARALLEL OFFSET
- ▲ RIGHT ANGLE



- ▲ CONSTANT SPEED
- ▲ MECHANICAL VS
- ▲ ELECTRICAL VS



- ▲ THE AMERICAS
- ▲ ASIA
- ▲ EUROPE

SUMITOMO MACHINERY CORP. OF AMERICA

Power Transmission Products

4200 Holland Blvd., Chesapeake, VA 23323

(757) 485-3355 • FAX: (757) 485-3075

Toll Free: 1-800-SM-CYCLO

Web: www.sumitomodrive.com

E-mail: marketing@suminet.com



DISTRIBUTED BY:

