

Sumitomo Drive Technologies

Sumitomo Machinery Corporation of America
Headquarters & Manufacturing
 4200 Holland Boulevard, Chesapeake, VA 23323



Sumitomo Machinery Corp. of America
 Chesapeake, VA
 Corona, CA
 Glendale Heights, IL
 Louisville, KY
 Verona, VA

Phone: +1.757.485.3355
 +1.951.340.4100
 +1.630.752.0200
 +1.502.969.0378
 +1.540.213.2442

Fax: +1.757.485.7490
 +1.951.340.4108
 +1.630.752.0208
 +1.502.969.0380
 +1.540.213.2222

SM Cyclo de Mexico, S.A. de C.V.
 Monterrey
 Guadalajara
 Ciudad de México

+52.81.8144.5130
 +52.33.3675.4323
 +52.55.2282.8700

+52.81.8144.5130 ext. 3109
 +52.33.3675.4418
 +52.55.2282.8700

SM Cyclo of Canada, Ltd.
 Toronto, ON
 Vancouver, BC

+1.905.469.1050
 +1.604.525.5403

+1.905.469.1055
 +1.604.525.0879

SM Cyclo Colombia, S.A.S.
 Bogotá

+57.1.300.0673

+57.1.300.0673 ext. 105

Sumitomo Indústrias Pesadas do Brasil Ltda.
 São Paulo

+55.11.4403.9292

+55.11.4403.9292

SM Cyclo de Chile Ltda.
 Santiago
 Antofagasta
 Concepción

+56.2.2892.7000
 +56.5.5256.1611
 +56.41.246.9806

+56.2.2892.7001
 +56.5.5256.1616
 +56.41.246.9171

SM Cyclo de Guatemala Ensambladora, Ltda.
 Guatemala

+502.6648.0500

+502.6648.9171

SM Cyclo de Argentina, SA
 Buenos Aires

+54.3327.45.4095

+54.3327.45.4099

World Headquarters

Japan
 Sumitomo Heavy Industries, Ltd.
 Power Transmission & Controls Group
 ThinkPark Tower, 1-1, Osaki 2-chome,
 Shinagawa-ku, Tokyo 141-6025 Japan
 Tel: +81-367-37-2511 • Fax: +81-368-66-5160

www.sumitomodrive.com
E-mail: Customer_Service@suminet.com

Catalog 12.001.50.008
 ©2018 Sumitomo Machinery Corporation of America Printed in USA

Sumitomo Drive Technologies

HYPONIC®

Gearmotor and Reducers

Sumitomo Drive Technologies

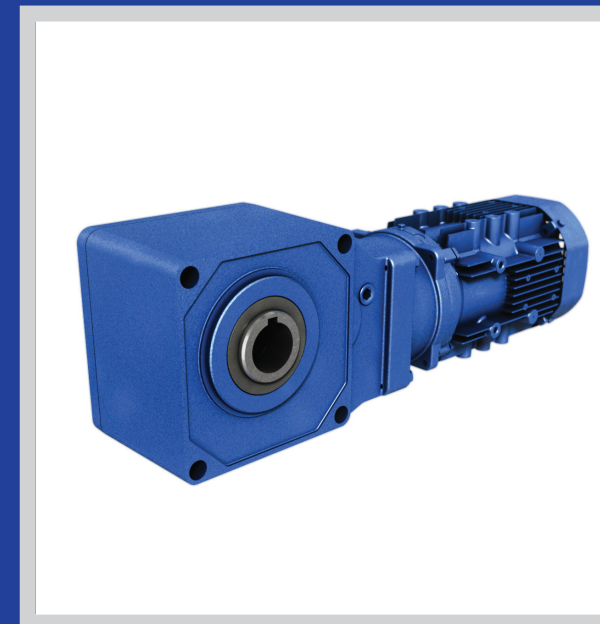

HYPONIC®
 Gearmotor and Reducers



EPNA Motors (1 HP+)

Enhanced Performance (EP,NA) integral motors represent exceptional value to customers. To maximize the performance of the motors, a host of advanced features has been developed providing tangible benefits to the users.

All in one

To simplify transactions throughout the continent, North American version (.NA) features standard multiple listings including DOE, UL and CSA, along with CE marking. Other versions are available for premium performance with European 50 Hz voltages.

Exceptionally long life

Our Premium Efficient Motors feature lower temperature rise and robust class "F" insulation. The combination of those attributes yield reduced motor operating temperatures that exponentially increase the thermal life of the insulation.

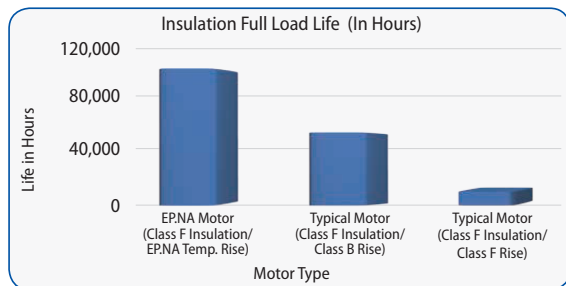

Eco friendly

Premium efficiency, mandated by the DOE, shrinks the carbon footprint by delivering more torque at the same level of energy consumption. Higher starting torques may allow smaller motors to be selected for some applications.

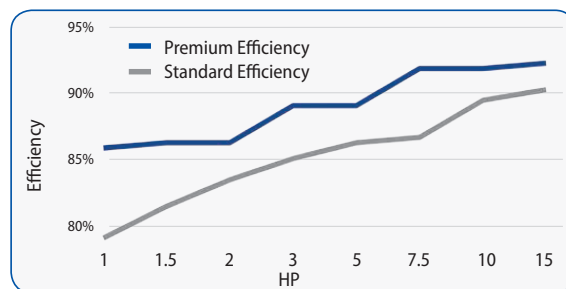

Get CAD models for Sumitomo Drive Technologies products today at www.sumitomodrive.com/Configurator

Customer_Service@suminet.com

Cost-effective

The premium efficiency design is cost-effective in reducing energy consumption throughout the full speed range, resulting in a lower total lifecycle cost.

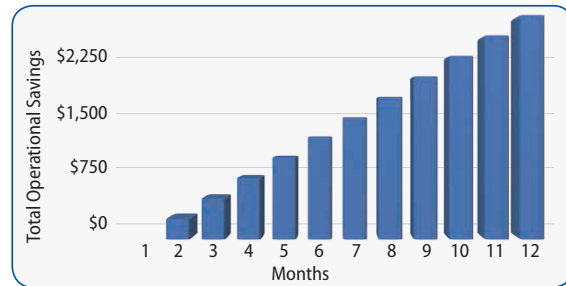

The assumptions for the study are as follows:
 9.8 cents of a dollar per kWh • 8600 operating hours annually • A 7.5 kilowatt motor (10 HP) • IE3 motor costing 25% more than the IE1 motor • IE3 premium efficiency motor being 2.8% more efficient than the IE1 standard efficiency motor

Inverter duty

All of the motors feature corona resistant magnet wire that resists the voltage spikes that are inherent to the widely applied IGBT inverters and extends insulation life. Inverter duty brake motors are also available. The non-brake motors are suitable for a 10:1 turndown. The advanced fan design helps to keep the motor running cool at lower input speeds.

Optimized Geometry

Increasing motor size is one of several techniques to reduce losses and achieve premium efficiency. Sumitomo optimized its existing external envelope while still accommodating a large motor core. The result is a compact premium efficient motor.

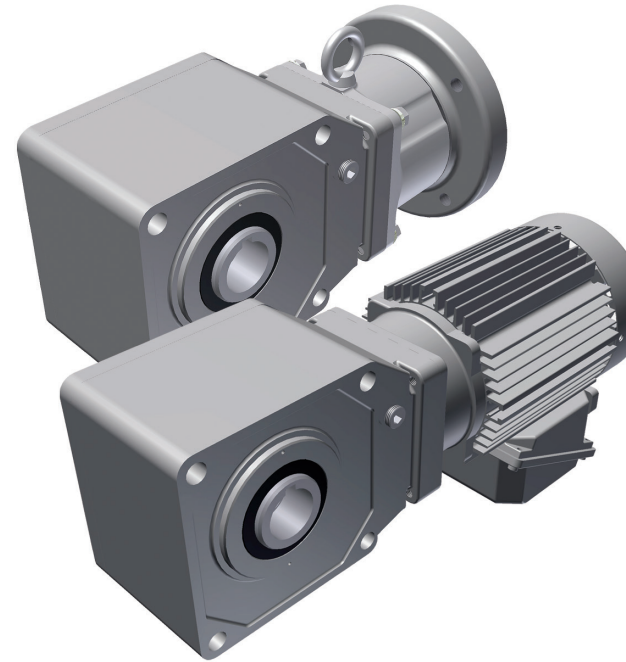
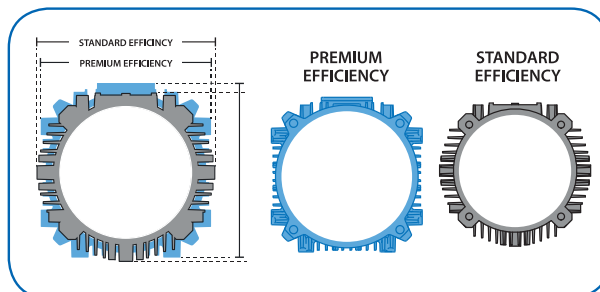

Patented, High-Performance Gearmotors and Reducers Featuring All-Steel Hypoid Gearing

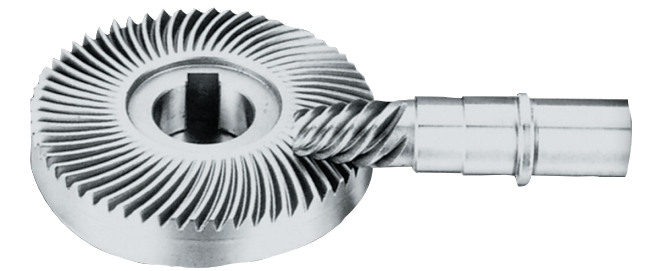

Outstanding Efficiency Saves Money

Efficiencies far higher than worm gearing. Highly efficient across all ratios. No cooling fans required.

Hyponic® hypoid gearing demonstrates efficiencies of 93% within the range of 30 to 1440:1.

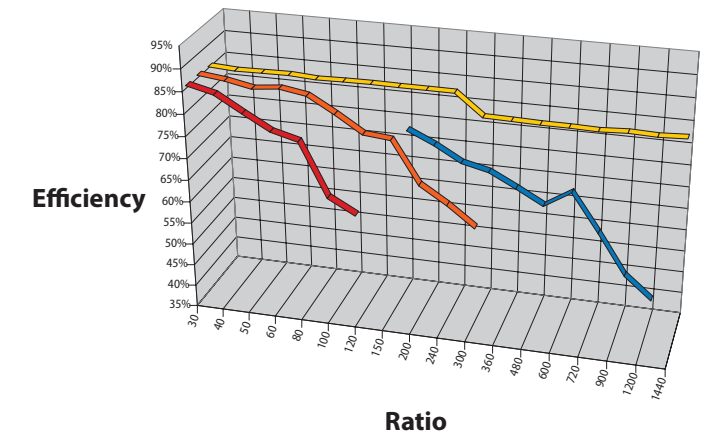

E-mail: Customer_Service@suminet.com



Product Configurator: www.sumitomodrive.com/Configurator

Sumitomo Drive Technologies' online product Configurator streamlines the selection process, enabling you to build **our power transmission products for your specific application.**

Configure your Sumitomo Drive Technologies products today at www.sumitomodrive.com/Configurator

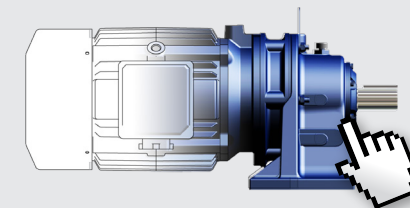

Scan with a QR code reader to login!

Table of Contents

1. General Information

2. Speed Reducers

How to Select	2.2
Configure a Model Number (Nomenclature)...	2.4
AGMA Load Classifications.....	2.6
Selection Tables	2.8
Quill Frame Sizes.....	2.8
C-Frame Sizes	2.14
Dimensions.....	2.20
Quill Frame Sizes 1100~1200	2.20
Quill Frame Sizes 1300~1400	2.22
Quill Frame Sizes 1500~1600	2.24
C-Frame Sizes 1100~1200	2.26
C-Frame Sizes 1300~1400	2.28
C-Frame Sizes 1500~1600	2.30

3. Gearmotors

How to Select	3.2
Configure a Model Number (Nomenclature)...	3.4
AGMA Load Classifications.....	3.6
Selection Tables	3.10
Three-Phase.....	3.10
Dimensions	3.36
Frame Sizes 1300 ~ 1400	3.38
Frame Sizes 1500 ~ 1600	3.42

4. Options

5. Technical Information

Exact Ratios.....	5.2
Shaft Dimensions and Rotation.....	5.7
Special Load Guidelines.....	5.8
Construction.....	5.10
Mounting.....	5.11
Accessories	5.12
Lubrication and Paint	5.14
Motor	5.16
Conduit Box Specifications	5.18
Premium Motor Data	5.20
Brakemotor Characteristics	5.32
Wiring Diagrams	5.37
Warranty.....	5.42

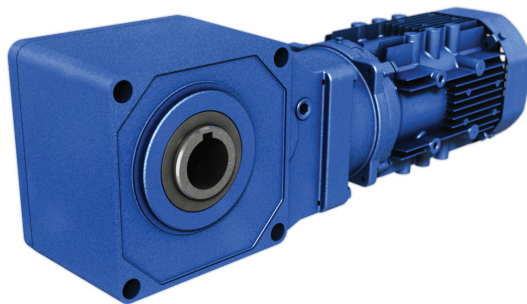

- ▶ **Grease lubricated design is maintenance free, requires no oil changes and is up to 93% gear efficiency across all ratios**

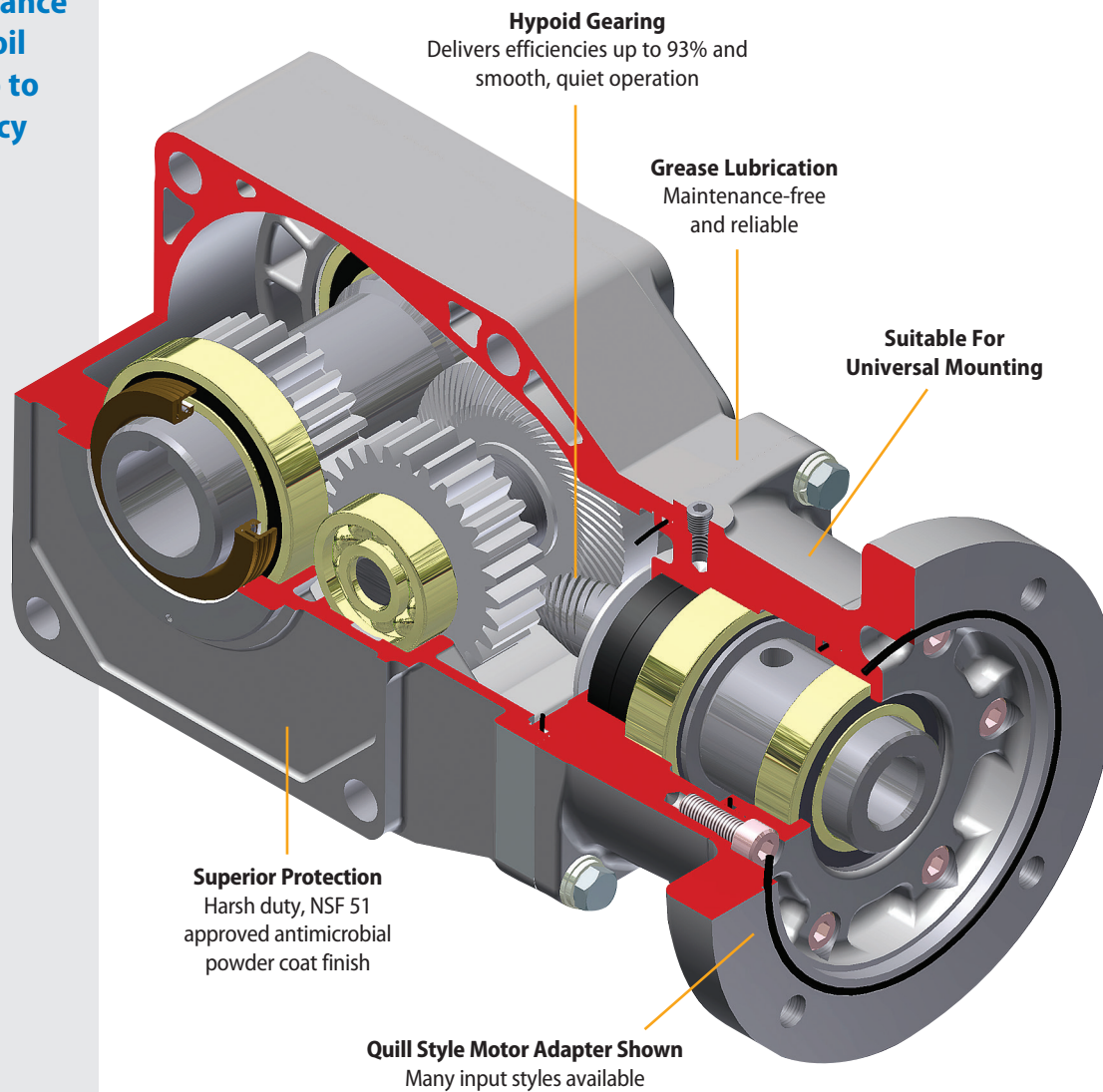

Quiet, Compact and Maintenance-Free

- ▶ **All-steel hypoid gear design transmits torque more efficiently for more torque density in a compact unit**

Product Description

The Sumitomo Hyponic® Gearmotor represents 60 years of excellence in the design and manufacture of premium gearing solutions. With millions of Hyponics currently in service, the product features a compact, modular housing, **maintenance-free grease lubrication and high efficiency operation**. Options include C-face quill design; unique FKM antimicrobial, multi-lipped rotary output seal; corrosion resistant, stainless output shaft and hardware; and synthetic NSF H-1, food-grade lubricant. NSF51 antimicrobial powder coating makes Hyponic® the ideal choice for food, beverage, and pharmaceutical industries. Sumitomo's patented, all-steel hypoid gear technology leads the industry in quiet operation and high efficiency. The Hyponic® significantly outperforms worm gearing for all ratios.

Features & Benefits

- Patented Hyponic gear technology is **up to 93% gear efficiency** across all ratios and requires no cooling fan
- **NSF 51 approved antimicrobial powder coating** protects against the growth of bacteria, mold, and fungus.
- **All-steel hypoid gear design** transmits torque more efficiently for more torque density in a compact unit
- **Maintenance-free grease lubrication** eliminates oil changes
- **Compact, lightweight** design in an aluminum, corrosion resistant housing with optional washdown protection
- Hollow bore makes **installation and retrofit quick and easy**
- **Extremely quiet**, smooth operation is ideal for commercial use
- **Two-Year warranty**
- Optional, popular keyed-hollow bore sizes available from stock: refer to page 4.9.

General Specifications Summary

Ratios:	3.5:1 up to 1440:1
HP:	1/8 to 15 HP
Maximum Torque:	13,100 in-lbs.
Electrical:	230/460 VAC (3-Phase)
Housing:	Lightweight, corrosion-resistant aluminum
Mounting:	Flange, Bolt-On Feet
Shafts:	Hollow, Solid
Input:	Quill, C-Face Adapter or Integral Motor

► Optional plug-in shaft and bolt-on feet enhance Hyponic® mounting flexibility

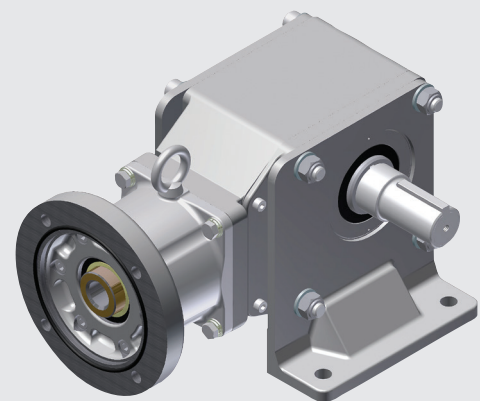
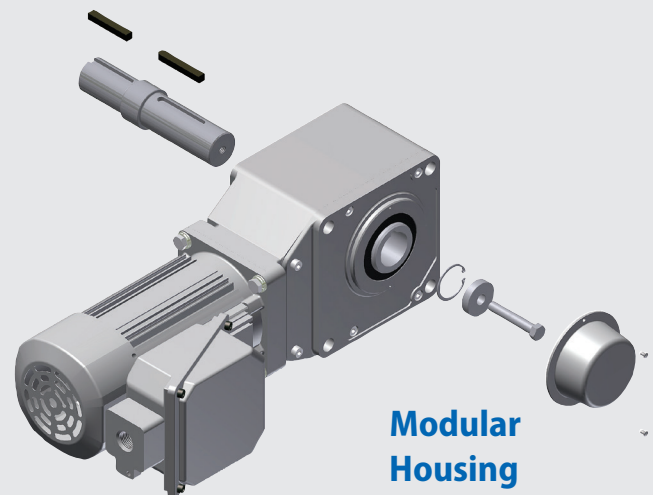

For additional Hyponic information, please visit www.sumitomodrive.com



Applications

- Bottling & Food Processing
- Commercial Bakery Lines
- Pharmaceutical Machinery
- Automotive Assembly Plants
- Conveyor Lines & Material Handling
- Residential Elevators & Lifts
- Automated Bay & Dock Door Drives
- Dehydrators
- Packaging

Product Range (Standard Motor and Reducer Combinations)

Quill Reducer Options

Frame Size	Ratio (:1)	Standard Bore* (inch)	Output Torque at 1750 RPM Input (in-lb)	Available Motor Frames
1120	5 – 60	3/4	57.5 – 246	56C
1220	5 – 60	1	115 – 492	56C
1230	80 – 120	1	328 – 492	56C
1320	5 – 30	1-1/4	230 – 985	56C – 145TC
	40 – 60		657 – 985	56C
1330	80–240	1-1/4	657 – 918	56C
1340	300 – 720	1-1/4	1160 – 1730	56C
	5 – 30		442 – 1900	145TC
1420	40 – 60	1-3/8	1310 – 1970	56C – 145TC
	80 – 240		1310 – 1840	56C
1430	80 – 240	1-3/8	1310 – 1840	56C
1440	300 – 1440	1-3/8	2320 – 3450	56C
1530	80 – 120	1-1/2	2630 – 3940	56C – 145TC
	150 – 240		2230 – 3670	56C
1531	40 – 80	1-1/2	2530 – 5060	145TC
1540	300 – 1440	1-1/2	4640 – 6480	56C
1630	10 – 120	2	903 – 11000	145TC – 184TC
1631	150 – 240	2	13100	56C – 184TC
1632	10 – 60	2	1520 – 9180	184TC
1640	300 – 720	2	9270 – 13100	56C – 145TC
	900 – 1440		13100	56C

*Optional bore sizes are available

C-Face Reducer with Jaw Coupling Options

Frame Size	Ratio (:1)	Standard Bore* (inches)	Output Torque at 1750 RPM Input (in-lb)	Available Motor Frames
1120	5 – 60	3/4	41 – 246	42C – 56C
1220	5 – 60	1	82.1 – 492	48C – 145TC
1230	80 – 240	1	328 – 867	42C – 56C
1320	5 – 60	1 1/4	164 – 985	56C – 145TC
1330	80 – 240	1 1/4	657 – 918	48C – 56C
1340	300 – 1440	1 1/4	1160 – 1730	42C – 56C
1420	5 – 60	1 3/8	316 – 1970	42C – 145TC
1430	80 – 240	1 3/8	1310 – 1840	56C
1440	300 – 1440	1 3/8	2320 – 3450	48C – 56C
1520	5 – 60	1 1/2	315 – 3790	56C – 145TC
1530	80 – 240	1 1/2	2630 – 3670	42C – 145TC
1531	40 – 80	1 1/2	2530 – 5060	56C – 184TC
1540	300 – 1440	1 1/2	4640 – 6480	56C – 145TC
1640	300 – 1440	2	9270 – 13100	56C – 145TC

*Optional bore sizes are available

Reduction Ratios 5 - 1440 Combinations with 1450 and 1750 RPM motor

		Ratio	5	7	10	12	15	20	25	30	40	50	60	80	100	120	150	200	240	300	360	480	600	720	900	1200	1440	
Actual Output RPM	50 Hz	290	207	145	121	96.7	72.5	58.0	48.3	36.3	29	24.2	18.1	14.5	12.1	9.67	7.25	6.04	4.83	4.03	3.02	2.42	2.01	1.61	1.21	1.01		
	60 Hz	350	250	175	146	117	88.0	70.0	58.0	44.0	35.0	29.0	22.0	18.0	15.0	12.0	8.80	7.30	5.80	4.90	3.70	3.10	2.30	1.90	1.46	1.22		
3-Phase	1/8 (0.1)	●	●	●	●	●	●	●	●	●	●	●	●	●	●	●	●	●	●	●	●	●	●	●	●	●	●	
	1/4 (0.2)	●	●	●	●	●	●	●	●	●	●	●	●	●	●	●	●	●	●	●	●	●	●	●	●	●	●	
	1/3 (0.25)	●	●	●	●	●	●	●	●	●	●	●	●	●	●	●	●	●	●	●	●	●	●	●	●	●	●	
	1/2 (0.4)	●	●	●	●	●	●	●	●	●	●	●	●	●	●	●	●	●	●	●	●	●	●	●	●	●	●	
	3/4 (0.55)	●	●	●	●	●	●	●	●	●	●	●	●	●	●	●	●	●	●	●	●	●	●	●	●	●	●	
	1 (0.75)	●	●	●	●	●	●	●	●	●	●	●	●	●	●	●	●	●	●	●	●	●	●	●	●	●	●	
	1.5 (1.1)	●	●	●	●	●	●	●	●	●	●	●	●	●	●	●	●	●	●	●	●	●	●	●	●	●	●	
	2 (1.5)	●	●	●	●	●	●	●	●	●	●	●	●	●	●	●	●	●	●	●	●	●	●	●	●	●	●	●
	3 (2.2)	●	●	●	●	●	●	●	●	●	●	●	●	●	●	●	●	●	●	●	●	●	●	●	●	●	●	●
	5 (3.7)	●	●	●	●	●	●	●	●	●	●	●	●	●	●	●	●	●	●	●	●	●	●	●	●	●	●	●
	7.5 (5.5)	●	●	●	●	●	●	●	●	●	●	●	●	●	●	●	●	●	●	●	●	●	●	●	●	●	●	●
	10 (7.5)	●	●	●	●	●	●	●	●	●	●	●	●	●	●	●	●	●	●	●	●	●	●	●	●	●	●	●
	15 (11)	●	●	●	●	●	●	●	●	●	●	●	●	●	●	●	●	●	●	●	●	●	●	●	●	●	●	●
	Inverter Duty	1/8 (0.1)	●	●	●	●	●	●	●	●	●	●	●	●	●	●	●	●	●	●	●	●	●	●	●	●	●	●
		1/4 (0.2)	●	●	●	●	●	●	●	●	●	●	●	●	●	●	●	●	●	●	●	●	●	●	●	●	●	●
1/3 (0.25)		●	●	●	●	●	●	●	●	●	●	●	●	●	●	●	●	●	●	●	●	●	●	●	●	●	●	
1/2 (0.4)		●	●	●	●	●	●	●	●	●	●	●	●	●	●	●	●	●	●	●	●	●	●	●	●	●	●	
3/4 (0.55)		●	●	●	●	●	●	●	●	●	●	●	●	●	●	●	●	●	●	●	●	●	●	●	●	●	●	
1 (0.75)		●	●	●	●	●	●	●	●	●	●	●	●	●	●	●	●	●	●	●	●	●	●	●	●	●	●	
1.5 (1.1)		●	●	●	●	●	●	●	●	●	●	●	●	●	●	●	●	●	●	●	●	●	●	●	●	●	●	
2 (1.5)		●	●	●	●	●	●	●	●	●	●	●	●	●	●	●	●	●	●	●	●	●	●	●	●	●	●	●
3 (2.2)		●	●	●	●	●	●	●	●	●	●	●	●	●	●	●	●	●	●	●	●	●	●	●	●	●	●	●
5 (3.7)		●	●	●	●	●	●	●	●	●	●	●	●	●	●	●	●	●	●	●	●	●	●	●	●	●	●	●
7.5 (5.5)	●	●	●	●	●	●	●	●	●	●	●	●	●	●	●	●	●	●	●	●	●	●	●	●	●	●	●	
10 (7.5)	●	●	●	●	●	●	●	●	●	●	●	●	●	●	●	●	●	●	●	●	●	●	●	●	●	●	●	

HP kW ● Standard efficiency motor
 ● Premium efficiency (EP) motor

Product Range Hollow Shaft Type

Selections shaded in blue offer an increased service factor.
Please refer to the gearmotor selection tables for specific unit service factor details.

Nominal Ratio (:1)		5	7	10	12	15	20	25	30	40	50	60
Output RPM (1750 rpm input)		350	250	175	146	117	88	70	58	44	35	29
3-Phase Input Power	1/8HP	Size 1120, Bore Ø0.75"								Size 1220, Bore Ø1.00"		
		Size 1120, Bore Ø0.75"								Size 1220, Bore Ø1.00"		
	1/4HP	Size 1220, Bore Ø1.00"								Size 1320, Bore Ø1.25"		
		Size 1220, Bore Ø1.00"								Size 1320, Bore Ø1.25"		
	1/3HP	Size 1220, Bore Ø1.00"								Size 1320, Bore Ø1.25"		
		Size 1220, Bore Ø1.00"								Size 1320, Bore Ø1.25"		
	1/2HP	Size 1320, Bore Ø1.25"								Size 1420, Bore Ø1.375"		
		Size 1320, Bore Ø1.25"								Size 1420, Bore Ø1.375"		
	3/4HP	Size 1320, Bore Ø1.25"								Size 1420, Bore Ø1.375"		
		Size 1320, Bore Ø1.25"								Size 1420, Bore Ø1.375"		
	1HP	Size 1420, Bore Ø1.375"								Size 1520, Bore Ø1.50"		
		Size 1420, Bore Ø1.375"								Size 1520, Bore Ø1.50"		
	1.5HP	Size 1420, Bore Ø1.375"								Size 1520, Bore Ø1.50"		
		Size 1420, Bore Ø1.375"								Size 1520, Bore Ø1.50"		
	2HP	Size 1420, Bore Ø1.375"								Size 1520, Bore Ø1.50"		
Size 1520, Bore Ø1.50"								Size 1531, Bore Ø1.50"				
3HP	Size 1520, Bore Ø1.50"								Size 1531, Bore Ø1.50"			
	Size 1521, Bore Ø1.50"					Size 1632, Bore Ø2.00"			Size 1632, Bore Ø2.00"			
5HP	Size 1521, Bore Ø1.50"					Size 1632, Bore Ø2.00"			Size 1632, Bore Ø2.00"			
	Size 1522, Bore Ø1.50"					Size 1633, Bore Ø2.00"			Size 1633, Bore Ø2.00"			
7.5HP	Size 1522, Bore Ø1.50"					Size 1633, Bore Ø2.00"			Size 1633, Bore Ø2.00"			
	Size 1634, Bore Ø2.00"					Size 1634, Bore Ø2.00"			Size 1634, Bore Ø2.00"			
10HP	Size 1634, Bore Ø2.00"					Size 1634, Bore Ø2.00"			Size 1634, Bore Ø2.00"			
	Size 1634, Bore Ø2.00"					Size 1634, Bore Ø2.00"			Size 1634, Bore Ø2.00"			
15HP	Size 1634, Bore Ø2.00"					Size 1634, Bore Ø2.00"			Size 1634, Bore Ø2.00"			

...table continued on next page.

Product Range continued

80	100	120	150	200	240	300	360	480	600	720	900	1200	1440
22	17.5	14.6	11.7	8.8	7.3	5.8	4.9	3.7	2.9	2.4	1.9	1.5	1.2
Size 1230, Bore Ø1.00" ^[1]						Size 1340, Bore Ø1.25" ^[1]							
Size 1330, Bore Ø1.25"						Size 1440, Bore Ø1.375" ^[1]							
Size 1330, Bore Ø1.25" ^[1]						Size 1440, Bore Ø1.375" ^[1]							
Size 1430, Bore Ø1.375"						Size 1540, Bore Ø1.50" ^[1]							
Size 1430, Bore Ø1.375"						Size 1540, Bore Ø1.50" ^[1]							
Size 1430, Bore Ø1.375" ^[1]						Size 1540, Bore Ø1.50" ^[1]							
Size 1530, Bore Ø1.375"						Size 1640, Bore Ø2.00" ^[1]							
Size 1530, Bore Ø1.375"						Size 1640, Bore Ø2.00" ^[1]							
Size 1530, Bore Ø1.375"						Size 1640, Bore Ø2.00" ^[1]							
Size 1531 Bore Ø1.50"	Size 1630, Bore Ø2.00"		Size 1631, Bore Ø2.00"										
Size 1531 Bore Ø1.50"	Size 1630, Bore Ø2.00"		Size 1631, Bore Ø2.00"										
Size 1531 Bore Ø1.50"	Size 1630, Bore Ø2.00"		Size 1631, Bore Ø2.00" ^[1]										
Size 1630, Bore Ø2.00"			Size 1631, Bore Ø2.00" ^[1]										

Note: [1] This frame size is torque limited. Overload may occur if the motor is loaded to its full capacity. Sumitomo recommends the use of a torque limiting device to protect the unit and/or the driven machine.

FAQs

How do I select a Hyponic® speed reducer or gearmotor?

Selection is based on the actual horsepower and/or torque requirements at the output shaft. The Hyponic® speed reducer has particularly high efficiencies over a wide range of reduction ratios, which frequently permits the use of reduced input power requirements (smaller HP or kW motor) without sacrificing output shaft torque. The selection procedures in this catalog will guide you in choosing the most efficient reducer for your application.

What information do I need to get started in the selection process?

To select the proper reducer for your application, you will need to know:

- Application: type of driven machine
- Hours of operation per day
- Motor power (HP or kW) and speed (RPM)
- Mounting position
- Environmental conditions
- Ambient temperature range

If there are any special environmental factors or operation requirements, then they must also be noted. This information will be important in determining the Service Factor of your application.

What are Service Factors and how are they used?

In general, reducers are rated for the specific conditions and operating requirements of the application by the use of AGMA-defined Service Factors. The AGMA Load Classifications table on page 2.6 classifies applications by the type of load to help users to apply the correct service factors shown on page 2.3. The Service Factors are used in the product selection process to adjust for the specific conditions and operating requirements of your application.

What do I do if my application has particularly severe operating conditions?

The standard ratings for Hyponic® are based on 10-hour daily service under conditions of uniform loads (equivalent to AGMA service factor 1.0). By following the product selection process, you will determine and apply the Service Factors to compensate for the severe operating conditions.

What are the advantages of a shrink disc?

The shrink disc provides for easy mounting and removal to and from the shaft of the driven machine. Because it requires no keyway, the shaft isn't weakened and maximum torque is transmitted.

What kind of torque arm do I specify?

The standard torque arm is shown on page 4.8. The Hyponic® gearbox does not ship with a torque arm unless customer specifies.

Can the Hyponic be mounted in any position?

All frame sizes come standard grease lubricated and can be mounted in any position. Food-grade grease and oil lubrication is available upon customer request.

Enhanced Performance (EP) Motors FAQs (1HP+)

What efficiency level are these Enhanced Performance (EP) motors?

The EP motor (applies to 1HP and above) is a Premium efficiency class, or International Efficiency 3 (IE3) design. Our integral fractional (less than 1HP) motors are not EP and are classified as standard efficiency IE1 motors.

What standards do these motors meet?

All Sumitomo motors are compliant with the Energy Policy and Conservation Act (EPAAct), as recently amended by the Department of Energy with a new ruling.

EP Sumitomo motors met the efficiency levels promoted by the Consortium for Energy Efficiency (CEE) and meet the Canadian efficiency levels specified by NRCan.

The IE3 efficiency ratings conform to both the IEC Standard 60034-30:2009 and eco-design directive 2005/32/EC.

Will Sumitomo motors work with inverters?

All current EP motors feature corona resistant magnet wire that extends the life of the insulation and enables the motors to resist the voltage spikes common with IGBT variable frequency drives.

What agency listings apply?

All EP motors in this product line are UL recognized, CSA certified and CE marked.

Can the motor be nameplated to operate at 50 hertz?

The motor can be nameplated and will operate at 50 hertz, but depending on the export destination, it may not meet that country's energy efficiency requirements. For areas requiring IE3 performance at 50 hertz, like Asia and Europe, other 50 hertz specific versions can be provided. Conformance with energy efficiency requirements in destination country is the responsibility of the customer.

Is the selection procedure the same as previous gearmotors?

Similar, the difference is restricted to applications with a large number of across the line starts and stops. Because the EP motors have more inertia and higher inrush current than previous integral motors, a supplemental service factor is applied to these applications using EP motors. The selection procedure for fractional HP units is unchanged.

Are the brakes the same?

The brakes are the same direct acting, fast response types used previously. For motors 1 HP and above they are a new larger model that has been redesigned to match the new motor profiles. Because the EP motor inertia is significantly higher, it may be necessary to adjust external trigger points or limit switches. Since the brake assembly shapes are different, old and new kits are not interchangeable.

What is the standard insulation system?

The motors continue with the Class F system, which limits the temperature rise to a Class B rise, where it bounds the allowable temperature rise to 80°C. It utilizes an insulation system capable of handling a 105°C rise to significantly extend insulation life.

Are EP motors interchangeable with old AF-motors?

The new EP motors without brake have the same 10:1 constant torque speed range as the AF-motor. Motors are dimensionally and performance-wise different so VFD re-programming may be required. For EP brakemotor with use on VFDs, the applicable speed range may be limited. Please consult the factory for options for EP brakemotors.

Will non-HP motors continue to be available?

For motor powers 1 HP and above, EP motors have replaced the standard efficiency motors. (does not apply to fractional HP). 1HP+ Older motors do not meet the federally mandated efficiency requirements that went into effect on June 1, 2016. Non-compliant motors cannot be manufactured or imported into the United States.

Should I be concerned if I am replacing a non-EP motor with the new EP motor?

For most applications, the use of the new EP motor will result in a more efficient, cooler-running and energy-saving motor. However, for applications with certain performance constraints, you may need to review the impact of the following:

- larger dimension and weight
- larger moment of inertia
- higher starting current and torque.

If taking a standard efficiency motor off a gearmotor and replacing it with the same HP new EP motor, the EP motor will bolt to the non-EP gearmotor. The motor flange diameters, pilot diameters, bolt patterns and shaft diameters all match. Motor body dimensions and weight will change.

Standard Specifications

	Standard Specifications	Standard Specifications with Built-In Brake	
3 Phase Integral Motor Fractional HP Motor	Capacity Range	1/8 through 3/4 HP (4 pole)	1/8 through 3/4 HP (4 pole)
	Power Supply	Motor Power: 230 / 460V, 60 Hz, 3 Phase 575V, 60 Hz, 3 Phase	Motor Power: 230 / 460V, 60 Hz, 3 Phase 575V, 60 Hz, 3 Phase Brake Power: 230 / 460V, 60 Hz, 1 Phase 575V, 60 Hz, 1 Phase
	Motor Standard	NEMA	NEMA
	Efficiency	Standard Efficiency (IE1)	Standard Efficiency (IE1)
	Protection	IP55	IP55
	Certification	CE Mark, UL Recognition, CSA Approval	CE Mark, UL Recognition, CSA Approval
	Conduit Box	Diecast Aluminum, NPT Conduit Thread	Diecast Aluminum, NPT Conduit Thread
3 Phase Integral EP.NA Motor	Capacity Range	1 through 15 HP (4 pole)	1 through 15 HP (4 pole)
	Power Supply	Motor Power: 230 / 460V, 60 Hz, 3 Phase 575V, 60 Hz, 3 Phase	Motor Power: 230 / 460V, 60 Hz, 3 Phase 575V, 60 Hz, 3 Phase Brake Power: 230 / 460V, 60 Hz, 1 Phase 575V, 60 Hz, 1 Phase
	Motor Standard	NEMA	NEMA
	Efficiency	Premium Efficiency (IE3)	Premium Efficiency (IE3)
	Protection	IP55	IP55
	Certification	CE Mark, UL Recognition, CSA Approval	CE Mark, UL Recognition, CSA Approval
	Conduit Box	Diecast Aluminum, NPT Conduit Thread	Diecast Aluminum, NPT Conduit Thread
3 Phase Integral IE3 CE Motor	Capacity Range	0.75 through 11.0 kW (4 pole)	0.75 through 11.0 kW (4 pole)
	Power Supply	Motor Power (0.75 through 4.0 kW) 230 / 400V, 50 Hz, 3 Phase (5.5 through 11.0 kW) 400V, 50 Hz, 3 Phase	Motor Power (0.75 through 4.0 kW) 230 / 400V, 50 Hz, 3 Phase (5.5 through 11.0 kW) 400V, 50 Hz, 3 Phase Brake Power (0.75 through 4.0 kW) 220 - 240V, 50 Hz, 1 Phase (5.5 through 11.0 kW) 380 - 415V, 50 Hz, 1 Phase
	Motor Standard	IEC	IEC
	Efficiency	IE3	IE3
	Protection	IP55	IP44
	Certification	CE Mark	CE Mark
	Conduit Box	Diecast Aluminum, Metric Conduit Thread	Diecast Aluminum, Metric Conduit Thread
3 Phase Integral Motor - Common	Enclosure	Totally Enclosed Fan Cooled (TEFC) 1/8 HP - Totally Enclosed Non-Ventilated (TENV)	Totally Enclosed Fan Cooled (TEFC) 1/8 HP - Totally Enclosed Non-Ventilated (TENV)
	Motor Type	Asynchronous Induction Motor, Squirrel Cage Rotor	Asynchronous Induction Motor, Squirrel Cage Rotor
	Frame Material	Diecast Aluminum	Diecast Aluminum
	Bearings	Double Shielded, Deep Groove, Ball Bearing, CM Clearance	Double Shielded, Deep Groove, Ball Bearing, CM Clearance
	Insulation	Class F	Class F - Motor and Brake
	Time Rating	Continuous	Continuous
	Hyponic®	Reduction	Combination of hypoid gear input and involute gear output.
Lubrication		Grease lubricated; filled with special high-grade grease prior to shipment.	
Seals		Nitrile material, triple or double lipped output seals. Input seals are FKH.	
Material		Casing: aluminum alloy or cast iron; Gear: chrome-molybdenum steel	
Paint Color		Blue, Munsell color number 6.5PB 3.6/8.2 or Silver.	
Bearings		Deep groove ball bearings on input and output	
Ambient Conditions	Installation Location	Indoor (Minimal dust and humidity)	
	Ambient Temperature	14° ~ 104° F (-10° ~ 40° C)	
	Ambient Humidity	Under 85%	
	Elevation	Under 3300 feet (1000 meters)	
	Atmosphere	Well ventilated location, free of corrosive gases, explosive gases, vapors, and dust	

2

Speed Reducers

Hollow Shaft Type

Speed Reducers

How to Select

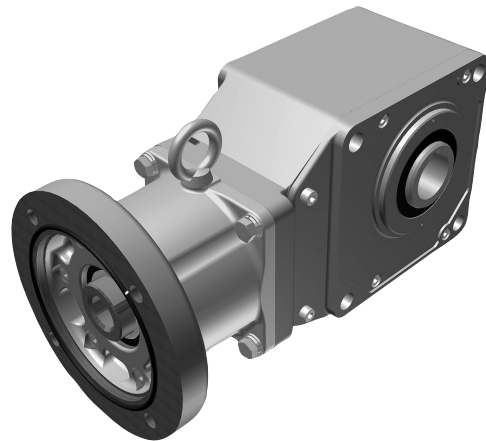

How to select a Speed Reducer

Step 1: Collect data about your application

Before starting you need to know the:

- Application (e.g. Conveyor, Mixer, etc.)
- Hours of Operation per day
- Motor Horsepower (HP) and Speed (RPM)
- Desired Output Speed
- Mounting Position and Style
- Overhung or Thrust Loads
- Bore Dimensions, inch or metric
- Ambient Conditions

Step 2: Select a Frame Size

2A: Find the Load Classification of your application in the AGMA Load Classification Tables on pages 2.6. If the Hyponic® Reducer will be used in a frequent starts and stops application and the motor will be operated across the line, please refer to Method B on page 3.6.

2B: Find the recommended Service Factor using the Recommended Reducer Service Factor Table on the next page. For Recommended Service Factors for Frequent Start/Stop Applications, consult table on page 3.6.

2C: Determine the Selection Horsepower by multiplying the Motor Horsepower by the Service Factor.

2D: Select a Frame size from the Reducer Selection Tables on pages 2.8–2.18 by matching both the Selection Horsepower and Desired Output Speed (RPMs) to a frame size model number.

Step 3: Verify Dimensions

Use the Dimensions information on pages 2.20–2.31 to verify that the selected Frame Size is appropriate.

Step 4: Choose Options

The following options may apply:

- Solid Shaft
- Mounting Feet
- Output Flange
- Torque Arm Assembly
- Washdown Modification

Refer to Section 4 of this catalog for dimension drawings of selected popular options .

Step 5: Configure a Model Number

Go to page 2.4 to configure a model number.

Note: You will use the information you gather from the procedure on this page to configure a model Number.

For additional options, please visit our configurator at: www.sumitomodrive.com/configurator

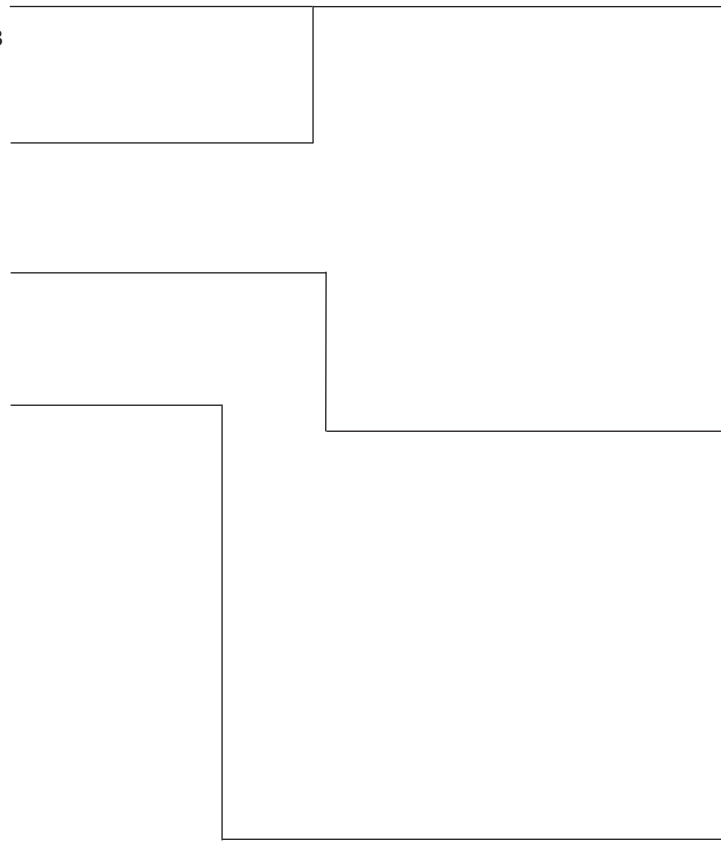

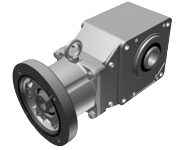

Recommended Reducer Service Factors

		AGMA Load Classifications		
		Uniform (U)	Moderate Shock (M)	Heavy Shock (H)
Duration of Service	1/2 hr. per day (Occasional)	0.50 ^[1]	0.80 ^[1]	1.25
	3 hrs. per day (Intermittent)	0.80	1.00	1.50
	Up to 10 hrs. per day	1.00	1.25	1.75
	24 hrs. per day	1.25	1.50	2.00

Note: [1] Maximum momentary or starting load must not exceed 300% of gear reducer rating (rating meaning service factor of 1.0). Time specified for occasional and intermittent service refers to total operating time per day.

Speed Reducers

How to Select

Determine Selection Horsepower (HP)

$$\text{Motor HP} \times \text{Service Factor} = \text{Selection HP}$$

Example: 10 Motor HP X 1.25 Service Factor = 12.5 Selection HP

Select a Frame Size

1 Match your OUTPUT RPM (or RATIO)...

Output RPM Ratio	350	250	175	146	117	87.5	70.0	58.3	43.8	35.0	29.2	21.9	17.5	Frame Size
Input HP	0.268	0.268	0.268	0.268	0.268	0.268	0.268	0.268	0.134	0.134	0.134	-	-	
Output Torque in-lbs	41.0	57.5	82.1	98.5	123	164	205	246	164	205	246	-	-	1120
Overhung Load lbs	132	143	165	176	187	209	220	231	254	276	287	-	-	
Input HP	0.536	0.536	0.536	0.536	0.536	0.536	0.536	0.536	0.268	0.268	0.268	-	-	
Output Torque in-lbs	82.1	115	164	197	246	328	410	492	328	410	492	-	-	1220
Overhung Load lbs	187	209	231	243	265	298	309	331	353	375	386	-	-	
Input HP	-	-	-	-	-	-	-	-	-	-	0.134	0.134	-	
Output Torque in-lbs	-	-	-	-	-	-	-	-	-	-	328	410	-	1230
Overhung Load lbs	-	-	-	-	-	-	-	-	-	-	397	397	-	
Input HP	1.07	1.07	1.07	1.07	1.07	1.07	1.07	1.07	0.536	0.536	-	-	-	
Output Torque in-lbs	164	230	328	394	492	656	820	984	656	820	984	-	-	1320
Overhung Load lbs	309	353	386	408	430	463	496	529	617	639	-	-	-	
Input HP	-	-	-	-	-	-	-	-	-	-	0.268	0.268	-	
Output Torque in-lbs	-	-	-	-	-	-	-	-	-	-	657	821	-	1330
Overhung Load lbs	-	-	-	-	-	-	-	-	-	-	661	683	-	

2 ...to your SELECTION HP...

3 ...to find your FRAME SIZE

If Overhung Load is present, it must be checked against the capacity of the selection.



For special circumstances affecting Frame Size selection such as:

- Overhung Load
- Shock Loading

Consult Appendix, pages 5.8.

Configure a Model Number

Output Shaft Orientation

Type	Prefix
Universal Direction (Maintenance Free)	N

Mounting Style

Type	Prefix
Shaft Mount (Hollow Shaft)	Y
Flange (Solid Shaft)	F
Foot (Solid Shaft)	H

Input Connection

Input Connection	Prefix
C-Face Adapter with jaw coupling	J
Quill C-Face	X

Modification

	Prefix
Special	S
Standard	

Frame Size

1120	1520
1220	1530
1230	1531
1320	1540
1330	1630
1340	1631
1420	1632
1430	1640
1440	

Output Shaft Direction (solid shaft only)

Direction (when viewed from motor end)	Suffix
Projects to Left Side	L
Projects to Right Side	R
Projects to Both Sides	T

*For dimensions refer to page 4.2 to 4.5

Required to be added at end of model number when ordering:

- NEMA frame size for C-face adapter with jaw coupling or Quill adapter.
- Bore size must be supplied for output hollow bore units.
- Optional conduit box positions must be specified, otherwise Y1 is supplied.
- Optional Industry Package SSC code, refer to page 4.11.

Speed Reducers

Nomenclature

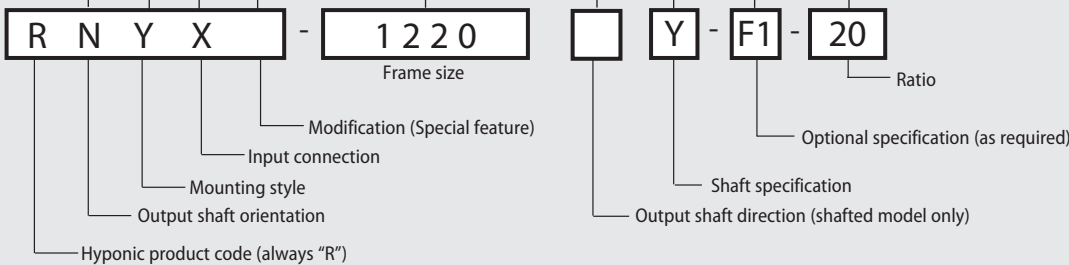

Nomenclature

Shaft Specifications

Input Shaft	Output Shaft		Suffix
	Hollow	Solid	
Metric (JIS)	Key (Inch)	Key (Inch)	
Metric (DIN)	-	Key (mm)	E
Inch	Key (Inch)	Key (Inch)	Y

Optional Specifications (as required)

Specification	Code
Hollow Bore Options	
Flange (Extended or Metric) page 4.5 (for motor clearance)	
Left (viewed from motor end)	F1
Right (viewed from motor end)	G1
Solid Shaft Options pages 4.2-4.3	
Plug-in Shaft	X1
Plug-in Shaft with Bolt-on Feet page 4.4	
Bottom	J1
Opposite from Motor	S1
Top	M1
Plug-in Shaft with Flange (Extended or Metric) page 4.5 (for motor clearance)	
Left (viewed from motor end)	P1
Right (viewed from motor end)	Q1

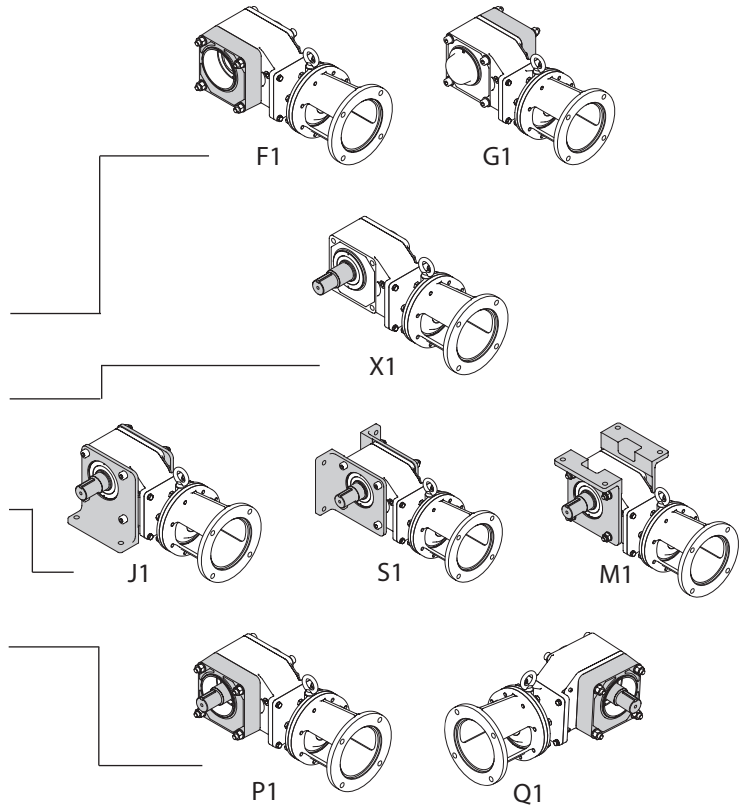

Speed Reducers

Nomenclature

Nominal Total Ratio

5	20	60	200	600
7	25	80	240	720
10	30	100	300	900
12	40	120	360	1200
15	50	150	480	1440

Nomenclature Example:

RNYX – 1220Y –F1 – 20

R – Hyponic®

N – Universal Mount

Y – Shaft Mount (Hollow Shaft)

X – Quill C-Face Input

1220 – Frame Size

Y – Inch Shaft Specification

F1 – Extended flange on Left side
(viewed from motor end)

20 – Ratio

AGMA Load Classifications

AGMA Tables
Speed Reducers

TYPE OF APPLICATION	TYPE OF LOAD
Agitators	
Pure liquids	U
Liquids and solids	M
Variable-density liquids	M
Blowers	
Centrifugal	U
Lobe	M
Vane	U
Brewing and Distilling	
Bottling machinery	U
Brew kettles, cont. duty	U
Cookers, cont. duty	U
Mash tubs, cont. duty	U
Scale hopper, frequent starts	M
Can Filling Machines	U
Cane Knives	M
Car Dumpers	H
Car Pullers	M
Clarifiers	U
Classifiers	M
Clay Working Machinery	
Brick press	H
Briquette machine	H
Clay working machinery	M
Pug mill	M
Compressors	
Centrifugal	U
Lobe	M
Reciprocating, multi-cylinder	M
Reciprocating, single-cylinder	H
Conveyors — Uniformly Loaded or Fed	
Apron	U
Assembly	U
Belt	U
Bucket	U
Chain	U
Flight	U
Oven	U
Screw	U
Conveyors — Heavy Duty, Not Uniformly Fed	
Apron	M
Assembly	M
Belt	M
Bucket	M
Chain	M
Flight	M
Live roll oven	M
Reciprocating	H
Screw	M
Shaker	H
Cranes (Except for Dry Dock Cranes)	
Main hoists	U
Bridge travel	S
Trolley travel	S
Crusher	
Ore H	
Stone	H
Sugar	M
Dredges	
Cable reels	M
Conveyors	M
Cutter head drives	H
Jig drives	H
Maneuvering winches	M
Pumps	M
Screen drive	H
Stackers	M
Utility winches	M
Dry Dock Cranes	S
Elevators	
Bucket, uniform load	U
Bucket, heavy load	M
Bucket, cont.	U
Centrifugal discharge	U
Escalators	U
Freight	M
Gravity discharge	U
Man lifts	S
Passenger	S
Extruders (Plastics)	
Blow molders	M
Coating	U
Film	U
Pipe	U
Pre-plasticizers	M
Rods	U
Sheet	U
Tubing	U
Fans	
Centrifugal	U
Cooling towers	S
Forced draft	S
Induced draft	M
Large (mine, etc.)	M

TYPE OF APPLICATION	TYPE OF LOAD
Large (industrial)	M
Light (small diameter)	U
Feeders	
Apron	M
Belt	M
Disc	U
Reciprocating	H
Screw	M
Food Industry	
Beet slicer	M
Cereal cooker	U
Dough mixer	M
Meat grinders	M
Generators (Not Welding)	U
Hammer Mills	H
Hoists	
Heavy duty	H
Medium duty	M
Skip	M
Laundry Washers — Reversing	M
Laundry Tumblers	M
Line Shaft	
Drive processing equipment	M
Light	U
Other line shafts	U
Lumber Industry	
Barkers — hydraulic and mechanical	S
Burner conveyor	M
Chain Saw and Drag Saw	H
Chain transfer	H
Crane way transfer	H
De-barking drum	S
Edger feed	H
Gang feed	M
Geen chain	M
Live rolls	H
Log haul-lockline	H
Log turning device	H
Main log conveyor	H
Off bearing rolls	M
Planer feed chains	M
Planer floor chains	M
Planer tilting hoist	M
Re-saw merry-go-round conveyor	M
Roll cases	H
Slab conveyor	H
Small waste-conveyor-belt	U
Small waste-conveyor-chain	M
Sorting table	M
Tipple hoist conveyor	M
Tipple hoist drive	M
Transfer conveyors	M
Transfer rolls	M
Tray drive	M
Trimmer feed	M
Waste conveyor	M
Machine Tools	
Bending roll	M
Notching press, belt driven	S
Plate planer	H
Punch press, gear driven	H
Tapping machine	H
Other machine tools	
Main drives	M
Auxiliary drives	U
Metal Mills	
Draw bench carriage and main drive	M
Forming machines	H
Pinch, dryer and scrubber rolls, reversing	S
Slitters	S
Table conveyors, nonreversing	
Group drives	M
Individual drives	H
Table conveyors, reversing	S
Wire drawing and flattening machine	M
Wire winding machine	M
Mills, Rotary Type	
Ball M	
Cement kilns	M
Dryers and coolers	M
Kilns	M
Pebble	M
Rod, plain and wedge bar	M
Tumbling barrels	H
Mixers	
Concrete mixers, cont.	M
Concrete mixers, intermittent	M
Constant density	U
Variable density	M
Oil Industry	
Chillers	M
Oil well pumps	S
Paraffin filter press	M
Rotary kilns	M

TYPE OF APPLICATION	TYPE OF LOAD
Paper Mills	
Agitators (mixers)	M
Barker, hydraulic	S
Barker, mechanical	S
Barking drum	S
Beater and pulper	M
Bleacher	U
Calenders	M
Calenders, super	H
Converting machine (except cutters, platers)	M
Conveyors	U
Couch	M
Cutters, platers	H
Cylinders	M
Dryers	M
Felt stretcher	M
Felt whipper	H
Jordans	H
Log haul	H
Presses	U
Pulp machine reel	M
Stock chest	M
Suction roll	U
Washers and thickeners	M
Winders	U
Printing Presses	S
Pullers, Barge Haul	H
Pumps	
Centrifugal	U
Proportioning	M
Reciprocating	
Single acting, 3 or more cylinders	M
Double acting, 2 or more cylinders	M
Rotary-gear type	U
Rubber and Plastics Industries	
Crackers	H
Laboratory equipment	M
Mixing mills	H
Refiners	M
Rubber calenders	M
Rubber mill (2 on line)	M
Rubber mill (3 on line)	U
Sheeter	M
Tire building machines	S
Tire and tube press openers	S
Tubers and strainers	M
Warming mills	M
Sand Muller	M
Screens	
Air washing	U
Rotary, stone or gravel	M
Traveling water intake	U
Sewage Disposal Equipment	
Bar screens	U
Chemical fenders	U
Collectors, circuline or straightline	U
Dewatering screens	M
Grit collectors	U
Scum breakers	M
Slow or rapid mixers	M
Sludge collectors	U
Thickeners	M
Vacuum filters	M
Slab Pushers	M
Steering Gear	S
Stokers	U
Sugar Industry	
Cane knives	M
Crushers	M
Mills	H
Textile Industry	
Batchers	M
Calenders	M
Cards	M
Dry cans	M
Dryers	M
Dyeing machinery	M
Knitting machines	S
Looms	M
Mangles	M
Nappers	M
Pads	M
Range drives	S
Slashers	M
Soapers	M
Spinners	M
Tenter frames	M
Washers	M
Winders	M
Windlass	S

U = Uniform Load	H = Heavy Shock
M = Moderate Shock	S = Contact Sumitomo

This page intentionally left blank.

Speed
Reducers

Selection
Tables

Quill Frame Size Selection Tables

Dimensions: Frame Size	Page	Frame Size	Page
1100	2.20	1400	2.23
1200	2.21	1500	2.24
1300	2.22	1600	2.25

Output RPM 14.6 thru 1.22 continued on next page.

Output RPM	350	250	175	146	117	87.5	70.0	58.3	43.8	35.0	29.2	21.9	17.5	Frame Size
Ratio	5	7	10	12	15	20	25	30	40	50	60	80	100	
Input Power HP <i>(kW)</i>	0.268 <i>(0.200)</i>	0.268 <i>(0.200)</i>	0.268 <i>(0.200)</i>	0.268 <i>(0.200)</i>	0.268 <i>(0.200)</i>	0.268 <i>(0.200)</i>	0.268 <i>(0.200)</i>	0.268 <i>(0.200)</i>	0.134 <i>(0.100)</i>	0.134 <i>(0.100)</i>	0.134 <i>(0.100)</i>	-	-	1120
Output Torque in-lbs <i>(N-m)</i>	41.1 <i>(4.64)</i>	57.5 <i>(6.49)</i>	82.1 <i>(9.28)</i>	98.5 <i>(11.1)</i>	123 <i>(13.9)</i>	164 <i>(18.6)</i>	205 <i>(23.2)</i>	246 <i>(27.8)</i>	164 <i>(18.6)</i>	205 <i>(23.2)</i>	246 <i>(27.8)</i>	-	-	
Solid Shaft OHL lbs <i>(N)</i>	132 <i>(588)</i>	143 <i>(637)</i>	165 <i>(735)</i>	176 <i>(785)</i>	187 <i>(834)</i>	209 <i>(932)</i>	220 <i>(980)</i>	232 <i>(1030)</i>	254 <i>(1130)</i>	277 <i>(1230)</i>	286 <i>(1270)</i>	-	-	
Input Power HP <i>(kW)</i>	0.536 <i>(0.400)</i>	0.536 <i>(0.400)</i>	0.536 <i>(0.400)</i>	0.536 <i>(0.400)</i>	0.536 <i>(0.400)</i>	0.536 <i>(0.400)</i>	0.536 <i>(0.400)</i>	0.536 <i>(0.400)</i>	0.268 <i>(0.200)</i>	0.268 <i>(0.200)</i>	0.268 <i>(0.200)</i>	-	-	1220
Output Torque in-lbs <i>(N-m)</i>	82.1 <i>(9.28)</i>	115 <i>(13.0)</i>	164 <i>(18.6)</i>	197 <i>(22.3)</i>	246 <i>(27.8)</i>	328 <i>(37.1)</i>	411 <i>(46.4)</i>	493 <i>(55.7)</i>	328 <i>(37.1)</i>	411 <i>(46.4)</i>	493 <i>(55.7)</i>	-	-	
Solid Shaft OHL lbs <i>(N)</i>	187 <i>(834)</i>	209 <i>(932)</i>	232 <i>(1030)</i>	243 <i>(1080)</i>	265 <i>(1180)</i>	297 <i>(1320)</i>	308 <i>(1370)</i>	330 <i>(1470)</i>	353 <i>(1570)</i>	375 <i>(1670)</i>	387 <i>(1720)</i>	-	-	
Input Power HP <i>(kW)</i>	-	-	-	-	-	-	-	-	-	-	-	0.134 <i>(0.100)</i>	0.134 <i>(0.100)</i>	1230
Output Torque in-lbs <i>(N-m)</i>	-	-	-	-	-	-	-	-	-	-	-	328 <i>(37.1)</i>	411 <i>(46.4)</i>	
Solid Shaft OHL lbs <i>(N)</i>	-	-	-	-	-	-	-	-	-	-	-	398 <i>(1770)</i>	398 <i>(1770)</i>	
Input Power HP <i>(kW)</i>	1.07 <i>(0.800)</i>	1.07 <i>(0.800)</i>	1.07 <i>(0.800)</i>	1.07 <i>(0.800)</i>	1.07 <i>(0.800)</i>	1.07 <i>(0.800)</i>	1.07 <i>(0.800)</i>	1.07 <i>(0.800)</i>	0.536 <i>(0.400)</i>	0.536 <i>(0.400)</i>	0.536 <i>(0.400)</i>	-	-	1320
Output Torque in-lbs <i>(N-m)</i>	164 <i>(18.6)</i>	230 <i>(26.0)</i>	328 <i>(37.1)</i>	394 <i>(44.5)</i>	493 <i>(55.7)</i>	657 <i>(74.2)</i>	821 <i>(92.8)</i>	985 <i>(111)</i>	657 <i>(74.2)</i>	821 <i>(92.8)</i>	985 <i>(111)</i>	-	-	
Solid Shaft OHL lbs <i>(N)</i>	308 <i>(1370)</i>	353 <i>(1570)</i>	387 <i>(1720)</i>	407 <i>(1810)</i>	441 <i>(1960)</i>	486 <i>(2160)</i>	508 <i>(2260)</i>	528 <i>(2350)</i>	573 <i>(2550)</i>	618 <i>(2750)</i>	638 <i>(2840)</i>	-	-	
Input Power HP <i>(kW)</i>	-	-	-	-	-	-	-	-	-	-	-	0.268 <i>(0.200)</i>	0.268 <i>(0.200)</i>	1330
Output Torque in-lbs <i>(N-m)</i>	-	-	-	-	-	-	-	-	-	-	-	657 <i>(74.2)</i>	821 <i>(92.8)</i>	
Solid Shaft OHL lbs <i>(N)</i>	-	-	-	-	-	-	-	-	-	-	-	661 <i>(2940)</i>	683 <i>(3040)</i>	
Input Power HP <i>(kW)</i>	-	-	-	-	-	-	-	-	-	-	-	-	-	1340
Output Torque in-lbs <i>(N-m)</i>	-	-	-	-	-	-	-	-	-	-	-	-	-	
Solid Shaft OHL lbs <i>(N)</i>	-	-	-	-	-	-	-	-	-	-	-	-	-	
Input Power HP <i>(kW)</i>	2.06 <i>(1.54)</i>	2.06 <i>(1.54)</i>	2.06 <i>(1.54)</i>	2.06 <i>(1.54)</i>	2.06 <i>(1.54)</i>	2.06 <i>(1.54)</i>	2.06 <i>(1.54)</i>	2.06 <i>(1.54)</i>	1.07 <i>(0.800)</i>	1.07 <i>(0.800)</i>	1.07 <i>(0.800)</i>	-	-	1420
Output Torque in-lbs <i>(N-m)</i>	316 <i>(35.7)</i>	443 <i>(50.0)</i>	632 <i>(71.4)</i>	759 <i>(85.7)</i>	948 <i>(107)</i>	1260 <i>(143)</i>	1580 <i>(179)</i>	1900 <i>(214)</i>	1310 <i>(148)</i>	1640 <i>(186)</i>	1970 <i>(223)</i>	-	-	
Solid Shaft OHL lbs <i>(N)</i>	463 <i>(2060)</i>	517 <i>(2300)</i>	585 <i>(2600)</i>	618 <i>(2750)</i>	661 <i>(2940)</i>	717 <i>(3190)</i>	760 <i>(3380)</i>	805 <i>(3580)</i>	859 <i>(3820)</i>	904 <i>(4020)</i>	937 <i>(4170)</i>	-	-	

Speed Reducers Selection Tables

Quill Frame Size Selection Tables

Dimensions:	Frame Size	Page	Frame Size	Page
	1100	2.20	1400	2.23
	1200	2.21	1500	2.24
	1300	2.22	1600	2.25

Output RPM	14.6	11.7	8.75	7.29	5.83	4.86	3.65	2.92	2.43	1.94	1.46	1.22	Frame Size
Ratio	120	150	200	240	300	360	480	600	720	900	1200	1440	
Input Power HP	-	-	-	-	-	-	-	-	-	-	-	-	1120
(kW)	-	-	-	-	-	-	-	-	-	-	-	-	
Output Torque in-lbs <i>(N-m)</i>	-	-	-	-	-	-	-	-	-	-	-	-	
Solid Shaft OHL lbs <i>(N)</i>	-	-	-	-	-	-	-	-	-	-	-	-	
Input Power HP	-	-	-	-	-	-	-	-	-	-	-	-	1220
(kW)	-	-	-	-	-	-	-	-	-	-	-	-	
Output Torque in-lbs <i>(N-m)</i>	-	-	-	-	-	-	-	-	-	-	-	-	
Solid Shaft OHL lbs <i>(N)</i>	-	-	-	-	-	-	-	-	-	-	-	-	
Input Power HP	0.134	-	-	-	-	-	-	-	-	-	-	-	1230
(kW)	(0.100)	-	-	-	-	-	-	-	-	-	-	-	
Output Torque in-lbs <i>(N-m)</i>	493 <i>(55.7)</i>	-	-	-	-	-	-	-	-	-	-	-	
Solid Shaft OHL lbs <i>(N)</i>	407 <i>(1810)</i>	-	-	-	-	-	-	-	-	-	-	-	
Input Power HP	-	-	-	-	-	-	-	-	-	-	-	-	1320
(kW)	-	-	-	-	-	-	-	-	-	-	-	-	
Output Torque in-lbs <i>(N-m)</i>	-	-	-	-	-	-	-	-	-	-	-	-	
Solid Shaft OHL lbs <i>(N)</i>	-	-	-	-	-	-	-	-	-	-	-	-	
Input Power HP	0.268	0.125	0.125	0.125	-	-	-	-	-	-	-	-	1330
(kW)	(0.200)	(0.0933)	(0.0933)	(0.0933)	-	-	-	-	-	-	-	-	
Output Torque in-lbs <i>(N-m)</i>	985 <i>(111)</i>	574 <i>(64.9)</i>	766 <i>(86.5)</i>	919 <i>(104)</i>	-	-	-	-	-	-	-	-	
Solid Shaft OHL lbs <i>(N)</i>	695 <i>(3090)</i>	695 <i>(3090)</i>	695 <i>(3090)</i>	695 <i>(3090)</i>	-	-	-	-	-	-	-	-	
Input Power HP	-	-	-	-	0.134	0.134	0.125	0.0999	0.0833	-	-	-	1340
(kW)	-	-	-	-	(0.100)	(0.100)	(0.0932)	(0.0745)	(0.0621)	-	-	-	
Output Torque in-lbs <i>(N-m)</i>	-	-	-	-	1160 <i>(131)</i>	1390 <i>(157)</i>	1730 <i>(195)</i>	1730 <i>(195)</i>	1730 <i>(195)</i>	-	-	-	
Solid Shaft OHL lbs <i>(N)</i>	-	-	-	-	695 <i>(3090)</i>	695 <i>(3090)</i>	695 <i>(3090)</i>	695 <i>(3090)</i>	695 <i>(3090)</i>	-	-	-	
Input Power HP	-	-	-	-	-	-	-	-	-	-	-	-	1420
(kW)	-	-	-	-	-	-	-	-	-	-	-	-	
Output Torque in-lbs <i>(N-m)</i>	-	-	-	-	-	-	-	-	-	-	-	-	
Solid Shaft OHL lbs <i>(N)</i>	-	-	-	-	-	-	-	-	-	-	-	-	

Speed Reducers

Selection Tables

Quill Frame Size Selection Tables

Dimensions: Frame Size	Page	Frame Size	Page
1100	2.20	1400	2.23
1200	2.21	1500	2.24
1300	2.22	1600	2.25

Output RPM 14.6 thru 1.22 continued on next page.

Output RPM	350	250	175	146	117	87.5	70.0	58.3	43.8	35.0	29.2	21.9	17.5	Frame Size
Ratio	5	7	10	12	15	20	25	30	40	50	60	80	100	
Input Power HP	-	-	-	-	-	-	-	-	-	-	-	0.536	0.536	1430
(kW)	-	-	-	-	-	-	-	-	-	-	-	(0.400)	(0.400)	
Output Torque in-lbs <i>(N-m)</i>	-	-	-	-	-	-	-	-	-	-	-	1310 <i>(148)</i>	1640 <i>(186)</i>	
Solid Shaft OHL lbs <i>(N)</i>	-	-	-	-	-	-	-	-	-	-	-	960 <i>(4270)</i>	980 <i>(4360)</i>	
Input Power HP	-	-	-	-	-	-	-	-	-	-	-	-	-	1440
(kW)	-	-	-	-	-	-	-	-	-	-	-	-	-	
Output Torque in-lbs <i>(N-m)</i>	-	-	-	-	-	-	-	-	-	-	-	-	-	
Solid Shaft OHL lbs <i>(N)</i>	-	-	-	-	-	-	-	-	-	-	-	-	-	
Input Power HP	-	-	-	-	-	-	-	-	-	-	-	-	-	1520
(kW)	-	-	-	-	-	-	-	-	-	-	-	-	-	
Output Torque in-lbs <i>(N-m)</i>	-	-	-	-	-	-	-	-	-	-	-	-	-	
Solid Shaft OHL lbs <i>(N)</i>	-	-	-	-	-	-	-	-	-	-	-	-	-	
Input Power HP	-	-	-	-	-	-	-	-	-	-	-	-	-	1521
(kW)	-	-	-	-	-	-	-	-	-	-	-	-	-	
Output Torque in-lbs <i>(N-m)</i>	-	-	-	-	-	-	-	-	-	-	-	-	-	
Solid Shaft OHL lbs <i>(N)</i>	-	-	-	-	-	-	-	-	-	-	-	-	-	
Input Power HP	-	-	-	-	-	-	-	-	-	-	-	-	-	1522
(kW)	-	-	-	-	-	-	-	-	-	-	-	-	-	
Output Torque in-lbs <i>(N-m)</i>	-	-	-	-	-	-	-	-	-	-	-	-	-	
Solid Shaft OHL lbs <i>(N)</i>	-	-	-	-	-	-	-	-	-	-	-	-	-	
Input Power HP	-	-	-	-	-	-	-	-	-	-	-	1.07	1.07	1530
(kW)	-	-	-	-	-	-	-	-	-	-	-	(0.800)	(0.800)	
Output Torque in-lbs <i>(N-m)</i>	-	-	-	-	-	-	-	-	-	-	-	2630 <i>(297)</i>	3280 <i>(371)</i>	
Solid Shaft OHL lbs <i>(N)</i>	-	-	-	-	-	-	-	-	-	-	-	1380 <i>(6130)</i>	1400 <i>(6230)</i>	
Input Power HP	-	-	-	-	-	-	-	-	2.06	2.06	2.06	2.06	-	1531
(kW)	-	-	-	-	-	-	-	-	(1.54)	(1.54)	(1.54)	(1.54)	-	
Output Torque in-lbs <i>(N-m)</i>	-	-	-	-	-	-	-	-	2530 <i>(286)</i>	3160 <i>(357)</i>	3790 <i>(429)</i>	5060 <i>(571)</i>	-	
Solid Shaft OHL lbs <i>(N)</i>	-	-	-	-	-	-	-	-	1250 <i>(5540)</i>	1310 <i>(5830)</i>	1360 <i>(6030)</i>	1380 <i>(6130)</i>	-	

Speed Reducers Selection Tables

Quill Frame Size Selection Tables

Dimensions:	Frame Size	Page	Frame Size	Page
	1100	2.20	1400	2.23
	1200	2.21	1500	2.24
	1300	2.22	1600	2.25

Output RPM	14.6	11.7	8.75	7.29	5.83	4.86	3.65	2.92	2.43	1.94	1.46	1.22	Frame Size
Ratio	120	150	200	240	300	360	480	600	720	900	1200	1440	
Input Power HP	0.536	0.250	0.250	0.250	-	-	-	-	-	-	-	-	1430
<i>(kW)</i>	<i>(0.400)</i>	<i>(0.187)</i>	<i>(0.187)</i>	<i>(0.187)</i>	-	-	-	-	-	-	-	-	
Output Torque in-lbs	1970	1150	1530	1840	-	-	-	-	-	-	-	-	
<i>(N-m)</i>	<i>(223)</i>	<i>(130)</i>	<i>(173)</i>	<i>(208)</i>	-	-	-	-	-	-	-	-	
Solid Shaft OHL lbs	980	980	980	980	-	-	-	-	-	-	-	-	
<i>(N)</i>	<i>(4360)</i>	<i>(4360)</i>	<i>(4360)</i>	<i>(4360)</i>	-	-	-	-	-	-	-	-	
Input Power HP	-	-	-	-	0.268	0.268	0.250	0.200	0.167	0.133	0.0999	0.0833	1440
<i>(kW)</i>	-	-	-	-	<i>(0.200)</i>	<i>(0.200)</i>	<i>(0.186)</i>	<i>(0.149)</i>	<i>(0.124)</i>	<i>(0.0994)</i>	<i>(0.0745)</i>	<i>(0.0621)</i>	
Output Torque in-lbs	-	-	-	-	2320	2780	3460	3460	3460	3460	3460	3460	
<i>(N-m)</i>	-	-	-	-	<i>(262)</i>	<i>(314)</i>	<i>(390)</i>	<i>(390)</i>	<i>(390)</i>	<i>(390)</i>	<i>(390)</i>	<i>(390)</i>	
Solid Shaft OHL lbs	-	-	-	-	980	980	980	980	980	980	980	980	
<i>(N)</i>	-	-	-	-	<i>(4360)</i>	<i>(4360)</i>	<i>(4360)</i>	<i>(4360)</i>	<i>(4360)</i>	<i>(4360)</i>	<i>(4360)</i>	<i>(4360)</i>	
Input Power HP	-	-	-	-	-	-	-	-	-	-	-	-	1520
<i>(kW)</i>	-	-	-	-	-	-	-	-	-	-	-	-	
Output Torque in-lbs	-	-	-	-	-	-	-	-	-	-	-	-	
<i>(N-m)</i>	-	-	-	-	-	-	-	-	-	-	-	-	
Solid Shaft OHL lbs	-	-	-	-	-	-	-	-	-	-	-	-	
<i>(N)</i>	-	-	-	-	-	-	-	-	-	-	-	-	
Input Power HP	-	-	-	-	-	-	-	-	-	-	-	-	1521
<i>(kW)</i>	-	-	-	-	-	-	-	-	-	-	-	-	
Output Torque in-lbs	-	-	-	-	-	-	-	-	-	-	-	-	
<i>(N-m)</i>	-	-	-	-	-	-	-	-	-	-	-	-	
Solid Shaft OHL lbs	-	-	-	-	-	-	-	-	-	-	-	-	
<i>(N)</i>	-	-	-	-	-	-	-	-	-	-	-	-	
Input Power HP	-	-	-	-	-	-	-	-	-	-	-	-	1522
<i>(kW)</i>	-	-	-	-	-	-	-	-	-	-	-	-	
Output Torque in-lbs	-	-	-	-	-	-	-	-	-	-	-	-	
<i>(N-m)</i>	-	-	-	-	-	-	-	-	-	-	-	-	
Solid Shaft OHL lbs	-	-	-	-	-	-	-	-	-	-	-	-	
<i>(N)</i>	-	-	-	-	-	-	-	-	-	-	-	-	
Input Power HP	1.07	0.500	0.500	0.500	-	-	-	-	-	-	-	-	1530
<i>(kW)</i>	<i>(0.800)</i>	<i>(0.373)</i>	<i>(0.373)</i>	<i>(0.373)</i>	-	-	-	-	-	-	-	-	
Output Torque in-lbs	3940	2300	3060	3680	-	-	-	-	-	-	-	-	
<i>(N-m)</i>	<i>(445)</i>	<i>(260)</i>	<i>(346)</i>	<i>(415)</i>	-	-	-	-	-	-	-	-	
Solid Shaft OHL lbs	1400	1400	1400	1400	-	-	-	-	-	-	-	-	
<i>(N)</i>	<i>(6230)</i>	<i>(6230)</i>	<i>(6230)</i>	<i>(6230)</i>	-	-	-	-	-	-	-	-	
Input Power HP	-	-	-	-	-	-	-	-	-	-	-	-	1531
<i>(kW)</i>	-	-	-	-	-	-	-	-	-	-	-	-	
Output Torque in-lbs	-	-	-	-	-	-	-	-	-	-	-	-	
<i>(N-m)</i>	-	-	-	-	-	-	-	-	-	-	-	-	
Solid Shaft OHL lbs	-	-	-	-	-	-	-	-	-	-	-	-	
<i>(N)</i>	-	-	-	-	-	-	-	-	-	-	-	-	

Speed Reducers

Selection Tables

Quill Frame Size Selection Tables

Dimensions: Frame Size	Page	Frame Size	Page
1100	2.20	1400	2.23
1200	2.21	1500	2.24
1300	2.22	1600	2.25

Output RPM 14.6 thru 1.22 continued on next page.

Output RPM	350	250	175	146	117	87.5	70.0	58.3	43.8	35.0	29.2	21.9	17.5	Frame Size
Ratio	5	7	10	12	15	20	25	30	40	50	60	80	100	
Input Power HP	-	-	-	-	-	-	-	-	-	-	-	-	-	1540
(kW)	-	-	-	-	-	-	-	-	-	-	-	-	-	
Output Torque in-lbs <i>(N-m)</i>	-	-	-	-	-	-	-	-	-	-	-	-	-	
Solid Shaft OHL lbs <i>(N)</i>	-	-	-	-	-	-	-	-	-	-	-	-	-	
Input Power HP	-	-	3.00	3.00	3.00	3.00	3.00	3.00	3.00	3.00	3.00	3.00	3.00	1630
(kW)	-	-	(2.24)	(2.24)	(2.24)	(2.24)	(2.24)	(2.24)	(2.24)	(2.24)	(2.24)	(2.24)	(2.24)	
Output Torque in-lbs <i>(N-m)</i>	-	-	919 <i>(104)</i>	1100 <i>(125)</i>	1380 <i>(156)</i>	1840 <i>(208)</i>	2300 <i>(260)</i>	2760 <i>(311)</i>	3680 <i>(415)</i>	4590 <i>(519)</i>	5510 <i>(623)</i>	7350 <i>(830)</i>	9200 <i>(1039)</i>	
Solid Shaft OHL lbs <i>(N)</i>	-	-	1330 <i>(5930)</i>	1420 <i>(6330)</i>	1500 <i>(6670)</i>	1650 <i>(7350)</i>	1740 <i>(7750)</i>	1820 <i>(8090)</i>	1910 <i>(8480)</i>	2000 <i>(8880)</i>	2060 <i>(9170)</i>	2170 <i>(9660)</i>	2210 <i>(9810)</i>	
Input Power HP	-	-	-	-	-	-	-	-	-	-	-	-	-	1631
(kW)	-	-	-	-	-	-	-	-	-	-	-	-	-	
Output Torque in-lbs <i>(N-m)</i>	-	-	-	-	-	-	-	-	-	-	-	-	-	
Solid Shaft OHL lbs <i>(N)</i>	-	-	-	-	-	-	-	-	-	-	-	-	-	
Input Power HP	-	-	5.00	5.00	5.00	5.00	5.00	5.00	5.00	5.00	5.00	-	-	1632
(kW)	-	-	(3.73)	(3.73)	(3.73)	(3.73)	(3.73)	(3.73)	(3.73)	(3.73)	(3.73)	-	-	
Output Torque in-lbs <i>(N-m)</i>	-	-	1530 <i>(173)</i>	1840 <i>(208)</i>	2300 <i>(260)</i>	3060 <i>(346)</i>	3830 <i>(433)</i>	4590 <i>(519)</i>	6130 <i>(692)</i>	7660 <i>(865)</i>	9190 <i>(1038)</i>	-	-	
Solid Shaft OHL lbs <i>(N)</i>	-	-	1330 <i>(5930)</i>	1420 <i>(6330)</i>	1500 <i>(6670)</i>	1650 <i>(7350)</i>	1740 <i>(7750)</i>	1820 <i>(8090)</i>	1910 <i>(8480)</i>	2000 <i>(8880)</i>	2060 <i>(9170)</i>	-	-	
Input Power HP	-	-	-	-	-	-	-	-	-	-	-	-	-	1633
(kW)	-	-	-	-	-	-	-	-	-	-	-	-	-	
Output Torque in-lbs <i>(N-m)</i>	-	-	-	-	-	-	-	-	-	-	-	-	-	
Solid Shaft OHL lbs <i>(N)</i>	-	-	-	-	-	-	-	-	-	-	-	-	-	
Input Power HP	-	-	-	-	-	-	-	-	-	-	-	-	-	1634
(kW)	-	-	-	-	-	-	-	-	-	-	-	-	-	
Output Torque in-lbs <i>(N-m)</i>	-	-	-	-	-	-	-	-	-	-	-	-	-	
Solid Shaft OHL lbs <i>(N)</i>	-	-	-	-	-	-	-	-	-	-	-	-	-	
Input Power HP	-	-	-	-	-	-	-	-	-	-	-	-	-	1640
(kW)	-	-	-	-	-	-	-	-	-	-	-	-	-	
Output Torque in-lbs <i>(N-m)</i>	-	-	-	-	-	-	-	-	-	-	-	-	-	
Solid Shaft OHL lbs <i>(N)</i>	-	-	-	-	-	-	-	-	-	-	-	-	-	

Speed Reducers Selection Tables

Quill Frame Size Selection Tables

Dimensions:	Frame Size	Page	Frame Size	Page
	1100	2.20	1400	2.23
	1200	2.21	1500	2.24
	1300	2.22	1600	2.25

Output RPM	14.6	11.7	8.75	7.29	5.83	4.86	3.65	2.92	2.43	1.94	1.46	1.22	Frame Size
Ratio	120	150	200	240	300	360	480	600	720	900	1200	1440	
Input Power HP	-	-	-	-	0.536	0.536	0.468	0.375	0.312	0.250	0.187	0.156	1540
(kW)	-	-	-	-	(0.400)	(0.400)	(0.349)	(0.279)	(0.233)	(0.186)	(0.140)	(0.116)	
Output Torque in-lbs	-	-	-	-	4640	5560	6480	6480	6480	6480	6480	6480	
(N-m)	-	-	-	-	(524)	(629)	(732)	(732)	(732)	(732)	(732)	(732)	
Solid Shaft OHL lbs	-	-	-	-	1400	1400	1400	1400	1400	1400	1400	1400	
(N)	-	-	-	-	(6230)	(6230)	(6230)	(6230)	(6230)	(6230)	(6230)	(6230)	
Input Power HP	3.00	-	-	-	-	-	-	-	-	-	-	-	1630
(kW)	(2.24)	-	-	-	-	-	-	-	-	-	-	-	
Output Torque in-lbs	11000	-	-	-	-	-	-	-	-	-	-	-	
(N-m)	(1246)	-	-	-	-	-	-	-	-	-	-	-	
Solid Shaft OHL lbs	2210	-	-	-	-	-	-	-	-	-	-	-	
(N)	(9810)	-	-	-	-	-	-	-	-	-	-	-	
Input Power HP	-	2.85	2.14	1.78	-	-	-	-	-	-	-	-	1631
(kW)	-	(2.13)	(1.60)	(1.33)	-	-	-	-	-	-	-	-	
Output Torque in-lbs	-	13100	13100	13100	-	-	-	-	-	-	-	-	
(N-m)	-	(1481)	(1481)	(1481)	-	-	-	-	-	-	-	-	
Solid Shaft OHL lbs	-	2210	2210	2210	-	-	-	-	-	-	-	-	
(N)	-	(9810)	(9810)	(9810)	-	-	-	-	-	-	-	-	
Input Power HP	-	-	-	-	-	-	-	-	-	-	-	-	1632
(kW)	-	-	-	-	-	-	-	-	-	-	-	-	
Output Torque in-lbs	-	-	-	-	-	-	-	-	-	-	-	-	
(N-m)	-	-	-	-	-	-	-	-	-	-	-	-	
Solid Shaft OHL lbs	-	-	-	-	-	-	-	-	-	-	-	-	
(N)	-	-	-	-	-	-	-	-	-	-	-	-	
Input Power HP	-	-	-	-	-	-	-	-	-	-	-	-	1633
(kW)	-	-	-	-	-	-	-	-	-	-	-	-	
Output Torque in-lbs	-	-	-	-	-	-	-	-	-	-	-	-	
(N-m)	-	-	-	-	-	-	-	-	-	-	-	-	
Solid Shaft OHL lbs	-	-	-	-	-	-	-	-	-	-	-	-	
(N)	-	-	-	-	-	-	-	-	-	-	-	-	
Input Power HP	-	-	-	-	-	-	-	-	-	-	-	-	1634
(kW)	-	-	-	-	-	-	-	-	-	-	-	-	
Output Torque in-lbs	-	-	-	-	-	-	-	-	-	-	-	-	
(N-m)	-	-	-	-	-	-	-	-	-	-	-	-	
Solid Shaft OHL lbs	-	-	-	-	-	-	-	-	-	-	-	-	
(N)	-	-	-	-	-	-	-	-	-	-	-	-	
Input Power HP	-	-	-	-	1.07	1.07	0.948	0.758	0.632	0.505	0.379	0.316	1640
(kW)	-	-	-	-	(0.800)	(0.800)	(0.707)	(0.566)	(0.471)	(0.377)	(0.283)	(0.236)	
Output Torque in-lbs	-	-	-	-	9270	11100	13100	13100	13100	13100	13100	13100	
(N-m)	-	-	-	-	(1048)	(1257)	(1481)	(1481)	(1481)	(1481)	(1481)	(1481)	
Solid Shaft OHL lbs	-	-	-	-	2210	2210	2210	2210	2210	2210	2210	2210	
(N)	-	-	-	-	(9810)	(9810)	(9810)	(9810)	(9810)	(9810)	(9810)	(9810)	

Speed Reducers

Selection Tables

C-Face Frame Size Selection Tables

Dimensions: Frame Size	Page	Frame Size	Page
1100	2.26	1400	2.29
1200	2.27	1500	2.30
1300	2.28	1600	2.31

Output RPM 14.6 thru 1.22 continued on next page.

Output RPM	350	250	175	146	117	87.5	70.0	58.3	43.8	35.0	29.2	21.9	17.5	Frame Size
Ratio	5	7	10	12	15	20	25	30	40	50	60	80	100	
Input Power HP <i>(kW)</i>	0.268 <i>(0.200)</i>	0.268 <i>(0.200)</i>	0.268 <i>(0.200)</i>	0.268 <i>(0.200)</i>	0.268 <i>(0.200)</i>	0.268 <i>(0.200)</i>	0.268 <i>(0.200)</i>	0.268 <i>(0.200)</i>	0.134 <i>(0.100)</i>	0.134 <i>(0.100)</i>	0.134 <i>(0.100)</i>	-	-	1120
Output Torque in-lbs <i>(N-m)</i>	41.1 <i>(4.64)</i>	57.5 <i>(6.49)</i>	82.1 <i>(9.28)</i>	98.5 <i>(11.1)</i>	123 <i>(13.9)</i>	164 <i>(18.6)</i>	205 <i>(23.2)</i>	246 <i>(27.8)</i>	164 <i>(18.6)</i>	205 <i>(23.2)</i>	246 <i>(27.8)</i>	-	-	
Solid Shaft OHL lbs <i>(N)</i>	132 <i>(588)</i>	143 <i>(637)</i>	165 <i>(735)</i>	176 <i>(785)</i>	187 <i>(834)</i>	209 <i>(932)</i>	220 <i>(980)</i>	232 <i>(1030)</i>	254 <i>(1130)</i>	277 <i>(1230)</i>	286 <i>(1270)</i>	-	-	
Input Power HP <i>(kW)</i>	0.536 <i>(0.400)</i>	0.536 <i>(0.400)</i>	0.536 <i>(0.400)</i>	0.536 <i>(0.400)</i>	0.536 <i>(0.400)</i>	0.536 <i>(0.400)</i>	0.536 <i>(0.400)</i>	0.536 <i>(0.400)</i>	0.268 <i>(0.200)</i>	0.268 <i>(0.200)</i>	0.268 <i>(0.200)</i>	-	-	1220
Output Torque in-lbs <i>(N-m)</i>	82.1 <i>(9.28)</i>	115 <i>(13.0)</i>	164 <i>(18.6)</i>	197 <i>(22.3)</i>	246 <i>(27.8)</i>	328 <i>(37.1)</i>	411 <i>(46.4)</i>	493 <i>(55.7)</i>	328 <i>(37.1)</i>	411 <i>(46.4)</i>	493 <i>(55.7)</i>	-	-	
Solid Shaft OHL lbs <i>(N)</i>	187 <i>(834)</i>	209 <i>(932)</i>	232 <i>(1030)</i>	243 <i>(1080)</i>	265 <i>(1180)</i>	297 <i>(1320)</i>	308 <i>(1370)</i>	330 <i>(1470)</i>	353 <i>(1570)</i>	375 <i>(1670)</i>	387 <i>(1720)</i>	-	-	
Input Power HP <i>(kW)</i>	-	-	-	-	-	-	-	-	-	-	-	0.134 <i>(0.100)</i>	0.134 <i>(0.100)</i>	1230
Output Torque in-lbs <i>(N-m)</i>	-	-	-	-	-	-	-	-	-	-	-	328 <i>(37.1)</i>	411 <i>(46.4)</i>	
Solid Shaft OHL lbs <i>(N)</i>	-	-	-	-	-	-	-	-	-	-	-	398 <i>(1770)</i>	398 <i>(1770)</i>	
Input Power HP <i>(kW)</i>	1.07 <i>(0.800)</i>	1.07 <i>(0.800)</i>	1.07 <i>(0.800)</i>	1.07 <i>(0.800)</i>	1.07 <i>(0.800)</i>	1.07 <i>(0.800)</i>	1.07 <i>(0.800)</i>	1.07 <i>(0.800)</i>	0.536 <i>(0.400)</i>	0.536 <i>(0.400)</i>	0.536 <i>(0.400)</i>	-	-	1320
Output Torque in-lbs <i>(N-m)</i>	164 <i>(18.6)</i>	230 <i>(26.0)</i>	328 <i>(37.1)</i>	394 <i>(44.5)</i>	493 <i>(55.7)</i>	657 <i>(74.2)</i>	821 <i>(92.8)</i>	985 <i>(111)</i>	657 <i>(74.2)</i>	821 <i>(92.8)</i>	985 <i>(111)</i>	-	-	
Solid Shaft OHL lbs <i>(N)</i>	308 <i>(1370)</i>	353 <i>(1570)</i>	387 <i>(1720)</i>	407 <i>(1810)</i>	441 <i>(1960)</i>	486 <i>(2160)</i>	508 <i>(2260)</i>	528 <i>(2350)</i>	573 <i>(2550)</i>	618 <i>(2750)</i>	638 <i>(2840)</i>	-	-	
Input Power HP <i>(kW)</i>	-	-	-	-	-	-	-	-	-	-	-	0.268 <i>(0.200)</i>	0.268 <i>(0.200)</i>	1330
Output Torque in-lbs <i>(N-m)</i>	-	-	-	-	-	-	-	-	-	-	-	657 <i>(74.2)</i>	821 <i>(92.8)</i>	
Solid Shaft OHL lbs <i>(N)</i>	-	-	-	-	-	-	-	-	-	-	-	661 <i>(2940)</i>	683 <i>(3040)</i>	
Input Power HP <i>(kW)</i>	-	-	-	-	-	-	-	-	-	-	-	-	-	1340
Output Torque in-lbs <i>(N-m)</i>	-	-	-	-	-	-	-	-	-	-	-	-	-	
Solid Shaft OHL lbs <i>(N)</i>	-	-	-	-	-	-	-	-	-	-	-	-	-	
Input Power HP <i>(kW)</i>	2.06 <i>(1.54)</i>	2.06 <i>(1.54)</i>	2.06 <i>(1.54)</i>	2.06 <i>(1.54)</i>	2.06 <i>(1.54)</i>	2.06 <i>(1.54)</i>	2.06 <i>(1.54)</i>	2.06 <i>(1.54)</i>	1.07 <i>(0.800)</i>	1.07 <i>(0.800)</i>	1.07 <i>(0.800)</i>	-	-	1420
Output Torque in-lbs <i>(N-m)</i>	316 <i>(35.7)</i>	443 <i>(50.0)</i>	632 <i>(71.4)</i>	759 <i>(85.7)</i>	948 <i>(107)</i>	1260 <i>(143)</i>	1580 <i>(179)</i>	1900 <i>(214)</i>	1310 <i>(148)</i>	1640 <i>(186)</i>	1970 <i>(223)</i>	-	-	
Solid Shaft OHL lbs <i>(N)</i>	463 <i>(2060)</i>	517 <i>(2300)</i>	585 <i>(2600)</i>	618 <i>(2750)</i>	661 <i>(2940)</i>	717 <i>(3190)</i>	760 <i>(3380)</i>	805 <i>(3580)</i>	859 <i>(3820)</i>	904 <i>(4020)</i>	937 <i>(4170)</i>	-	-	

Speed Reducers Selection Tables

C-Face Frame Size Selection Tables

Dimensions:	Frame Size	Page	Frame Size	Page
	1100	2.26	1400	2.29
	1200	2.27	1500	2.30
	1300	2.28	1600	2.31

Output RPM	14.6	11.7	8.75	7.29	5.83	4.86	3.65	2.92	2.43	1.94	1.46	1.22	Frame Size
Ratio	120	150	200	240	300	360	480	600	720	900	1200	1440	
Input Power HP	-	-	-	-	-	-	-	-	-	-	-	-	1120
(kW)	-	-	-	-	-	-	-	-	-	-	-	-	
Output Torque in-lbs <i>(N-m)</i>	-	-	-	-	-	-	-	-	-	-	-	-	
Solid Shaft OHL lbs <i>(N)</i>	-	-	-	-	-	-	-	-	-	-	-	-	
Input Power HP	-	-	-	-	-	-	-	-	-	-	-	-	1220
(kW)	-	-	-	-	-	-	-	-	-	-	-	-	
Output Torque in-lbs <i>(N-m)</i>	-	-	-	-	-	-	-	-	-	-	-	-	
Solid Shaft OHL lbs <i>(N)</i>	-	-	-	-	-	-	-	-	-	-	-	-	
Input Power HP	0.134	0.134	0.134	0.118	-	-	-	-	-	-	-	-	1230
(kW)	(0.100)	(0.100)	(0.100)	(0.0881)	-	-	-	-	-	-	-	-	
Output Torque in-lbs <i>(N-m)</i>	493 <i>(55.7)</i>	616 <i>(69.6)</i>	821 <i>(92.8)</i>	868 <i>(98.1)</i>	-	-	-	-	-	-	-	-	
Solid Shaft OHL lbs <i>(N)</i>	407 <i>(1810)</i>	407 <i>(1810)</i>	407 <i>(1810)</i>	407 <i>(1810)</i>	-	-	-	-	-	-	-	-	
Input Power HP	-	-	-	-	-	-	-	-	-	-	-	-	1320
(kW)	-	-	-	-	-	-	-	-	-	-	-	-	
Output Torque in-lbs <i>(N-m)</i>	-	-	-	-	-	-	-	-	-	-	-	-	
Solid Shaft OHL lbs <i>(N)</i>	-	-	-	-	-	-	-	-	-	-	-	-	
Input Power HP	0.268	0.125	0.125	0.125	-	-	-	-	-	-	-	-	1330
(kW)	(0.200)	(0.0933)	(0.0933)	(0.0933)	-	-	-	-	-	-	-	-	
Output Torque in-lbs <i>(N-m)</i>	985 <i>(111)</i>	574 <i>(64.9)</i>	766 <i>(86.5)</i>	919 <i>(104)</i>	-	-	-	-	-	-	-	-	
Solid Shaft OHL lbs <i>(N)</i>	695 <i>(3090)</i>	695 <i>(3090)</i>	695 <i>(3090)</i>	695 <i>(3090)</i>	-	-	-	-	-	-	-	-	
Input Power HP	-	-	-	-	0.134	0.134	0.125	0.0999	0.0833	0.0666	0.0500	0.0416	1340
(kW)	-	-	-	-	(0.100)	(0.100)	(0.0932)	(0.0745)	(0.0621)	(0.0497)	(0.0373)	(0.0311)	
Output Torque in-lbs <i>(N-m)</i>	-	-	-	-	1160 <i>(131)</i>	1390 <i>(157)</i>	1730 <i>(195)</i>	1730 <i>(195)</i>	1730 <i>(195)</i>	1730 <i>(195)</i>	1730 <i>(195)</i>	1730 <i>(195)</i>	
Solid Shaft OHL lbs <i>(N)</i>	-	-	-	-	695 <i>(3090)</i>	695 <i>(3090)</i>	695 <i>(3090)</i>	695 <i>(3090)</i>	695 <i>(3090)</i>	695 <i>(3090)</i>	695 <i>(3090)</i>	695 <i>(3090)</i>	
Input Power HP	-	-	-	-	-	-	-	-	-	-	-	-	1420
(kW)	-	-	-	-	-	-	-	-	-	-	-	-	
Output Torque in-lbs <i>(N-m)</i>	-	-	-	-	-	-	-	-	-	-	-	-	
Solid Shaft OHL lbs <i>(N)</i>	-	-	-	-	-	-	-	-	-	-	-	-	

Speed Reducers

Selection Tables

C-Face Frame Size Selection Tables

Dimensions: Frame Size	Page	Frame Size	Page
1100	2.26	1400	2.29
1200	2.27	1500	2.30
1300	2.28	1600	2.31

Output RPM 14.6 thru 1.22 continued on next page.

Output RPM	350	250	175	146	117	87.5	70.0	58.3	43.8	35.0	29.2	21.9	17.5	Frame Size
Ratio	5	7	10	12	15	20	25	30	40	50	60	80	100	
Input Power HP	-	-	-	-	-	-	-	-	-	-	-	0.536	0.536	1430
<i>(kW)</i>	-	-	-	-	-	-	-	-	-	-	-	(0.400)	(0.400)	
Output Torque in-lbs <i>(N-m)</i>	-	-	-	-	-	-	-	-	-	-	-	1310 <i>(148)</i>	1640 <i>(186)</i>	
Solid Shaft OHL lbs <i>(N)</i>	-	-	-	-	-	-	-	-	-	-	-	960 <i>(4270)</i>	980 <i>(4360)</i>	
Input Power HP	-	-	-	-	-	-	-	-	-	-	-	-	-	1440
<i>(kW)</i>	-	-	-	-	-	-	-	-	-	-	-	-	-	
Output Torque in-lbs <i>(N-m)</i>	-	-	-	-	-	-	-	-	-	-	-	-	-	
Solid Shaft OHL lbs <i>(N)</i>	-	-	-	-	-	-	-	-	-	-	-	-	-	
Input Power HP	2.06	2.06	2.06	2.06	2.06	2.06	2.06	2.06	2.06	2.06	2.06	-	-	1520
<i>(kW)</i>	(1.54)	(1.54)	(1.54)	(1.54)	(1.54)	(1.54)	(1.54)	(1.54)	(1.54)	(1.54)	(1.54)	-	-	
Output Torque in-lbs <i>(N-m)</i>	316 <i>(35.7)</i>	443 <i>(50.0)</i>	632 <i>(71.4)</i>	759 <i>(85.7)</i>	948 <i>(107)</i>	1260 <i>(143)</i>	1580 <i>(179)</i>	1900 <i>(214)</i>	2530 <i>(286)</i>	3160 <i>(357)</i>	3790 <i>(429)</i>	-	-	
Solid Shaft OHL lbs <i>(N)</i>	661 <i>(2940)</i>	749 <i>(3330)</i>	839 <i>(3730)</i>	892 <i>(3970)</i>	949 <i>(4220)</i>	1040 <i>(4610)</i>	1100 <i>(4900)</i>	1160 <i>(5150)</i>	1250 <i>(5540)</i>	1310 <i>(5830)</i>	1360 <i>(6030)</i>	-	-	
Input Power HP	-	-	-	-	-	-	-	-	-	-	-	-	-	1521
<i>(kW)</i>	-	-	-	-	-	-	-	-	-	-	-	-	-	
Output Torque in-lbs <i>(N-m)</i>	-	-	-	-	-	-	-	-	-	-	-	-	-	
Solid Shaft OHL lbs <i>(N)</i>	-	-	-	-	-	-	-	-	-	-	-	-	-	
Input Power HP	-	-	-	-	-	-	-	-	-	-	-	-	-	1522
<i>(kW)</i>	-	-	-	-	-	-	-	-	-	-	-	-	-	
Output Torque in-lbs <i>(N-m)</i>	-	-	-	-	-	-	-	-	-	-	-	-	-	
Solid Shaft OHL lbs <i>(N)</i>	-	-	-	-	-	-	-	-	-	-	-	-	-	
Input Power HP	-	-	-	-	-	-	-	-	-	-	-	1.07	1.07	1530
<i>(kW)</i>	-	-	-	-	-	-	-	-	-	-	-	(0.800)	(0.800)	
Output Torque in-lbs <i>(N-m)</i>	-	-	-	-	-	-	-	-	-	-	-	2630 <i>(297)</i>	3280 <i>(371)</i>	
Solid Shaft OHL lbs <i>(N)</i>	-	-	-	-	-	-	-	-	-	-	-	1380 <i>(6130)</i>	1400 <i>(6230)</i>	
Input Power HP	-	-	-	-	-	-	-	-	2.06	2.06	2.06	2.06	-	1531
<i>(kW)</i>	-	-	-	-	-	-	-	-	(1.54)	(1.54)	(1.54)	(1.54)	-	
Output Torque in-lbs <i>(N-m)</i>	-	-	-	-	-	-	-	-	2530 <i>(286)</i>	3160 <i>(357)</i>	3790 <i>(429)</i>	5060 <i>(571)</i>	-	
Solid Shaft OHL lbs <i>(N)</i>	-	-	-	-	-	-	-	-	1250 <i>(5540)</i>	1310 <i>(5830)</i>	1360 <i>(6030)</i>	1380 <i>(6130)</i>	-	

Speed Reducers
Selection Tables

C-Face Frame Size Selection Tables

Dimensions: Frame Size	Page	Frame Size	Page
1100	2.26	1400	2.29
1200	2.27	1500	2.30
1300	2.28	1600	2.31

Output RPM	14.6	11.7	8.75	7.29	5.83	4.86	3.65	2.92	2.43	1.94	1.46	1.22	Frame Size
Ratio	120	150	200	240	300	360	480	600	720	900	1200	1440	
Input Power HP	0.536	0.250	0.250	0.250	-	-	-	-	-	-	-	-	1430
(kW)	(0.400)	(0.187)	(0.187)	(0.187)	-	-	-	-	-	-	-	-	
Output Torque in-lbs (N-m)	1970 (223)	1150 (130)	1530 (173)	1840 (208)	-	-	-	-	-	-	-	-	
Solid Shaft OHL lbs (N)	980 (4360)	980 (4360)	980 (4360)	980 (4360)	-	-	-	-	-	-	-	-	
Input Power HP	-	-	-	-	0.268	0.268	0.250	0.200	0.167	0.133	0.0999	0.0833	1440
(kW)	-	-	-	-	(0.200)	(0.200)	(0.186)	(0.149)	(0.124)	(0.0994)	(0.0745)	(0.0621)	
Output Torque in-lbs (N-m)	-	-	-	-	2320 (262)	2780 (314)	3460 (390)	3460 (390)	3460 (390)	3460 (390)	3460 (390)	3460 (390)	
Solid Shaft OHL lbs (N)	-	-	-	-	980 (4360)	980 (4360)	980 (4360)	980 (4360)	980 (4360)	980 (4360)	980 (4360)	980 (4360)	
Input Power HP	-	-	-	-	-	-	-	-	-	-	-	-	1520
(kW)	-	-	-	-	-	-	-	-	-	-	-	-	
Output Torque in-lbs (N-m)	-	-	-	-	-	-	-	-	-	-	-	-	
Solid Shaft OHL lbs (N)	-	-	-	-	-	-	-	-	-	-	-	-	
Input Power HP	-	-	-	-	-	-	-	-	-	-	-	-	1521
(kW)	-	-	-	-	-	-	-	-	-	-	-	-	
Output Torque in-lbs (N-m)	-	-	-	-	-	-	-	-	-	-	-	-	
Solid Shaft OHL lbs (N)	-	-	-	-	-	-	-	-	-	-	-	-	
Input Power HP	-	-	-	-	-	-	-	-	-	-	-	-	1522
(kW)	-	-	-	-	-	-	-	-	-	-	-	-	
Output Torque in-lbs (N-m)	-	-	-	-	-	-	-	-	-	-	-	-	
Solid Shaft OHL lbs (N)	-	-	-	-	-	-	-	-	-	-	-	-	
Input Power HP	1.07	0.500	0.500	0.500	-	-	-	-	-	-	-	-	1530
(kW)	(0.800)	(0.373)	(0.373)	(0.373)	-	-	-	-	-	-	-	-	
Output Torque in-lbs (N-m)	3940 (445)	2300 (260)	3060 (346)	3680 (415)	-	-	-	-	-	-	-	-	
Solid Shaft OHL lbs (N)	1400 (6230)	1400 (6230)	1400 (6230)	1400 (6230)	-	-	-	-	-	-	-	-	
Input Power HP	-	-	-	-	-	-	-	-	-	-	-	-	1531
(kW)	-	-	-	-	-	-	-	-	-	-	-	-	
Output Torque in-lbs (N-m)	-	-	-	-	-	-	-	-	-	-	-	-	
Solid Shaft OHL lbs (N)	-	-	-	-	-	-	-	-	-	-	-	-	

Speed Reducers

Selection Tables

Dimensions: Frame Size	Page	Frame Size	Page
1100	2.26	1400	2.29
1200	2.27	1500	2.30
1300	2.28	1600	2.31

C-Face Frame Size Selection Tables

Output RPM 14.6 thru 1.22 continued on next page.

Output RPM	350	250	175	146	117	87.5	70.0	58.3	43.8	35.0	29.2	21.9	17.5	Frame Size
Ratio	5	7	10	12	15	20	25	30	40	50	60	80	100	
Input Power HP	-	-	-	-	0.536	0.536	0.468	0.375	0.312	0.250	0.187	0.156	1540	
(kW)	-	-	-	-	(0.400)	(0.400)	(0.349)	(0.279)	(0.233)	(0.186)	(0.140)	(0.116)		
Output Torque in-lbs <i>(N-m)</i>	-	-	-	-	4640 <i>(524)</i>	5560 <i>(629)</i>	6480 <i>(732)</i>	6480 <i>(732)</i>	6480 <i>(732)</i>	6480 <i>(732)</i>	6480 <i>(732)</i>	6480 <i>(732)</i>		
Solid Shaft OHL lbs <i>(N)</i>	-	-	-	-	1400 <i>(6230)</i>	1400 <i>(6230)</i>	1400 <i>(6230)</i>	1400 <i>(6230)</i>	1400 <i>(6230)</i>	1400 <i>(6230)</i>	1400 <i>(6230)</i>	1400 <i>(6230)</i>		
Input Power HP	-	-	-	-	-	-	-	-	-	-	-	-	1630	
(kW)	-	-	-	-	-	-	-	-	-	-	-	-		
Output Torque in-lbs <i>(N-m)</i>	-	-	-	-	-	-	-	-	-	-	-	-		
Solid Shaft OHL lbs <i>(N)</i>	-	-	-	-	-	-	-	-	-	-	-	-		
Input Power HP	-	-	-	-	-	-	-	-	-	-	-	-	1631	
(kW)	-	-	-	-	-	-	-	-	-	-	-	-		
Output Torque in-lbs <i>(N-m)</i>	-	-	-	-	-	-	-	-	-	-	-	-		
Solid Shaft OHL lbs <i>(N)</i>	-	-	-	-	-	-	-	-	-	-	-	-		
Input Power HP	-	-	-	-	-	-	-	-	-	-	-	-	1632	
(kW)	-	-	-	-	-	-	-	-	-	-	-	-		
Output Torque in-lbs <i>(N-m)</i>	-	-	-	-	-	-	-	-	-	-	-	-		
Solid Shaft OHL lbs <i>(N)</i>	-	-	-	-	-	-	-	-	-	-	-	-		
Input Power HP	-	-	-	-	-	-	-	-	-	-	-	-	1633	
(kW)	-	-	-	-	-	-	-	-	-	-	-	-		
Output Torque in-lbs <i>(N-m)</i>	-	-	-	-	-	-	-	-	-	-	-	-		
Solid Shaft OHL lbs <i>(N)</i>	-	-	-	-	-	-	-	-	-	-	-	-		
Input Power HP	-	-	-	-	-	-	-	-	-	-	-	-	1634	
(kW)	-	-	-	-	-	-	-	-	-	-	-	-		
Output Torque in-lbs <i>(N-m)</i>	-	-	-	-	-	-	-	-	-	-	-	-		
Solid Shaft OHL lbs <i>(N)</i>	-	-	-	-	-	-	-	-	-	-	-	-		
Input Power HP	-	-	-	-	1.07	1.07	0.948	0.758	0.632	0.505	0.379	0.316	1640	
(kW)	-	-	-	-	(0.800)	(0.800)	(0.707)	(0.566)	(0.471)	(0.377)	(0.283)	(0.236)		
Output Torque in-lbs <i>(N-m)</i>	-	-	-	-	9270 <i>(1048)</i>	11100 <i>(1257)</i>	13100 <i>(1481)</i>	13100 <i>(1481)</i>	13100 <i>(1481)</i>	13100 <i>(1481)</i>	13100 <i>(1481)</i>	13100 <i>(1481)</i>		
Solid Shaft OHL lbs <i>(N)</i>	-	-	-	-	2210 <i>(9810)</i>	2210 <i>(9810)</i>	2210 <i>(9810)</i>	2210 <i>(9810)</i>	2210 <i>(9810)</i>	2210 <i>(9810)</i>	2210 <i>(9810)</i>	2210 <i>(9810)</i>		

Speed Reducers Selection Tables

This page intentionally left blank.

Speed
Reducers

Selection
Tables

Quill Dimensions

Frame Size 1100 RNYX-1120Y

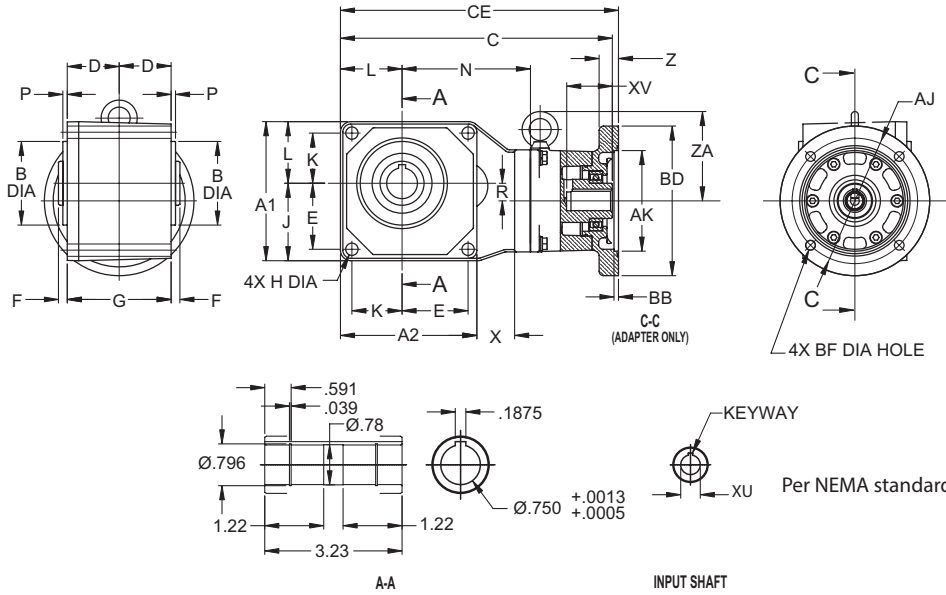

All dimensions are in inches (mm)

Model	A1	A2	B min	B max	D	E	F	G	H	J	K	L	N	P	R	X
1120Y	3.54 (90)	3.47 (88)	2.046 (51.97)	2.0472 (52)	1.30 (33)	1.65 (42)	0.31 (8)	2.60 (66)	0.26 (6.6)	1.97 (50)	1.26 (32)	1.57 (40)	3.23 (82)	0.24 (6)	0.79 (20)	0.87 (22)

Model	Ratio	NEMA Frame	CE	C	AK	BD	AJ	BF	Z	BB	ZA	Wt. (lbs.)
RNYX-1120Y	5~60	56C	7.87 (200)	7.56 (192)	4.5 (114.3)	6.69 (170)	5.875 (149.2)	0.43 (11)	0.39 (10)	0.22 (5.5)	-	8 (3.5)

Model	NEMA Frame	XU	XU Tolerance	XV
RNYX-1120Y	56C	0.625	+0.0017 / +0.0009	1.82

Speed Reducers
Dimensions

Quill Dimensions

Frame Size 1200 RNYX-1220/30Y

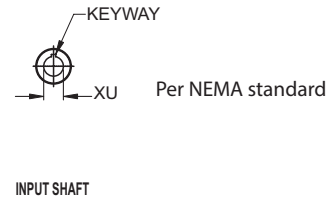
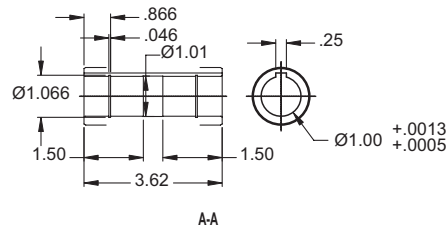
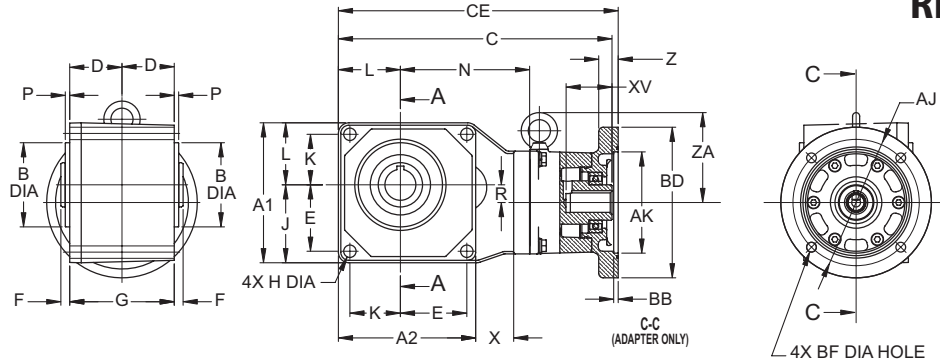

All dimensions are in inches (mm)

Model	A1	A2	B min	B max	D	E	F	G	H	J	K	L	N	P	R	X
1220Y	4.53 (115)	4.45 (113)	3.0697 (77.97)	3.0709 (78)	1.46 (37)	2.24 (57)	0.35 (9)	2.91 (74)	0.35 (9)	2.60 (66)	1.57 (40)	1.93 (49)	3.78 (96)	0.20 (5)	1.10 (28)	0.79 (20)
1230Y	5.00 (127)	5.00 (127)			1.61 (41)	2.56 (65)		3.23 (82)		2.99 (76)		2.01 (51)	3.74 (95)			

Model	Ratio	NEMA Frame	CE	C	AK	BD	AJ	BF	Z	BB	ZA	Wt. (lbs.)
RNYX-1220Y	5~60	56C	9.17 (233)	8.86 (225)	4.50 (114.3)	6.69 (170)	5.875 (149.2)	0.43 (11)	0.39 (10)	0.22 (5.5)	-	11 (5)
RNYX-1230Y	80~120		8.82 (224)	8.50 (216)						0.22 (5.5)		

Model	NEMA Frame	XU	XU Tolerance	XV
RNYX-1220Y	56C	0.625	+0.0017 / +0.0009	1.85
RNYX-1230Y				1.82

Speed Reducers

Dimensions

Quill Dimensions

Frame Size 1300 RNYX-1320/30/40Y

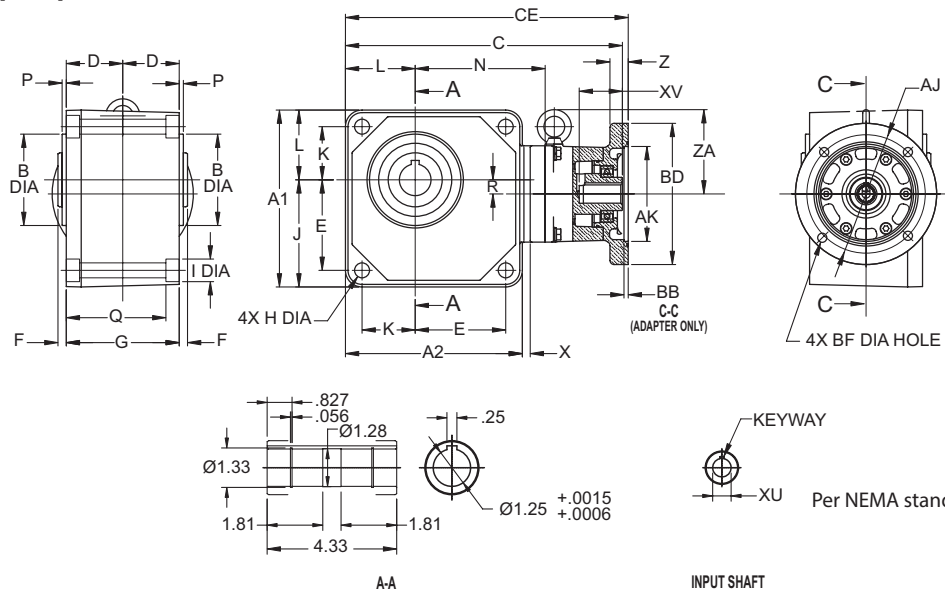

All dimensions are in inches (mm).

Model	A1	A2	B min	B max	D	E	F	G	H	J	K	L	N	P	R	X	
1320Y	5.20 (132)	5.12 (130)	3.3451 (84.965)	3.3464 (85.000)	1.81 (46)	2.44 (62)	0.35 (9)	3.62 (92)	0.43 (11)	2.91 (74)	1.81 (46)	2.28 (58)	4.69 (119)	0.20 (5)	1.08 (27.5)	1.34 (34)	
1330Y	5.98 (152)	5.98 (152)				3.11 (79)				3.62 (92)	3.62 (92)	1.85 (47)	2.36 (60)		4.25 (108)	0.43 (11)	0.14 (4)
1340Y						5.16 (131)				5.16 (131)	0.35 (9)	1.04 (27)					

Model	Ratio	NEMA Frame	CE	C	AK	BD	AJ	BF	Z	BB	ZA	Wt. (lbs.)
RNYX-1320Y	5~60	56C	10.67 (271)	10.39 (264)	4.500 (114.3)	6.69 (170)	5.875 (149.2)	0.43 (11)	0.87 (22)	0.20 (5.1)	4.53 (115)	18 (8)
RNYX-1320Y	5~30	143TC	10.7 (271)	10.4 (264)					0.39 (10)	0.22 (5.5)	-	14 (7)
RNYX-1330Y	80~240	56C	10.1 (256)	9.76 (248)								15 (7)
RNYX-1340Y	300~720		10.6 (269)	10.3 (261)								15 (7)

Model	NEMA Frame	XU	XU Tolerance	XV
RNYX-1320Y	56C	0.625	+0.0015 / +0.0008	1.93
RNYX-1320Y	143TC	0.875	+0.0019/ +0.001	
RNYX-1330Y	56C	0.625	+0.0017 / +0.0009	1.85
RNYX-1340Y				1.82

Speed Reducers
Dimensions

Quill Dimensions

Frame Size 1400 RNYX-1420/30/40Y

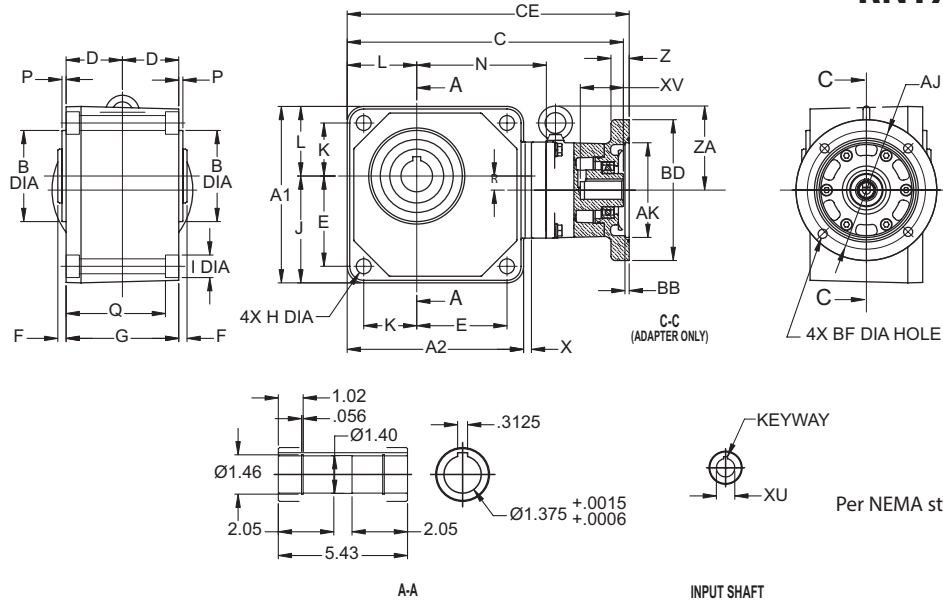

All dimensions are in inches (mm).

Model	A1	A2	B min	B max	D	E	F	G	H	J	K	L	N	P	R	X
1420Y	6.22 (158)	6.10 (155)	3.7388 (94.965)	3.740 (95.000)	2.32 (59)	2.95 (75)	0.39	4.65 (118)	0.55 (14)	3.46 (88)	2.24 (57)	2.76 (70)	5.75 (146)	0.20 (5)	0.79 (20)	1.69 (43)
1430Y	7.01 (178)	7.01 (178)				3.62 (92)				4.25 (108)	2.13 (54)		5.12 (130)		0.55 (14)	0.31 (8)
1440Y						6.42 (163)				0.43 (11)	1.73 (44)					

Model	Ratio	NEMA Frame	CE	C	AK	BD	AJ	BF	Z	BB	ZA	Wt. (lbs.)
RNYX-1420Y	5~60	56C~145TC	12.4 (316)	12.1 (308)	4.500 (114.3)	6.69 (170)	5.875 (149.2)	0.43 (11)	0.87 (22)	0.20 (5.1)	4.53 (115)	28 (13)
RNYX-1430Y	80~240	56C	11.6 (294)	11.3 (287)					0.39 (10)	0.22 (5.5)	-	26 (12)
RNYX-1440Y	300~1440		12.6 (321)	12.3 (313)								

Model	NEMA Frame	XU	XU Tolerance	XV
RNYX-1420Y	56C	0.625	+0.0015/ +0.0008	2.01
RNYX-1420Y	143TC	0.875	+0.0019/ +0.001	2.05
RNYX-1430Y	56C	0.625	+0.0015/ +0.0008	1.93
RNYX-1440Y			+0.0017/+0.0009	1.85

Speed Reducers

Dimensions

Quill Dimensions

Frame Size 1500 RNYX-1530/31/40Y

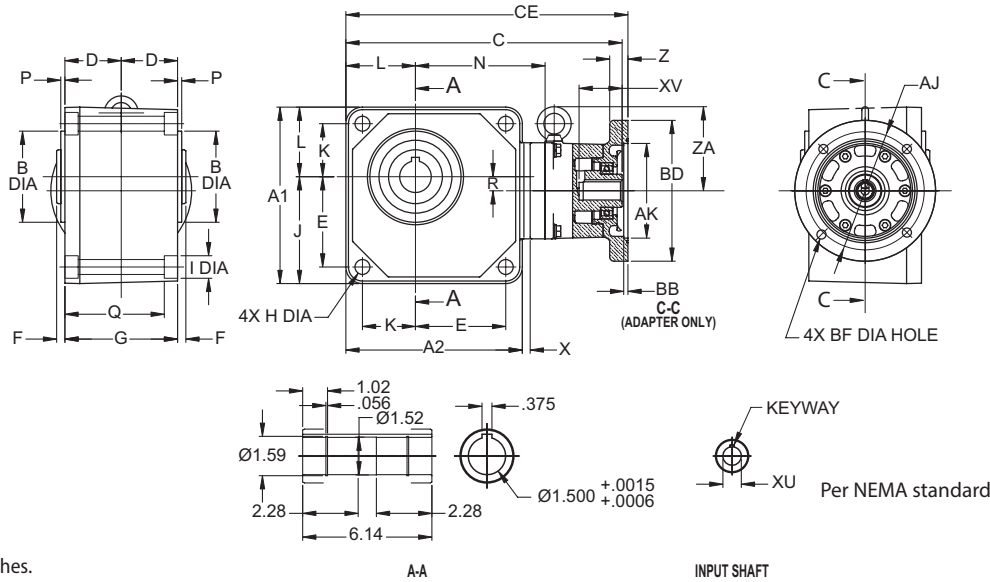

All dimensions are in inches.

Model	A1	A2	B min	B max	D	E	F	G	H	J	K	L	N	P	R	X
1530/31Y	8.39 (213)	8.39 (213)	4.32930 (109.965)	4.3307 (110.000)	2.68 (68)	4.29 (109)	0.39 (10)	5.35 (136)	0.71 (18)	5.08 (129)	2.52 (64)	3.31 (84)	6.18 (157)	0.20 (5)	0.67 (17)	0.37 (10)
1540Y													7.76 (197)		0.55 (14)	2.13 (54)

Model	Ratio	NEMA Frame	CE	C	AK	BD	AJ	BF	Z	BB	ZA	Wt. (lbs.)
RNYX-1530Y	80~240	56C	13.4 (341)	13.1 (333)	4.500 (114.3)	6.69 (170)	5.875 (149)	0.43 (11)	0.87 (22)	0.2 -	5.12 (130)	43 (20)
RNYX-1530Y	80~120	143TC~145TC		13.1 (334)								45 (21)
RNYX-1531Y	40 ~ 80											
RNYX-1540Y	300~1440	56C	14.8 (375)	14.5 (368)								

Model	NEMA Frame	XU	XU Tolerance	XV
RNYX-1530Y	56C	0.625	+0.0015/+0.0008	2.01
RNYX-1530Y	143TC	0.875	+0.00019/ +0.001	2.05
RNYX-1531Y	145TC			
RNYX-1540Y	56C	0.625	+0.0015/+0.0008	1.93

Quill Dimensions

Frame Size 1600 RNYX-1630/31/32/40Y

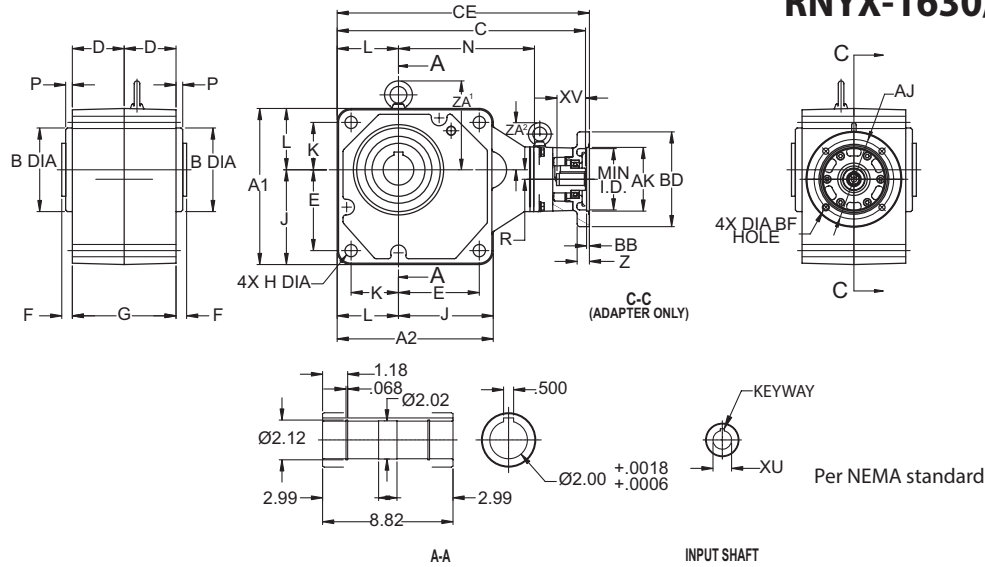

All dimensions are in inches.

Model	A1	A2	B min	B max	D	E	F	G	H	J	K	L	N	P	R	ZA ¹
1630/31/32Y	11.0 (280)	11.0 (280)	5.9039 (149.960)	5.9055 (150)	3.66 (93)	5.71 (145)	0.75 (19)	7.32 (186)	0.87 (22)	6.69 (170)	3.35 (85)	4.33 (110)	8.37 (213)	0.5 (12)	1.06 (27)	6.26 159
1640Y													9.29 (236)		0.67 (17)	

Model	Ratio	NEMA Frame	CE	C	AK	BD	AJ	BF	Z	BB	ZA ²	Wt. (lbs.)
RNYX-1630Y	10 ~120	143TC~145TC	18.1 (461)	17.9 (454)	4.500 (114.3)	6.69 (170)	5.875 (149.2)	0.43 (11)	0.91 (23)	0.20 (5.1)	-	110 (50)
RNYX-1630Y		182TC~184TC	18.4 (469)	17.7 (450)	8.500 (215.9)	9.02 (229)	5.875 (184.2)	0.55 (14)	0.87 (22)			115 (52)
RNYX-1631Y	150~240	56C	18.1 (461)	17.9 (454)	4.500 (114.3)	6.69 (170)	5.875 (149.2)	0.43 (11)	0.91 (23)			103 (47)
RNYX-1631Y		143TC~145TC	18.4 (469)	17.7 (450)	8.500 (215.9)	9.02 (229)	5.875 (184.2)	0.55 (14)	0.87 (22)			107 (49)
RNYX-1631Y		182TC~184TC	18.4 (469)	17.7 (450)	8.500 (215.9)	9.02 (229)	5.875 (184.2)	0.55 (14)	0.87 (22)			115 (52)
RNYX-1632Y	10~60											
RNYX-1640Y	300~1440	56C	17.6 (446)	17.2 (438)	4.500 (114.3)	6.69 (170)	5.875 (149.2)	0.43 (11)			6.97 (117)	127 (57)
RNYX-1640Y	300~720	143TC~145TC										

Model	NEMA Frame	XU	XU Tolerance	XV
RNYX-1630Y	143TC	0.875	+0.0018/ +0.0009	2.36
RNYX-1630Y	182TC	1.125	+0.002/ +0.0011	2.16
RNYX-1631Y	56C	0.625	+0.0016/ +0.0009	1.86
RNYX-1631Y	143TC	0.875	+0.0018/ +0.0009	2.36
RNYX-1631Y	182TC	1.125	+0.002/ +0.0011	2.16
RNYX-1632Y				
RNYX-1640Y	56C	0.625	+0.0015/ +0.0008	1.82
RNYX-1640Y	143TC	0.875	+0.0019/ +0.001	1.92

C-Face Dimensions

Frame Size 1100 RNYJ-1120Y

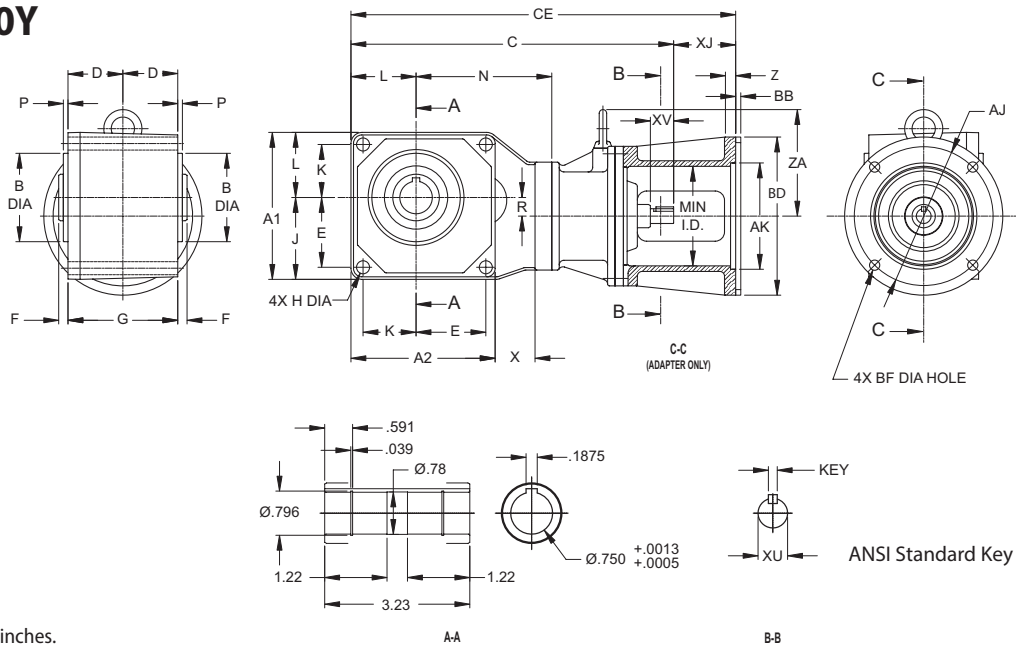

All dimensions are in inches.

Model	A1	A2	B min	B max	D	E	F	G	H	J	K	L	N	P	R	X
1120Y	3.54 (90)	3.46 (88)	2.0460 (51.970)	2.0472 (52.000)	1.3 (33)	1.65 (42)	0.31 (8)	2.6 (66)	0.26 (7)	1.97 (50)	1.26 (32)	1.57 (40)	3.23 (82)	0.24 (6)	0.79 (20)	0.87 (22)

Model	Ratio	NEMA Frame	CE	C	XJ	AK	BD	AJ	BF	Z	BB	Min. ID	ZA	Wt. (lbs.)
RNYJ-1120Y	5~60	42C	10.7 (272)	8.94 (227)	1.78 (45)	3.00 (76.2)	4.33 (110)	3.75 (95.3)	0.28 (7)	0.47 (12)	-	2.44 (62)	-	13 (6)
RNYJ-1120Y		48C	11.1 (282)		2.16 (55)									
RNYJ-1120Y	5~30	56C	11.5 (292)		2.56 (65)	4.500 (114.3)	6.69 (170)	5.875 (149.2)	0.43 (11)			3.15 (80)		15 (7)

Model	XU	XU Tolerance	XV
RNYJ-1120Y	0.5	+0/-0.0004	.98

Speed Reducers
Dimensions

C-Face Dimensions

Frame Size 1200 RNYJ-1220/30Y

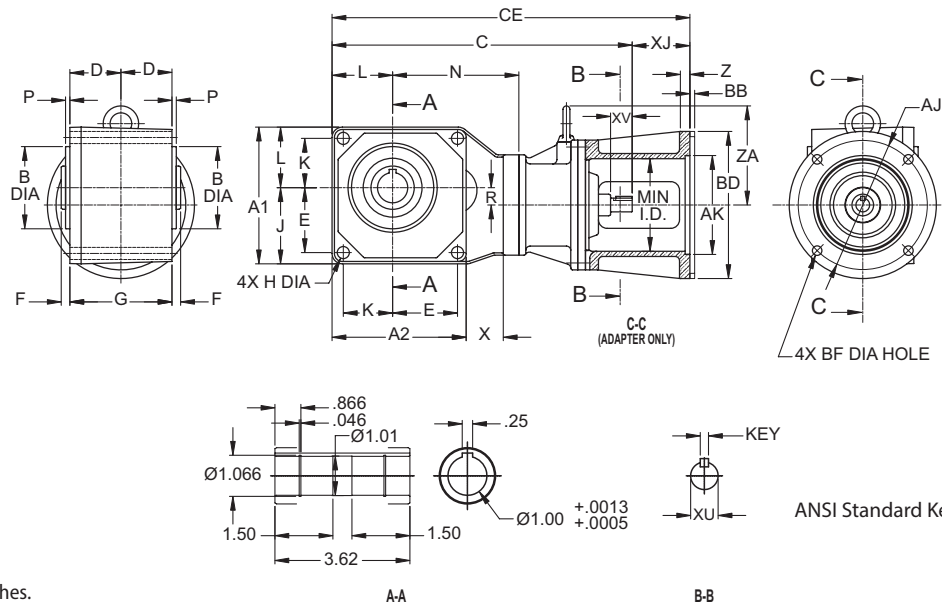

All dimensions are in inches.

Model	A1	A2	B min	B max	D	E	F	G	H	J	K	L	N	P	R	X
1220Y	4.53 (115)	4.45 (113)	3.0697 (77.97)	3.0709 (78)	1.46 (37)	2.24 (57)	0.35 (9)	2.91 (74)	0.35 (9)	2.6 (66)	1.57 (40)	1.93 (49)	3.8 (96)	0.2 (5)	1.1 (28)	0.79 (20)
1230Y	5 (127)	5 (127)			1.61 (47)	2.56 (65)		3.23 (82)		2.99 (76)		2.01 (51)	3.7 (95)		0.51 (13)	0.31 (8)

Model	Ratio	NEMA Frame	CE	C	XJ	AK	BD	AJ	BF	Z	BB	Min. ID	ZA	Wt. (lbs.)
RNYJ-1220Y	5~60	48C	12.4 (315)	10.2 (260)	2.16 (55)	3.00 (76.2)	4.33 (110)	3.75 (95.3)	0.28 (7)	0.47 (12)	-	2.44 (62)	-	16 (7)
RNYJ-1220Y		56C	12.8 (325)		2.56 (65)	4.500 (114.3)	6.69 (170)	5.875 (149.2)	0.43 (11)			3.15 (80)		18 (8)
RNYJ-1220Y		143TC				4.500 (114.0)		5.875 (149)						
RNYJ-1230Y	80~240	42C	11.7 (296)	9.88 (251)	1.78 (45)	3.00 (76.2)	4.33 (110)	3.75 (95.3)	0.28 (7)	0.47 (12)	-	2.44 (62)	-	16 (7)
RNYJ-1230Y		48C	12.0 (306)		2.16 (55)	4.500 (114.3)	6.69 (170)	5.875 (149.2)	0.43 (11)			3.15 (80)		18 (8)
RNYJ-1230Y		56C	12.4 (316)		2.56 (65)	4.500 (114.3)	6.69 (170)	5.875 (149.2)	0.43 (11)					

Model	XU	XU Tolerance	XV
RNYJ-1220Y RNYJ-1230Y	0.5	+0/ -0.0004	.98

Speed Reducers

Dimensions

C-Face Dimensions

Frame Size 1300 RNYJ-1320/30/40Y

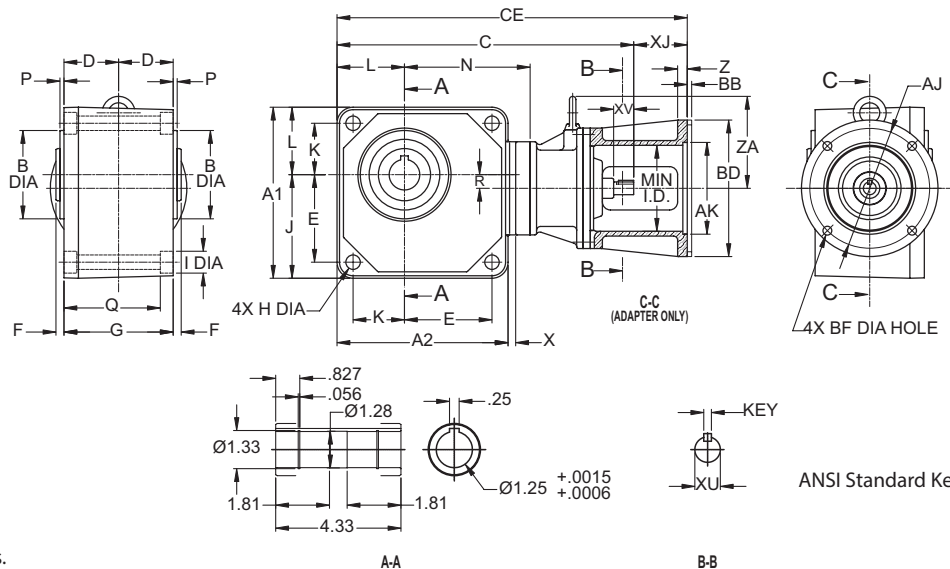

All dimensions are in inches.

Model	A1	A2	B min	B max	D	E	F	G	H	J	K	L	N	P	R	X
1320Y	5.20 (132)	5.12 (130)		3.3464 (85)		2.44 (62)				2.91 (74)	1.81 (46)	2.28 (58)	4.69 (119)		1.08 (27.5)	1.34 (34)
1330Y	5.98 (152)	5.98 (152)	3.3451 (84.965)	3.346 (85.000)	1.81 (46)	3.11 (79)	0.35 (9)	3.62 (92)	0.43 (11)	3.62 (92)	1.85 (47)	2.36 (60)	4.25 (108)	0.2 (5)	0.43 (11)	0.14 (4)
1340Y													5.16 (131)		0.35 (9)	1.04 (27)

Model	Ratio	NEMA Frame	CE	C	XJ	AK	BD	AJ	BF	Z	BB	Min. ID	ZA	Wt. (lbs.)
RNYJ-1320Y	5~60	56C	14.5 (369)	11.9 (302)	2.63 (67)	4.500 (114.3)	6.69 (170)	5.875 (149.2)	0.43 (11)	0.47 (12)	-	4.21 (107)	-	29 (13)
RNYJ-1320Y	5~30	143TC										2.44 (62)		20 (9)
RNYJ-1330Y	80~240	48C	13.3 (338)	11.1 (283)	2.16 (55)	3.00 (76.2)	4.33 (110)	5.875 (95.3)	0.28 (7)			3.15 (80)		21 (10)
RNYJ-1330Y		56C	13.7 (348)		2.56 (65)	4.500 (114.3)	6.69 (170)	5.875 (149.2)	0.43 (11)					
RNYJ-1340Y	300~1440	42C	13.7 (347)	11.7 (296)	2.02 (51)	3.00 (76.2)	4.33 (110)	3.750 (95.3)	0.28 (7)			2.44 (62)		20 (9)
RNYJ-1340Y	300~720	48C	13.8 (351)		2.16 (55)									
RNYJ-1340Y		56C	14.2 (361)		2.56 (65)	4.500 (114.3)	6.69 (170)	3.750 (149.2)	0.43 (11)	3.15 (80)	23 (11)			

Model	XU	XU Tolerance	XV
RNYJ-1320Y	0.625	+0/-0.0004	0.98
RNYJ-1330Y	0.5		
RNYJ-1340Y			

C-Face Dimensions

Frame Size 1400
RNYJ-1420/30/40Y

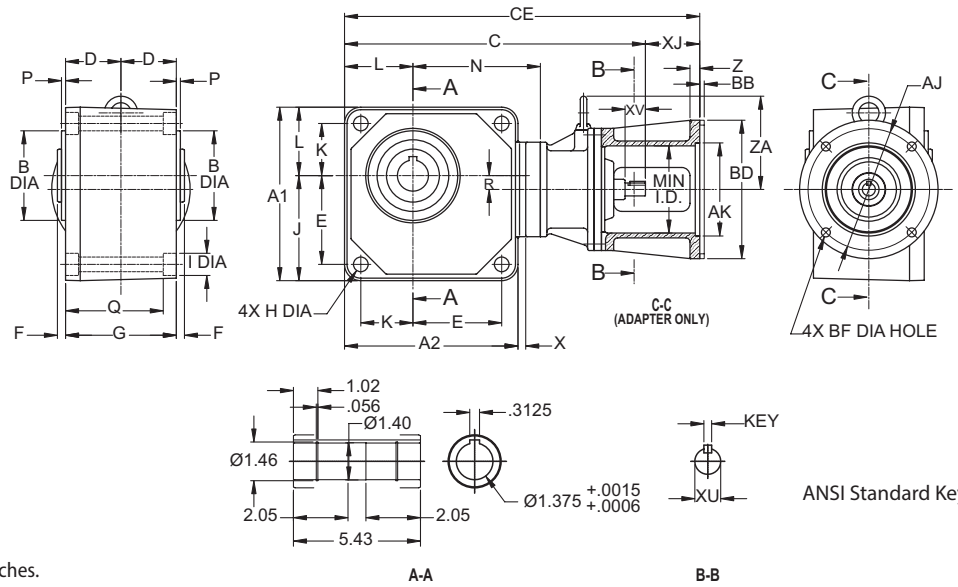

All dimensions are in inches.

Speed Reducers

Dimensions

Model	A1	A2	B min	B max	D	E	F	G	H	J	K	L	N	P	R	X
1420Y	6.22 (158)	6.1 (155)	3.7388 (94.965)	3.740 (95.000)	2.32 (59)	2.95 (75)	0.39 (10)	4.65 (118)	0.55 (14)	3.46 (88)	2.24 (57)	2.76 (70)	5.75 (146)	0.2 (5)	0.79 (20)	1.69 (43)
1430Y	7.01 (178)	7.01 (178)				3.62 (92)				4.25 (108)	2.13 (54)		5.12 (130)		0.55 (14)	0.43 (11)
1440Y													6.42 (163)		0.43 (11)	1.73 (44)

Model	Ratio	NEMA Frame	CE	C	XJ	AK	BD	AJ	BF	Z	BB	Min. ID	ZA	Wt. (lbs.)
RNYJ-1420Y	40~60	42C	15.1 (383)	13.3 (338)	1.78 (45)	3.00 (76.2)	4.33 (110)	3.75 (95.3)	0.28 (7)	0.47 (12)		2.44 (62)		35 (16)
RNYJ-1420Y		48C	15.5 (393)		2.16 (55)									36 (16)
RNYJ-1420Y		56C	15.9 (405)		2.63 (67)									38 (17)
RNYJ-1420Y		143TC	16.3 (414)		13.7 (347)									4.500 (114.3)
RNYJ-1420Y	5~30	143TC~145TC	15.4 (392)	12.8 (325)	2.63 (67)							4.21 (107)		37 (17)
RNYJ-1430Y	80~120	56C	15.5 (393)	12.8 (326)										
RNYJ-1430Y	150~240													
RNYJ-1440Y	300~1440	48C	15.9 (403)	13.7 (348)	2.16 (55)	3.00 (76.2)	4.33 (110)	3.750 (95.3)	0.28 (7)			2.44 (62)		31 (14)
RNYJ-1440Y	300~720	56C	16.3 (413)		2.56 (65)	4.500 (114.3)	6.69 (170)	5.875 (149.2)	0.43 (11)			3.15 (80)		32 (15)

Model	XU	XU Tolerance	XV
RNYJ-1420Y	0.625	+0/ -0.0004	0.98
RNYJ-1430Y			
RNYJ-1440Y	0.5		

C-Face Dimensions

Frame Size 1500 RNYJ-1520/30/31/40Y

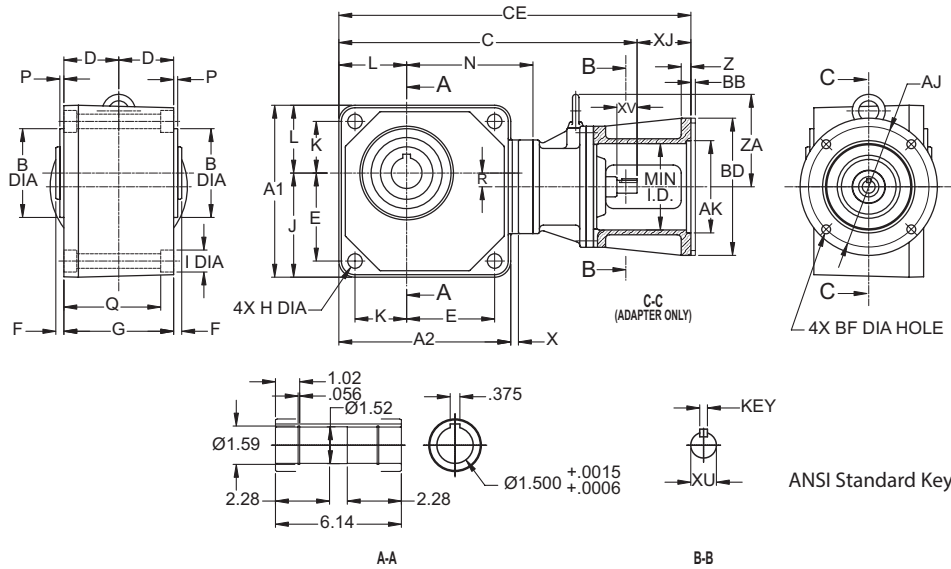

All dimensions are in inches.

Model	A1	A2	B min	B max	D	E	F	G	H	J	K	L	N	P	R	X
1520Y	7.01 (178)	6.89 (175)				3.15 (80)			0.55 (14)	3.7 (94)	2.76 (70)		7.01 (178)		1.1 (28)	2.68 (68)
1530/31Y	8.39 (213)	8.39 (213)	4.32930 (109.965)	4.3307 (110.000)	2.68 (68)	4.29 (109)	0.39 (10)	5.35 (136)	0.71 (18)	5.08 (129)	2.52 (64)	3.31 (84)	6.18 (157)	0.2 (5)	0.67 (17)	0.37 (10)
1540Y													7.76 (197)		0.55 (14)	2.13 (54)

Model	Ratio	NEMA Frame	CE	C	XJ	AK	BD	AJ	BF	Z	BB	Min. ID	ZA	Wt. (lbs.)
RNYJ-1520Y	5~60	56C~145TC	19.2 (488)	16.6 (421)	2.63 (67)	4.500 (114.3)	6.69 (170)	5.875 (149.2)	0.43 (11)			4.21 (107)		67 (30)
RNYJ-1530Y	80~120	42C	16.1 (408)	14.3 (363)	1.78 (45)	3.00 (76.2)	4.33 (110)	3.75 (95.3)	0.28 (7)	0.47 (12)	-	2.44 (62)	-	51 (23)
RNYJ-1530Y		48C	16.4 (418)		2.16 (55)		4.33 (110)		0.28 (7)			53 (24)		
RNYJ-1530Y		56C	16.9 (430)		2.63 (67)	4.500 (114.3)	5.875 (149.2)	0.43 (11)	54 (25)					
RNYJ-1530Y	150~240	42C	17.2 (437)	14.6 (370)	1.78 (45)	3.00 (76.2)	4.33 (110)	3.75 (95.3)	0.28 (7)	0.47 (12)	-	4.21 (107)	-	52 (24)
RNYJ-1530Y			16.3 (415)									2.44 (62)		52 (24)
RNYJ-1531Y	40~80	56C~145TC	17.9 (455)	15.3 (388)	2.63 (67)	4.500 (114.3)	6.69 (170)	5.875 (149.2)	0.43 (11)	0.47 (12)	-	4.21 (107)	-	64 (29)
RNYJ-1540Y	300~1440		18.6 (474)	16.0 (407)										57 (26)

Model	XU	XU Tolerance	XV
RNYJ-1520Y	0.75	+0/ -0.0005	1.38
RNYJ-1530Y	0.625	+0/ -0.0004	0.98
RNYJ-1531Y	0.75	+0/ -0.0005	
RNYJ-1540Y	0.625	+0/ -0.0004	

C-Face Dimensions

Frame Size 1600
RNYJ-1640Y

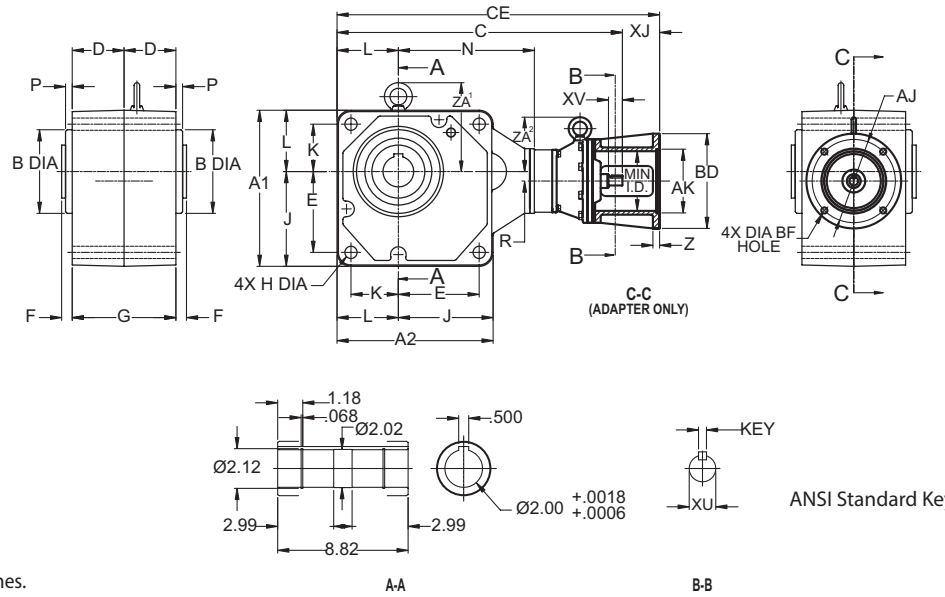

All dimensions are in inches.

Speed Reducers

Dimensions

Model	A1	A2	B min	B max	D	E	F	G	H	J	K	L	N	P	R	ZA ¹
1640Y	11.02 (280)	11.02 (280)	5.9039 (149.960)	5.9055 (150)	3.66 (93)	5.71 (145)	0.75 (19)	7.32 (186)	0.87 (22)	6.69 (170)	3.35 (85)	4.33 (110)	9.29 (236)	0.47 (12)	0.67 (17)	6.3 (160)

Model	Ratio	NEMA Frame	CE	C	XJ	AK	BD	AJ	BF	Z	Min. ID	ZA ²	Wt. (lbs.)
RNYJ-1640Y	300~720	56C ~ 145TC	21.1 (535)	18.4 (468)	2.63 (67)	4.500 (114.3)	6.69 (170)	5.875 (149.2)	0.43 (11)	0.47 (12)	4.21 (107)	6.97 (177)	137 (62)
RNYJ-1640Y	900~1440		21.3 (542)	18.7 (475)									138 (62)

Model	XU	XU Tolerance	XV
RNYJ-1640Y	0.625	+0/ -0.0004	0.98

Page intentionally left blank.

Speed
Reducers

Selection
Tables

3

Gearmotors

Hollow Shaft Type



Hyponic®

How to
Select

How to Select a Gearmotor

Step 1: Collect data about your application

Before starting you need to know the:

- Application (e.g. Conveyor, Mixer, etc.)
- Hours of Operation per day
- Motor Horsepower (HP) and Speed (RPM)
- Desired Output Speed
- Mounting Position and Style
- Overhung or Thrust Loads
- Bore Dimensions, inch or metric
- Electrical Specifications
- Ambient Conditions

Step 2: Select a Frame Size

2A: Find the Load Classification of your application in the AGMA Load Classification Tables on pages 3.6 and 3.7. If the Hyponic® Gearmotor will be used in a frequent starts and stops application and the motor will be operated across the line, please refer to Method B on page 3.6.

2B: Go to the Gearmotor Selection Table that corresponds to the desired Motor HP. Find the Output Speed closest to the desired output speed.

2C: For AGMA Load Classification Method A or C on page 3.6, locate the Service Class in the Gearmotor Selection Tables (starting on page 3.10) for your application and select the Frame Size SELECTION that matches the HP, Output Speed, and Service Class. For Method B, select the Frame Size SELECTION that matches HP, Output speed and Service Factor (NOTE: Service Factor should be equal or exceed to calculated Service Factor on Method B).

Step 3: Verify Dimensions

Use the Dimensions information on pages 3.36–3.46 to verify that the selected Frame Size is appropriate.

Step 4: Choose Options

The following options may apply:

- Solid Shaft
- Mounting Feet
- Output Flange
- Torque Arm Assembly
- Washdown

Refer to Section 4 of this catalog for dimension drawings of selected popular options.

For additional options, please visit our configurator at:

www.sumitomodrive.com/configurator

Step 5: Configure a Model Number

Go to page 3.4 thru 3.5 to configure a model number.

Note: You will use the information you gather from the procedure on this page to configure a model number.

Hyponic®

How to
Select



Selection Tables

Dimensions:		Frame Size	Page	Frame Size	Page
		1100	2.xx	1400	2.xx
		1200	2.xx	1500	2.xx
		1300	2.xx	1600	2.xx

Frequency	Hz	50	60
Number of Poles	P	4	
Input Speed	RPM	1450	1750

2 HP
1.5 kW

- Motor HP
- Output Speed
- Service Class (Method A or C)
- SELECTION
- Service Factor (Method B)

50Hz						60Hz						Selection					
Output Speed (RPM)	Output Torque		Service Factor		Solid Shaft Overhung Load		Output Speed (RPM)	Output Torque		Service Factor		Solid Shaft Overhung Load		Motor Power Code	Base Frame Size	Ratio	Max RPM
	in-lbs	(N·m)	SF	AGMA Class	lbs	(N)		in-lbs	(N·m)	SF	AGMA Class	lbs	(N)				
290	372	(42.0)	1.03	I	486	(2160)	350	306	(34.6)	1.03	I	463	(2060)	2	1420	5	
			1.49	II	706	(3140)				1.50	II	661	(2940)	2	1520	5	
207	520	(58.8)	1.03	I	551	(2450)	250	429	(48.4)	1.03	I	517	(2300)	2	1420	7	
			1.49	II	794	(3530)				1.50	II	749	(3330)	2	1520	7	
145	743	(84.0)	1.03	I	618	(2750)	175	613	(69.2)	1.03	I	585	(2600)	2	1420	10	
			1.49	II	881	(3920)				1.50	II	839	(3730)	2	1520	10	
121	892	(101)	1.03	I	638	(2840)	146	735	(83.0)	1.03	I	618	(2750)	2	1420	12	
			1.49	II	926	(4120)				1.50	II	892	(3970)	2	1520	12	
96.7	1110	(126)	1.03	I	695	(3090)	117	919	(104)	1.03	I	661	(2940)	2	1420	15	
			1.49	II	991	(4410)				1.50	II	949	(4220)	2	1520	15	
72.5	1490	(168)	1.03	I	749	(3330)	87.5	1230	(138)	1.03	I	717	(3190)	2	1420	20	
			1.49	II	1080	(4810)				1.50	II	1040	(4610)	2	1520	20	
58.0	1860	(210)	1.03	I	794	(3530)	70.0	1530	(173)	1.03	I	760	(3380)	2	1420	25	
			1.49	II	1150	(5100)				1.50	II	1100	(4900)	2	1520	25	
48.3	2230	(252)	1.03	I	839	(3730)	58.3	1840	(208)	1.03	I	805	(3580)	2	1420	30	
			1.49	II	1200	(5340)				1.50	II	1160	(5150)	2	1520	30	

Hyponic®
How to Select

For special circumstances affecting Frame Size selection such as:

- Overhung Load
- Shock Loading

See Technical Information section, page 5.8

If Overhung Load is present, it must be checked against the capacity of the selection.



Configure a Model Number

Required to be added at end of model number when ordering:

- Motor specifications (230/460 VAC 60 Hz is supplied, unless otherwise specified)
- Keyed Hollow Bore or Output Shaft or Shrink Disc diameter must be specified (refer to pages 4.9 to 4.10 for diameters)
- Optional Industry Package SSC code, refer to page 4.11
- Optional conduit box positions available, please reference pages 5.16 for details.

Output Shaft Orientation

Type	Code
Universal Direction (Maintenance Free)	N

Mounting Style

Type	Code
Shaft Mount (Hollow Shaft)	Y
Flange (Solid Shaft)	F
Foot (Solid Shaft)	H

Input Connection

Input Connection	Code
Integral Motor	M
C-Face Adaptor	JM
Hollow Input Shaft	XM

Frame Size

1120	1522
1220	1530
1230	1531
1320	1540
1330	1630
1340	1631
1420	1632
1430	1633
1440	1634
1520	1640
1521	

Output Shaft Direction (for solid shaft option only)

Direction (when viewed from motor end)	Code
Projects to Left Side	L
Projects to Right Side	R
Projects to Both Sides	T

*For dimensions refer to page 4.2 to 4.5

Modification

Type	Code
Unit built with special modifications including, Shrink Disc	S
No special modifications applied	

Motor Power (applies only to 1750 RPM)

HP	kW	Code
1/8	(0.1)	01
1/4	(0.2)	02
1/3	(0.25)	03
1/2	(0.4)	05
3/4	(0.55)	08
1	(0.75)	1
1.5	(1.1)	1H
2	(1.5)	2
3	(2.2)	3
5	(3.7)	5
7.5	(5.5)	8
10	(7.5)	10
15	(11)	15

AGMA Class

Class	Code
I	A
II	B
III	C

Motor Specification

Specification	Code
AF Motor (Inverter Duty 1/8 HP to 3/4 HP)	AV
Inverter Ready Motor Premium Efficiency (1+HP), IE3	EP
*DC Motor	DV
*Low Backlash	LB
*Servo Motor	SV

*For Technical Information please contact customer service.

Note: When there are multiple suffices, sequence them alphabetically. Ex.: EPLB

Brake

	Code
With Brake	B
No Brake	-

R N Y M 1 - 1320 Y A - EP - - 20

Hyponic product code (always "R")

Output shaft orientation

Mounting style

Input connection

Motor Power Code (1750 rpm)

Frame size

Modification (Special feature)

Shaft specification

AGMA class

Brake

Ratio

Optional Specification (as required)

Motor Specification

Output shaft direction (shafted model only)

Hyponic®

Nomenclature

Nomenclature

Shaft Specifications

Input Shaft	Output Shaft		Code
	Hollow	Solid	
Metric (JIS)	Key (Inch)	Key (Inch)	
Metric (DIN)	-	Key (mm)	E
Inch	Key (Inch)	Key (Inch)	Y

Optional Specifications (as required)

Specification	Code
Hollow Bore Options	
Extended Flange page 4.5 (for motor clearance)	
Left (viewed from motor end)	F1
Right (viewed from motor end)	G1
Solid Shaft Options pages 4.2-4.3	
Plug-in Shaft	X1
Plug-in Shaft with Bolt-on Feet page 4.4	
Bottom	J1
Opposite from Motor	S1
Top	M1
Plug-in Shaft with Extended Flange page 4.5 (for motor clearance)	
Left (viewed from motor end)	P1
Right (viewed from motor end)	Q1

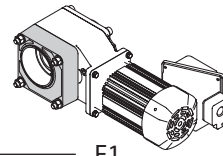

F1

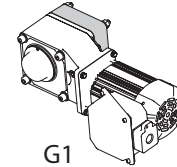

G1

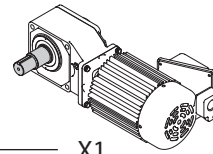

X1

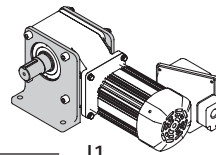

J1

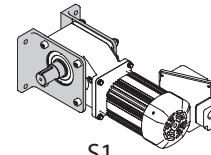

S1

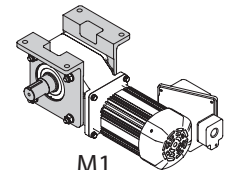

M1

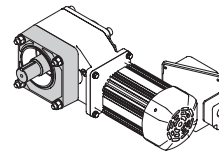

P1

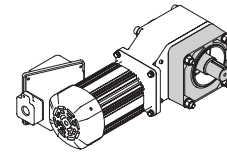

Q1

Nominal Total Ratio

5	20	60	200	600
7	25	80	240	720
10	30	100	300	900
12	40	120	360	1200
15	50	150	480	1440

Nomenclature Example:

RNYM1-1320YA-EP-20

R – Hyponic®

N – Universal Mount

Y – Shaft Mounted (hollow shaft)

M – Integral Motor

1 – HP, 1750 RPM

1320 – Frame Size

Y – Inch Shaft Specification

A – AGMA Class I

EP – Three Phase Motor Premium Efficiency

20 – Ratio

Hyponic®

Nomenclature

Step 2A - AGMA Load Classifications: Gearmotors

Select Service factor by Method A or B or C:

Method A - Gearmotor Classification by LOAD			
DURATION OF SERVICE	GEARMOTOR CLASS		
	UNIFORM LOAD	MODERATE SHOCK LOAD	HEAVY SHOCK LOAD
Intermittent 3 hours per day	Class I	Class I	Class II
Up to 10 hours per day	Class I	Class II	Class III
24 hours per day	Class II	Class III	—

Class I = Steady loads not exceeding normal motor rating, 8 to 10 hours a day. Moderate shock loads where service is intermittent (AGMA Service Factor: 1.0).
Class II = Steady loads not exceeding normal motor rating and 24 hours a day service. Moderate shock loads for 8 hours a day (AGMA Service Factor: 1.4).
Class III = Moderate shock loads for 24 hours a day or heavy shock loads for 8 hours a day (AGMA Service Factor: 2.0)
Note: Selections without an AGMA Class designation are torque based selections generally used for intermittent service.

Method B - Recommended Service Factors for Frequent Start-Stop Applications for EP Motors						
For frequent start-stop applications with motor operated across the line, use the table below to determine the recommended service factor, and check the Motor Thermal Rating (Table 4.30) in Section 4. For determination of moment of inertia, see page 4.30.						
Number of start-stops (Times/hour)	~ 10 hours/day			~24 hours/day		
	I	II	III	I	II	III
~10	1.00	1.15	1.50	1.20	1.30	1.65
~200	1.10	1.35	1.65	1.30	1.50	1.85
~500	1.15	1.50	1.80	1.40	1.65	2.00
1	1.00	1.15	1.50	1.20	1.30	1.65
~3	1.00	1.25	1.60	1.20	1.40	1.70
~10	1.00	1.35	1.70	1.20	1.50	1.80
~60	1.00	1.45	1.75	1.25	1.65	2.00

Three-phase motors from 1/8 HP to 3/4 (0.1 to 0.55 kW)
 Premium Efficiency three-phase motors 1HP to 75 HP (0.75 to 55 kW), high-efficiency three-phase motors from 1/4 HP to 1/2 HP (0.2 to 0.4 kW)

Inertia (Moment of Inertia WR^2) Ratio = $\frac{\text{Total Moment of Inertia } (WR^2) \text{ as seen from motor shaft}}{\text{Moment of Inertia } (WR^2) \text{ of motor}}$

I = Allowable Inertia (WR^2) Ratio: Inertia Ratio ≤ 0.3
 II = Allowable Inertia (WR^2) Ratio: $0.3 < \text{Inertia Ratio} \leq 3.0$
 III = Allowable Inertia (WR^2) Ratio: $3.0 < \text{Inertia Ratio} \leq 10.0$

Note: 1. The number of start-stops includes brake or clutch operation times.
 2. Consult us when starting under loaded conditions such as torque or radial load.
 3. Consult us when start-stop frequency or Moment of Inertia Ratio exceeds that shown above.

Specification Inspection Items
 - if there is a shoulder bolt or knockpin used on mating surface of reducer
 - change in case material
 - if using high frequency brake

Hyponic®
AGMA Tables

Method C - Load Classification by INDUSTRY											
Application	Class		Application	Class		Application	Class		Application	Class	
	Up to 10 Hr. Per Day	24 Hr. Per Day		Up to 10 Hr. Per Day	24 Hr. Per Day		Up to 10 Hr. Per Day	24 Hr. Per Day		Up to 10 Hr. Per Day	24 Hr. Per Day
Brewing & Distilling	I	II	Lumber Industry	Consult Factory		Oil Well Pumping	Consult Factory		Sheeter	II	II
Bottling Machinery	I	II	Barkers–Spindle Feed	Consult Factory		Paraffin Filter Press	II	II	Tire Building Machines	Consult Factory	
Brew Kettles, Cont. Duty	–	II	Barkers–Main Drive	Consult Factory		Rotary Kilns	II	II	Tire, Tube Press		
Can Filling Machines	I	II	Carriage Drive	Consult Factory					Openers	Consult Factory	
Cookers–Cont. Duty	–	II	Conveyors			Paper Mills			Tubers & Stainers	II	II
Mash Tubs–Cont. Duty	–	II	Burner	II	III	Agitators (Mixers)	II	II			
Scale Hoppers–			Main or Heavy Duty	II	III	Barker–Auxiliaries–			Sewage Disposal		
Frequent Starts	II	II	Main Log	III	III	Hyd.	Consult Factory		Aerators	Consult Factory	
			Re-Saw Merry-Go-Round	III	III	Barker, Mechanical	Consult Factory		Bar Screens	I	II
Clay Working Industry			Slab	III	III	Barking Drum	Consult Factory		Chemical Feeders	I	II
Brick Press	III	III	Transfer	II	III	Beater & Pulper	–	II	Collectors	I	II
Briquette Machines	III	III	Chains–Floor	II	III	Bleacher	–	II	Dewatering Screens	II	II
Clay Working Machinery	II	II	Chains–Green	II	III	Calenders	–	II	Grit Collectors	I	II
Pug Mills	II	II	Cut-Off Saws–Chain	II	III	Calenders–Super	–	II	Scum Breakers	II	II
			Cut-Off Saws–Drag	II	III	Converting Mach.–			Slow or Rapid Mixers	II	II
Distilling (See Brewing)			Debarking Drums	Consult Factory		Except Cutters–Platers	–	II	Sludge Collectors	I	II
			Feeds–Edger	II	III	Conveyors	–	II	Thickeners	II	II
Dredges			Feeds–Gang	II	III	Couch	–	II	Vacuum Filters	II	II
Cable Reels	II	–	Feeds–Trimmer	II	III	Cutters, Platers	–	III			
Conveyors	II	II	Log Deck	III	III	Cylinders	–	II	Textile Industry		
Cutter Head Drives	III	III	Log Hauls–Incline,			Dryers	–	II	Batchers	II	II
Jig Drives	III	III	Well Type	III	III	Felt Stretchers	–	II	Calenders	II	II
Maneuvering Winches	II	–	Log Turning Devices	III	III	Felt Whippers	–	III	Card Machines	II	II
Pumps	II	II	Planer Feed	II	III	Jordans	–	II	Cloth Finishing Machines		
Screen Drives	III	III	Transfers–Chain	II	III	Log Haul	–	III	(Calenders, Dryers, Pads,		
Stackers	II	II	Transfers–Craneway	II	III	Presses	–	II	Tenters, Washers)	II	II
Utility Winches	II	–	Tray Drives	II	III	Pulp Machine Reels	–	II	Dry Cans	II	II
						Stock Chests	–	II	Dyeing Machinery	II	II
Food Industry			Oil Industry			Suction Rolls	–	II	Knitting Machinery	Consult Factory	
Beet Slicers	I	II	Chillers	II	II	Washers & Thickeners	–	II	Looms, Mangles, Nappers	II	II
Bottlings, Can	I	II				Winders	–	II	Range Drives	Consult Factory	
Filling Mach.	I	II							Soapers, Spinners	II	II
Cereal Cookers	I	II				Rubber Industry			Tenter Frames	II	II
Dough Mixers	II	II				Mixer	III	III	Winders	II	II
Meat Grinders	II	II				Rubber Calender	II	II	Yarn Preparatory Machinery		
						Rubber Mill (2 or more)	II	II	(Cards, Spinners, Slashers)	II	II

...table continued on next page.

Method C continued - Load Classification by APPLICATION											
Application	Class		Application	Class		Application	Class		Application	Class	
	Up to 10 Hr. Per Day	24 Hr. Per Day		Up to 10 Hr. Per Day	24 Hr. Per Day		Up to 10 Hr. Per Day	24 Hr. Per Day		Up to 10 Hr. Per Day	24 Hr. Per Day
Agitators			Jig Drives	III	III	Tray Drives	II	III	Pullers		
Pure Liquids	I	II	Maneuvering Winches	II	-	Veneer Lathe Drives	Consult Factory		Barge Haul	III	III
Liquids and Solids	II	II	Pumps	II	II	Machine Tools			Pumps		
Liquids - Variable Density	II	II	Screen Drive	III	III	Bending Roll	II	II	Centrifugal	I	II
Semi-liquids - Variable Density	II	II	Stackers	II	II	Notching Press - Belt Driven	Consult Factory		Proportioning	II	II
			Utility Winches	II	-	Plate Planer	III	III	Reciprocating		
Blowers			Elevators			Punch Press - Gear Driven	III	III	Single Acting		
Centrifugal	I	II	Bucket - Uniform Load	I	II	Other Machine Tools			3 or more		
Lobe	II	II	Bucket - Heavy Load	I	II	Main Drives	II	II	Cylinders	II	II
Vane	I	II	Bucket - Continuous	I	II	Auxiliary Drives	I	II	Double Acting		
Brewing and Distilling			Centrifugal Discharge	I	II	Metal Mills			2 or more		
Bottling Machinery	I	II	Escalators	I	II	Bridle Roll Drives	III	III	Cylinders	II	II
Brew Kettles - Continuous Duty	-	II	Freight	I	II	Draw Bench - Carriage	III	III	Single Acting		
Cookers - Continuous Duty	-	II	Gravity Discharge	I	II	Draw Bench - Main Drive	III	III	1 or 2 Cylinders	Consult Factory	
Mash Tubs - Continuous Duty	-	II	Man Lifts	Consult Factory		Forming Machines	III	III	Double Acting		
Scale Hopper	II	II	Passenger	III	-	Pinch Dryer & Scrubber Rolls, Reversing	Consult Factory		Single Cylinder	Consult Factory	
Frequent Starts	II	II	Service - Hand Lift	III	-	Slitters	II	II	Rotary - Gear Type - Lobe, Vane	I	II
Can Filling Machines			Fans			Table Conveyors	II	III	Rubber Industry		
Cane Knives			Centrifugal	II	II	Non-Reversing	II	III	Mixer	III	III
Car Dumpers			Cooling Towers	II	II	Reversing	-	III	Rubber Calender	II	II
Car Pullers - Intermittent Duty			Induced Draft	II	II	Wire Drawing & Flattening Machine	II	III	Rubber Mill		
Clarifiers			Forced Draft	Consult Factory		Wire Winding Machine	II	II	(2 or more)	II	II
Classifiers			Induced Draft	II	II	Mills, Rotary Type			Sheeter	II	II
Clay Working Machinery			Large (Mine, etc.)	II	II	Ball	III	III	Tire Building Machines		
Brick Press	III	III	Large Industrial	II	II	Cement Kilns	II	II	Tire & Tube Press		
Briquette Machine	III	III	Light (Small Diameter)	I	II	Dryers & Coolers	II	II	Openers		
Clay Working Machinery	II	II	Feeders			Kilns	II	II	Subers & Strainers	II	II
Pug Mill	II	II	Apron	II	II	Pebble	III	III	Sewage Disposal Equipment		
Compressors			Belt	I	II	Rod	III	III	Aerators	Consult Factory	
Centrifugal	I	II	Disc	I	II	Tumbling Barrels	III	III	Bar Screens	I	II
Lobe	II	II	Reciprocating	III	III	Mixers			Chemical Feeders	I	II
Reciprocating	II	II	Screw	III	III	Concrete Mixers, Continuous	II	II	Collectors, Circuline or Straightline	I	II
Multi-Cylinder	II	II	Food Industry			Concrete Mixers, Intermittent	I	-	Dewatering Screens	II	II
Single Cylinder	III	III	Beet Slicer	I	II	Constant Density	I	II	Grit Collectors	I	II
Conveyors - Uniformly Loaded or Fed			Cereal Cooker	I	II	Variable Density	II	II	Scum Breakers	II	II
Apron	I	II	Dough Mixer	II	II	Oil Industry			Slow or Rapid Mixers	II	II
Assembly	I	II	Meat Grinders	II	II	Chillers	II	II	Sludge Collectors	I	II
Belt	I	II	Generators - (Not Welding)			Oil Well Pumping	Consult Factory		Thickeners	II	II
Bucket	I	II	Hammer Mills	III	III	Paraffin Filter Press	II	II	Vacuum Filters	II	II
Chain	I	II	Laundry Washers	II	II	Rotary Kilns	II	II	Screeners		
Flight	I	II	Reversing	II	II	Paper Mills			Air Washing	I	II
Oven	I	II	Laundry Tumblers	II	II	Aerators	Consult Factory		Rotary - Stone or Gravel	II	II
Screw	I	II	Line Shafts			Agitators (Mixers)	II	II	Traveling Water Intake	I	II
Conveyors - Heavy Duty Not Uniformly Fed			Heavy Shock Load	III	III	Barker Auxiliaries, Hydraulic	Consult Factory		Slab Pushers		
Apron	II	II	Moderate	II	II	Barking Drum	Consult Factory		Steering Gear	II	II
Assembly	II	II	Shock Load	II	II	Beater & Pulper	Consult Factory		Stokers	I	II
Belt	II	II	Uniform Load	I	II	Bleacher	-	II	Textile Industry		
Bucket	II	II	Lumber Industry			Calenders	-	II	Batchers	II	II
Chain	II	II	Barkers - Spindle Feed	Consult Factory		Calenders - Super	-	II	Calenders	II	II
Flight	II	II	Barkers - Main Drive	Consult Factory		Converting Machines, except Cutters, Platers	-	II	Card Machines	II	II
Live Roll (Package)	I	II	Carriage Drive	Consult Factory		Conveyors	-	II	Cloth Finishing Machines		
Oven	II	II	Conveyors - Burner	II	III	Conveyors, Log	-	III	(Washers, Pads, Tenters)		
Reciprocating	III	III	Conveyors - Main or Heavy Duty	II	III	Cutters, Platers	-	II	(Dryers, Calenders, etc.)	II	II
Screw	II	II	Conveyors - Main Log	III	III	Cylinders	-	II	Dry Cans	II	II
Shaker	III	III	Conveyors - Merry-Go-Round	II	III	Dryers	-	II	Dryers	II	II
Cranes and Hoists			Conveyors - Slab	III	III	Dyeing Machinery	-	II	Dyeing Machinery	II	II
Main Hoists	III	III	Conveyors - Transfer	II	II	Knitting Machines (Looms, etc.)	-	II	Knitting Machines	II	II
Heavy Duty	III	III	Conveyors - Waste	II	II	Looms	-	II	(Looms, etc.)	Consult Factory	
Medium Duty	II	II	Chains - Floor	II	III	Mangles	-	II	Nappers	II	II
Reversing	II	II	Chains - Green	II	III	Nappers	-	II	Pads	II	II
Skip Hoists	II	II	Cut-Off Saws - Chain	II	III	Range Drives	-	II	Slashers	Consult Factory	
Trolley Drive	II	II	Cut-Off Saws - Drag	II	III	Slashers	-	III	Soapers	II	II
Bridge Drive	II	II	Debarking Drums	II	III	Spinnners	-	II	Teneter Frames	II	II
Crushers			Feeds - Edger	III	III	Washers	-	II	Washers	II	II
Ore	III	III	Feeds - Gang	III	III	Winders (Other than Batcher)	-	II	Winders (Other than Batcher)	II	II
Stone	III	III	Feeds - Trimmer	II	III	Yarn Preparatory Machines (Cards, Spinnners, Slashers, etc.)	-	II	Yarn Preparatory Machines (Cards, Spinnners, Slashers, etc.)	II	II
Dredges			Log Deck	III	III	Windlass					
Cable Reels	II	-	Log Hauls - Incline Well Type	III	III						
Conveyors	II	II	Log Turning Devices	III	III						
Cutter Head Drives	III	III	Planer Feed	II	III						
			Planer Tilting Hoists	II	III						
			Rolls - Live - Off Brg. - Roll Cases	III	III						
			Sorting Table	II	III						
			Tipple Hoist	II	III						
			Transfers - Chain	II	III						
			Transfers - Craneway	II	III						
						Printing Presses	I	II			

Hyponic®
AGMA Tables

Constant Torque Speed Ranges: Gearmotors

Table 2.8 Turn Down Ratio (CTSR) for Integral Motors in CONSTANT TORQUE Applications Powered by Inverters.

Fractional HP Motors - 60 Hz				
Motor Power (4 - Pole)	Standard Motor		AF Motor	
	W/o Brake	With Brake	With Brake	
1/8 HP (0.1 kW)	2:1	2:1	10:1	10:1
1/4 HP (0.2 kW)	2:1	2:1	10:1	10:1
1/3 HP (0.25 kW)	2:1	2:1	10:1	10:1
1/2 HP (0.4 kW)	2:1	2:1	10:1	10:1
3/4 HP (0.55 kW)	2:1	2:1	10:1	10:1

Premium Efficiency Integral HP Motors - 60 Hz			
Motor Power (4 - Pole)	Standard Motor		Oversized Motor (SSC YA01)
	W/o Brake	With Brake	With Brake
1 HP (0.75 kW)	10:1	10:1	
1.5 HP (1.1 kW)	10:1	5:1	10:1
2 HP (1.5 kW)	10:1	4:1	10:1
3 HP (2.2 kW)	10:1	4:1	10:1
5 HP (3.7 kW)	10:1	4:1	10:1
7.5 HP (5.5 kW)	10:1	4:1	10:1
10 HP (7.5 kW)	10:1	6:1	10:1
15 HP (11 kW)	10:1	6:1	10:1

For motor selection considerations for inverter (VFD) operation please refer to pages 5.27 and 5.28.

Hyponic

CTSR Table

Page intentionally left blank.

Selection Tables

Three-Phase

1/8 HP 0.1 kW	Frequency	50 Hz	60 Hz
	Input Speed	1450 RPM	1750 RPM
	Number of Poles	4	

<i>Dimensions:</i>	Frame Size	Page	Frame Size	Page
	1100	3.36	1400	3.40
	1200	3.37	1500	3.42
	1300	3.38	1600	3.44

50Hz				60Hz				Selection									
Output Speed (RPM)	Output Torque		Service Factor ^[1]		Solid Shaft Overhung Load		Output Speed (RPM)	Output Torque		Service Factor ^[1]		Base		Max Hz ^[2]			
	in-lbs	(N·m)	SF	AGMA Class	lbs	(N)		in-lbs	(N·m)	SF	AGMA Class	lbs	(N)		Motor Power Code	Frame Size	Ratio
290	25	(2.80)	2.00	III	143	(637)	350	19	(2.16)	2.14	III	132	(588)	01	1120	5	120
207	35	(3.92)	2.00	III	154	(686)	250	27	(3.03)	2.14	III	143	(637)	01	1120	7	120
145	50	(5.60)	2.00	III	176	(785)	175	38	(4.33)	2.14	III	165	(735)	01	1120	10	120
121	60	(6.72)	2.00	III	187	(834)	146	46	(5.19)	2.14	III	176	(785)	01	1120	12	120
96.7	74	(8.40)	2.00	III	198	(883)	117	57	(6.49)	2.14	III	187	(834)	01	1120	15	120
72.5	99	(11.2)	2.00	III	220	(981)	87.5	77	(8.65)	2.14	III	209	(932)	01	1120	20	120
58.0	124	(14.0)	2.00	III	232	(1030)	70.0	96	(10.8)	2.14	III	220	(980)	01	1120	25	120
48.3	149	(16.8)	2.00	III	243	(1080)	58.3	115	(13.0)	2.14	III	232	(1030)	01	1120	30	120
36.3	198	(22.4)	1.00	I	265	(1180)	43.8	153	(17.3)	1.07	I	254	(1130)	01	1120	40	120
			2.00	III	364	(1620)				2.14	III	353	(1570)	01	1220	40	120
29.0	248	(28.0)	1.00	I	286	(1270)	35.0	191	(21.6)	1.07	I	277	(1230)	01	1120	50	120
			2.00	III	387	(1720)				2.14	III	375	(1670)	01	1220	50	120
24.2	297	(33.6)	1.00	I	297	(1320)	29.2	230	(26.0)	1.07	I	286	(1270)	01	1120	60	120
			2.00	III	398	(1770)				2.14	III	387	(1720)	01	1220	60	120
18.1	396	(44.8)	1.00	I	398	(1770)	21.9	306	(34.6)	1.07	I	398	(1770)	01	1230	80	120
			2.00	III	661	(2940)				2.14	III	661	(2940)	01	1330	80	120
14.5	495	(56.0)	1.00	I	407	(1810)	17.5	383	(43.3)	1.07	I	398	(1770)	01	1230	100	120
			2.00	III	695	(3090)				2.14	III	683	(3040)	01	1330	100	120
12.1	595	(67.2)	1.00	I	407	(1810)	14.6	459	(51.9)	1.07	I	407	(1810)	01	1230	120	120
			2.00	III	695	(3090)				2.14	III	695	(3090)	01	1330	120	120
9.67	743	(84.0)	1.00	I	407	(1810)	11.7	574	(64.9)	1.07	I	407	(1810)	01	1230	150	120
			2.00	III	695	(3090)				2.14	III	695	(3090)	01	1330	150	120
7.25	868	(98.1)	*	-	407	(1810)	8.75	766	(86.5)	1.07	I	407	(1810)	01	1230	200	120
	991	(112)	1.74	II	695	(3090)				2.14	III	695	(3090)	01	1330	200	120
6.04	868	(98.1)	*	-	407	(1810)	7.29	868	(98.1)	*	-	407	(1810)	01	1230	240	120
	1190	(134)	1.45	II	695	(3090)				1.88	II	695	(3090)	01	1330	240	120
4.83	1490	(168)	1.00	I	695	(3090)	5.83	1150	(130)	1.07	I	695	(3090)	01	1340	300	120
			2.00	III	980	(4360)				2.14	III	980	(4360)	01	1440	300	120
4.03	1780	(202)	1.00	I	695	(3090)	4.86	1380	(156)	1.07	I	695	(3090)	01	1340	360	120
			2.00	III	980	(4360)				2.14	III	980	(4360)	01	1440	360	120

Note: [1] Selections with service factor marked with an asterisk (*) should be limited to the identified output torque.

[2] Maximum allowable input speed is 3600rpm unless otherwise noted.

Variable Frequency Drive (VFD) notes (see page 3.8 for Constant Torque Speed Ranges)

Selection Tables

Three-Phase

<i>Dimensions:</i>	Frame Size	Page	Frame Size	Page
	1100	3.36	1400	3.40
	1200	3.37	1500	3.42
	1300	3.38	1600	3.44

Frequency	50 Hz	60 Hz	1/8 HP 0.1 kW
Input Speed	1450 RPM	1750 RPM	
Number of Poles	4		

50Hz					60Hz					Selection							
Output Speed (RPM)	Output Torque		Service Factor ^[1]		Solid Shaft Overhung Load		Output Speed (RPM)	Output Torque		Service Factor ^[1]		Solid Shaft Overhung Load		Motor Power Code	Base		Max Hz ^[2]
	in-lbs	(N·m)	SF	AGMA Class	lbs	(N)		in-lbs	(N·m)	SF	AGMA Class	lbs	(N)		Frame Size	Ratio	
3.02	1840	(207)	*	-	695	(3090)	3.65	1840	(207)	*	-	695	(3090)	01	1340	480	120
	2380	(269)	1.54	II	980	(4360)		2.00	III	980	(4360)	01	1440	480	120		
2.42	1840	(207)	*	-	695	(3090)	2.92	1840	(207)	*	-	695	(3090)	01	1340	600	120
	2970	(336)	1.24	I	980	(4360)		1.60	II	980	(4360)	01	1440	600	120		
2.01	1840	(207)	*	-	695	(3090)	2.43	1840	(207)	*	-	695	(3090)	01	1340	720	120
	3570	(403)	1.03	I	980	(4360)		1.33	I	980	(4360)	01	1440	720	120		
1.61	1840	(207)	*	-	695	(3090)	1.94	1840	(207)	*	-	695	(3090)	01	1340	900	120
	3670	(415)	*	-	980	(4360)		1.07	I	980	(4360)	01	1440	900	120		
1.21	1840	(207)	*	-	695	(3090)	1.46	1840	(207)	*	-	695	(3090)	01	1340	1200	120
	3670	(415)	*	-	980	(4360)		*	-	980	(4360)	01	1440	1200	120		
1.01	1840	(207)	*	-	695	(3090)	1.22	1840	(207)	*	-	695	(3090)	01	1340	1440	120
	3670	(415)	*	-	980	(4360)		*	-	980	(4360)	01	1440	1440	120		

Hyponic®

Selection Tables

Note: [1] Selections with service factor marked with an asterisk (*) should be limited to the identified output torque.

[2] Maximum allowable input speed is 3600rpm unless otherwise noted.

Variable Frequency Drive (VFD) notes (see page 3.8 for Constant Torque Speed Ranges)

Selection Tables

Three-Phase

1/4 HP 0.2 kW	Frequency	50 Hz	60 Hz
	Input Speed	1450 RPM	1750 RPM
	Number of Poles	4	

<i>Dimensions:</i>	Frame Size	Page	Frame Size	Page
	1100	3.36	1400	3.40
	1200	3.37	1500	3.42
	1300	3.38	1600	3.44

50Hz				60Hz				Selection									
Output Speed (RPM)	Output Torque		Service Factor ^[1]		Solid Shaft Overhung Load		Output Speed (RPM)	Output Torque		Service Factor ^[1]		Base		Max Hz ^[2]			
	in-lbs	(N·m)	SF	AGMA Class	lbs	(N)		in-lbs	(N·m)	SF	AGMA Class	lbs	(N)		Motor Power Code	Frame Size	Ratio
290	50	(5.60)	1.00	I	143	(637)	350	38	(4.33)	1.07	I	132	(588)	02	1120	5	120
			2.00	III	198	(883)				2.14	III	187	(834)	02	1220	5	120
207	69	(7.84)	1.00	I	154	(686)	250	54	(6.06)	1.07	I	143	(637)	02	1120	7	120
			2.00	III	220	(981)				2.14	III	209	(932)	02	1220	7	120
145	99	(11.2)	1.00	I	176	(785)	175	77	(8.65)	1.07	I	165	(735)	02	1120	10	120
			2.00	III	243	(1080)				2.14	III	232	(1030)	02	1220	10	120
121	119	(13.4)	1.00	I	187	(834)	146	92	(10.4)	1.07	I	176	(785)	02	1120	12	120
			2.00	III	254	(1130)				2.14	III	243	(1080)	02	1220	12	120
96.7	149	(16.8)	1.00	I	198	(883)	117	115	(13.0)	1.07	I	187	(834)	02	1120	15	120
			2.00	III	277	(1230)				2.14	III	265	(1180)	02	1220	15	120
72.5	198	(22.4)	1.00	I	220	(981)	87.5	153	(17.3)	1.07	I	209	(932)	02	1120	20	120
			2.00	III	308	(1370)				2.14	III	297	(1320)	02	1220	20	120
58.0	248	(28.0)	1.00	I	232	(1030)	70.0	191	(21.6)	1.07	I	220	(980)	02	1120	25	120
			2.00	III	330	(1470)				2.14	III	308	(1370)	02	1220	25	120
48.3	297	(33.6)	1.00	I	243	(1080)	58.3	230	(26.0)	1.07	I	232	(1030)	02	1120	30	120
			2.00	III	342	(1520)				2.14	III	330	(1470)	02	1220	30	120
36.3	396	(44.8)	1.00	I	364	(1620)	43.8	306	(34.6)	1.07	I	353	(1570)	02	1220	40	120
			2.00	III	596	(2650)				2.14	III	573	(2550)	02	1320	40	120
29.0	495	(56.0)	1.00	I	387	(1720)	35.0	383	(43.3)	1.07	I	375	(1670)	02	1220	50	120
			2.00	III	638	(2840)				2.14	III	618	(2750)	02	1320	50	120
24.2	595	(67.2)	1.00	I	398	(1770)	29.2	459	(51.9)	1.07	I	387	(1720)	02	1220	60	120
			2.00	III	661	(2940)				2.14	III	638	(2840)	02	1320	60	120
18.1	793	(89.6)	1.00	I	661	(2940)	21.9	613	(69.2)	1.07	I	661	(2940)	02	1330	80	120
			2.00	III	969	(4310)				2.14	III	960	(4270)	02	1430	80	120
14.5	991	(112)	1.00	I	695	(3090)	17.5	766	(86.5)	1.07	I	683	(3040)	02	1330	100	120
			2.00	III	980	(4360)				2.14	III	980	(4360)	02	1430	100	120
12.1	1190	(134)	1.00	I	695	(3090)	14.6	919	(104)	1.07	I	695	(3090)	02	1330	120	120
			2.00	III	980	(4360)				2.14	III	980	(4360)	02	1430	120	120
9.67	1490	(168)	1.00	I	695	(3090)	11.7	1150	(130)	1.07	I	695	(3090)	02	1330	150	120
			2.00	III	980	(4360)				2.14	III	980	(4360)	02	1430	150	120

Note: [1] Selections with service factor marked with an asterisk (*) should be limited to the identified output torque.

[2] Maximum allowable input speed is 3600rpm unless otherwise noted.

Variable Frequency Drive (VFD) notes (see page 3.8 for Constant Torque Speed Ranges)

All 1HP+ motors require EP suffix in model number and can be used with a VFD, unless noted.

Hyponic®
Selection Tables

Selection Tables

Three-Phase

Dimensions:	Frame Size	Page	Frame Size	Page
	1100	3.36	1400	3.40
	1200	3.37	1500	3.42
	1300	3.38	1600	3.44

Frequency	50 Hz	60 Hz	1/4 HP 0.2 kW
Input Speed	1450 RPM	1750 RPM	
Number of Poles	4		

50Hz					60Hz					Selection							
Output Speed (RPM)	Output Torque		Service Factor ^[1]		Solid Shaft Overhung Load		Output Speed (RPM)	Output Torque		Service Factor ^[1]		Base		Max Hz ^[2]			
	in-lbs	(N·m)	SF	AGMA Class	lbs	(N)		in-lbs	(N·m)	SF	AGMA Class	lbs	(N)		Motor Power Code	Frame Size	Ratio
7.25	1730	(195)	*	-	695	(3090)	8.75	1530	(173)	1.07	I	695	(3090)	02	1330	200	120
	1980	(224)	1.74	II	980	(4360)		2.14	III	980	(4360)	02	1430	200	120		
6.04	1730	(195)	*	-	695	(3090)	7.29	1730	(195)	*	-	695	(3090)	02	1330	240	120
	2380	(269)	1.45	II	980	(4360)		1.88	II	980	(4360)	02	1430	240	120		
4.83	2970	(336)	1.00	I	980	(4360)	5.83	2300	(260)	1.07	I	980	(4360)	02	1440	300	120
			2.00	III	1400	(6230)				2.14	III	1400	(6230)	02	1540	300	120
4.03	3570	(403)	1.00	I	980	(4360)	4.86	2760	(311)	1.07	I	980	(4360)	02	1440	360	120
			1.93	II	1400	(6230)				2.14	III	1400	(6230)	02	1540	360	120
3.02	3670	(415)	*	-	980	(4360)	3.65	3670	(415)	*	-	980	(4360)	02	1440	480	120
	4760	(537)	1.45	II	1400	(6230)		3680		1.87	II	1400	(6230)	02	1540	480	120
2.42	3670	(415)	*	-	980	(4360)	2.92	3670	(415)	*	-	980	(4360)	02	1440	600	120
	5950	(672)	1.16	I	1400	(6230)		4590	(519)	1.50	II	1400	(6230)	02	1540	600	120
2.01	3670	(415)	*	-	980	(4360)	2.43	3670	(415)	*	-	980	(4360)	02	1440	720	120
	6880	(778)	*	-	1400	(6230)		5510	(623)	1.25	I	1400	(6230)	02	1540	720	120
1.61	3670	(415)	*	-	980	(4360)	1.94	3670	(415)	*	-	980	(4360)	02	1440	900	120
	6880	(778)	*	-	1400	(6230)		6880	(778)	*	-	1400	(6230)	02	1540	900	120
1.21	3670	(415)	*	-	980	(4360)	1.46	3670	(415)	*	-	980	(4360)	02	1440	1200	120
	6880	(778)	*	-	1400	(6230)		6880	(778)	*	-	1400	(6230)	02	1540	1200	120
1.01	3670	(415)	*	-	980	(4360)	1.22	3670	(415)	*	-	980	(4360)	02	1440	1440	120
	6880	(778)	*	-	1400	(6230)		6880	(778)	*	-	1400	(6230)	02	1540	1440	120

Hyponic®

Selection
Tables

Note: [1] Selections with service factor marked with an asterisk (*) should be limited to the identified output torque.

[2] Maximum allowable input speed is 3600rpm unless otherwise noted.

Variable Frequency Drive (VFD) notes (see page 3.8 for Constant Torque Speed Ranges)

All 1HP+ motors require EP suffix in model number and can be used with a VFD, unless noted.

Selection Tables

Three-Phase

1/3 HP 0.25 kW	Frequency	50 Hz	60 Hz
	Input Speed	1450 RPM	1750 RPM
	Number of Poles	4	

<i>Dimensions:</i>	Frame Size	Page	Frame Size	Page
	1100	3.36	1400	3.40
	1200	3.37	1500	3.42
	1300	3.38	1600	3.44

Output Speed (RPM)	50Hz						60Hz						Selection				
	Output Torque		Service Factor ^[1]		Solid Shaft Overhung Load		Output Speed (RPM)	Output Torque		Service Factor ^[1]		Solid Shaft Overhung Load		Base			Max Hz ^[2]
	in-lbs	(N·m)	SF	AGMA Class	lbs	(N)		in-lbs	(N·m)	SF	AGMA Class	lbs	(N)	Motor Power Code	Frame Size	Ratio	
290	62	(7.00)	1.60	II	198	(883)	350	51	(5.77)	1.61	II	187	(834)	03	1220	5	120
207	87	(9.80)	1.60	II	220	(981)	250	72	(8.07)	1.61	II	209	(932)	03	1220	7	120
145	124	(14.0)	1.60	II	243	(1080)	175	102	(11.5)	1.61	II	232	(1030)	03	1220	10	120
121	149	(16.8)	1.60	II	254	(1130)	146	123	(13.8)	1.61	II	243	(1080)	03	1220	12	120
96.7	186	(21.0)	1.60	II	277	(1230)	117	153	(17.3)	1.61	II	265	(1180)	03	1220	15	120
72.5	248	(28.0)	1.60	II	308	(1370)	87.5	204	(23.1)	1.61	II	297	(1320)	03	1220	20	120
58.0	310	(35.0)	1.60	II	330	(1470)	70.0	255	(28.8)	1.61	II	308	(1370)	03	1220	25	120
48.3	372	(42.0)	1.60	II	342	(1520)	58.3	306	(34.6)	1.61	II	330	(1470)	03	1220	30	120
36.3	495	(56.0)	1.60	II	596	(2650)	43.8	408	(46.1)	1.61	II	573	(2550)	03	1320	40	120
29.0	619	(70.0)	1.60	II	638	(2840)	35.0	510	(57.7)	1.61	II	618	(2750)	03	1320	50	120
24.2	743	(84.0)	1.60	II	661	(2940)	29.2	613	(69.2)	1.61	II	638	(2840)	03	1320	60	120
18.1	991	(112)	1.60	II	969	(4310)	21.9	817	(92.3)	1.61	II	960	(4270)	03	1430	80	120
14.5	1240	(140)	1.60	II	980	(4360)	17.5	1020	(115)	1.61	II	980	(4360)	03	1430	100	120
12.1	1490	(168)	1.60	II	980	(4360)	14.6	1230	(138)	1.61	II	980	(4360)	03	1430	120	120
9.67	1860	(210)	1.60	II	980	(4360)	11.7	1530	(173)	1.61	II	980	(4360)	03	1430	150	120
7.25	2480	(280)	1.39	I	980	(4360)	8.75	2040	(231)	1.61	II	980	(4360)	03	1430	200	120
6.04	2970	(336)	1.16	I	980	(4360)	7.29	2450	(277)	1.41	II	980	(4360)	03	1430	240	120
4.83	3720	(420)	1.60	II	1400	(6230)	5.83	3060	(346)	1.61	II	1400	(6230)	03	1540	300	120
4.03	4460	(504)	1.54	II	1400	(6230)	4.86	3680	(415)	1.61	II	1400	(6230)	03	1540	360	120
3.02	5950	(672)	1.16	I	1400	(6230)	3.65	4900	(554)	1.40	II	1400	(6230)	03	1540	480	120
2.42	6880	(778)	*	-	1400	(6230)	2.92	6130	(692)	1.12	I	1400	(6230)	03	1540	600	120
2.01	6880	(778)	*	-	1400	(6230)	2.43	6880	(778)	*	-	1400	(6230)	03	1540	720	120
1.61	6880	(778)	*	-	1400	(6230)	1.94	6880	(778)	*	-	1400	(6230)	03	1540	900	120
1.21	6880	(778)	*	-	1400	(6230)	1.46	6880	(778)	*	-	1400	(6230)	03	1540	1200	120
1.01	6880	(778)	*	-	1400	(6230)	1.22	6880	(778)	*	-	1400	(6230)	03	1540	1440	120

Hyponic®
Selection Tables

Note: [1] Selections with service factor marked with an asterisk (*) should be limited to the identified output torque.

[2] Maximum allowable input speed is 3600rpm unless otherwise noted.

Variable Frequency Drive (VFD) notes (see page 3.8 for Constant Torque Speed Ranges)

All 1HP+ motors require EP suffix in model number and can be used with a VFD, unless noted.

Selection Tables

Three-Phase

Dimensions:	Frame Size	Page	Frame Size	Page
	1100	3.36	1400	3.40
	1200	3.37	1500	3.42
	1300	3.38	1600	3.44

Frequency	50 Hz	60 Hz	1/2 HP 0.4 kW
Input Speed	1450 RPM	1750 RPM	
Number of Poles	4		

50Hz						60Hz						Selection					
Output Speed (RPM)	Output Torque		Service Factor ^[1]		Solid Shaft Overhung Load		Output Speed (RPM)	Output Torque		Service Factor ^[1]		Solid Shaft Overhung Load		Base			Max Hz ^[2]
	in-lbs	(N·m)	SF	AGMA Class	lbs	(N)		in-lbs	(N·m)	SF	AGMA Class	lbs	(N)	Motor Power Code	Frame Size	Ratio	
290	99	(11.2)	1.00	I	198	(883)	350	77	(8.65)	1.07	I	187	(834)	05	1220	5	120
			2.00	III	330	(1470)				2.14	III	308	(1370)	05	1320	5	120
207	139	(15.7)	1.00	I	220	(981)	250	107	(12.1)	1.07	I	209	(932)	05	1220	7	120
			2.00	III	375	(1670)				2.14	III	353	(1570)	05	1320	7	120
145	198	(22.4)	1.00	I	243	(1080)	175	153	(17.3)	1.07	I	232	(1030)	05	1220	10	120
			2.00	III	407	(1810)				2.14	III	387	(1720)	05	1320	10	120
121	238	(26.9)	1.00	I	254	(1130)	146	184	(20.8)	1.07	I	243	(1080)	05	1220	12	120
			2.00	III	429	(1910)				2.14	III	407	(1810)	05	1320	12	120
96.7	297	(33.6)	1.00	I	277	(1230)	117	230	(26.0)	1.07	I	265	(1180)	05	1220	15	120
			2.00	III	463	(2060)				2.14	III	441	(1960)	05	1320	15	120
72.5	396	(44.8)	1.00	I	308	(1370)	87.5	306	(34.6)	1.07	I	297	(1320)	05	1220	20	120
			2.00	III	508	(2260)				2.14	III	486	(2160)	05	1320	20	120
58.0	495	(56.0)	1.00	I	330	(1470)	70.0	383	(43.3)	1.07	I	308	(1370)	05	1220	25	120
			2.00	III	528	(2350)				2.14	III	508	(2260)	05	1320	25	120
48.3	595	(67.2)	1.00	I	342	(1520)	58.3	459	(51.9)	1.07	I	330	(1470)	05	1220	30	120
			2.00	III	551	(2450)				2.14	III	528	(2350)	05	1320	30	120
36.3	793	(89.6)	1.00	I	596	(2650)	43.8	613	(69.2)	1.07	I	573	(2550)	05	1320	40	120
			2.00	III	892	(3970)				2.14	III	859	(3820)	05	1420	40	120
29.0	991	(112)	1.00	I	638	(2840)	35.0	766	(86.5)	1.07	I	618	(2750)	05	1320	50	120
			2.00	III	937	(4170)				2.14	III	904	(4020)	05	1420	50	120
24.2	1190	(134)	1.00	I	661	(2940)	29.2	919	(104)	1.07	I	638	(2840)	05	1320	60	120
			2.00	III	969	(4310)				2.14	III	937	(4170)	05	1420	60	120
18.1	1590	(179)	1.00	I	969	(4310)	21.9	1230	(138)	1.07	I	960	(4270)	05	1430	80	120
			2.00	III	1400	(6230)				2.14	III	1380	(6130)	05	1530	80	120
14.5	1980	(224)	1.00	I	980	(4360)	17.5	1530	(173)	1.07	I	980	(4360)	05	1430	100	120
			2.00	III	1400	(6230)				2.14	III	1400	(6230)	05	1530	100	120
12.1	2380	(269)	1.00	I	980	(4360)	14.6	1840	(208)	1.07	I	980	(4360)	05	1430	120	120
			2.00	III	1400	(6230)				2.14	III	1400	(6230)	05	1530	120	120
9.67	2970	(336)	1.00	I	980	(4360)	11.7	2300	(260)	1.07	I	980	(4360)	05	1430	150	120
			2.00	III	1400	(6230)				2.14	III	1400	(6230)	05	1530	150	120

Hyponic®

Selection Tables

Note: [1] Selections with service factor marked with an asterisk (*) should be limited to the identified output torque.

[2] Maximum allowable input speed is 3600rpm unless otherwise noted.

Variable Frequency Drive (VFD) notes (see page 3.8 for Constant Torque Speed Ranges)

All 1HP+ motors require EP suffix in model number and can be used with a VFD, unless noted.

Selection Tables

Three-Phase

1/2 HP 0.4 kW	Frequency	50 Hz	60 Hz
	Input Speed	1450 RPM	1750 RPM
	Number of Poles	4	

<i>Dimensions:</i>	Frame Size	Page	Frame Size	Page
	1100	3.36	1400	3.40
	1200	3.37	1500	3.42
	1300	3.38	1600	3.44

50Hz				60Hz				Selection									
Output Speed (RPM)	Output Torque		Service Factor ^[1]		Solid Shaft Overhung Load		Output Speed (RPM)	Output Torque		Service Factor ^[1]		Solid Shaft Overhung Load		Base			Max Hz ^[2]
	in·lbs	(N·m)	SF	AGMA Class	lbs	(N)		in·lbs	(N·m)	SF	AGMA Class	lbs	(N)	Motor Power Code	Frame Size	Ratio	
7.25	3460	(390)	*	-	980	(4360)	8.75	3060	(346)	1.07	I	980	(4360)	05	1430	200	120
	3960	(448)	1.63	II	1400	(6230)		2.12	III	1400	(6230)	05	1530	200	120		
6.04	3460	(390)	*	-	980	(4360)	7.29	3460	(390)	*	-	980	(4360)	05	1430	240	120
	4760	(537)	1.36	I	1400	(6230)		3680	(415)	1.76	II	1400	(6230)	05	1530	240	120
4.83	5950	(672)	1.00	I	1400	(6230)	5.83	4590	(519)	1.07	I	1400	(6230)	05	1540	300	120
			2.00	III	2210	(9810)				2.14	III	2210	(9810)	05	1640	300	120
4.03	6880	(778)	*	-	1400	(6230)	4.86	5510	(623)	1.07	I	1400	(6230)	05	1540	360	120
	6720	(759)	1.95	II	2210	(9810)		2.14	III	2210	(9810)	05	1640	360	120		
3.02	6880	(778)	*	-	1400	(6230)	3.65	6880	(778)	*	-	1400	(6230)	05	1540	480	120
	8950	(1010)	1.46	II	2210	(9810)		6920	(782)	1.90	II	2210	(9810)	05	1640	480	120
2.42	6880	(778)	*	-	1400	(6230)	2.92	6880	(778)	*	-	1400	(6230)	05	1540	600	120
	11200	(1260)	1.17	I	2210	(9810)		8650	(977)	1.52	II	2210	(9810)	05	1640	600	120
2.01	6880	(778)	*	-	1400	(6230)	2.43	6880	(778)	*	-	1400	(6230)	05	1540	720	120
	13100	(1480)	*	-	2210	(9810)		10400	(1170)	1.26	I	2210	(9810)	05	1640	720	120
1.61	6880	(778)	*	-	1400	(6230)	1.94	6880	(778)	*	-	1400	(6230)	05	1540	900	120
	13100	(1480)	*	-	2210	(9810)		13000	(1470)	1.01	I	2210	(9810)	05	1640	900	120
1.21	6880	(778)	*	-	1400	(6230)	1.46	6880	(778)	*	-	1400	(6230)	05	1540	1200	120
	13100	(1480)	*	-	2210	(9810)		13100	(1480)	*	-	2210	(9810)	05	1640	1200	120
1.01	6880	(778)	*	-	1400	(6230)	1.22	6880	(778)	*	-	1400	(6230)	05	1540	1440	120
	13100	(1480)	*	-	2210	(9810)		13100	(1480)	*	-	2210	(9810)	05	1640	1440	120

Hyponic®
Selection Tables

Note: [1] Selections with service factor marked with an asterisk (*) should be limited to the identified output torque.

[2] Maximum allowable input speed is 3600rpm unless otherwise noted.

Variable Frequency Drive (VFD) notes (see page 3.8 for Constant Torque Speed Ranges)

All 1HP+ motors require EP suffix in model number and can be used with a VFD, unless noted.

Selection Tables

Three-Phase

Dimensions:	Frame Size	Page	Frame Size	Page
	1100	3.36	1400	3.40
	1200	3.37	1500	3.42
	1300	3.38	1600	3.44

Frequency	50 Hz	60 Hz	3/4 HP 0.55 kW
Input Speed	1450 RPM	1750 RPM	
Number of Poles	4		

Output Speed (RPM)	50Hz						60Hz						Selection				
	Output Torque		Service Factor ⁽¹⁾		Solid Shaft Overhung Load		Output Torque		Service Factor ⁽¹⁾		Solid Shaft Overhung Load		Motor Power Code	Base		Max Hz ⁽²⁾	
	in-lbs	(N·m)	SF	AGMA Class	lbs	(N)	in-lbs	(N·m)	SF	AGMA Class	lbs	(N)		Frame Size	Ratio		
290	136	(15.4)	1.45	II	330	(1470)	350	115	(13.0)	1.43	II	308	(1370)	08	1320	5	120
207	191	(21.6)	1.45	II	375	(1670)	250	161	(18.2)	1.43	II	353	(1570)	08	1320	7	120
145	273	(30.8)	1.45	II	407	(1810)	175	230	(26.0)	1.43	II	387	(1720)	08	1320	10	120
121	327	(36.9)	1.45	II	429	(1910)	146	276	(31.1)	1.43	II	407	(1810)	08	1320	12	120
96.7	409	(46.2)	1.45	II	463	(2060)	117	345	(38.9)	1.43	II	441	(1960)	08	1320	15	120
72.5	545	(61.6)	1.45	II	508	(2260)	87.5	459	(51.9)	1.43	II	486	(2160)	08	1320	20	120
58.0	681	(77.0)	1.45	II	528	(2350)	70.0	574	(64.9)	1.43	II	508	(2260)	08	1320	25	120
48.3	818	(92.4)	1.45	II	551	(2450)	58.3	689	(77.9)	1.43	II	528	(2350)	08	1320	30	120
36.3	1090	(123)	1.45	II	892	(3970)	43.8	919	(104)	1.43	II	859	(3820)	08	1420	40	120
29.0	1360	(154)	1.45	II	937	(4170)	35.0	1150	(130)	1.43	II	904	(4020)	08	1420	50	120
24.2	1640	(185)	1.45	II	969	(4310)	29.2	1380	(156)	1.43	II	937	(4170)	08	1420	60	120
18.1	2180	(246)	1.45	II	1400	(6230)	21.9	1840	(208)	1.43	II	1380	(6130)	08	1530	80	120
14.5	2730	(308)	1.45	II	1400	(6230)	17.5	2300	(260)	1.43	II	1400	(6230)	08	1530	100	120
12.1	3270	(369)	1.45	II	1400	(6230)	14.6	2760	(311)	1.43	II	1400	(6230)	08	1530	120	120
9.67	4090	(462)	1.45	II	1400	(6230)	11.7	3450	(389)	1.43	II	1400	(6230)	08	1530	150	120
7.25	5450	(616)	1.19	I	1400	(6230)	8.75	4590	(519)	1.41	II	1400	(6230)	08	1530	200	120
6.04	6480	(732)	*	-	1400	(6230)	7.29	5510	(623)	1.18	I	1400	(6230)	08	1530	240	120
4.83	7690	(869)	1.45	II	2210	(9810)	5.83	6490	(733)	1.43	II	2210	(9810)	08	1640	300	120
4.03	9230	(1040)	1.42	II	2210	(9810)	4.86	7780	(879)	1.43	II	2210	(9810)	08	1640	360	120
3.02	12300	(1390)	1.06	I	2210	(9810)	3.65	10400	(1170)	1.26	I	2210	(9810)	08	1640	480	120
2.42	13100	(1480)	*	-	2210	(9810)	2.92	13000	(1470)	1.01	I	2210	(9810)	08	1640	600	120
2.01	13100	(1480)	*	-	2210	(9810)	2.43	13100	(1480)	*	-	2210	(9810)	08	1640	720	120
1.61	13100	(1480)	*	-	2210	(9810)	1.94	13100	(1480)	*	-	2210	(9810)	08	1640	900	120
1.21	13100	(1480)	*	-	2210	(9810)	1.46	13100	(1480)	*	-	2210	(9810)	08	1640	1200	120
1.01	13100	(1480)	*	-	2210	(9810)	1.22	13100	(1480)	*	-	2210	(9810)	08	1640	1440	120

Hyponic®

Selection
Tables

Note: [1] Selections with service factor marked with an asterisk (*) should be limited to the identified output torque.

[2] Maximum allowable input speed is 3600rpm unless otherwise noted.

Variable Frequency Drive (VFD) notes (see page 3.8 for Constant Torque Speed Ranges)

All 1HP+ motors require EP suffix in model number and can be used with a VFD, unless noted.

Selection Tables

Three-Phase

1 HP 0.75 kW	Frequency	50 Hz	60 Hz
	Input Speed	1450 RPM	1750 RPM
	Number of Poles	4	

<i>Dimensions:</i>	Frame Size	Page	Frame Size	Page
	1100	3.36	1400	3.40
	1200	3.37	1500	3.42
	1300	3.38	1600	3.44

50Hz					60Hz					Selection							
Output Speed (RPM)	Output Torque		Service Factor ^[1]		Solid Shaft Overhung Load		Output Speed (RPM)	Output Torque		Service Factor ^[1]		Base		Max Hz ^[2]			
	in-lbs	(N·m)	SF	AGMA Class	lbs	(N)		in-lbs	(N·m)	SF	AGMA Class	lbs	(N)		Motor Power Code	Frame Size	Ratio
290	186	(21.0)	1.07	I	330	(1470)	350	153	(17.3)	1.07	I	308	(1370)	1	1320	5	120
			2.05	III	486	(2160)				2.06	III	463	(2060)	1	1420	5	120
207	260	(29.4)	1.07	I	375	(1670)	250	214	(24.2)	1.07	I	353	(1570)	1	1320	7	120
			2.05	III	551	(2450)				2.06	III	517	(2300)	1	1420	7	120
145	372	(42.0)	1.07	I	407	(1810)	175	306	(34.6)	1.07	I	387	(1720)	1	1320	10	120
			2.05	III	618	(2750)				2.06	III	585	(2600)	1	1420	10	120
121	446	(50.4)	1.07	I	429	(1910)	146	368	(41.5)	1.07	I	407	(1810)	1	1320	12	120
			2.05	III	638	(2840)				2.06	III	618	(2750)	1	1420	12	120
96.7	557	(63.0)	1.07	I	463	(2060)	117	459	(51.9)	1.07	I	441	(1960)	1	1320	15	120
			2.05	III	695	(3090)				2.06	III	661	(2940)	1	1420	15	120
72.5	743	(84.0)	1.07	I	508	(2260)	87.5	613	(69.2)	1.07	I	486	(2160)	1	1320	20	120
			2.05	III	749	(3330)				2.06	III	717	(3190)	1	1420	20	120
58.0	929	(105)	1.07	I	528	(2350)	70.0	766	(86.5)	1.07	I	508	(2260)	1	1320	25	120
			2.05	III	794	(3530)				2.06	III	760	(3380)	1	1420	25	120
48.3	1110	(126)	1.07	I	551	(2450)	58.3	919	(104)	1.07	I	528	(2350)	1	1320	30	120
			2.05	III	839	(3730)				2.06	III	805	(3580)	1	1420	30	120
36.3	1490	(168)	1.07	I	892	(3970)	43.8	1230	(138)	1.07	I	859	(3820)	1	1420	40	120
			2.05	III	1290	(5740)				2.06	III	1250	(5540)	1	1520	40	120
29.0	1860	(210)	1.07	I	937	(4170)	35.0	1530	(173)	1.07	I	904	(4020)	1	1420	50	120
			2.05	III	1360	(6030)				2.06	III	1310	(5830)	1	1520	50	120
24.2	2230	(252)	1.07	I	969	(4310)	29.2	1840	(208)	1.07	I	937	(4170)	1	1420	60	120
			2.05	III	1400	(6230)				2.06	III	1360	(6030)	1	1520	60	120
18.1	2970	(336)	1.07	I	1400	(6230)	21.9	2450	(277)	1.07	I	1380	(6130)	1	1530	80	120
			2.05	III	1400	(6230)				2.06	III	1380	(6130)	1	1531	80	120
14.5	3720	(420)	1.07	I	1400	(6230)	17.5	3060	(346)	1.07	I	1400	(6230)	1	1530	100	120
			2.98	III	2210	(9810)				3.00	III	2210	(9810)	1	1630	100	120
12.1	4460	(504)	1.07	I	1400	(6230)	14.6	3680	(415)	1.07	I	1400	(6230)	1	1530	120	120
			2.98	III	2210	(9810)				3.00	III	2210	(9810)	1	1630	120	120
9.67	5570	(630)	1.07	I	1400	(6230)	11.7	4590	(519)	1.07	I	1400	(6230)	1	1530	150	120
			2.35	III	2210	(9810)				2.85	III	2210	(9810)	1	1631	150	120

Note: [1] Selections with service factor marked with an asterisk (*) should be limited to the identified output torque.

[2] Maximum allowable input speed is 3600rpm unless otherwise noted.

Variable Frequency Drive (VFD) notes (see page 3.8 for Constant Torque Speed Ranges)

All 1HP+ motors require EP suffix in model number and can be used with a VFD, unless noted.

Selection Tables

Three-Phase

<i>Dimensions:</i>	Frame Size	Page	Frame Size	Page
	1100	3.36	1400	3.40
	1200	3.37	1500	3.42
	1300	3.38	1600	3.44

Frequency	50 Hz	60 Hz	1 HP 0.75 kW
Input Speed	1450 RPM	1750 RPM	
Number of Poles	4		

50Hz					60Hz					Selection							
Output Speed (RPM)	Output Torque		Service Factor ^[1]		Solid Shaft Overhung Load		Output Speed (RPM)	Output Torque		Service Factor ^[1]		Base		Max Hz ^[2]			
	in·lbs	(N·m)	SF	AGMA Class	lbs	(N)		in·lbs	(N·m)	SF	AGMA Class	lbs	(N)		Motor Power Code	Frame Size	Ratio
7.25	6480	(732)	*	-	1400	(6230)	8.75	6130	(692)	1.06	I	1400	(6230)	1	1530	200	120
	7430	(840)	1.76	II	2210	(9810)		2.14	III	2210	(9810)	1	1631	200	120		
6.04	6480	(732)	*	-	1400	(6230)	7.29	6480	(732)	*	-	1400	(6230)	1	1530	240	120
	8920	(1010)	1.47	II	2210	(9810)		7350	(830)	1.78	II	2210	(9810)	1	1631	240	120
4.83	10500	(1190)	1.07	I	2210	(9810)	5.83	8650	(977)	1.07	I	2210	(9810)	1	1640	300	120
4.03	12600	(1420)	1.04	I	2210	(9810)	4.86	10400	(1170)	1.07	I	2210	(9810)	1	1640	360	120
3.02	13100	(1480)	*	-	2210	(9810)	3.65	13100	(1480)	*	-	2210	(9810)	1	1640	480	120
2.42	13100	(1480)	*	-	2210	(9810)	2.92	13100	(1480)	*	-	2210	(9810)	1	1640	600	120
2.01	13100	(1480)	*	-	2210	(9810)	2.43	13100	(1480)	*	-	2210	(9810)	1	1640	720	120
1.61	13100	(1480)	*	-	2210	(9810)	1.94	13100	(1480)	*	-	2210	(9810)	1	1640	900	120
1.21	13100	(1480)	*	-	2210	(9810)	1.46	13100	(1480)	*	-	2210	(9810)	1	1640	1200	120
1.01	13100	(1480)	*	-	2210	(9810)	1.22	13100	(1480)	*	-	2210	(9810)	1	1640	1440	120

Hyponic®

Selection Tables

Note: [1] Selections with service factor marked with an asterisk (*) should be limited to the identified output torque.

[2] Maximum allowable input speed is 3600rpm unless otherwise noted.

Variable Frequency Drive (VFD) notes (see page 3.8 for Constant Torque Speed Ranges)

All 1HP+ motors require EP suffix in model number and can be used with a VFD, unless noted.

Selection Tables

Three-Phase

1.5 HP 1.1 kW	Frequency	50 Hz	60 Hz
	Input Speed	1450 RPM	1750 RPM
	Number of Poles	4	

<i>Dimensions:</i>	Frame Size	Page	Frame Size	Page
	1100	3.36	1400	3.40
	1200	3.37	1500	3.42
	1300	3.38	1600	3.44

50Hz				60Hz				Selection									
Output Speed (RPM)	Output Torque		Service Factor ^[1]		Solid Shaft Overhung Load		Output Speed (RPM)	Output Torque		Service Factor ^[1]		Solid Shaft Overhung Load		Base			Max Hz ^[2]
	in·lbs	(N·m)	SF	AGMA Class	lbs	(N)		in·lbs	(N·m)	SF	AGMA Class	lbs	(N)	Motor Power Code	Frame Size	Ratio	
290	273	(30.8)	1.40	II	486	(2160)	350	230	(26.0)	1.38	I	463	(2060)	1H	1420	5	120
207	382	(43.1)	1.40	II	551	(2450)	250	322	(36.3)	1.38	I	517	(2300)	1H	1420	7	120
145	545	(61.6)	1.40	II	618	(2750)	175	459	(51.9)	1.38	I	585	(2600)	1H	1420	10	120
121	654	(73.9)	1.40	II	638	(2840)	146	551	(62.3)	1.38	I	618	(2750)	1H	1420	12	120
96.7	818	(92.4)	1.40	II	695	(3090)	117	689	(77.9)	1.38	I	661	(2940)	1H	1420	15	120
72.5	1090	(123)	1.40	II	749	(3330)	87.5	919	(104)	1.38	I	717	(3190)	1H	1420	20	120
58.0	1360	(154)	1.40	II	794	(3530)	70.0	1150	(130)	1.38	I	760	(3380)	1H	1420	25	120
48.3	1640	(185)	1.40	II	839	(3730)	58.3	1380	(156)	1.38	I	805	(3580)	1H	1420	30	120
36.3	2180	(246)	1.40	II	1290	(5740)	43.8	1840	(208)	1.38	I	1250	(5540)	1H	1520	40	120
29.0	2730	(308)	1.40	II	1360	(6030)	35.0	2300	(260)	1.38	I	1310	(5830)	1H	1520	50	120
24.2	3270	(369)	1.40	II	1400	(6230)	29.2	2760	(311)	1.38	I	1360	(6030)	1H	1520	60	120
18.1	4360	(493)	1.40	II	1400	(6230)	21.9	3680	(415)	1.38	I	1380	(6130)	1H	1531	80	120
14.5	5450	(616)	2.03	III	2210	(9810)	17.5	4590	(519)	2.00	III	2210	(9810)	1H	1630	100	120
12.1	6540	(739)	2.03	III	2210	(9810)	14.6	5510	(623)	2.00	III	2210	(9810)	1H	1630	120	120
9.67	8180	(924)	1.60	II	2210	(9810)	11.7	6890	(779)	1.90	II	2210	(9810)	1H	1631	150	120
7.25	10900	(1230)	1.20	I	2210	(9810)	8.75	9190	(1040)	1.43	II	2210	(9810)	1H	1631	200	120
6.04	13100	(1480)	1.00	I	2210	(9810)	7.29	11000	(1250)	1.19	I	2210	(9810)	1H	1631	240	120

Hyponic®
Selection Tables

Note: [1] Selections with service factor marked with an asterisk (*) should be limited to the identified output torque.

[2] Maximum allowable input speed is 3600rpm unless otherwise noted.

Variable Frequency Drive (VFD) notes (see page 3.8 for Constant Torque Speed Ranges)

All 1HP+ motors require EP suffix in model number and can be used with a VFD, unless noted.

Selection Tables

Three-Phase

Dimensions:	Frame Size	Page	Frame Size	Page
	1100	3.36	1400	3.40
	1200	3.37	1500	3.42
	1300	3.38	1600	3.44

Frequency	50 Hz	60 Hz	2 HP 1.5 kW
Input Speed	1450 RPM	1750 RPM	
Number of Poles	4		

Output Speed (RPM)	50Hz						60Hz						Selection				
	Output Torque		Service Factor ^[1]		Solid Shaft Overhung Load		Output Torque		Service Factor ^[1]		Solid Shaft Overhung Load		Motor Power Code	Base		Max Hz ^[2]	
	in-lbs	(N·m)	SF	AGMA Class	lbs	(N)	in-lbs	(N·m)	SF	AGMA Class	lbs	(N)		Frame Size	Ratio		
290	372	(42.0)	1.03	I	486	(2160)	350	306	(34.6)	1.03	I	463	(2060)	2	1420	5	120
			1.49	II	706	(3140)				1.50	II	661	(2940)	2	1520	5	120
			2.49	III	706	(3140)				2.50	III	661	(2940)	2	1521	5	60
207	520	(58.8)	1.03	I	551	(2450)	250	429	(48.4)	1.03	I	517	(2300)	2	1420	7	120
			1.49	II	794	(3530)				1.50	II	749	(3330)	2	1520	7	120
			2.49	III	794	(3530)				2.50	III	749	(3330)	2	1521	7	60
145	743	(84.0)	1.03	I	618	(2750)	175	613	(69.2)	1.03	I	585	(2600)	2	1420	10	120
			1.49	II	881	(3920)				1.50	II	839	(3730)	2	1520	10	120
			2.49	III	881	(3920)				2.50	III	839	(3730)	2	1521	10	60
121	892	(101)	1.03	I	638	(2840)	146	735	(83.0)	1.03	I	618	(2750)	2	1420	12	120
			1.49	II	926	(4120)				1.50	II	892	(3970)	2	1520	12	120
			2.49	III	926	(4120)				2.50	III	892	(3970)	2	1521	12	60
96.7	1110	(126)	1.03	I	695	(3090)	117	919	(104)	1.03	I	661	(2940)	2	1420	15	120
			1.49	II	991	(4410)				1.50	II	949	(4220)	2	1520	15	120
			2.49	III	991	(4410)				2.50	III	949	(4220)	2	1521	15	60
72.5	1490	(168)	1.03	I	749	(3330)	87.5	1230	(138)	1.03	I	717	(3190)	2	1420	20	120
			1.49	II	1080	(4810)				1.50	II	1040	(4610)	2	1520	20	120
			2.49	III	1080	(4810)				2.50	III	1040	(4610)	2	1521	20	60
58.0	1860	(210)	1.03	I	794	(3530)	70.0	1530	(173)	1.03	I	760	(3380)	2	1420	25	120
			1.49	II	1150	(5100)				1.50	II	1100	(4900)	2	1520	25	120
			2.49	III	1150	(5100)				2.50	III	1100	(4900)	2	1521	25	60
48.3	2230	(252)	1.03	I	839	(3730)	58.3	1840	(208)	1.03	I	805	(3580)	2	1420	30	120
			1.49	II	1200	(5340)				1.50	II	1160	(5150)	2	1520	30	120
			2.49	III	1880	(8380)				2.50	III	1820	(8090)	2	1632	30	120
36.3	2970	(336)	1.03	I	1290	(5740)	43.8	2450	(277)	1.03	I	1250	(5540)	2	1520	40	120
			1.49	II	1290	(5740)				1.50	II	1250	(5540)	2	1531	40	120
			2.49	III	1990	(8830)				2.50	III	1910	(8480)	2	1632	40	120
29.0	3720	(420)	1.03	I	1360	(6030)	35.0	3060	(346)	1.03	I	1310	(5830)	2	1520	50	120
			1.49	II	1360	(6030)				1.50	II	1310	(5830)	2	1531	50	120
			2.49	III	2050	(9120)				2.50	III	2000	(8880)	2	1632	50	120

Hyponic®

Selection Tables

Note: [1] Selections with service factor marked with an asterisk (*) should be limited to the identified output torque.

[2] Maximum allowable input speed is 3600rpm unless otherwise noted.

Variable Frequency Drive (VFD) notes (see page 3.8 for Constant Torque Speed Ranges)

All 1HP+ motors require EP suffix in model number and can be used with a VFD, unless noted.

Selection Tables

Three-Phase

2 HP 1.5 kW	Frequency	50 Hz	60 Hz
	Input Speed	1450 RPM	1750 RPM
	Number of Poles	4	

<i>Dimensions:</i>	Frame Size	Page	Frame Size	Page
	1100	3.36	1400	3.40
	1200	3.37	1500	3.42
	1300	3.38	1600	3.44

50Hz				60Hz				Selection									
Output Speed (RPM)	Output Torque		Service Factor ^[1]		Solid Shaft Overhung Load		Output Speed (RPM)	Output Torque		Service Factor ^[1]		Solid Shaft Overhung Load		Base			Max Hz ^[2]
	in·lbs	(N·m)	SF	AGMA Class	lbs	(N)		in·lbs	(N·m)	SF	AGMA Class	lbs	(N)	Motor Power Code	Frame Size	Ratio	
24.2	4460	(504)	1.03	I	1400	(6230)	29.2	3680	(415)	1.03	I	1360	(6030)	2	1520	60	120
			1.49	II	1400	(6230)				1.50	II	1360	(6030)	2	1531	60	120
			2.49	III	2120	(9410)				2.50	III	2060	(9170)	2	1632	60	120
18.1	5950	(672)	1.03	I	1400	(6230)	21.9	4900	(554)	1.03	I	1380	(6130)	2	1531	80	120
			1.49	II	2210	(9810)				1.50	II	2170	(9660)	2	1630	80	120
14.5	7430	(840)	1.49	II	2210	(9810)	17.5	6130	(692)	1.50	II	2210	(9810)	2	1630	100	120
12.1	8920	(1010)	1.49	II	2210	(9810)	14.6	7350	(830)	1.50	II	2210	(9810)	2	1630	120	120
9.67	11100	(1260)	1.18	I	2210	(9810)	11.7	9190	(1040)	1.43	II	2210	(9810)	2	1631	150	120
7.25	13100	(1480)	*	-	2210	(9810)	8.75	12300	(1380)	1.07	I	2210	(9810)	2	1631	200	120
6.04	13100	(1480)	*	-	2210	(9810)	7.29	13100	(1480)	*	-	2210	(9810)	2	1631	240	120
			*	-	2210	(9810)				*	-	2210	(9810)	2	1631	240	120

Hyponic®

Selection Tables

Note: [1] Selections with service factor marked with an asterisk (*) should be limited to the identified output torque.

[2] Maximum allowable input speed is 3600rpm unless otherwise noted.

Variable Frequency Drive (VFD) notes (see page 3.8 for Constant Torque Speed Ranges)

All 1HP+ motors require EP suffix in model number and can be used with a VFD, unless noted.

Selection Tables

Three-Phase

Dimensions:	Frame Size	Page	Frame Size	Page
	1100	3.36	1400	3.40
	1200	3.37	1500	3.42
	1300	3.38	1600	3.44

Frequency	50 Hz	60 Hz	3 HP 2.2 kW
Input Speed	1450 RPM	1750 RPM	
Number of Poles	4		

50Hz					60Hz					Selection							
Output Speed (RPM)	Output Torque		Service Factor ^[1]		Solid Shaft Overhung Load		Output Speed (RPM)	Output Torque		Service Factor ^[1]		Solid Shaft Overhung Load		Base			Max Hz ^[2]
	in·lbs	(N·m)	SF	AGMA Class	lbs	(N)		in·lbs	(N·m)	SF	AGMA Class	lbs	(N)	Motor Power Code	Frame Size	Ratio	
290	545	(61.6)	1.02	I	706	(3140)	350	459	(51.9)	1.00	I	661	(2940)	3	1520	5	60
			1.70	II	706	(3140)				1.67	II	661	(2940)	3	1521	5	60
207	763	(86.2)	1.02	I	794	(3530)	250	643	(72.7)	1.00	I	749	(3330)	3	1520	7	60
			1.70	II	794	(3530)				1.67	II	749	(3330)	3	1521	7	60
145	1090	(123)	1.02	I	881	(3920)	175	919	(104)	1.00	I	839	(3730)	3	1520	10	60
			1.70	II	881	(3920)				1.67	II	839	(3730)	3	1521	10	60
121	1310	(148)	1.02	I	926	(4120)	146	1100	(125)	1.00	I	892	(3970)	3	1520	12	60
			1.70	II	926	(4120)				1.67	II	892	(3970)	3	1521	12	60
96.7	1640	(185)	1.02	I	991	(4410)	117	1380	(156)	1.00	I	949	(4220)	3	1520	15	60
			1.70	II	991	(4410)				1.67	II	949	(4220)	3	1521	15	60
72.5	2180	(246)	1.02	I	1080	(4810)	87.5	1840	(208)	1.00	I	1040	(4610)	3	1520	20	60
			1.70	II	1080	(4810)				1.67	II	1040	(4610)	3	1521	20	60
			2.54	III	1730	(7700)				2.50	III	1650	(7350)	3	1633	20	80
58.0	2730	(308)	1.02	I	1150	(5100)	70.0	2300	(260)	1.00	I	1100	(4900)	3	1520	25	60
			1.70	II	1150	(5100)				1.67	II	1100	(4900)	3	1521	25	60
			2.54	III	1820	(8090)				2.50	III	1740	(7750)	3	1633	25	80
48.3	3270	(369)	1.02	I	1200	(5340)	58.3	2760	(311)	1.00	I	1160	(5150)	3	1520	30	60
			1.70	II	1880	(8380)				1.67	II	1820	(8090)	3	1632	30	120
			2.54	III	1880	(8380)				2.50	III	1820	(8090)	3	1633	30	80
36.3	4360	(493)	1.02	I	1290	(5740)	43.8	3680	(415)	1.00	I	1250	(5540)	3	1531	40	60
			1.70	II	1990	(8830)				1.67	II	1910	(8480)	3	1632	40	120
			2.54	III	1990	(8830)				2.50	III	1910	(8480)	3	1633	40	80
29.0	5450	(616)	1.02	I	1360	(6030)	35.0	4590	(519)	1.00	I	1310	(5830)	3	1531	50	60
			1.70	II	2050	(9120)				1.67	II	2000	(8880)	3	1632	50	120
24.2	6540	(739)	1.02	I	1400	(6230)	29.2	5510	(623)	1.00	I	1360	(6030)	3	1531	60	60
			1.70	II	2120	(9410)				1.67	II	2060	(9170)	3	1632	60	120
18.1	8720	(985)	1.02	I	2210	(9810)	21.9	7350	(830)	1.00	I	2170	(9660)	3	1630	80	120
14.5	10900	(1230)	1.02	I	2210	(9810)	17.5	9190	(1040)	1.00	I	2210	(9810)	3	1630	100	120
12.1	13100	(1480)	1.02	I	2210	(9810)	14.6	11000	(1250)	1.00	I	2210	(9810)	3	1630	120	120
9.67	13100	(1480)	*	-	2210	(9810)	11.7	13100	(1480)	*	-	2210	(9810)	3	1631	150	120

Hyponic®

Selection
Tables

Note: [1] Selections with service factor marked with an asterisk (*) should be limited to the identified output torque.

[2] Maximum allowable input speed is 3600rpm unless otherwise noted.

Variable Frequency Drive (VFD) notes (see page 3.8 for Constant Torque Speed Ranges)

All 1HP+ motors require EP suffix in model number and can be used with a VFD, unless noted.

Selection Tables

Three-Phase

3 HP 2.2 kW	Frequency	50 Hz	60 Hz
	Input Speed	1450 RPM	1750 RPM
	Number of Poles	4	

<i>Dimensions:</i>	Frame Size	Page	Frame Size	Page
	1100	3.36	1400	3.40
	1200	3.37	1500	3.42
	1300	3.38	1600	3.44

50Hz				60Hz				Selection									
Output Speed (RPM)	Output Torque		Service Factor ^[1]		Solid Shaft Overhung Load		Output Speed (RPM)	Output Torque		Service Factor ^[1]		Solid Shaft Overhung Load		Base			Max Hz ^[2]
	in·lbs	(N·m)	SF	AGMA Class	lbs	(N)		in·lbs	(N·m)	SF	AGMA Class	lbs	(N)	Motor Power Code	Frame Size	Ratio	
7.25	13100	(1480)	*	-	2210	(9810)	8.75	13100	(1480)	*	-	2210	(9810)	3	1631	200	120
6.04	13100	(1480)	*	-	2210	(9810)	7.29	13100	(1480)	*	-	2210	(9810)	3	1631	240	120

Hyponic®

Selection Tables

Note: [1] Selections with service factor marked with an asterisk (*) should be limited to the identified output torque.

[2] Maximum allowable input speed is 3600rpm unless otherwise noted.

Variable Frequency Drive (VFD) notes (see page 3.8 for Constant Torque Speed Ranges)

All 1HP+ motors require EP suffix in model number and can be used with a VFD, unless noted.

Selection Tables

Three-Phase

Dimensions:	Frame Size	Page	Frame Size	Page
	1100	3.36	1400	3.40
	1200	3.37	1500	3.42
	1300	3.38	1600	3.44

Frequency	50 Hz	60 Hz	5 HP 3.7 kW
Input Speed	1450 RPM	1750 RPM	
Number of Poles	4		

50Hz					60Hz					Selection							
Output Speed (RPM)	Output Torque		Service Factor ^[1]		Solid Shaft Overhung Load		Output Speed (RPM)	Output Torque		Service Factor ^[1]		Base		Max Hz ^[2]			
	in-lbs	(N·m)	SF	AGMA Class	lbs	(N)		in-lbs	(N·m)	SF	AGMA Class	lbs	(N)		Motor Power Code	Frame Size	Ratio
290	917	(104)	1.01	I	706	(3140)	350	766	(86.5)	1.00	I	661	(2940)	5	1521	5	60
			1.51	II	706	(3140)				1.50	II	661	(2940)	5	1522	5	60
207	1280	(145)	1.01	I	794	(3530)	250	1070	(121)	1.00	I	749	(3330)	5	1521	7	60
			1.51	II	794	(3530)				1.50	II	749	(3330)	5	1522	7	60
145	1830	(207)	1.01	I	881	(3920)	175	1530	(173)	1.00	I	839	(3730)	5	1521	10	60
			1.51	II	881	(3920)				1.50	II	839	(3730)	5	1522	10	60
121	2200	(249)	1.01	I	926	(4120)	146	1840	(208)	1.00	I	892	(3970)	5	1521	12	60
			1.51	II	926	(4120)				1.50	II	892	(3970)	5	1522	12	60
96.7	2750	(311)	1.01	I	991	(4410)	117	2300	(260)	1.00	I	949	(4220)	5	1521	15	60
			1.51	II	991	(4410)				1.50	II	949	(4220)	5	1522	15	60
72.5	3670	(414)	1.01	I	1080	(4810)	87.5	3060	(346)	1.00	I	1040	(4610)	5	1521	20	60
			1.51	II	1730	(7700)				1.50	II	1650	(7350)	5	1633	20	80
58.0	4580	(518)	1.01	I	1150	(5100)	70.0	3830	(433)	1.00	I	1100	(4900)	5	1521	25	60
			1.51	II	1820	(8090)				1.50	II	1740	(7750)	5	1633	25	80
48.3	5500	(621)	1.01	I	1880	(8380)	58.3	4590	(519)	1.00	I	1820	(8090)	5	1632	30	60
			1.51	II	1880	(8380)				1.50	II	1820	(8090)	5	1633	30	80
36.3	7330	(829)	1.01	I	1990	(8830)	43.8	6130	(692)	1.00	I	1910	(8480)	5	1632	40	60
			1.51	II	1990	(8830)				1.50	II	1910	(8480)	5	1633	40	80
29.0	9170	(1040)	1.01	I	2050	(9120)	35.0	7660	(865)	1.00	I	2000	(8880)	5	1632	50	60
24.2	11000	(1240)	1.01	I	2120	(9410)	29.2	9190	(1040)	1.00	I	2060	(9170)	5	1632	60	60

Hyponic®

Selection
Tables

Note: [1] Selections with service factor marked with an asterisk (*) should be limited to the identified output torque.

[2] Maximum allowable input speed is 3600rpm unless otherwise noted.

Variable Frequency Drive (VFD) notes (see page 3.8 for Constant Torque Speed Ranges)

All 1HP+ motors require EP suffix in model number and can be used with a VFD, unless noted.

Selection Tables

Three-Phase

7.5 HP 5.5 kW	Frequency	50 Hz	60 Hz
	Input Speed	1450 RPM	1750 RPM
	Number of Poles	4	

<i>Dimensions:</i>	Frame Size	Page	Frame Size	Page
	1100	3.36	1400	3.40
	1200	3.37	1500	3.42
	1300	3.38	1600	3.44

50Hz				60Hz				Selection									
Output Speed (RPM)	Output Torque		Service Factor ^[1]		Solid Shaft Overhung Load		Output Speed (RPM)	Output Torque		Service Factor ^[1]		Base		Max Hz ^[2]			
	in·lbs	(N·m)	SF	AGMA Class	lbs	(N)		in·lbs	(N·m)	SF	AGMA Class	lbs	(N)		Motor Power Code	Frame Size	Ratio
290	1360	(154)	1.02	I	706	(3140)	350	1150	(130)	1.00	I	661	(2940)	8	1522	5	60
			2.04	III	1120	(5000)				2.00	III	1070	(4760)				
207	1910	(216)	1.02	I	794	(3530)	250	1610	(182)	1.00	I	749	(3330)	8	1522	7	60
			2.03	III	1260	(5590)				2.00	III	1180	(5250)				
145	2730	(308)	1.02	I	881	(3920)	175	2300	(260)	1.00	I	839	(3730)	8	1522	10	60
			2.03	III	1400	(6230)				2.00	III	1330	(5930)				
121	3270	(369)	1.02	I	926	(4120)	146	2760	(311)	1.00	I	892	(3970)	8	1522	12	60
			2.03	III	1490	(6620)				2.00	III	1420	(6330)				
96.7	4090	(462)	1.02	I	991	(4410)	117	3450	(389)	1.00	I	949	(4220)	8	1522	15	60
			2.03	III	1560	(6960)				2.00	III	1500	(6670)				
72.5	5450	(616)	1.02	I	1730	(7700)	87.5	4590	(519)	1.00	I	1650	(7350)	8	1633	20	60
			2.03	III	1730	(7700)				2.00	III	1650	(7350)				
58.0	6810	(770)	1.02	I	1820	(8090)	70.0	5740	(649)	1.00	I	1740	(7750)	8	1633	25	60
			1.92	II	1820	(8090)				1.90	II	1740	(7750)				
48.3	8180	(924)	1.02	I	1880	(8380)	58.3	6890	(779)	1.00	I	1820	(8090)	8	1633	30	60
36.3	10900	(1230)	1.02	I	1990	(8830)	43.8	9190	(1040)	1.00	I	1910	(8480)	8	1633	40	60

Hyponic®
Selection Tables

Note: [1] Selections with service factor marked with an asterisk (*) should be limited to the identified output torque.

[2] Maximum allowable input speed is 3600rpm unless otherwise noted.

Variable Frequency Drive (VFD) notes (see page 3.8 for Constant Torque Speed Ranges)

All 1HP+ motors require EP suffix in model number and can be used with a VFD, unless noted.

Selection Tables

Three-Phase

Dimensions:	Frame Size	Page	Frame Size	Page
	1100	3.36	1400	3.40
	1200	3.37	1500	3.42
	1300	3.38	1600	3.44

Frequency	50 Hz	60 Hz	10 HP 7.5 kW
Input Speed	1450 RPM	1750 RPM	
Number of Poles	4		

50Hz						60Hz						Selection					
Output Speed (RPM)	Output Torque		Service Factor ^[1]		Solid Shaft Overhung Load		Output Speed (RPM)	Output Torque		Service Factor ^[1]		Solid Shaft Overhung Load		Motor Power Code	Base		Max Hz ^[2]
	in·lbs	(N·m)	SF	AGMA Class	lbs	(N)		in·lbs	(N·m)	SF	AGMA Class	lbs	(N)		Frame Size	Ratio	
290	1860	(210)	1.49	II	1120	(5000)	350	1530	(173)	1.50	II	1070	(4760)	10	1634	5	60
207	2600	(294)	1.49	II	1260	(5590)	250	2140	(242)	1.50	II	1180	(5250)	10	1634	7	60
145	3720	(420)	1.49	II	1400	(6230)	175	3060	(346)	1.50	II	1330	(5930)	10	1634	10	60
121	4460	(504)	1.49	II	1490	(6620)	146	3680	(415)	1.50	II	1420	(6330)	10	1634	12	60
96.7	5570	(630)	1.49	II	1560	(6960)	117	4590	(519)	1.50	II	1500	(6670)	10	1634	15	60
72.5	7430	(840)	1.49	II	1730	(7700)	87.5	6130	(692)	1.50	II	1650	(7350)	10	1634	20	60
58.0	9290	(1050)	1.41	II	1820	(8090)	70.0	7660	(865)	1.43	II	1740	(7750)	10	1634	25	60

Hyponic®

 Selection
Tables

Note: [1] Selections with service factor marked with an asterisk (*) should be limited to the identified output torque.

[2] Maximum allowable input speed is 3600rpm unless otherwise noted.

Variable Frequency Drive (VFD) notes (see page 3.8 for Constant Torque Speed Ranges)

All 1HP+ motors require EP suffix in model number and can be used with a VFD, unless noted.

Selection Tables

Three-Phase

15 HP 11 kW	Frequency	50 Hz	60 Hz
	Input Speed	1450 RPM	1750 RPM
	Number of Poles	4	

<i>Dimensions:</i>	Frame Size	Page	Frame Size	Page
	1100	3.36	1400	3.40
	1200	3.37	1500	3.42
	1300	3.38	1600	3.44

50Hz				60Hz				Selection									
Output Speed (RPM)	Output Torque		Service Factor ^[1]		Solid Shaft Overhung Load		Output Speed (RPM)	Output Torque		Service Factor ^[1]		Solid Shaft Overhung Load		Base			Max Hz ^[2]
	in·lbs	(N·m)	SF	AGMA Class	lbs	(N)		in·lbs	(N·m)	SF	AGMA Class	lbs	(N)	Motor Power Code	Frame Size	Ratio	
290	2730	(308)	1.02	I	1120	(5000)	350	2300	(260)	1.00	I	1070	(4760)	15	1634	5	60
207	3820	(431)	1.02	I	1260	(5590)	250	3220	(363)	1.00	I	1180	(5250)	15	1634	7	60
145	5450	(616)	1.02	I	1400	(6230)	175	4590	(519)	1.00	I	1330	(5930)	15	1634	10	60
121	6540	(739)	1.02	I	1490	(6620)	146	5510	(623)	1.00	I	1420	(6330)	15	1634	12	60
96.7	8180	(924)	1.02	I	1560	(6960)	117	6890	(779)	1.00	I	1500	(6670)	15	1634	15	60
72.5	10900	(1230)	1.02	I	1730	(7700)	87.5	9190	(1040)	1.00	I	1650	(7350)	15	1634	20	60

Hyponic®

Selection Tables

Note: [1] Selections with service factor marked with an asterisk (*) should be limited to the identified output torque.

[2] Maximum allowable input speed is 3600rpm unless otherwise noted.

Variable Frequency Drive (VFD) notes (see page 3.8 for Constant Torque Speed Ranges)

All 1HP+ motors require EP suffix in model number and can be used with a VFD, unless noted.

Selection Tables for (AV) Fractional HP, Inverter Ready

Three-Phase

Dimensions:	Frame Size	Page	Frame Size	Page
	1100	3.36	1400	3.40
	1200	3.37	1500	3.42
	1300	3.38	1600	3.44

Frequency	50 Hz	60 Hz
Input Speed	1450 RPM	1750 RPM
Number of Poles	4	

1/8 HP
0.1 kW

Output Speed RPM									Selection			
Output Speed RPM			Output Torque		Service Factor ^[1]		Solid Shaft Overhung Load		Base			VFD ^[2]
6 Hz	60 Hz	120 Hz	in-lbs	(N·m)	SF	AGMA Class	lbs	(N)	Motor Power Code	Frame Size	Ratio	
35.0	350	700	19	(2.16)	2.14	III	132	(588)	01	1120	5	AV
25.0	250	500	27	(3.03)	2.00	III	143	(637)	01	1120	7	AV
17.5	175	350	38	(4.33)	2.00	III	165	(735)	01	1120	10	AV
14.6	146	292	46	(5.19)	2.00	III	176	(785)	01	1120	12	AV
11.7	117	234	57	(6.49)	2.00	III	187	(834)	01	1120	15	AV
8.75	87.5	175	77	(8.65)	2.00	III	209	(932)	01	1120	20	AV
7.00	70.0	140	96	(10.8)	2.00	III	220	(980)	01	1120	25	AV
5.83	58.3	117	115	(13.0)	2.00	III	232	(1030)	01	1120	30	AV
4.38	43.8	87.6	153	(17.3)	1.00	I	254	(1130)	01	1120	40	AV
4.38					2.00	III	353	(1570)	01	1220	40	AV
3.50	35.0	70.0	191	(21.6)	1.00	I	277	(1230)	01	1120	50	AV
3.50					2.00	III	375	(1670)	01	1220	50	AV
2.92	29.2	58.4	230	(26.0)	1.00	I	286	(1270)	01	1120	60	AV
2.92					2.00	III	387	(1720)	01	1220	60	AV
2.19	21.9	43.8	306	(34.6)	1.00	I	398	(1770)	01	1230	80	AV
2.19					2.00	III	661	(2940)	01	1330	80	AV
1.75	17.5	35.0	383	(43.3)	1.00	I	398	(1770)	01	1230	100	AV
1.75					2.00	III	683	(3040)	01	1330	100	AV
1.46	14.6	29.2	459	(51.9)	1.00	I	407	(1810)	01	1230	120	AV
1.46					2.00	III	695	(3090)	01	1330	120	AV
1.17	11.7	23.4	574	(64.9)	1.00	I	407	(1810)	01	1230	150	AV
1.17					2.00	III	695	(3090)	01	1330	150	AV
0.875	8.75	17.5	821	(92.8)	*	-	407	(1810)	01	1230	200	AV
0.875			766	(86.5)	1.74	II	695	(3090)	01	1330	200	AV
0.729	7.29	14.6	868	(98.1)	*	-	407	(1810)	01	1230	240	AV
0.729			919	(104)	1.45	II	695	(3090)	01	1330	240	AV
0.583	5.83	11.7	1150	(130)	1.00	I	695	(3090)	01	1340	300	AV
0.583					2.00	III	980	(4360)	01	1440	300	AV

Hyponic®

Selection
Tables

Note: [1] Selections with service factor marked with an asterisk (*) should be limited to the identified output torque.

[2] Variable Frequency Drive (VFD) notes (see page 3.8 for Constant Torque Speed Ranges)

AV = AF-motor (AV suffix) option required (not required EP motors [1HP+])

Selection Tables for (AV) Fractional HP, Inverter Ready

Three-Phase

1/8 HP 0.1 kW	Frequency	50 Hz	60 Hz
	Input Speed	1450 RPM	1750 RPM
	Number of Poles	4	

<i>Dimensions:</i>	Frame Size	Page	Frame Size	Page
	1100	3.36	1400	3.40
	1200	3.37	1500	3.42
	1300	3.38	1600	3.44

Output Speed RPM									Selection			
Output Speed RPM			Output Torque		Service Factor ^[1]		Solid Shaft Overhung Load		Base			VFD ^[2]
6 Hz	60 Hz	120 Hz	in-lbs	(N·m)	SF	AGMA Class	lbs	(N)	Motor Power Code	Frame Size	Ratio	
0.486	4.86	9.72	1380	(156)	1.00	I	695	(3090)	01	1340	360	AV
0.486					2.00	III	980	(4360)	01	1440	360	AV
0.365	3.65	7.30	1840	(207)	*	-	695	(3090)	01	1340	480	AV
0.365			1840	(208)	1.54	II	980	(4360)	01	1440	480	AV
0.292	2.92	5.84	2300	(260)	1.24	I	980	(4360)	01	1440	600	AV
0.292					2.32	III	1400	(6230)	01	1540	600	AV
0.243	2.43	4.86	2760	(311)	1.03	I	980	(4360)	01	1440	720	AV
0.243					1.93	II	1400	(6230)	01	1540	720	AV
0.194	1.94	3.88	3670	(415)	*	-	980	(4360)	01	1440	900	AV
0.194			3450	(389)	1.54	II	1400	(6230)	01	1540	900	AV
0.146	1.46	2.92	3670	(415)	*	-	980	(4360)	01	1440	1200	AV
0.146			4590	(519)	1.16	I	1400	(6230)	01	1540	1200	AV
0.122	1.22	2.44	3670	(415)	*	-	980	(4360)	01	1440	1440	AV
0.122			6880	(778)	*	-	1400	(6230)	01	1540	1440	AV

Hyponic®

Selection Tables

Note: [1] Selections with service factor marked with an asterisk (*) should be limited to the identified output torque.

[2] Variable Frequency Drive (VFD) notes (see page 3.8 for Constant Torque Speed Ranges)

AV = AF-motor (AV suffix) option required (not required EP motors [1HP+])

Selection Tables for (AV) Fractional HP, Inverter Ready

Three-Phase

Dimensions:	Frame Size	Page	Frame Size	Page
	1100	3.36	1400	3.40
	1200	3.37	1500	3.42
	1300	3.38	1600	3.44

Frequency	50 Hz	60 Hz
Input Speed	1450 RPM	1750 RPM
Number of Poles	4	

1/4 HP
0.2 kW

										Selection		
Output Speed RPM			Output Torque		Service Factor ^[1]		Solid Shaft Overhung Load		Base			VFD ^[2]
6 Hz	60 Hz	120 Hz	in-lbs	(N·m)	SF	AGMA Class	lbs	(N)	Motor Power Code	Frame Size	Ratio	
35.0	350	700	38	(4.33)	1.00	I	132	(588)	02	1120	5	AV
35.0					2.00	III	187	(834)	02	1220	5	AV
25.0	250	500	54	(6.06)	1.00	I	143	(637)	02	1120	7	AV
25.0					2.00	III	209	(932)	02	1220	7	AV
17.5	175	350	77	(8.65)	1.00	I	165	(735)	02	1120	10	AV
17.5					2.00	III	232	(1030)	02	1220	10	AV
14.6	146	292	92	(10.4)	1.00	I	176	(785)	02	1120	12	AV
14.6					2.00	III	243	(1080)	02	1220	12	AV
11.7	117	234	115	(13.0)	1.00	I	187	(834)	02	1120	15	AV
11.7					2.00	III	265	(1180)	02	1220	15	AV
8.75	87.5	175	153	(17.3)	1.00	I	209	(932)	02	1120	20	AV
8.75					2.00	III	297	(1320)	02	1220	20	AV
7.00	70.0	140	191	(21.6)	1.00	I	220	(980)	02	1120	25	AV
7.00					2.00	III	308	(1370)	02	1220	25	AV
5.83	58.3	117	230	(26.0)	1.00	I	232	(1030)	02	1120	30	AV
5.83					2.00	III	330	(1470)	02	1220	30	AV
4.38	43.8	87.6	306	(34.6)	1.00	I	353	(1570)	02	1220	40	AV
4.38					2.00	III	573	(2550)	02	1320	40	AV
3.50	35.0	70.0	383	(43.3)	1.00	I	375	(1670)	02	1220	50	AV
3.50					2.00	III	618	(2750)	02	1320	50	AV
2.92	29.2	58.4	459	(51.9)	1.00	I	387	(1720)	02	1220	60	AV
2.92					2.00	III	638	(2840)	02	1320	60	AV
2.19	21.9	43.8	613	(69.2)	1.00	I	661	(2940)	02	1330	80	AV
2.19					2.00	III	960	(4270)	02	1430	80	AV
1.75	17.5	35.0	766	(86.5)	1.00	I	683	(3040)	02	1330	100	AV
1.75					2.00	III	980	(4360)	02	1430	100	AV
1.46	14.6	29.2	919	(104)	1.00	I	695	(3090)	02	1330	120	AV
1.46					2.00	III	980	(4360)	02	1430	120	AV
1.17	11.7	23.4	1150	(130)	1.00	I	695	(3090)	02	1330	150	AV

Note: [1] Selections with service factor marked with an asterisk (*) should be limited to the identified output torque.

[2] Variable Frequency Drive (VFD) notes (see page 3.8 for Constant Torque Speed Ranges)

AV = AF-motor (AV suffix) option required (not required EP motors [1HP+])

Selection Tables for (AV) Fractional HP, Inverter Ready

Three-Phase

1/4 HP 0.2 kW	Frequency	50 Hz	60 Hz
	Input Speed	1450 RPM	1750 RPM
	Number of Poles	4	

<i>Dimensions:</i>	Frame Size	Page	Frame Size	Page
	1100	3.36	1400	3.40
	1200	3.37	1500	3.42
	1300	3.38	1600	3.44

										Selection		
Output Speed RPM			Output Torque		Service Factor ^[1]		Solid Shaft Overhung Load		Base			VFD ^[2]
6 Hz	60 Hz	120 Hz	in-lbs	(N·m)	SF	AGMA Class	lbs	(N)	Motor Power Code	Frame Size	Ratio	
1.17					2.00	III	980	(4360)	02	1430	150	AV
0.875	8.75	17.5	1640	(186)	*	-	695	(3090)	02	1330	200	AV
0.875			1530	(173)	1.74	II	980	(4360)	02	1430	200	AV
0.729	7.29	14.6	1730	(195)	*	-	695	(3090)	02	1330	240	AV
0.729			1840	(208)	1.45	II	980	(4360)	02	1430	240	AV
0.583	5.83	11.7	2300	(260)	1.00	I	980	(4360)	02	1440	300	AV
0.583					2.00	III	1400	(6230)	02	1540	300	AV
0.486	4.86	9.72	2760	(311)	1.00	I	980	(4360)	02	1440	360	AV
0.486					1.93	II	1400	(6230)	02	1540	360	AV
0.365	3.65	7.30	3670	(415)	*	-	980	(4360)	02	1440	480	AV
0.365			3680	(415)	1.45	II	1400	(6230)	02	1540	480	AV
0.292	2.92	5.84	4590	(519)	1.16	I	1400	(6230)	02	1540	600	AV
0.292					2.34	III	2210	(9810)	02	1640	600	AV
0.243	2.43	4.86	6880	(778)	*	-	1400	(6230)	02	1540	720	AV
0.243			5190	(586)	1.95	II	2210	(9810)	02	1640	720	AV
0.194	1.94	3.88	6880	(778)	*	-	1400	(6230)	02	1540	900	AV
0.194			6490	(733)	1.56	II	2210	(9810)	02	1640	900	AV
0.146	1.46	2.92	6880	(778)	*	-	1400	(6230)	02	1540	1200	AV
0.146			8650	(977)	1.17	I	2210	(9810)	02	1640	1200	AV
0.122	1.22	2.44	6880	(778)	*	-	1400	(6230)	02	1540	1440	AV
0.122			13100	(1480)	*	-	2210	(9810)	02	1640	1440	AV

Hyponic®

Selection Tables

Note: [1] Selections with service factor marked with an asterisk (*) should be limited to the identified output torque.

[2] Variable Frequency Drive (VFD) notes (see page 3.8 for Constant Torque Speed Ranges)

AV = AF-motor (AV suffix) option required (not required EP motors [1HP+])

Selection Tables for (AV) Fractional HP, Inverter Ready

Three-Phase

Dimensions:	Frame Size	Page	Frame Size	Page
	1100	3.36	1400	3.40
	1200	3.37	1500	3.42
	1300	3.38	1600	3.44

Frequency	50 Hz	60 Hz
Input Speed	1450 RPM	1750 RPM
Number of Poles	4	

1/3 HP
0.25 kW

Output									Selection			
Output Speed RPM			Output Torque		Service Factor ^[1]		Solid Shaft Overhung Load		Base			VFD ^[2]
6 Hz	60 Hz	120 Hz	in-lbs	(N·m)	SF	AGMA Class	lbs	(N)	Motor Power Code	Frame Size	Ratio	
35.0	350	700	51	(5.77)	1.60	II	187	(834)	03	1220	5	AV
25.0	250	500	72	(8.07)	1.60	II	209	(932)	03	1220	7	AV
17.5	175	350	102	(11.5)	1.60	II	232	(1030)	03	1220	10	AV
14.6	146	292	123	(13.8)	1.60	II	243	(1080)	03	1220	12	AV
11.7	117	234	153	(17.3)	1.60	II	265	(1180)	03	1220	15	AV
8.75	87.5	175	204	(23.1)	1.60	II	297	(1320)	03	1220	20	AV
7.00	70.0	140	255	(28.8)	1.60	II	308	(1370)	03	1220	25	AV
5.83	58.3	117	306	(34.6)	1.60	II	330	(1470)	03	1220	30	AV
4.38	43.8	87.6	408	(46.1)	1.60	II	573	(2550)	03	1320	40	AV
3.50	35.0	70.0	510	(57.7)	1.60	II	618	(2750)	03	1320	50	AV
2.92	29.2	58.4	613	(69.2)	1.60	II	638	(2840)	03	1320	60	AV
2.19	21.9	43.8	817	(92.3)	1.60	II	960	(4270)	03	1430	80	AV
1.75	17.5	35.0	1020	(115)	1.60	II	980	(4360)	03	1430	100	AV
1.46	14.6	29.2	1230	(138)	1.60	II	980	(4360)	03	1430	120	AV
1.17	11.7	23.4	1530	(173)	1.60	II	980	(4360)	03	1430	150	AV
0.875	8.75	17.5	2040	(231)	1.39	I	980	(4360)	03	1430	200	AV
0.729	7.29	14.6	2450	(277)	1.16	I	980	(4360)	03	1430	240	AV
0.583	5.83	11.7	3060	(346)	1.60	II	1400	(6230)	03	1540	300	AV
0.486	4.86	9.72	3680	(415)	1.54	II	1400	(6230)	03	1540	360	AV
0.365	3.65	7.30	4900	(554)	1.16	I	1400	(6230)	03	1540	480	AV
0.292	2.92	5.84	5770	(651)	1.87	II	2210	(9810)	03	1640	600	AV
0.243	2.43	4.86	6920	(782)	1.56	II	2210	(9810)	03	1640	720	AV
0.194	1.94	3.88	8650	(977)	1.25	I	2210	(9810)	03	1640	900	AV
0.146	1.46	2.92	13100	(1480)	*	-	2210	(9810)	03	1640	1200	AV
0.122	1.22	2.44	13100	(1480)	*	-	2210	(9810)	03	1640	1440	AV

Note: [1] Selections with service factor marked with an asterisk (*) should be limited to the identified output torque.

[2] Variable Frequency Drive (VFD) notes (see page 3.8 for Constant Torque Speed Ranges)

AV = AF-motor (AV suffix) option required (not required EP motors [1HP+])

Selection Tables for (AV) Fractional HP, Inverter Ready

Three-Phase

1/2 HP 0.4 kW	Frequency	50 Hz	60 Hz
	Input Speed	1450 RPM	1750 RPM
	Number of Poles	4	

<i>Dimensions:</i>	Frame Size	Page	Frame Size	Page
	1100	3.36	1400	3.40
	1200	3.37	1500	3.42
	1300	3.38	1600	3.44

										Selection		
Output Speed RPM			Output Torque		Service Factor ^[1]		Solid Shaft Overhung Load		Base			VFD ^[2]
6 Hz	60 Hz	120 Hz	in-lbs	(N·m)	SF	AGMA Class	lbs	(N)	Motor Power Code	Frame Size	Ratio	
35.0	350	700	77	(8.65)	2.00	III	308	(1370)	05	1320	5	AV
25.0	250	500	107	(12.1)	2.00	III	353	(1570)	05	1320	7	AV
17.5	175	350	153	(17.3)	2.00	III	387	(1720)	05	1320	10	AV
14.6	146	292	184	(20.8)	2.00	III	407	(1810)	05	1320	12	AV
11.7	117	234	230	(26.0)	2.00	III	441	(1960)	05	1320	15	AV
8.75	87.5	175	306	(34.6)	2.00	III	486	(2160)	05	1320	20	AV
7.00	70.0	140	383	(43.3)	2.00	III	508	(2260)	05	1320	25	AV
5.83	58.3	117	459	(51.9)	2.00	III	528	(2350)	05	1320	30	AV
4.38	43.8	87.6	613	(69.2)	2.00	III	859	(3820)	05	1420	40	AV
3.50	35.0	70.0	766	(86.5)	2.00	III	904	(4020)	05	1420	50	AV
2.92	29.2	58.4	919	(104)	2.00	III	937	(4170)	05	1420	60	AV
2.19	21.9	43.8	1230	(138)	2.00	III	1380	(6130)	05	1530	80	AV
1.75	17.5	35.0	1530	(173)	2.00	III	1400	(6230)	05	1530	100	AV
1.46	14.6	29.2	1840	(208)	2.00	III	1400	(6230)	05	1530	120	AV
1.17	11.7	23.4	2300	(260)	2.00	III	1400	(6230)	05	1530	150	AV
0.875	8.75	17.5	3060	(346)	1.63	II	1400	(6230)	05	1530	200	AV
0.729	7.29	14.6	3680	(415)	1.36	I	1400	(6230)	05	1530	240	AV
0.583	5.83	11.7	4320	(489)	2.00	III	2210	(9810)	05	1640	300	AV
0.486	4.86	9.72	5190	(586)	1.95	II	2210	(9810)	05	1640	360	AV
0.365	3.65	7.30	6920	(782)	1.46	II	2210	(9810)	05	1640	480	AV
0.292	2.92	5.84	8650	(977)	1.17	I	2210	(9810)	05	1640	600	AV
0.243	2.43	4.86	13100	(1480)	*	-	2210	(9810)	05	1640	720	AV
0.194	1.94	3.88	13100	(1480)	*	-	2210	(9810)	05	1640	900	AV
0.146	1.46	2.92	13100	(1480)	*	-	2210	(9810)	05	1640	1200	AV
0.122	1.22	2.44	13100	(1480)	*	-	2210	(9810)	05	1640	1440	AV

Hyponic®

Selection Tables

Note: [1] Selections with service factor marked with an asterisk (*) should be limited to the identified output torque.

[2] Variable Frequency Drive (VFD) notes (see page 3.8 for Constant Torque Speed Ranges)

AV = AF-motor (AV suffix) option required (not required EP motors [1HP+])

Selection Tables for (AV) Fractional HP, Inverter Ready

Three-Phase

Dimensions:	Frame Size	Page	Frame Size	Page
	1100	3.36	1400	3.40
	1200	3.37	1500	3.42
	1300	3.38	1600	3.44

Frequency	50 Hz	60 Hz
Input Speed	1450 RPM	1750 RPM
Number of Poles	4	

3/4 HP
0.55 kW

Output									Selection			
Output Speed RPM			Output Torque		Service Factor ^[1]		Solid Shaft Overhung Load		Base			VFD ^[2]
6 Hz	60 Hz	120 Hz	in-lbs	(N·m)	SF	AGMA Class	lbs	(N)	Motor Power Code	Frame Size	Ratio	
35.0	350	700	115	(13.0)	2.80	III	463	(2060)	08	1420	5	AV
25.0	250	500	161	(18.2)	2.80	III	517	(2300)	08	1420	7	AV
17.5	175	350	230	(26.0)	2.80	III	585	(2600)	08	1420	10	AV
14.6	146	292	276	(31.1)	2.80	III	618	(2750)	08	1420	12	AV
11.7	117	234	345	(38.9)	2.80	III	661	(2940)	08	1420	15	AV
8.75	87.5	175	459	(51.9)	2.80	III	717	(3190)	08	1420	20	AV
7.00	70.0	140	574	(64.9)	2.80	III	760	(3380)	08	1420	25	AV
5.83	58.3	117	689	(77.9)	2.80	III	805	(3580)	08	1420	30	AV
4.38	43.8	87.6	919	(104)	2.80	III	1250	(5540)	08	1520	40	AV
3.50	35.0	70.0	1150	(130)	2.80	III	1310	(5830)	08	1520	50	AV
2.92	29.2	58.4	1380	(156)	2.80	III	1360	(6030)	08	1520	60	AV
2.19	21.9	43.8	1840	(208)	2.80	III	1380	(6130)	08	1531	80	AV
1.75	17.5	35.0	2300	(260)	4.07	III	2210	(9810)	08	1630	100	AV
1.46	14.6	29.2	2760	(311)	4.07	III	2210	(9810)	08	1630	120	AV
1.17	11.7	23.4	3450	(389)	3.21	III	2210	(9810)	08	1631	150	AV
0.875	8.75	17.5	4590	(519)	2.41	III	2210	(9810)	08	1631	200	AV
0.729	7.29	14.6	5510	(623)	2.00	III	2210	(9810)	08	1631	240	AV

Hyponic®

Selection
Tables

Note: [1] Selections with service factor marked with an asterisk (*) should be limited to the identified output torque.

[2] Variable Frequency Drive (VFD) notes (see page 3.8 for Constant Torque Speed Ranges)

AV = AF-motor (AV suffix) option required (not required EP motors [1HP+])

Dimensions

Frame Size 1100 RNYM-1120Y

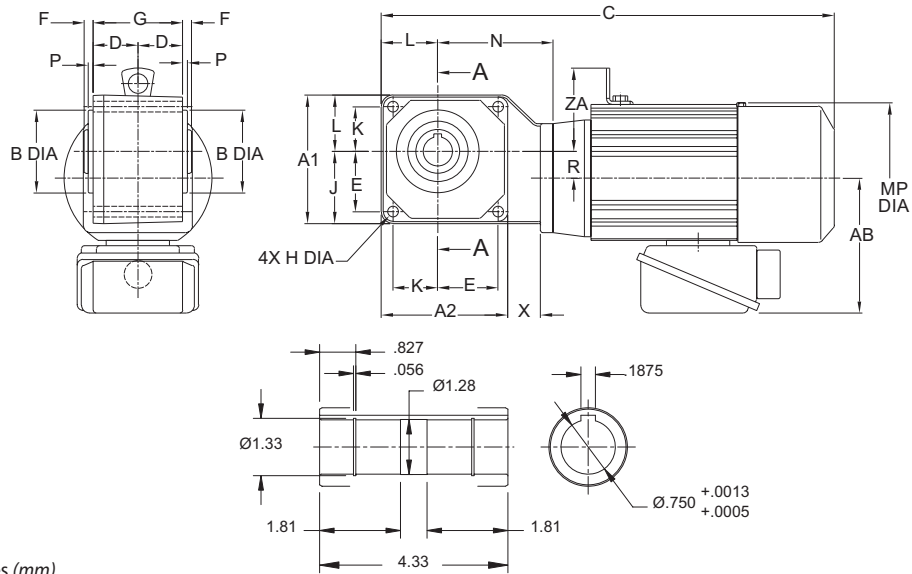

All dimensions are in inches (mm).

Hyponic®

Dimensions

Model	A1	A2	B min	B max	D	E	F	G	H	J	K	L	N	P	R	X
1120	3.54 (90)	3.46 (88)	2.0460 (51.97)	2.0472 (52)	1.30 (33)	1.65 (42)	0.31 (8)	2.6 (66)	0.26 (6.6)	1.97 (50)	1.26 (32)	1.57 (40)	3.23 (82)	0.24 (6)	0.79 (20)	0.87 (22)

Model	HP x P (kW x P)	AB	ZA	Without Brake			With Brake		
				C	MP	Weight lb (kg)	C	MP	Weight lb (kg)
RNYM01-1120Y (-B)-5~60	1/8 x 4 (0.1 x 4)	4.63 (118)	-	10.55 (268)	4.69 (119)	14 (7)	11.93 (303)	4.88 (124)	17 (8)
RNYM02-1120Y (-B)-5~30	1/4 x 4 (0.2 x 4)			12.20 (310)	4.88 (124)	16 (8)	13.46 (342)		19 (9)
RNYM01-1120Y-AV (-B)-5~60	1/8 x 4 (0.1 x 4)			11.54 (293)		19 (9)	12.80 (325)		22 (10)
RNYM02-1120Y-AV (-B)-5~30	1/4 x 4 (0.2 x 4)								

Dimensions

Frame Size 1200 RNYM-1220/30Y

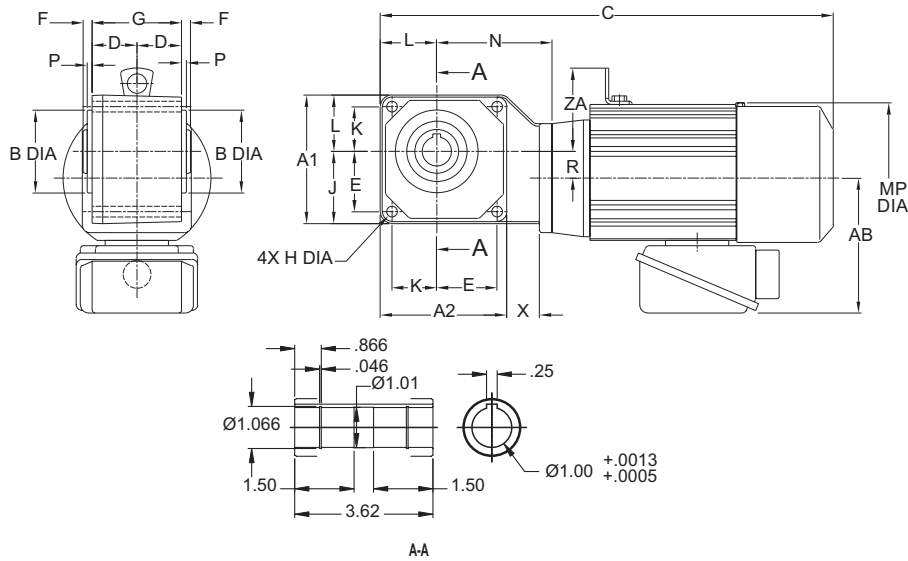

All dimensions are in inches (mm).

Model	A1	A2	B min	B max	D	E	F	G	H	J	K	L	N	P	R	X
1220Y	4.53 (115)	4.45 (113)	3.0697 (77.97)	3.0709 (78)	1.46 (37)	2.24 (57)	0.35 (9)	2.91 (74)	0.35 (9)	2.60 (66)	1.57 (40)	1.93 (49)	3.78 (96)	0.20 (5)	1.10 (28)	0.79 (20)
1230Y	5.00 (127)	5.00 (127)	3.070 (77.97)	3.071 (78)	1.61 (41)	2.56 (65)		3.23 (82)		2.99 (76)		2.01 (51)			3.74 (95)	0.51 (13)

Hyponic®

Dimensions

Model	HP x P (kW x P)	AB	ZA	Without Brake			With Brake		
				C	MP	Weight	C	MP	Weight
RNYM01-1220Y(-B)-40~60	1/8 X 4 (0.1 X 4)	4.63 (118)	-	11.46 (291)	4.88 (124)	17 (8)	12.83 (326)	4.88 (124)	20 (9)
RNYM02-1220Y(-B)-5~60	1/4 X 4 (0.2 X 4)			13.11 (333)		19 (9)	14.37 (365)		22 (10)
RNYM03-1220Y(-B)-5~30	1/3 X 4 (0.25 X 4)			13.90 (353)		22 (10)	15.16 (385)		25 (12)
RNYM05-1220Y(-B)-5~30	1/2 X 4 (0.4 X 4)			13.90 (353)		22 (10)	15.16 (385)		25 (12)
RNYM01-1230Y(-B)-80~240	1/8 X 4 (0.1 X 4)			11.50 (292)		17 (8)	12.87 (327)		20 (9)
RNYM01-1220Y-AV(-B)-40~60	1/4 X 4 (0.2 X 4)			13.11 (333)		19 (9)	14.37 (365)		22 (10)
RNYM02-1220Y-AV(-B)-5~60	1/3 X 4 (0.25 X 4)			13.90 (353)		22 (10)	15.16 (385)		25 (12)
RNYM01-1230Y-AV(-B)-80~240	1/8 X 4 (0.1 X 4)			13.15 (334)		19 (9)	14.41 (366)		22 (10)

Dimensions

Frame Size 1300 RNYM-1320/30/40Y

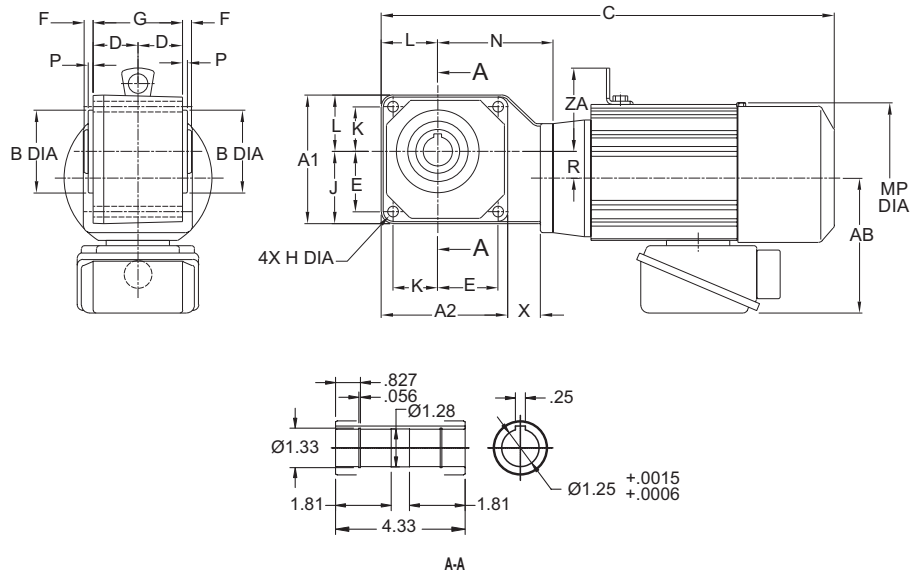

All dimensions are in inches (mm).

Gearmotors

Dimensions

Model	A1	A2	B min	B max	D	E	F	G	H	J	K	L	N	P	R	X
1320Y	5.20 (132)	5.12 (130)	3.345 (84.965)	3.346 (85)	1.81 (46)	2.44 (62)	0.35 (9)	3.62 (92)	0.43 (11)	2.91 (74)	1.81 (46)	2.28 (58)	4.68 (119)	0.20 (5)	1.08 (27.5)	1.34 (34)
1330Y	5.98 (152)	5.98 (152)		3.346 (85.000)		3.11 (79)				3.62 (92)	3.62 (92)	1.85 (47)	2.36 (60)		4.23 (108)	0.43 (11)
1340Y															5.16 (131)	0.35 (9)

Model	HP x P (kW x P)	AB	ZA	Without Brake			With Brake		
				C	MP	Weight lb (kg)	C	MP	Weight lb (kg)
RNYM05-1320Y (-B)-5~60	1/2 x 4 (0.4 x 4)	4.63 (118)	-	15.00 (381)	4.88 (124)	26 (12)	16.26 (413)	4.88 (124)	29 (14)
RNYM08-1320Y (-B)-5~30	3/4 x 4 (0.55 x 4)	5.67 (144)	3.33 (85)	16.65 (423)	5.94 (151)	28 (13)	18.35 (466)	5.94 (151)	34 (16)
RNYM05-1320Y-AV (-B)-5~30	1/2 x 4 (0.4 x 4)	5.67 (144)				33 (15)			39 (18)
RNYM1-1320Y-EP (-B)-5~30	1 x 4 (0.75 x 4)	5.98 (152)				43 (20)			53 (24)
RNYM02-1320Y (-B)-40~60	1/4 x 4 (0.2 x 4)	4.63 (118)	-	14.21 (361)	4.88 (124)	23 (11)	16.26 (413)	4.88 (124)	26 (12)
RNYM03-1320Y (-B)-40~60	1/3 x 4 (0.25 x 4)					25 (12)			28 (13)
RNYM02-1320Y-AV (-B)-40~60	1/4 x 4 (0.2 x 4)					20 (9)			23 (11)
RNYM03-1320Y-AV (-B)-40~60	1/3 x 4 (0.25 x 4)					22 (10)			25 (12)
RNYM01-1330Y (-B)-80~240	1/8 x 4 (0.1 x 4)					12.36 (314)			13.74 (349)
RNYM02-1330Y (-B)-80~240	1/4 x 4 (0.2 x 4)	14.02 (356)	15.28 (388)	25 (12)					

Dimensions

Frame Size 1300 RNYM-1320/30/40Y (cont.)

All dimensions are in inches (*mm*).

Model	HP x P (kW x P)	AB	ZA	Without Brake			With Brake		
				C	MP	Weight lb (kg)	C	MP	Weight lb (kg)
RNYM01-1330Y-AV (-B)-5~30	1/8 x 4 (0.1 x 4)	4.63 (118)	-	14.02 (356)	4.88 (124)	22 (10)	15.28 (388)	4.88 (124)	25 (12)
RNYM02-1330Y-AV (-B)-80~240	1/4 x 4 (0.2 x 4)			13.35 (339)		25 (12)			14.61 (371)
RNYM01-1340Y (-B)-80~240	1/8 x 4 (0.1 x 4)			13.27 (337)	4.69 (119)	22 (10)	14.65 (372)	25 (12)	
RNYM01-1340Y-AV (-B)-300~480	1/8 x 4 (0.1 x 4)			13.46 (342)	4.88 (124)	24 (11)	14.72 (374)	27 (13)	

Hyponic®

Dimensions

Dimensions

Frame Size 1400 RNYM-1420/30/40Y

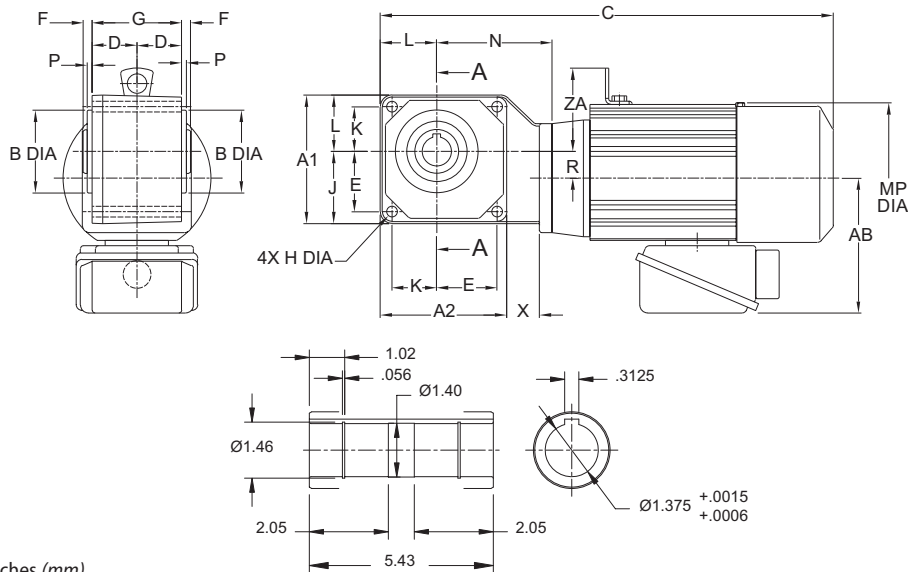

All dimensions are in inches (mm).

Hyponic®

Dimensions

Model	A1	A2	B min	B max	D	E	F	G	H	J	K	L	N	P	R	X
1420Y	6.22 (158)	6.10 (155)	3.739 (94.965)	3.740 (95.000)	2.32 (59)	2.95 (75)	0.39 (10)	4.65 (118)	0.55 (14)	3.46 (88)	2.24 (57)	2.76 (70)	5.75 (146)	0.20 (5)	0.79 (20)	1.69 (43)
1430Y	7.01 (178)	7.01 (178)				3.62 (92)				4.25 (108)	2.13 (54)		5.12 (130)		0.55 (14)	0.43 (11)
1440Y													6.42 (163)		0.43 (11)	1.73 (44)

Model	HP x P (kW x P)	AB	ZA	Without Brake			With Brake		
				C	MP	Weight lb (kg)	C	MP	Weight lb (kg)
RNYM08-1420Y-AV (-B)-5~30	3/4 x 4 (0.55 x 4)	5.86 (149)	3.82 (97)	19.84 (504)	6.30 (160)	49 (22)	22.28 (566)	6.30 (160)	4.53 (115)
RNYM1-1420Y-EP (-B)-5~60	1 x 4 (0.75 x 4)	5.98 (152)	3.62 (92)	20.28 (515)	6.22 (158)	53 (24)	22.78 (579)	6.22 (158)	4.80 (122)
RNYM1H-1420Y-EP (-B)-5~30	1.5 x 4 (1.1 x 4)	6.16 (156)	3.82 (97)	21.34 (542)	6.57 (167)	63 (29)	24.07 (612)	6.57 (167)	5.04 (128)
RNYM2-1420Y-EP (-B)-5~30	2 x 4 (1.5 x 4)								
RNYM05-1420Y (-B)-40~60	1/2 x 4 (0.4 x 4)	4.63 (118)	-	16.24 (413)	4.88 (124)	34 (16)	17.50 (445)	4.88 (124)	2.40 (61)
RNYM08-1420Y (-B)-40~60	3/4 x 4 (0.55 x 4)	5.67 (144)	3.62 (92)	18.66 (474)	5.94 (151)	37 (17)	20.35 (517)	5.94 (151)	3.66 (93)
RNYM05-1420Y-AV (-B)-40~60	1/2 x 4 (0.4 x 4)					42 (19)			
RNYM02-1430Y (-B)-80~240	1/4 x 4 (0.2 x 4)	4.63 (118)	-	15.12 (384)	4.88 (124)	31 (14)	16.38 (416)	4.88 (124)	2.40 (61)
RNYM03-1430Y (-B)-80~240	1/3 x 4 (0.25 x 4)			15.91 (404)		33 (15)			

Dimensions

Frame Size 1400 RNYM-1420/30/40Y (cont.)

All dimensions are in inches (mm).

Model	HP x P (kW x P)	AB	ZA	Without Brake			With Brake		
				C	MP	Weight lb (kg)	C	MP	Weight lb (kg)
RNYM02-1430Y-AV (-B)-80~240	1/4 x 4 (0.2 x 4)	4.63 (118)	-	15.12 (384)	4.88 (124)	34 (16)	17.17 (436)	4.88 (124)	38 (17)
RNYM03-1430Y-AV (-B)-80~240	1/3 x 4 (0.25 x 4)			15.91 (404)		35 (16)			
RNYM05-1430Y (-B)-80~240	1/2 x 4 (0.4 x 4)			14.92 (379)	4.69 (119)	32 (15)	16.30 (414)	35 (16)	
RNYM01-1440Y (-B)-300~1440	1/8 x 4 (0.1 x 4)			16.57 (421)	4.88 (124)	34 (16)	17.83 (453)	37 (17)	
RNYM02-1440Y (-B)-300~1440	1/4 x 4 (0.2 x 4)			15.91 (404)		37 (17)	17.17 (436)	40 (18)	
RNYM01-1440Y-AV (-B)-300~1440	1/8 x 4 (0.1 x 4)								
RNYM02-1440Y-AV (-B)-300~480	1/4 x 4 (0.2 x 4)								

Hyponic®

Dimensions

Dimensions

Frame Size 1500 RNYM-1520/21/22/30/31/40Y

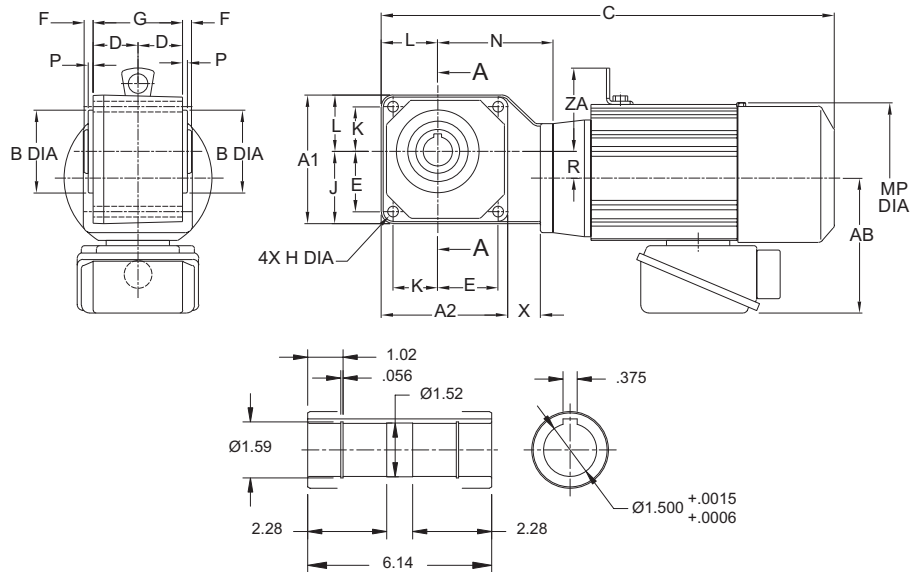

All dimensions are in inches (mm).

Hyponic®

Dimensions

Model	A1	A2	B min	B max	D	E	F	G	H	J	K	L	N	P	R	X
1520/21/22	7.01 (178)	6.89 (175)	4.32930 (109.965)	4.3307 (110)	2.68 (68)	3.15 (80)	0.39 (10)	5.35 (136)	0.55 (14)	3.7 (94)	2.76 (70)	3.31 (84)	7.01 (178)	0.20 (5)	1.1 (28)	2.68 (68)
1530/31	8.39 (213)	8.39 (213)				4.29 (109)			0.71 (18)	5.08 (129)	2.52 (64)		6.18 (157)		0.67 (17)	0.37 (10)
1540													7.76 (197)		0.55 (14)	2.13 (54)

Model	HP x P (kW x P)	AB	ZA	Without Brake			With Brake		
				C	MP	Weight lb (kg)	C	MP	Weight lb (kg)
RNYM1-1520Y-EP(-B)-40~60	1 X 4 (0.75 X 4)	5.98 (152)	3.31 (84)	21.46 (545)	6.22 (158)	69 (31)	23.96 (609)	6.22 (158)	78 (36)
RNYM1H-1520Y-EP(-B)-40~60	1.5 X 4 (1.1 X 4)	6.16 (156)	3.5 (89)	22.48 (571)	6.57 (167)	79 (36)	25.22 (641)	6.57 (167)	91 (41)
RNYM2-1520Y-EP(-B)-5~60	2 X 4 (1.5 X 4)					80 (36)			91 (42)
RNYM3-1520Y-EP(-B)-5~30	3 X 4 (2.2 X 4)	6.71 (170)	3.82 (97)	23.33 (593)	7.24 (184)	107 (49)	26.40 (671)	7.24 (184)	123 (56)
RNYM3-1521Y-EP(-B)-5~25						108 (49)			124 (57)
RNYM5-1521Y-EP(-B)-5~25	5 X 4 (3.7 X 4)	7.34 (186)	4.92 (125)	24.69 (627)	8.74 (222)	132 (60)	28.25 (718)	8.74 (222)	156 (71)
RNYM5-1522Y-EP(-B)-5~15						133 (60)			184 (84)
RNYM8-1522Y-EP(-B)-5~15						160 (73)			184 (84)
RNYM05-1530Y(-B)-80~240	1/2 X 4 (0.4 X 4)	4.63 (118)	-	17.22 (438)	4.88 (124)	50 (23)	18.48 (470)	4.88 (124)	54 (25)
RNYM08-1530Y(-B)-80~240	3/4 X 4 (0.55 X 4)	5.67 (144)	3.74 (95)	19.65 (499)	5.94 (151)	54 (25)	21.34 (542)	5.94 (151)	60 (27)

Dimensions

Frame Size 1500 RNYM-1520/21/22/30/31/40Y (cont.)

All dimensions are in inches (mm).

Model	HP x P (kW x P)	AB	ZA	Without Brake			With Brake			
				C	MP	Weight lb (kg)	C	MP	Weight lb (kg)	
RNYM1-1530Y-EP(-B)-80~240	1 X 4 (0.75 X 4)	5.98 (152)	3.74 (95)	21.26 (540)	6.22 (158)	69 (31)	6.22 (158)	6.22 (158)	79 (36)	
RNYM1-1531Y-EP(-B)-80						68 (31)			78 (36)	
RNYM1H-1531Y-EP(-B)-80	1.5 X 4 (1.1 X 4)	6.16 (156)	3.94 (100)	22.32 (567)	6.57 (167)	78 (36)	25.06 (637)	6.57 (167)	90 (41)	
RNYM2-1531Y-EP(-B)-40~80	2 X 4 (1.5 X 4)									
RNYM3-1531Y-EP(-B)-40~80	3 X 4 (2.2 X 4)	6.71 (170)	4.25 (108)	22.50 (572)	7.24 (184)	97 (44)	25.57 (650)	7.24 (184)	114 (52)	
RNYM02-1540Y(-B)-300~1440	1/4 X 4 (0.2 X 4)	4.63 (118)	-	18.31 (465)	4.88 (124)	51 (23)	19.57 (497)	4.88 (124)	54 (25)	
RNYM03-1540Y(-B)-300~1440	1/3 X 4 (0.25 X 4)			19.09 (485)		54 (25)			20.35 (517)	57 (26)
RNYM05-1540Y(-B)-300~1440	1/2 X 4 (0.4 X 4)									
RNYM08-1520Y-AV(-B)-40~60	3/4 X 4 (0.55 X 4)	5.86 (149)	3.50 (89)	21.02 (534)	6.30 (160)	64 (30)	23.46 (596)	6.30 (160)	75 (34)	
RNYM05-1530Y-AV(-B)-80~240	1/2 X 4 (0.4 X 4)	5.67 (144)	3.74 (95)	19.65 (499)	5.94 (151)	58 (27)	21.34 (542)	5.94 (151)	64 (29)	
RNYM08-1531Y-AV(-B)-80	3/4 X 4 (0.55 X 4)	5.86 (149)	3.94 (100)	20.83 (529)	6.30 (160)	64 (29)	23.27 (591)	6.30 (160)	75 (344)	
RNYM01-1540Y-AV(-B)-600~1440	1/8 X 4 (0.1 X 4)	4.63 (118)	-	18.31 (465)	4.88 (124)	51 (23)	19.57 (497)	4.88 (124)	54 (25)	
RNYM02-1540Y-AV(-B)-300~1440	1/4 X 4 (0.2 X 4)			19.09 (485)		54 (25)			20.35 (517)	57 (26)
RNYM03-1540Y-AV(-B)-300~480	1/3 X 4 (0.25 X 4)									

Hyponic®

Dimensions

Dimensions

Frame Size 1600 RNYM-1630/31/32/33/40Y

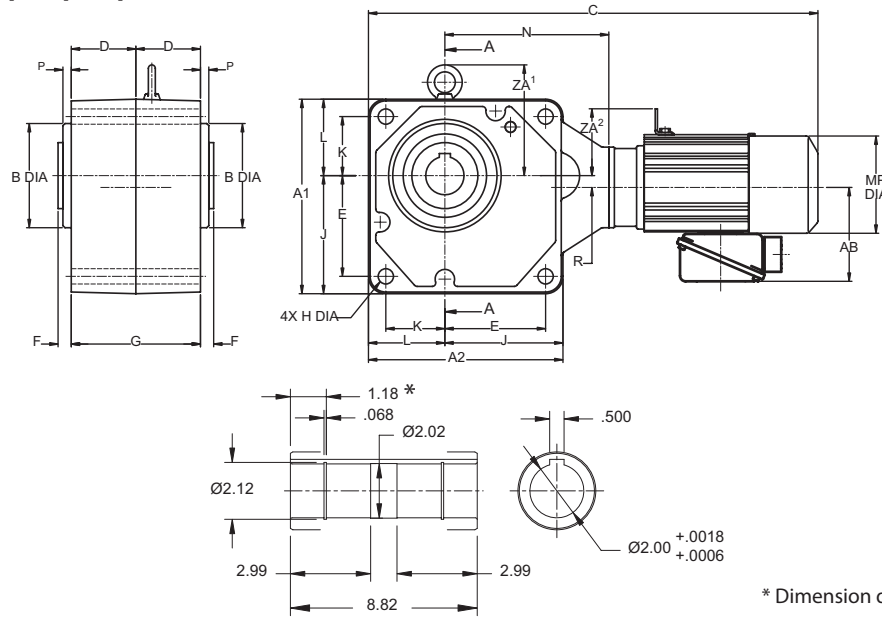

* Dimension depends on the bore size.

All dimensions are in inches (mm).

Hyponic®

Dimensions

Model	A1	A2	B min	B max	D	E	F	G	H	J	K	L	N	P	R	ZA'
1630/31/32/33Y	11 (280)	11 (280)	5.9039 (149.960)	5.9055 (150)	3.66 (93)	5.71 (145)	0.75 (19)	7.32 (186)	0.87 (22)	6.69 (170)	3.35 (85)	4.33 (110)	8.37 (213)	0.5 (12)	1.06 (27)	6.26 (159)
1640Y													9.29 (236)		0.67 (17)	

Model	HP x P (kW x P)	AB	ZA	Without Brake			With Brake		
				C	MP	Weight lb (kg)	C	MP	Weight lb (kg)
RNYM1-1630Y-EP(-B)-100~120	1 X 4 (0.75 X 4)	5.98 (152)	3.35 (85)	23.76 (604)	6.22 (158)	151 (55)	26.26 (667)	6.22 (158)	131 (60)
RNYM1H-1630Y-EP(-B)-100~120	1.5 X 4 (1.1 X 4)	6.16 (156)	3.54 (90)	25.26 (642)	6.57 (167)	134 (61)	27.99 (711)	6.57 (167)	145 (66)
RNYM2-1630Y-EP(-B)-80~120	2 X 4 (1.5 X 4)								
RNYM3-1630Y-EP(-B)-80~120	3 X 4 (2.2 X 4)	6.71 (170)	3.86 (98)	25.75 (654)	7.24 (184)	149 (68)	28.82 (732)	7.24 (184)	166 (76)
RNYM1-1631Y-EP(-B)-150~240	1 X 4 (0.75 X 4)	5.98 (152)	3.35 (85)	24.47 (622)	6.22 (158)	116 (53)	26.97 (685)	6.22 (158)	126 (57)
RNYM1H-1631Y-EP(-B)-200~240	1.5 X 4 (1.1 X 4)	6.16 (156)	3.54 (90)	25.26 (642)	6.57 (167)	126 (58)	27.99 (711)	6.57 (167)	138 (63)
RNYM2-1631Y-EP(-B)-150~240	2 X 4 (1.5 X 4)								
RNYM3-1631Y-EP(-B)-150~240	3 X 4 (2.2 X 4)	6.71 (170)	3.86 (98)	7.24 (184)	136 (62)	136 (62)	28.82 (732)	136.00 (62)	153 (70)
RNYM3-1632Y-EP(-B)-30~60				25.87 (657)	7.24 (184)	152 (69)	28.94 (735)	7.24 (184)	169 (77)

Dimensions

Frame Size 1600 RNYM-1630/31/33/40Y (cont.)

All dimensions are in inches (mm).

Model	HP x P (kW x P)	AB	ZA	Without Brake			With Brake		
				C	MP	Weight lb (kg)	C	MP	Weight lb (kg)
RNYM5-1632Y-EP(-B)-30~60	5 X 4 (3.7 X 4)	7.34 (186)	4.96 (126)	27.11 (689)	8.74 (222)	181 (82)	30.67 (779)	8.74 (222)	205 (93)
RNYM5-1633Y-EP(-B)-20~40				28.80 (732)		178 (81)			202 (92)
RNYM8-1633Y-EP(-B)-20~40	7.5 X 4 (5.5 X 4)			206 (93)	32.36 (822)	229 (104)			
RNYM05-1640Y(-B)-300~1440	1/2 X 4 (0.4 X 4)	4.63 (118)	-	21.36 (543)	4.88 (124)	134 (61)	22.62 (575)	4.88 (124)	137 (62)
RNYM08-1640Y(-B)-300~1440	3/4 X 4 (0.55 X 4)	5.67 (144)	3.74 (95)	23.78 (604)	5.94 (151)	137 (63)	25.47 (647)	5.94 (151)	143 (65)
RNYM1-1640Y-AV(-B)-300~1440	1 X 4 (0.75 X 4)	5.98 (152)		25.39 (645)	6.22 (158)	152 (69)	27.89 (709)	6.22 (158)	162 (74)
RNYM08-1630Y-AV(-B)-100~120	3/4 X 4 (0.55 X 4)	5.86 (149)	3.54 (90)	23.33 (593)	6.30 (160)	117 (54)	25.77 (655)	6.30 (160)	128 (58)
RNYM08-1631Y-AV(-B)-150~240				24.04 (611)		112 (51)			26.48 (673)
RNYM02-1640Y-AV(-B)-600~1440	1/4 X 4 (0.2 X 4)	4.63 (118)	-	21.36 (543)	4.88 (124)	134 (61)	22.62 (575)	4.88 (124)	137 (62)
RNYM03-1640Y-AV(-B)-600~1440	1/3 X 4 (0.25 X 4)								
RNYM05-1640Y-AV(-B)-300~1440	1/2 X 4 (0.4 X 4)	5.67 (144)	3.74 (95)	23.78 (604)	5.94 (151)	142 (151)	25.47 (647)	5.94 (151)	148 (67)

Hyponic®

Dimensions

Dimensions

Frame Size 1600 RNYM-1634Y

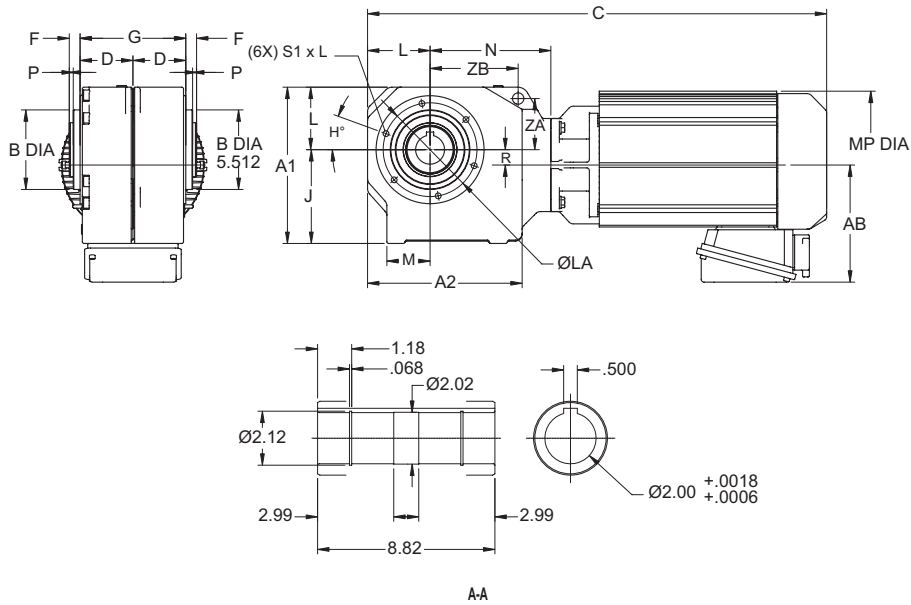

All dimensions are in inches (mm).

Hyponic®

Dimensions

Model	A1	A2	B min	B max	D	F	G	H	J	L	N	P	R	ZA	ZB	LA	SxL
1634Y	10.83 (275)	10.83 (275)	5.5102 (139.960)	5.5118 (140)	3.66 (93)	0.75 (19)	7.32 (186)	20.00 (508)	6.50 (165)	4.33 (110)	8.37 (213)	0.28 (7)	1.06 (27)	3.54 (90)	6.1 (155)	6.5 (165)	M12 x 0.87 (M12 x 22)

Model	HP x P (kW x P)	AB	ZA	Without Brake			With Brake		
				C	MP	Weight lb (kg)	C	MP	Weight lb (kg)
RNYM8-1634Y-EP (-B)-5~25	7.5 x 4 (5.5 x 4)	7.34 (186)	4.96 (126)	28.97 (736)	8.74 (222)	258 (117)	32.53 (826)	8.74 (222)	282 (128)
RNYM10-1634Y-EP (-B)-5~25	10 x 4 (7.5 x 4)	9.04 (230)	5.79 (147)	29.70 (754)	10.24 (260)	285 (130)	33.83 (859)	10.24 (260)	330 (150)
RNYM15-1634Y-EP (-B)-5~20	15 x 4 (11 x 4)			32.14 (816)			36.27 (921)		342 (156)

4

Options

Hyponic®

Options

Plug-in Solid Output Shaft

Frame Size 1100 ~ 1300

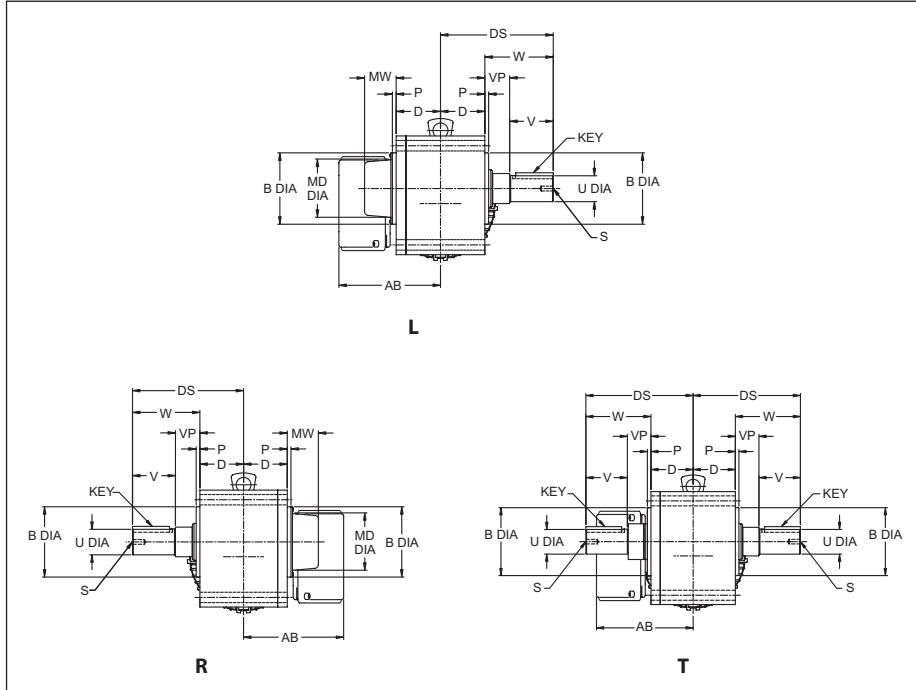

All dimensions are in inches.

Hyponic®

Options

Model	B min	B max	D	DS	H	P	MD	MW
1120L/R/TY-X1	2.046	2.047	1.30	3.27	0.26	0.24	2.20	0.79
1220L/R/TY-X1	3.070	3.071	1.46	3.96	0.35	0.20	2.32	1.26
1230L/R/TY-X1			1.61	4.11				
1320L/R/TY-X1	3.345	3.346	1.81	4.61	0.43	0.20	2.64	1.26
1330L/R/TY-X1								
1340L/R/TY-X1								

Model	Output Shaft						
	U min	U max	W	V	VP	S	Key
1120L/R/TY-X1	0.749	0.750	1.97	1.10	0.87	10-32 UNF x 0.630	3/16 x 3/16
1220L/R/TY-X1	0.999	1.000	2.50	1.42	1.08	5/16-18 UNC x 0.630	1/4 x 1/4
1230L/R/TY-X1							
1320L/R/TY-X1	1.249	1.250	2.80	1.65	1.14		
1330L/R/TY-X1							
1340L/R/TY-X1							

Plug-in Solid Output Shaft

Frame Size 1400 ~ 1600

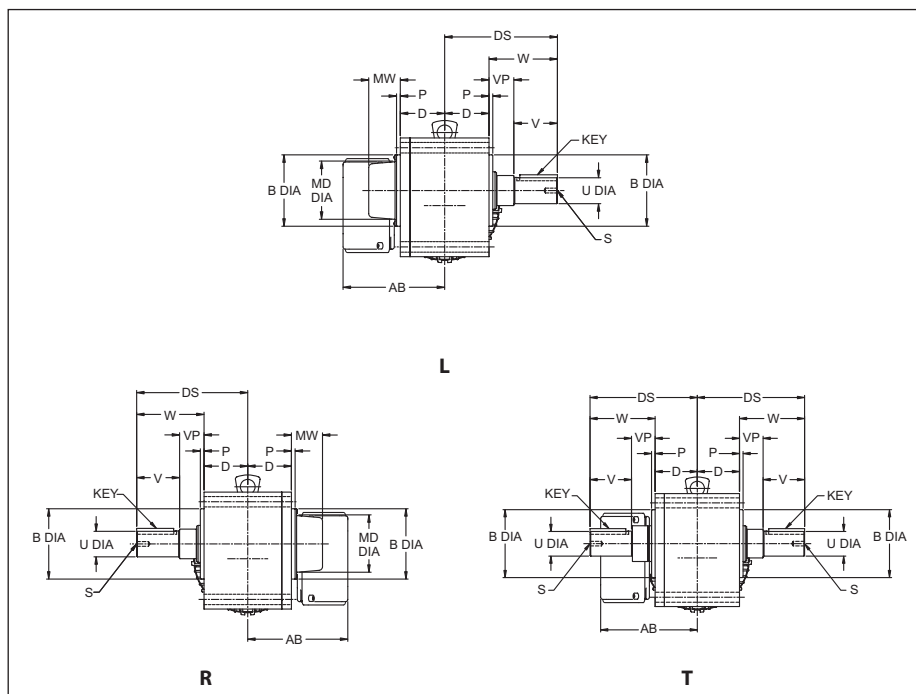

All dimensions are in inches.

Model	B min	B max	D	DS	H	P	MD	MW
1420L/R/TY-X1								
1430L/R/TY-X1	3.739	3.740	2.32	5.91				
1440L/R/TY-X1					0.55	0.20	3.03	1.65
1520/21/22/L/R/TY-X1								
1530/31/L/R/TY-X1	4.329	4.331	2.68	7.40				
1540/L/R/TY-X1								
1630/31/32/33/L/R/TY-X1	5.904	5.906	3.66	8.58	0.87	0.47	4.49	2.40
1640L/R/TY-X1								

Model	Output Shaft						
	U min	U max	W	V	VP	S	Key
1420L/R/TY-X1							
1430L/R/TY-X1	1.374	1.375	3.58	2.28	1.30	5/16-18 UNC x 0.630	5/16 x 5/16
1440L/R/TY-X1							
1520/21/22/L/R/TY-X1 ^[1]							
1530/31/L/R/TY-X1 ^[1]	1.749	1.750	4.72	3.23	1.50	3/8-16 UNC x 0.709	3/8 x 3/8
1540/L/R/TY-X1 ^[1]							
1630/31/32/33/L/R/TY-X1	1.999	2.000	4.92	3.23	1.69	3/8-16 UNC x 18	1/2 x 1/2
1640L/R/TY-X1							

Note: [1] For double extended output shaft, U min=1.499, U max = 1.500.

Plug-in Shaft with Bolt-on Feet

Frame Size 1100 ~ 1500

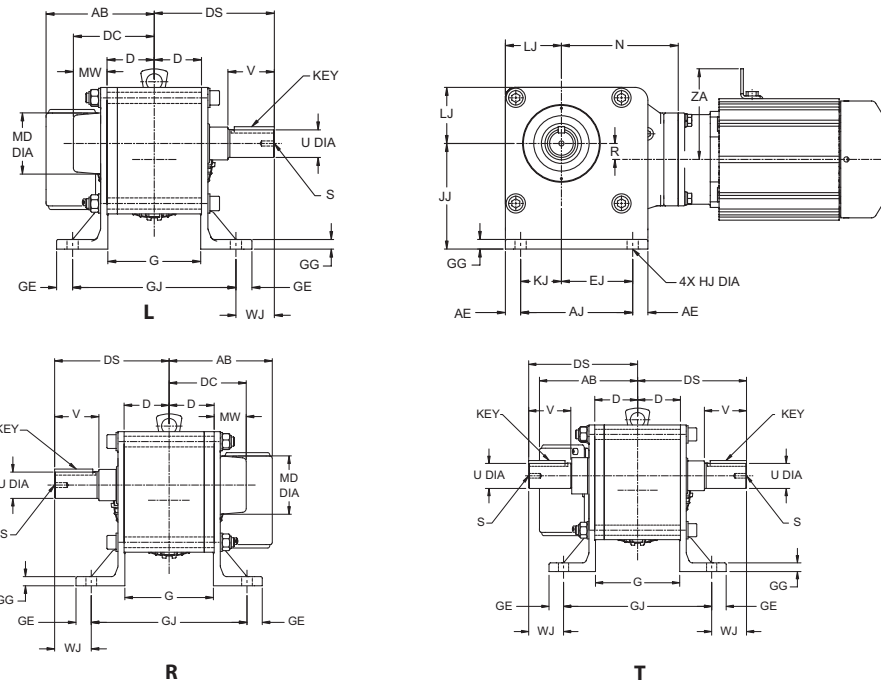

All dimensions are in inches.

Model	AJ	AE	D	DS	DC	G	GJ	GE	JJ	LJ	GG	KJ	EJ	HJ	N	R	MD	MW
1120L/R/TY-J1	2.76	0.39	1.30	3.27	2.09	2.52	4.72	0.39	3.54	1.57	0.39	1.26	1.50	0.35	3.23	0.79	2.20	0.79
1220L/R/TY-J1	4.13	0.43	1.46	3.96	2.72	2.83	5.35	0.59	4.33	2.01	0.39	1.57	2.56	0.35	3.78	1.10	2.32	1.26
1230L/R/TY-J1			1.61	4.11	2.87	3.15	5.67								3.74	0.51		
1320L/R/TY-J1	4.96	0.51	1.81	4.61	3.07	3.54	6.46	0.79	4.41	2.36	0.47	1.85	3.11	0.43	4.69	1.08	2.64	1.65
1330L/R/TY-J1															4.25	0.43		
1340L/R/TY-J1															5.16	0.35		
1420L/R/TY-J1	5.51	0.75	2.32	5.91	3.98	4.57	8.03	0.79	5.20	2.76	0.47	2.01	3.50	0.55	5.75	0.79	3.03	1.65
1430L/R/TY-J1															5.12	0.55		
1440L/R/TY-J1															6.42	0.43		
1520L/R/TY-J1	6.81	0.79	2.68	7.40	4.33	5.28	9.61	0.79	6.30	3.31	0.59	2.52	4.29	0.71	7.01	1.10	3.54	1.65
1530/31/L/R/TY-J1															6.18	0.67		
1540L/R/TY-J1															7.76	0.55		

Options

Model	Output Shaft					
	U min	U max	WJ	V	S	Key
1120L/R/TY-J1	0.749	0.750	0.91	1.10	10-32 UNF x 0.630	3/16 x 3/16
1220L/R/TY-J1	0.999	1.000	1.28	1.42	5/16-18 UNC x 0.630	1/4 x 1/4
1230L/R/TY-J1						
1320L/R/TY-J1	1.249	1.250	1.38	1.65		
1330L/R/TY-J1						
1340L/R/TY-J1						
1420L/R/TY-J1	1.374	1.375	1.89	2.28	5/16 x 5/16	
1430L/R/TY-J1						
1440L/R/TY-J1						
1520L/R/TY-J1	1.749	1.750	2.60	3.23	3/8-16 UNC x 0.709	3/8 x 3/8
1530/31/L/R/TY-J1						
1540L/R/TY-J1						

Extended Flange

Frame Size 1100 ~ 1500

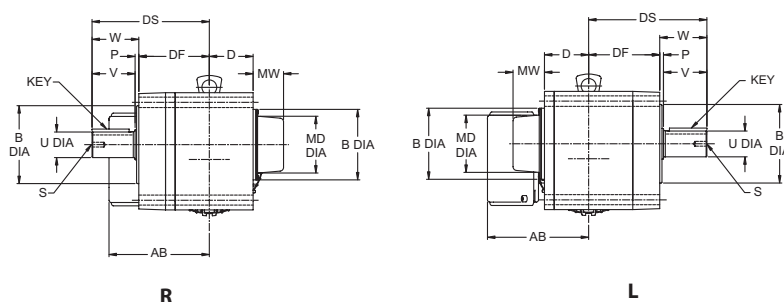

All dimensions are in inches.

Model	B min	B max	H	D	DF	P	DS	MD	MW
1120L/R-P1/Q1	2.361	2.362	0.26	1.30	2.50	0.12	3.80	2.20	0.79
1220L/R-P1/Q1	3.345	3.346	0.35	1.46	3.25		4.86	2.32	1.26
1230L/R-P1/Q1				1.61	2.50		4.11		
1320L/R-Y-P1/Q1	3.699	3.701	0.43	1.81	3.48		5.33	2.64	1.65
1330L/R-Y-P1/Q1					2.50		4.35		
1340L/R-Y-P1/Q1					3.74		6.22		
1420L/R-Y-P1/Q1	4.132	4.134	0.55	2.32	3.25		5.73	3.03	1.65
1430L/R-Y-P1/Q1					3.74		6.22		
1440L/R-Y-P1/Q1					3.25		5.73		
1520L/R-Y-P1/Q1	4.723	4.724	0.55	2.68	3.74		7.17	3.54	1.65
1530/31/L/R-Y-P1/Q1			0.71						
1540L/R-Y-P1/Q1			0.71						

Model	Output Shaft					
	U min	U max	W	V	S	Key H
1120L/R-P1/Q1	0.749	0.750	1.30	1.10	10-32 UNF x 0.630	3/16 x 3/16
1220L/R-P1/Q1	0.999	1.000	1.61	1.42	5/16-18 UNC x 0.630	1/4 x 1/4
1230L/R-P1/Q1						
1320L/R-Y-P1/Q1	1.249	1.250	1.85	1.65		
1330L/R-Y-P1/Q1						
1340L/R-Y-P1/Q1						
1420L/R-Y-P1/Q1	1.374	1.375	2.48	2.28	5/16 x 5/16	
1430L/R-Y-P1/Q1						
1440L/R-Y-P1/Q1						
1520L/R-Y-P1/Q1	1.749	1.750	3.43	3.23	3/8-16 UNC x 0.709	3/8 x 3/8
1530/31/L/R-Y-P1/Q1						
1540L/R-Y-P1/Q1						

Options

Metric Flange

Frame Size 1320 ~ 1531

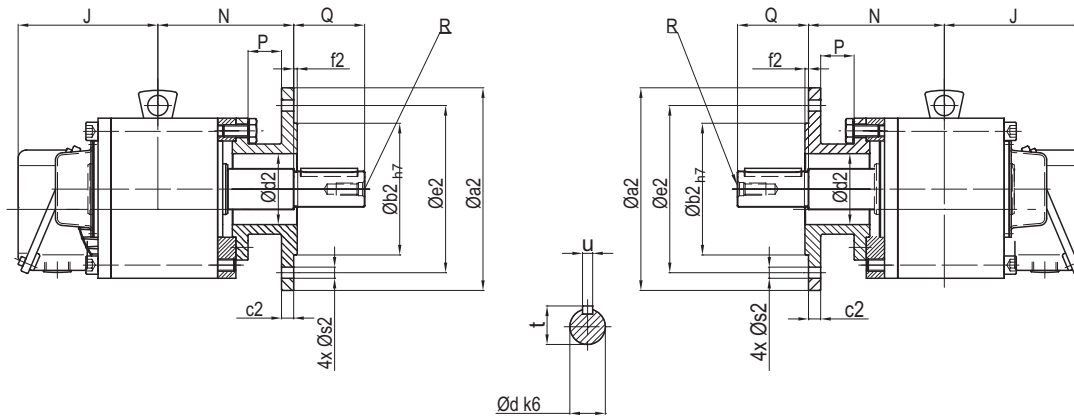

All dimensions are in mm.

Frame	HP	a2	b2	c2	d2	e2	f2	s2	J	N	d k6	P	Q	R	t	u
1320	1	160	110	10	60	130	3.5	9	138	111	30	30	60	M210x22	33	8
1420	1	200	130	12	70	165	3.5	11	138	134	35	33	70	M12x28	38	10
	143															
	143															
1520	1	250	180	15	85	215	4	13.5	138	167	40	51	80	M12x28	43	12
	1.5								143							
	2								143							
	3								150							
1521	3	250	180	15	85	215	4	13.5	150	167	40	51	80	M12x28	43	12
	5								166							
1522	5 7.5	250	180	15	85	215	4	13.5	166	167	40	51	80	M12x28	43	12
1530	1	250	180	15	85	215	4	13.5	138	169	40	49	80	M12x28	43	12
1531	1	250	180	15	85	215	4	13.5	138	169	40	49	80	M12x28	43	12
	1.5								143							
	2								143							
	3								150							

Hyponic®

Options

Flange Shaft

Frame Size 1420 ~ 1531

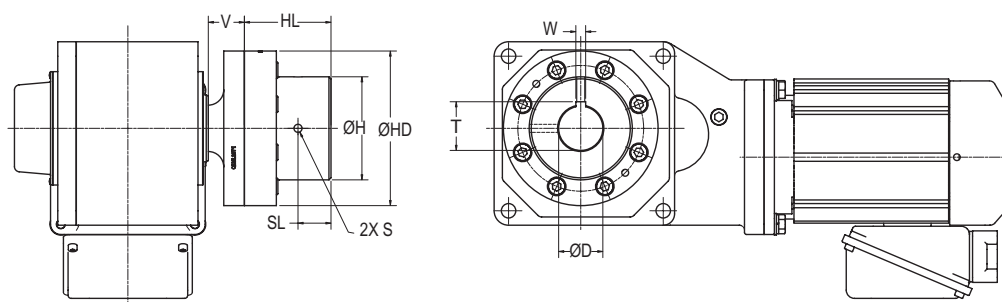

All dimensions are in inches.

Frame	H	HD	HL	SL	V
1420Y	3.94	5.91	3.31	1.26	1.38
1520Y					
1530Y					
1531Y					

Shaft Diameter	D	S	T	W
1-3/8	1.375 0.0015 -0	1/4"-20UNC	1.518 +0.010 -0.000	0.3125 +0.002 -0.000
1-7/16	1.4375 0.0015 -0	5/16"-18UNC	1.605 +0.010 -0.000	0.3750 +0.002 -0.000
1-11/16	1.6875 0.0015 -0	5/16"-18UNC	1.859 +0.010 -0.000	0.3750 +0.002 -0.000
1-15/16	1.9375 0.0015 -0	3/8"-16UNC	2.160 +0.010 -0.000	0.5000 +0.002 -0.000

Hyponic®

Options

T-Type Torque Arm

Frame Size 1420 ~ 1531

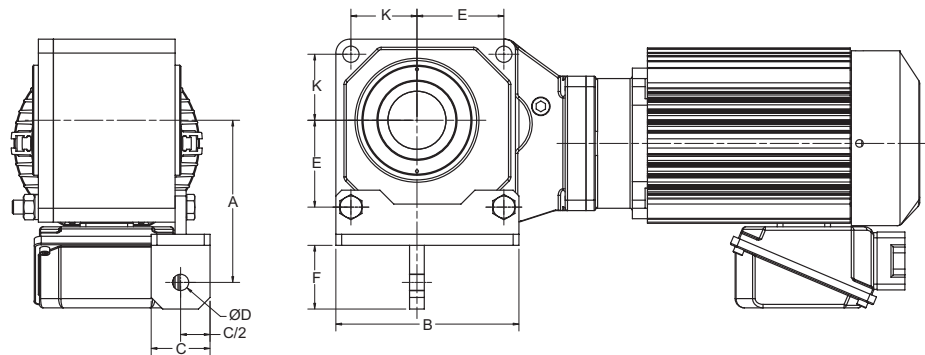

All dimensions are in inches.

Frame	A	B	C	ØD	E	F	K
1420Y	5.51	6.22	2.00	0.55	2.95	2.17	2.24
1520Y	5.67	7.00	2.00	0.55	3.15	2.28	2.76
1530Y	7.83	8.39	2.50	0.71	4.29	2.76	2.52
1531Y	7.83	8.39	2.50	0.71	4.29	2.76	2.52

Hyponic®

Options

Shaft Dimensions

Symbols: ● Standard ○ Optional ◆ Standard Stainless Steel (AIS 304)
Consult factory for price and delivery.

Table 4.1 Hollow Shaft Dimensions (in.)

Bore Size (in.)	Frame Size					
	1120	1220 1230	1320 1330 1340	1420 1430 1440	1520 1521 1522 1530 1531 1540	1630 1631 1632 1633 1634 1640
3/4	●	○	○			
13/16		○	○			
7/8		○	○			
15/16		○	○			
1		●◆	○	○	○	
1-1/8			○◆	○	○	
1-3/16			○◆	○	○	
1-1/4			●◆	○◆	○	
1-5/16				○	○	
1-3/8				●◆	○◆	
1-7/16				○ ^[1] ◆	○◆	
1-1/2					●◆	
1-5/8					○◆	○
1-11/16					○◆	○
1-3/4					○◆	○
1-7/8						○
1-15/16						○
2						●
2-1/16						○
2-1/8						○
2-3/16						○

Table 4.2 Hollow Shaft Metric Bore Dimensions (mm)

Bore Size (mm)	Frame Size						
	1120	1220 1230	1320 1330 1340	1420 1440	1430	1520 1521 1522 1530 1531 1540	1630 1631 1632 1633 1634 1640
20	●	○	○				
25		●	○	○	○		
30			●	○	○	○	
35				●	●	○	
38					○	○	
40						○	○
45						●	○
50							○
55							●

Table 4.3 Solid Shaft Dimensions (in.)

Bore Size (in.)	Frame Size					
	1120	1220 1230	1320 1330 1340	1420 1430 1440	1520 1521 ^[3] 1522 ^[3] 1530 1531 1540	1630 1631 1632 1633 1640
3/4	●					
1		●				
1-1/4			●			
1-5/16						
1-3/8				●		
1-7/16						
1-1/2					● ^[2]	
1-3/4					●	
2						● ^[3]

Notes: [1] Special maximum bore size for frame size 1420 and 1430 is 1-7/16"; maximum bore size for frame sizes 1440 is 1-3/8".

[2] Standard shaft dimension for double extended type shaft.

[3] Plug-in shaft only, not available with foot.

Options

Shrink Disc

A shrink disc provides a reliable, keyless, high-strength connection to the driven shaft with zero backlash. It is ideal for applications that typically require an interference between the shaft and hollow bore. Sumitomo strongly recommends a shrink disc for applications involving frequent starts per hour.

When ordering, use the Special Specification Code (SSC) R61 for right side (when viewed from the motor end), or R62 for left side (when viewed from the motor end).

The user shaft should conform to JIS h6 tolerances. Shafts outside that range may not develop sufficient clamping force. The shaft surface finish should be between 63 to 125 micro-inches RMS.

Shrink Disc Availability:

Not available for 5:1 ratio, frame sizes 1120~1521.

Not available for 10:1 ratio, frame sizes 1630 to 1633.

Table 4.4 Shrink Disc Availability

Symbols: ● Standard ○ Option ◆ Standard Stainless Steel (AIS 304)

Bore Size (in.)	Driven Shaft Tolerance (JIS h6)	Frame Size*												
		1120	1220	1230	1320	1330 1340	1420	1430	1440	1520 1521 1522	1530 1540	1531	1630 1632 1633 1634	1631 1640
3/4	+0.0000 -0.0051	●	○											
13/16	+0.0000 -0.0051		○											
7/8	+0.0000 -0.0051		○	○	○									
15/16	+0.0000 -0.0051		○	○	○									
1	+0.0000 -0.0051		●◆	●◆	○									
Hyponic® 1-1/8	+0.0000 -0.0051				○◆	○◆	○							
Options 1-3/16	+0.0000 -0.0063				○◆	○◆	○	○	○	○				
1-1/4	+0.0000 -0.0063				●◆	●◆	○◆	○◆	○◆	○				
1-5/16	+0.0000 -0.0063						○	○	○	○		○		
1-3/8	+0.0000 -0.0063						●◆	●◆	●◆	○◆	○◆	○◆		
1-7/16	+0.0000 -0.0063						○◆	○◆	◆	○◆	○◆	○◆		
1-1/2	+0.0000 -0.0063									●◆	●◆	●◆		
1-5/8	+0.0000 -0.0063									○◆	○◆	○◆		
1-11/16	+0.0000 -0.0063									○◆	○◆	○◆		
1-3/4	+0.0000 -0.0063									○◆	○◆	○◆	○	
1-7/8	+0.0000 -0.0063												○	
1-15/16	+0.0000 -0.0063												○	
2	+0.0000 -0.0075												●	●
2-1/16	+0.0000 -0.0075												○	○
2-1/8	+0.0000 -0.0075												○	○
2-3/16	+0.0000 -0.0075												○	○

Food Industry Packages

Four food-grade packages are available for use in machinery where there is incidental food contact. (Chemi SHIELD, SHIELD360, Food-Grade, and Ultra SHIELD360)

Modification	Chemical Duty	Chemi SHIELD 360*	Low Temp	Weather Proof IP54	IP55	Food-Grade	SHIELD 360*	Ultra SHIELF 360*	Micro SHIELD 360*
Gasketed Conduit Box	X	X		X	X	X	X		X
V Ring Seal- Fan End	X	X		X	X	X	X		X
Silicone Oil Seal			X						
Special Varnish On Windings			X						
Sealer @ Joints	X	X	X	X	X	X	X		X
Stainless Steel or Zinc Plated Hardware	X								
Special Fan			X						
DuPont Alesta® AM Powder Coat	X				X	X			X
FDA White Acrylic Top Coat							X		
FDA Stainless Steel Grey Acrylic Top Coat		X							
Stainless Steel Grey 2-Part Epoxy Top Coat									
Brake Cover and Seal	X	X		X	X		X		X
Reducer Portion									
DuPont Alesta® AM Powder Coat	X				X	X			X
FDA White Acrylic Top Coat							X		
FDA Stainless Steel Grey Acrylic Top Coat		X							
Stainless Steel Grey 2-Part Epoxy Top Coat								X	
FDA Approved Grease						X		X	X
Low Temp Grease / Oil			X						
Triple Lip Nitrile Seals				X	X	X	X		
Silicone Seals			X						
FKM Antimicrobial Seals	X	X						X	X
Stainless Steel or Zinc Plated Hardware									X
Stainless Steel or Tesa Nameplate	X	X						X	X
Stainless Steel Output Shaft		X						X	X

Notes: † Modification list prices are in addition to base unit list price.

* Available from Glendale Heights, IL only. UltraSHIELD360 available for Quill only

Stainless Steel Solid Shaft - maximum torque ratings with standard solid shaft diameters are the same as those listed in this catalog for standard models. Consult the factory when ordering smaller than standard diameters, or if there will be overhung load.

* UltraShield360™ available in quill input option only

Low Temp Package = -30 degrees C Maximum. For lower temperature requirements consult factory.

High Temp Package = 50 degrees C Maximum. For higher temperature requirements consult factory.

Hyponic®

Options

Page intentionally left blank.

5

Technical Information

Hyponic®

Technical
Information

Exact Ratios

The exact reduction ratios for the Hyponic can be calculated given the number of gear teeth in a reduction stage.

Per reduction stage, the reduction ratio is determined by dividing the number of teeth in the gear by the number of teeth in the pinion. The overall gearbox reduction ratio is the product of the individual stage reduction ratios.

$$\text{Overall Reduction Ratio} = i_{\text{OVERALL}} = (1\text{ST}_{\text{GEAR}} / 1\text{ST}_{\text{PINION}}) (2\text{ST}_{\text{GEAR}} / 2\text{ST}_{\text{PINION}}) (3\text{ST}_{\text{GEAR}} / 3\text{ST}_{\text{PINION}}) (4\text{ST}_{\text{GEAR}} / 4\text{ST}_{\text{PINION}})$$

- where:
- 1ST_{GEAR}, 1ST_{PINION} = Tooth count of first stage pinion and gear respectively
 - 2ST_{GEAR}, 2ST_{PINION} = Tooth count of second stage pinion and gear respectively
 - 3ST_{GEAR}, 3ST_{PINION} = Tooth count of third stage pinion and gear respectively (if applicable)
 - 4ST_{GEAR}, 4ST_{PINION} = Tooth count of fourth stage pinion and gear respectively (if applicable)

Table 5.1: Tooth Counts and Calculated Reduction Ratios for Nominal Ratios 5-240:1

Normal Ratio	Frame Size	Number of Teeth				Calculated Ratio
		1ST _{PINION}	1ST _{GEAR}	2ST _{PINION}	2ST _{GEAR}	
5	1120	9	45	38	38	5.0000
	1320	9	45	37	37	5.0000
	1420	9	45	39	39	5.0000
	1520	9	45	39	39	5.0000
	1521	9	45	39	39	5.0000
	1522	11	44	34	43	5.0588
	1634	12	42	35	49	4.9000
7	1120	9	45	32	45	7.0313
	1320	9	45	32	45	7.0313
	1420	9	45	33	46	6.9697
	1520	9	45	32	45	7.0313
	1521	9	45	32	45	7.0313
	1522	11	44	28	49	7.0000
	1634	12	42	28	57	7.1250

Hyponic®

Table 5.1: Tooth Counts and Calculated Reduction Ratios for Nominal Ratios 5-240:1 (cont.)

Normal Ratio	Frame Size	Number of Teeth				Calculated Ratio
		1ST _{PINION}	1ST _{GEAR}	2ST _{PINION}	2ST _{GEAR}	
10	1120	9	45	26	51	9.8077
	1320	9	45	26	51	9.8077
	1420	9	45	26	52	10.0000
	1520	9	45	26	51	9.8077
	1521	9	45	26	51	9.8077
	1522	11	44	22	55	10.0000
	1630	6	60	44	45	10.2273
	1632	7	49	36	53	10.3056
12	1634	12	42	22	63	10.0227
	1120	9	45	23	54	11.7391
	1320	9	45	23	54	11.7391
	1420	9	45	23	55	11.9565
	1520	9	45	23	54	11.7391
	1521	9	45	23	54	11.7391
	1522	11	44	19	58	12.2105
	1630	6	60	40	48	12.0000
15	1632	7	49	32	57	12.4688
	1634	12	42	19	65	11.9737
	1120	9	45	19	58	15.2632
	1320	9	45	19	58	15.2632
	1420	9	45	20	59	14.7500
	1520	9	45	19	58	15.2632
	1521	9	45	19	58	15.2632
	1522	11	44	16	61	15.2500
15	1630	6	60	36	53	14.7222
	1632	7	49	29	60	14.4828
	1634	12	42	16	69	15.0938

Exact Ratios (cont.)

Table 5.1: Tooth Counts and Calculated Reduction Ratios for Nominal Ratios 5-240:1 (cont.)

Normal Ratio	Frame Size	Number of Teeth						Calculated Ratio
		1ST _{PINION}	1ST _{GEAR}	2ST _{PINION}	2ST _{GEAR}	3ST _{PINION}	3ST _{GEAR}	
20	1120	9	45	15	62	—	—	20.6667
	1320	9	45	15	62	—	—	20.6667
	1420	9	45	16	63	—	—	19.6875
	1520	9	45	15	62	—	—	20.6667
	1521	9	45	15	62	—	—	20.6667
	1630	6	60	29	60	—	—	20.6897
	1632	7	49	23	67	—	—	20.3913
	1633	9	45	17	71	—	—	20.8824
25	1634	12	42	24	39	17	60	20.0735
	1120	9	45	13	64	—	—	24.6154
	1320	9	45	13	64	—	—	24.6154
	1420	9	45	13	65	—	—	25.0000
	1520	9	45	13	64	—	—	24.6154
	1521	9	45	13	64	—	—	24.6154
	1630	6	60	25	62	—	—	24.8000
	1632	7	49	20	69	—	—	24.1500
30	1633	9	45	15	73	—	—	24.3333
	1634	12	42	21	43	17	60	25.2941
	1120	9	45	11	66	—	—	30.0000
	1320	9	45	11	66	—	—	30.0000
	1420	9	45	11	67	—	—	30.4545
	1520	9	45	11	66	—	—	30.0000
	1630	6	60	23	67	—	—	29.1304
40	1632	7	49	17	71	—	—	29.2353
	1633	9	45	25	42	18	63	29.4000
	1120	6	60	15	62	—	—	41.3333
	1320	6	60	15	62	—	—	41.3333
	1420	6	60	16	63	—	—	39.3750
	1520	6	60	15	62	—	—	41.3333
	1531	9	45	20	49	20	64	39.2000
	1630	6	60	17	71	—	—	41.7647
50	1632	7	49	25	42	18	63	41.1600
	1633	9	45	20	46	18	63	40.2500
	1120	6	60	13	64	—	—	49.2308
	1320	6	60	13	64	—	—	49.2308
	1420	6	60	13	65	—	—	50.0000
	1520	6	60	13	64	—	—	49.2308
	1531	9	45	17	53	20	64	49.8824
50	1630	6	60	15	73	—	—	48.6667
	1632	7	49	22	44	18	63	49.0000

Table 5.1: Tooth Counts and Calculated Reduction Ratios for Nominal Ratios 5-240:1 (cont.)

Normal Ratio	Frame Size	Number of Teeth						Calculated Ratio
		1ST _{PINION}	1ST _{GEAR}	2ST _{PINION}	2ST _{GEAR}	3ST _{PINION}	3ST _{GEAR}	
60	1120	6	60	11	66	—	—	60.0000
	1320	6	60	11	66	—	—	60.0000
	1420	6	60	11	67	—	—	60.9091
	1520	6	60	11	66	—	—	60.0000
	1531	9	45	15	54	20	64	57.6000
	1630	6	60	25	42	18	63	58.8000
80	1632	7	49	20	46	18	63	56.3500
	1230	6	60	16	47	22	61	81.4489
	1330	6	60	18	50	20	59	81.9444
	1430	6	60	18	49	21	62	80.3704
	1530	6	60	20	49	20	65	79.6250
	1531	9	45	14	55	17	67	77.4160
100	1630	6	60	20	46	18	63	80.5000
	1230	6	60	14	51	22	61	101.006
	1330	6	60	15	52	20	59	102.267
	1430	6	60	15	52	21	62	102.349
	1530	6	60	17	53	20	65	101.324
120	1630	6	60	17	50	18	63	102.941
	1230	3	45	14	51	22	61	151.510
	1330	3	45	15	52	20	59	153.400
	1430	3	45	15	52	21	62	153.524
	1530	3	45	17	53	20	64	149.647
150	1631	3	45	17	50	18	63	154.412
	1230	3	45	14	51	22	61	151.510
	1330	3	45	15	52	20	59	153.400
	1430	3	45	15	52	21	62	153.524
	1530	3	45	17	53	20	64	149.647
200	1631	3	45	17	50	18	63	154.412
	1230	3	45	11	53	22	61	200.393
	1330	3	45	12	54	20	59	199.125
	1430	3	45	12	54	21	62	199.286
	1530	3	45	14	55	20	64	188.571
240	1631	3	45	18	49	14	67	195.417
	1230	3	45	11	53	20	64	231.273
	1330	3	45	12	54	18	62	232.500
	1430	3	45	12	54	18	64	240.000
	1530	3	45	14	55	17	67	232.248
	1631	3	45	15	51	14	67	244.071

Hyponic®

Technical Information

Exact Ratios (cont.)

Table 5.2: Tooth Counts and Calculated Reduction Ratios for Nominal Ratios 300-1440:1

Normal Ratio	Frame Size	Number of Teeth								Calculated Ratio
		1ST _{PINION}	1ST _{GEAR}	2ST _{PINION}	2ST _{GEAR}	3ST _{PINION}	3ST _{GEAR}	4ST _{PINION}	4ST _{GEAR}	
300	1340	6	60	14	51	18	49	19	58	302.7192
	1440	6	60	15	52	18	53	20	59	301.1185
	1540	6	60	15	52	18	53	19	58	311.5945
	1640	6	60	17	53	18	59	23	67	297.6826
360	1340	6	60	14	51	18	49	19	58	302.7192
	1440	6	60	15	52	18	53	20	59	301.1185
	1540	6	60	15	52	18	53	19	58	311.5945
	1640	6	60	17	53	18	59	23	67	297.6826
480	1340	6	60	14	51	18	49	19	58	302.7192
	1440	6	60	15	52	18	53	20	59	301.1185
	1540	6	60	15	52	18	53	19	58	311.5945
	1640	6	60	17	53	18	59	23	67	297.6826
600	1340	6	60	14	51	18	49	11	66	595.0000
	1440	6	60	15	52	18	53	11	67	621.7239
	1540	6	60	13	54	18	53	13	64	602.1302
	1640	6	60	17	53	18	59	13	77	605.2765
720	1340	6	60	12	52	18	49	11	66	707.7778
	1440	6	60	13	54	18	53	11	67	744.9650
	1540	3	45	15	52	18	53	13	64	753.7778
	1640	6	60	15	55	18	59	13	77	711.8661
900	1340	3	45	14	51	18	49	11	66	892.5000
	1440	3	45	15	52	18	53	11	67	932.5859
	1540	3	45	13	54	18	53	13	64	903.1953
	1640	3	45	17	53	18	59	13	77	907.9148
1200	1340	3	45	11	53	18	49	11	66	1180.4545
	1440	3	45	12	54	18	53	11	67	1210.5682
	1540	3	45	11	55	17	55	13	64	1194.5701
	1640	3	45	14	55	18	59	13	77	1144.0705
1440	1340	3	45	11	53	16	51	11	66	1382.2159
	1440	3	45	12	54	16	55	11	67	1413.2813
	1540	3	45	11	55	15	57	13	64	1403.0769
	1640	3	45	14	55	15	60	13	77	1396.1538

Hyponic®

Technical Information

Shaft Rotation

Figure 5.1 Counter Clockwise Ratios

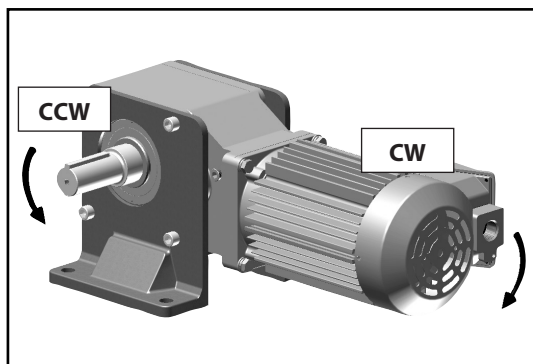

Figure 5.2 Clockwise Ratios

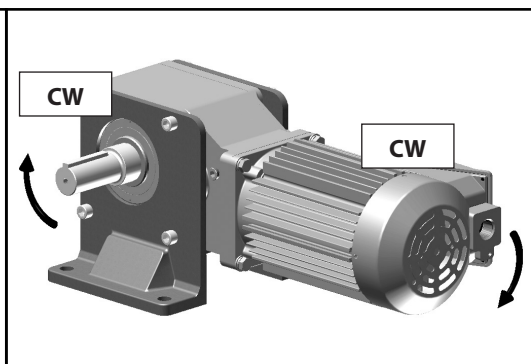

Table 5.3 Shaft Rotation Direction

Model	Counter Clockwise Reduction Ratio (:1)	Model	Clockwise Reduction Ratio (:1)
1120	5, 7, 10, 12, 15, 20, 25, 30, 40, 50, 60	1120	–
1220	5, 7, 10, 12, 15, 20, 25, 30, 40, 50, 60	1220	–
1230	–	1230	80, 100, 120, 150, 200, 240
1320	5, 7, 10, 12, 15, 20, 25, 30, 40, 50, 60	1320	–
1330	–	1330	80, 100, 120, 150, 200, 240
1340	300, 360, 480, 600, 720, 900, 1200, 1440	1340	–
1420	5, 7, 10, 12, 15, 20, 25, 30, 40, 50, 60	1420	–
1430	–	1430	80, 100, 120, 150, 200, 240
1440	300, 360, 480, 600, 720, 900, 1200, 1440	1440	–
1520	5, 7, 10, 12, 15, 20, 25, 30, 40, 50, 60	1520	–
1521	5, 7, 10, 12, 15, 20, 25	1521	–
1522	5, 7, 10, 12, 15	1522	–
1530	–	1530	80, 100, 120, 150, 200, 240
1531	–	1531	40, 50, 60, 80
1540	300, 360, 480, 600, 720, 900, 1200, 1440	1540	–
1630	10, 12, 15, 20, 25, 30, 40, 50	1630	60, 80, 100, 120
1631	–	1631	150, 200, 240
1632	10, 12, 15, 20, 25, 30	1632	40, 50, 60
1633	20, 25	1633	30, 40
1634	5, 7, 10, 12, 15	1634	20, 25
1640	300, 360, 480, 600, 720, 900, 1200, 1440	1640	–

Hyponic®

Technical Information

Special Load Guidelines Overhung Load

Reducer/Gearmotor Allowable Overhung Load

When a sprocket, sheave, or gear is mounted on the shaft of a reducer, an overhung load is applied on that shaft. It is necessary to check if the shaft of the Hyponic® Speed Reducer will allow the overhung load. Calculate the overhung load using this formula:

$$Pr = \frac{TI}{R} \leq \frac{Pro}{Lf \cdot Cf \cdot Fs} \quad (\text{lbs, N})$$

LEGEND

- Pr: Actual radial load (lbs, N)
- TI: Actual transmitted torque on slow speed shaft of reducer (lb-in, N-m)
- R: Pitch circle radius of sprocket, gear, pulley, ect. (inch, meter)
- Pro: Allowable radial load (lbs, N)
- Cf: Coupling factor
- Fs: Shock factor
- Lf: Load Location factor = 1.0

Table 5.4 Load Connection Factor

Type of Connection		Cf
General Purpose Chain	Single Row	1.00
	Double Row	1.25
Machined Gear or Pinion		1.25
Synchronous Belt		1.50
V-Belt		1.50
Flat Belt		2.50

Table 5.5 Shock Factor

Shock Factor	Fs
No Shock	1.0
Moderate Shock	1.3
Heavy Shock	1.6

Table 5.6 RNFM-X1, RNHM-J1 Slow Speed Shaft Load Location Factor (Lf)

Model ^[1]	L (in.)									
	1/2	3/4	1	1-1/4	1-1/2	1-3/4	2	2-1/4	2-1/2	2-3/4
1120	1.05	1.18	1.25	1.32	1.38	1.44	1.51	1.57	1.67	1.80
1220/30/40	1.13	1.19	1.25	1.32	1.38	1.44	1.51	1.57	1.64	1.70
1320/30/40	1.13	1.19	1.25	1.32	1.38	1.44	1.51	1.57	1.64	1.70
1420/30/40	1.13	1.19	1.25	1.30	1.30	1.34	1.41	1.47	1.54	1.60
1520/21/22	1.13	1.19	1.25	1.30	1.30	1.34	1.41	1.47	1.54	1.60
1530/31/40	1.28	1.47	1.66	1.85	2.04	2.23	2.43	2.69	2.91	3.10
1630/31/32/33/40	1.00	1.00	1.05	1.10	1.10	1.14	1.20	1.20	1.24	1.30

Note: [1] Please refer to the Options section in this catalog for the availability of feet.

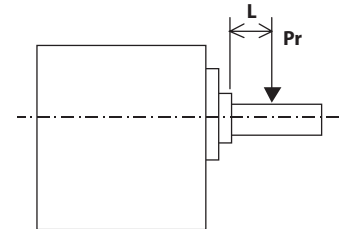

Figure 5.3

Table 5.7 RNFM-P1, Q1 Extended Flange Slow Speed Shaft Load Location Factor (Lf)

Model	L (in.)									
	1/2	3/4	1	1-1/4	1-1/2	1-3/4	2	2-1/4	2-1/2	2-3/4
1120	1.24	1.32	1.39	1.47	1.55	1.62	1.70	1.77	1.85	1.93
1220	1.37	1.44	1.51	1.58	1.65	1.72	1.79	1.85	1.92	1.99
1230	1.11	1.18	1.25	1.31	1.38	1.44	1.51	1.57	1.64	1.70
1320	1.29	1.35	1.41	1.47	1.53	1.59	1.65	1.71	1.77	1.83
1330/40	1.06	1.12	1.18	1.24	1.30	1.36	1.42	1.48	1.54	1.60
1420	1.18	1.23	1.28	1.33	1.38	1.43	1.48	1.52	1.57	1.62
1430/40	1.09	1.13	1.18	1.23	1.28	1.33	1.38	1.42	1.47	1.52
1520	1.10	1.14	1.19	1.23	1.27	1.31	1.36	1.40	1.47	1.56
1530/31/40	1.14	1.29	1.48	1.68	1.88	2.08	2.28	2.47	2.67	2.87

Special Load Guidelines Inertia

Table 5.8 Reducer Moment of Inertia, Ratios 5 ~ 240

Units: lb-inch² (x 10⁻⁴ kg-m²)

Model	Reduction Ratio																
	5	7	10	12	15	20	25	30	40	50	60	80	100	120	150	200	240
1120	0.149	0.145	0.143	0.143	0.142	0.142	0.141	0.141	0.134	0.134	0.134	-	-	-	-	-	-
1220	0.216	0.200	0.194	0.192	0.190	0.189	0.188	0.188	0.168	0.168	0.168	-	-	-	-	-	-
1230	-	-	-	-	-	-	-	-	-	-	-	0.135	0.135	0.135	0.134	0.134	0.134
1320	0.351	0.336	0.323	0.317	0.310	0.304	0.302	0.300	0.238	0.238	0.237	-	-	-	-	-	-
1330	-	-	-	-	-	-	-	-	-	-	-	0.169	0.168	0.168	0.166	0.166	0.166
1420	0.647	0.607	0.566	0.553	0.540	0.525	0.515	0.510	0.367	0.364	0.363	-	-	-	-	-	-
1430	-	-	-	-	-	-	-	-	-	-	-	0.239	0.238	0.238	0.186	0.185	0.185
1520	2.977	2.840	2.743	2.704	2.656	2.616	2.599	2.582	2.009	2.008	2.004	-	-	-	-	-	-
1521	2.977	2.840	2.743	2.704	2.656	2.616	2.599	-	-	-	-	-	-	-	-	-	-
1522	2.977	2.840	2.743	2.704	2.656	2.616	-	-	-	-	-	-	-	-	-	-	-
1530	-	-	-	-	-	-	-	-	-	-	-	0.369	0.366	0.365	0.337	0.336	0.336
1531	-	-	-	-	-	-	-	-	1.135	1.135	1.135	1.135	-	-	-	-	-
1630	-	-	4.723	4.500	4.493	4.378	4.331	4.308	4.252	4.238	4.251	4.223	4.211	4.205	-	-	-
1631	-	-	-	-	-	-	-	-	-	-	-	-	-	-	4.090	4.089	4.085
1632	-	-	5.238	5.115	5.002	4.859	4.807	4.746	4.743	4.706	4.686	-	-	-	-	-	-

Table 5.9 Reducer Moment of Inertia, Ratios 300 ~ 1440 Units: lb-inch² (x 10⁻⁴ kg-m²)

Model	Reduction Ratio							
	300	360	480	600	720	900	1200	1440
1340	0.135	0.134	0.135	0.135	0.134	0.134	0.134	0.134
1440	0.168	0.168	0.168	0.168	0.168	0.166	0.166	0.166
1540	0.238	0.237	0.238	0.237	0.186	0.186	0.185	0.185
1640	0.366	0.365	0.368	0.365	0.364	0.337	0.336	0.336

Table 4.13 Moment of Inertia on Motor Shaft of N-Frame Integral Motor

Units: lb-inch² (x 10⁻⁴ kg-m²)

1 HP (0.75 kW) x 4 Pole		1.5 HP (1.1 kW) x 4 Pole		2 HP (1.5 kW) x 4 Pole		3 HP (2.2 kW) x 4 Pole		5 HP (3.7 kW) x 4 Pole	
Standard	w/ Brake	Standard	w/Brake	Standard	w/Brake	Standard	w/Brake	Standard	w/Brake
8.03 (23.5)	8.82 (25.8)	11.5 (33.7)	13.5 (39.6)	13.4 (39.1)	15.4 (45)	30.1 (88)	33.4 (97.8)	66.3 (194)	71.4 (209)
7.5 HP (5.5 kW) x 4 Pole		10 HP (7.5 kW) x 4 Pole		15 HP (11 kW) x 4 Pole					
Standard	w/ Brake	Standard	w/ Brake	Standard	w/ Brake				
99.4 (291)	105 (306)	140 (409)	154 (450)	192 (561)	206 (602)				

Table 5.11 Moment of Inertia on Motor Shaft of V-Frame Standard Integral Motor

Units: lb-inch² (x 10⁻⁴ kg-m²)

1/8 HP (0.1 kW) x 4 Pole		1/4 HP (0.2 kW) x 4 Pole		1/3 HP (0.25 kW) x 4 Pole		1/2 HP (0.4 kW) x 4 Pole		3/4 HP (0.55 kW) x 4 Pole	
Standard	w/ Brake	Standard	w/ Brake	Standard	w/ Brake	Standard	w/ Brake	Standard	w/ Brake
1.11 (3.25)	1.2 (3.5)	1.71 (5)	1.88 (5.5)	1.71 (5)	1.88 (5.5)	2.22 (6.5)	2.31 (6.75)	3.45 (10.1)	3.79 (11.1)

Table 5.12 Moment of Inertia on Motor Shaft of V-Frame AF Integral Motor

Units: lb-inch² (x 10⁻⁴ kg-m²)

1/8 HP (0.1 kW) x 4 Pole		1/4 HP (0.2 kW) x 4 Pole		1/3 HP (0.25 kW) x 4 Pole		1/2 HP (0.4 kW) x 4 Pole		3/4 HP (0.55 kW) x 4 Pole	
Standard	w/ Brake	Standard	w/ Brake	Standard	w/ Brake	Standard	w/ Brake	Standard	w/ Brake
1.71 (5)	1.88 (5.5)	2.22 (6.5)	2.31 (6.75)	2.22 (6.5)	2.31 (6.75)	4.1 (12)	4.44 (13)	6.32 (18.5)	7.11 (20.8)

Hyponic®

Technical Information

Construction

Construction

Figure 5.4 Hollow Shaft Type Example (RNYM1-1530-EP-120)

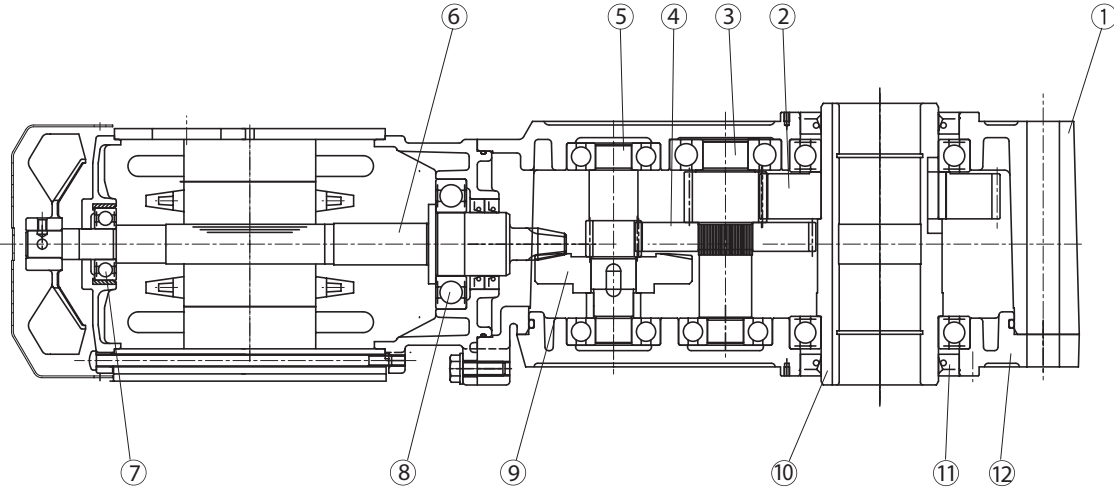

Table 5.13 Hollow Shaft Type Parts

Part No.	Description	Part No.	Description	Part No.	Description	Part No.	Description
1	Casing (1)	4	Gear	7	Bearing	10	Output shaft
2	Gear	5	Pinion shaft	8	Bearing	11	Oil seal
3	Pinion shaft	6	Hypoid pinion shaft	9	Hypoid gear	12	Casing (2)

Mounting

Recommended Shaft Tolerances for Hollow Bore Hyponic®

According to JIS standard and based on loading conditions, recommended shaft tolerances for hollow bore Hyponic® are:

- Steady, uniform loads: **JIS h6/js6 (low shock load)**
- Shock load or large overung load: **JIS js6/k6 (high shock load)**
- Snap ring size is in accordance with: **JIS B2804C**

Refer to tables 5.15 and 5.16 for corresponding shaft diameters.

Table 5.14 Metric Bore Shaft Diameters (mm)

Bore Size	Low Shock Load JIS h6/js6		High Shock Load JIS js6/k6	
	Min	Max	Min	Max
20	19.9870	20.0065	19.9935	20.0150
25	24.9870	25.0065	24.9935	25.0150
30	29.9870	30.0065	29.9935	30.0150
35	34.9840	35.0080	34.9920	35.0180
40	39.9840	40.0080	39.9920	40.0180
45	44.9840	45.0080	44.9920	45.0180
50	49.9840	50.0080	49.9920	50.0180
55	54.9810	55.0095	54.9905	55.0210

Table 5.15 Inch Bore Shaft Diameters (in.)

Bore Size	Low Shock Load JIS h6/js6		High Shock Load JIS js6/k6	
	Min	Max	Min	Max
3/4	0.74950	0.75025	0.74975	0.75060
13/16	0.81200	0.81275	0.81225	0.81310
7/8	0.87450	0.87525	0.87475	0.87560
15/16	0.93700	0.93775	0.93725	0.93810
1	0.99950	1.00025	0.99975	1.00060
1-1/8	1.12450	1.12525	1.12475	1.12560
1-3/16	1.18700	1.18775	1.18725	1.18810
1-1/4	1.24940	1.25030	1.24970	1.25070
1-5/16	1.31190	1.31280	1.31220	1.31320
1-3/8	1.37440	1.37530	1.37470	1.37570
1-7/16	1.43690	1.43780	1.43720	1.43820
1-1/2	1.49940	1.50030	1.49970	1.50070
1-5/8	1.62440	1.62530	1.62470	1.62570
1-11/16	1.68690	1.68780	1.68720	1.68820
1-3/4	1.74940	1.75030	1.74970	1.75070
1-7/8	1.87440	1.87530	1.87470	1.87570
1-15/16	1.93690	1.93780	1.93720	1.93820
2	1.99930	2.00030	1.99970	2.00080
2-1/16	2.06180	2.06280	2.06220	2.06330
2-1/8	2.12430	2.12530	2.12470	2.12580
2-3/16	2.18680	2.18780	2.18720	2.18830

4. Securing the Hyponic® Drive to Prevent Movement Away from the Machine Side (Figures 5.5 – 5.7)

Figure 5.5 Secured by Spacer and Snap Ring

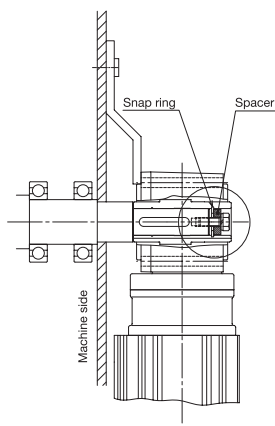

Figure 5.6 Secured by End Plate

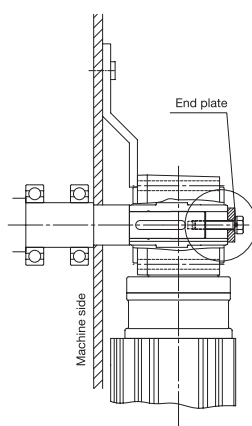
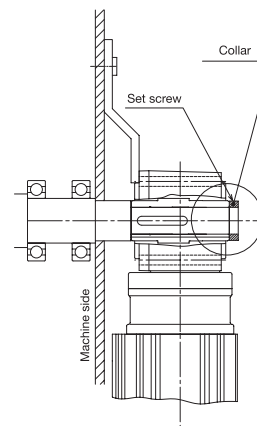

Figure 5.7 Secured by Set Screw and Collar



5. Flange Mounting and Casing Bottom Mounting (optional)

Handle with care. Do not apply excessive force to the driven shaft or hollow shaft by twisting the Hyponic® casing. Excessive force on the Hyponic® and bearing unit may damage internal parts.

Figure 5.8 Flange Mounting Surface

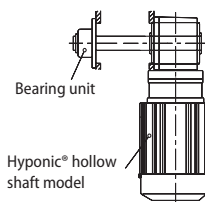

Correct

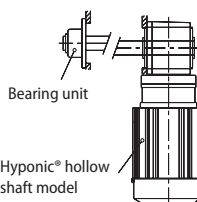

Incorrect: Poor concentricity of driven shaft and mounting flange

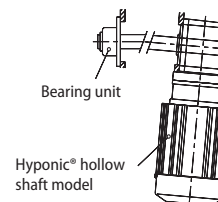

Incorrect: Poor perpendicularity of driven shaft center and mounting flange surface

Accessories Output Shaft Safety Cover, Torque Arm

Output Shaft Safety Cover

Included with all hollow bore models.

Table 5.16 Output Shaft Safety Cover Dimensions for keyed hollow bore.

Symbols: M: Screw size P: Thread pitch L: Thread length P.C.D: Mounting pitch N: Quantity

Model	Safety Cover							Output Shaft End		
	A	øB	C°	D	t	øP.C.D	N	MxPxL (mm)	øE	
1100	0.39	2.20	45	R0.12	0.08	<i>(screw not required for this model)</i>			1.18	5.14
1200	0.83	2.32	5	R0.20	0.08	2.76	2	M3x0.5x6	1.57	5.15
1300	0.83	2.64	5	R0.20	0.08	3.07	2	M3x0.5x6	1.77	5.15
1400	1.18	3.03	5	R0.20	0.08	3.46	2	M3x0.5x6	2.17	5.15
1500	1.18	3.54	5	R0.20	0.08	4.06	2	M3x0.5x6	2.56	5.15
1600	1.57	4.48	5	R0.20	0.08	5.31	2	M3x0.5x6	3.74	5.15

Note: Safety cover dimensions may differ for other style hollow shafts.

Figure 5.9 Frame Size 1100

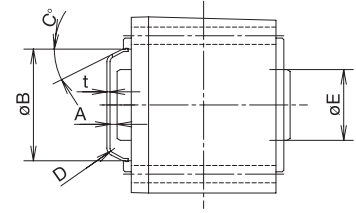
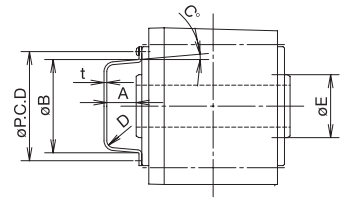

Figure 5.10 Frame Sizes 1200 ~1600



Torque Arm

Figure 5.16 Recommended Dimensions for customer designed torque arms

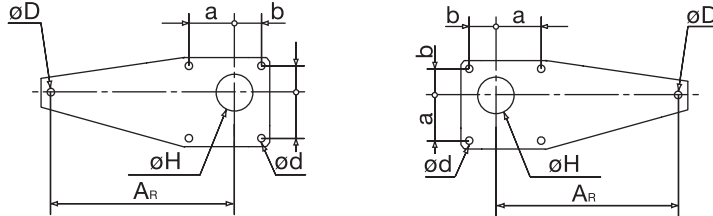

Table 5.17 Hyponic® Torque Arm Recommended Dimensions (in.)^[1]

Model	Length	Bore	Stop Hole	Mounting Pitch		Mounting Hole	Thickness
	AR	øH	øD	a	b	ød	
1120	3.15	2.13	0.35	1.65	1.26	0.28	0.13
1220	3.94	3.15	0.43	2.24	1.57	0.35	0.18
1230	3.94	3.15	0.35	2.56	1.57	0.35	0.24
1320	4.72	3.43	0.55	2.44	1.81	0.43	0.18
1330, 1340	5.12	3.43	0.43	3.11	1.85	0.43	0.35
1420	5.51	3.82	0.71	2.95	2.24	0.55	0.24
1430, 1440	6.30	3.82	0.55	3.62	2.13	0.55	0.35
1520, 1521, 1522	5.91	4.41	0.87	3.15	2.76	0.55	0.35
1530, 1531, 1540	7.87	4.41	0.71	4.29	2.52	0.71	0.35
1630, 1631, 1632, 1633, 1640	11.02	5.98	0.87	5.71	3.35	0.87	0.47

Note 1: These dimensions do not correspond to Sumitomo designed torque arms

Accessories Torque Arm continued

Figure 5.12 Hyponic® Torque Arm Mounting Examples

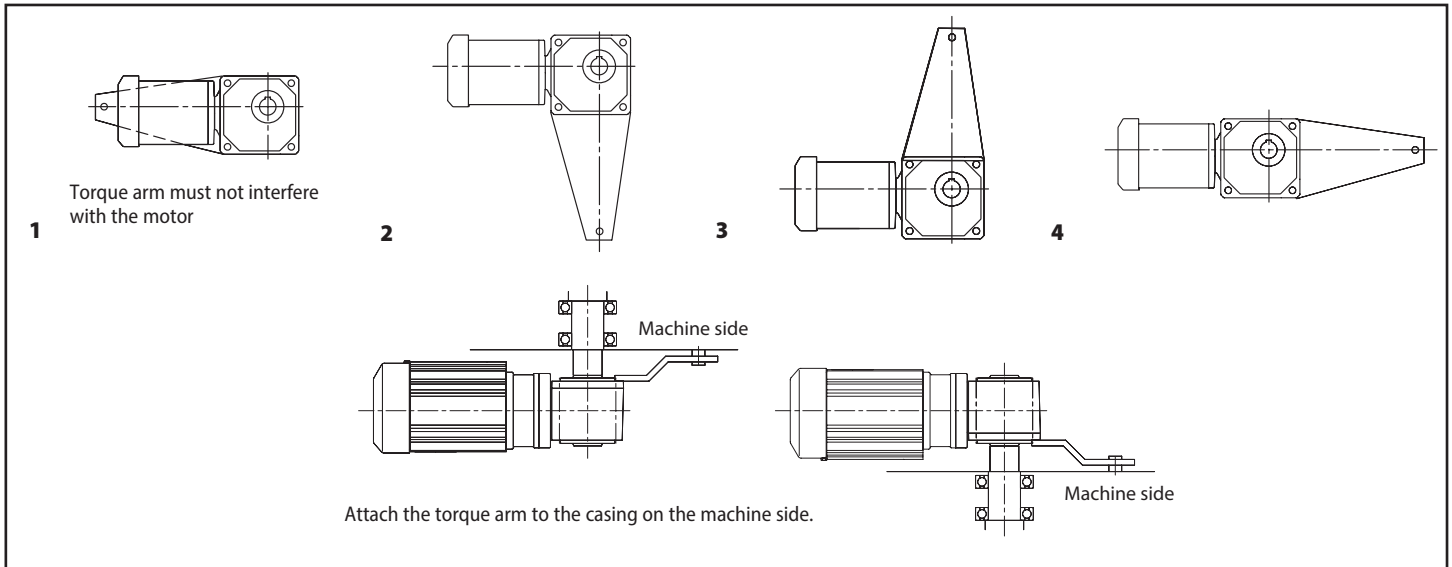

Accessories Torque Arm continued

Torque Arm Mounting:

1. Attach the torque arm to the Hyponic® casing on the machine side using hex socket head cap screws. Refer to Table 5.18 for bolt sizes.
2. Leave some clearance between the torque arm and machine, and the torque arm and mounting bolt, so excessive force will not be applied to the Hyponic® and driven shaft. **3.** For frequent start/stop applications, or repeated normal/reverse operations, use a rubber bushing between the torque arm and mounting bolt (or spacer) to absorb the shock.

Table 5.18 Torque Arm Bolt Sizes

Model	Bolt
1120, 1230	M8
1220, 1330, 1340	M10
1320, 1430, 1440	M12
1420, 1530, 1531	M16
1520, 1521, 1522, 1630, 1631, 1632, 1633, 1640	M20

Figure 5.13 Hyponic® Torque Arm Clearance

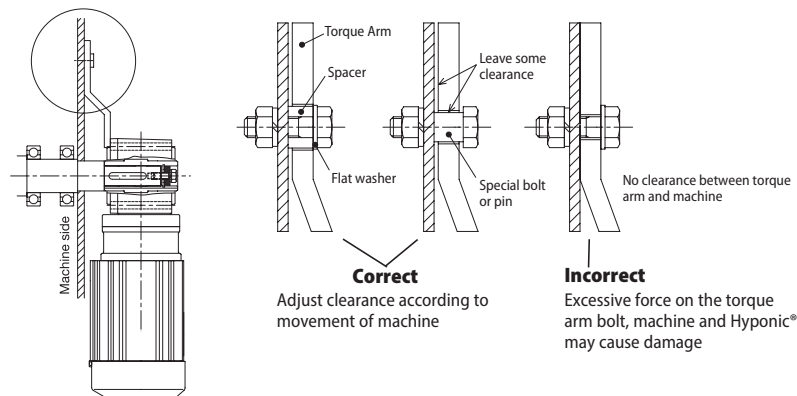

Lubrication

Hyponic® drives are filled with long-life grease and sealed, so replenishment is unnecessary, but overhaul in approximately 20,000 hours or three to five years of operation will provide longer service life. Operating conditions affect oil seal durability. Under severe conditions, they may require changing in less than 20,000 hours or three years of operation. Gearmotors must be overhauled at factory-authorized locations.

Table 5.19 Hyponic Greases

Grease	Description	Temperature Range
Nihon Koyu BA-11A	Standard Grease	14°F to 104°F (-10°C to 40°C)
Nihon Koyu BH-17B	Low Temperature Grease	-22°F to 14°F (-30°C to -10°C)
Cassida-SGG 000	Food Grade Grease	14°F to 104°F (-10°C to 40°C)

Hyponic®

Technical Information

Paint and Rust-proofing Specifications

Table 5.20 Paint Specifications

Paint Classification	Coating Name	Paint Color	Resin Type	Dry Time (hrs.)
Food and Beverage Industry Antimicrobial Powder Coating (standard)	Dupont Alesta	Silver Freeze	TGIC-Polyester	–
SMA Blue Paint (optional)	DTM Water-Based Enamel	Blue	Water-Based Acrylic Polymer	1 – 1½
Epoxy (optional)	Heavy-Duty Epoxy	Blue	Polymide Converted Epoxy	4 – 6
FDA-USDA (optional)	Food and Beverage Industry Coating	High Gloss White or Silver	Modified Alkyd	4 – 7

- All completely assembled models receive rust-proofing treatment prior to shipment.
- All models for export receive rust-proofing treatment that is effective for 12 months. Please specify "export Rust-proofing" for all export models.
- Please consult factory for storage longer than those listed in Table 5.21 or in the event of adverse storage conditions.

Table 5.21 Rust-proofing Specifications

Rust-Proofing Period	1 Year
Storage Condition	Indoor environment that is relatively free of humidity, dust, extreme temperature fluctuation, corrosive gas, etc.

North American Motor Specifications

Feature	All Motors
Motor Type	3-Phase AC Asynchronous Squirrel Cage Induction Motor
Motor Standard	NEMA
Power Range	1/8 through 15 HP (0.1 through 11 kW)
Number of Poles	4 Poles
Motor Power Supply	230 / 460 Volts, 60 Hz, 3 phase 575 Volts, 60 Hz, 3 phase
Synchronous RPM (Slip)	1800 RPM (20 - 100 RPM - See Motor Nameplate)
NEMA Design	A or B (See Motor Nameplate)
Efficiency	1/8 through 3/4 HP (Standard Efficiency - IE1) 1 through 15 HP (Premium Efficiency - IE3)
Motor Temperature Rise	Class B
Motor Insulation	Class F Tropicalized
Service Factor	Sinusoidal Utility Power: 1.15, Inverter Power: 1.0
Time Rating	Continuous
Frame Material	Diecast Aluminum
Enclosure Type	1/8 HP - TENV, 1/4 HP - 15 HP - TEFC
Enclosure Rating	IP55 Outdoor and Indoor Neoprene v-ring, gaskets and slinger shaft seals
Conduit Box	Outdoor Gasketed Oversized Diecast Aluminum, NPT Conduit Thread (Optional Indoor Steel)
Certification	UL Recognition, CSA Certification, CE Marked
Inverter Compatibility	Motor Insulation MG1 Part 31 Compliant
Constant Torque Speed Range	See Below
Overspeed Operation	Up to 120 Hz Check Reducer and Driven Equipment Overspeed Rating!
Motor Bearings	Double shielded, Deep Groove, Sealed for Life, CM Reduced Clearance Ball Bearings
Fan Guard (TEFC)	Steel
Fan (TEFC)	1/8 - 3/4 HP (PBT) 1 - 15 HP (Nylon Resin - PA66 with 30% Glass Fiber)
Lifting Provisions	(1 - 15 HP) Eyebolt

Hyponic®

Technical Information

Feature	Non-Brake Motor	Brake Motor
Constant Torque Speed Range	See page 3.8 for table.	See page 3.8 for table.
208V Motor Power	Usable on 208V Network	Motor usable on 208V network but supply 230V for brake control
Brake Power Supply	-----	230 / 460 Volts, 60 Hz, 1 phase 575 Volts, 60 Hz, 1 phase
Brake Insulation	-----	Class F
Manual Brake Release Mechanism	-----	1/8 - 1/2 HP - no release mechanism 3/4 - 15 HP - one-touch lever type release

Motor

Conduit Box Mounting Direction

The conduit box mounting direction may be changed in 90° increments. A mounting direction other than standard must be specified when an order is placed and changed by the factory. When ordering, refer to Figure 5.14 for lead wire opening direction and mounting direction. The direction cannot be changed after shipment.

Figure 5.14 Conduit Box Mounting Direction – Three-Phase (Standard Motor and Inverter) and Single-Phase

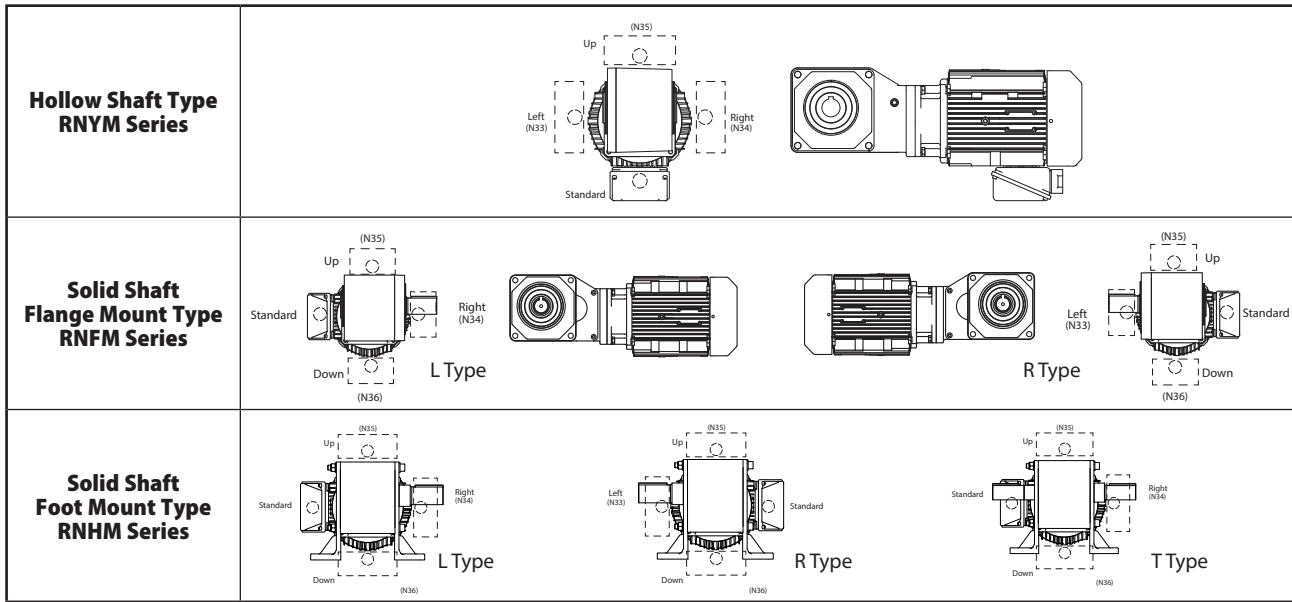

Motor Installation: Fan/Brake Cover Clearance Requirements

Required gearmotor clearance dimension FA and FB for installation to achieve best performance and proper maintenance.

Dimension FA: Clearance necessary to remove fan cover or brake cover without moving the gearmotor.

Dimension FB: Minimum clearance to provide adequate airflow for ventilating the motor.

Notes: 1. In some cases, it may be necessary to move the gearmotor to remove the fan cover or brake cover.

Figure 5.15 Motor End Clearance

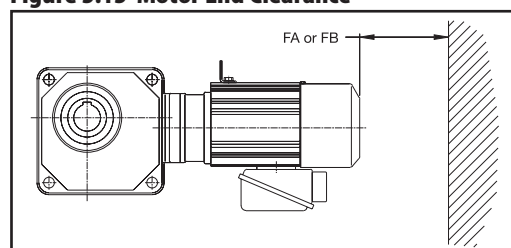

Table 5.22a Motor Clearance Requirements for Standard IE1 motors (1/8 to 3/4 hp)

inch (mm)

IE1 Motor			Standard 3-Phase Motor		3-Phase With Brake Motor	
Frame Size	HP x Pole	kW x Pole	FA	FB	FA	FB
V-63S	1/8 x 4	0.1 x 4	-	-	2.0 (49)	-
V-63M	1/4 x 4	0.2 x 4	1.9 (48)	0.8 (20)	2.5 (61)	0.8 (20)
V-63M	1/3 x 4	0.25 x 4				
V-71M	1/2 x 4	0.4 x 4	1.9 (48)	0.8 (20)	2.5 (61)	0.8 (20)
V-80S	3/4 x 4	0.55 x 4	2.0 (49)	0.8 (20)	3.7 (93)	0.8 (20)

Table 5.22b Motor Clearance Requirements for AF - motors (1/8 to 3/4 hp)

inch (mm)

IE1 Motor			Standard 3-Phase Motor		3-Phase With Brake Motor	
Frame Size	HP x Pole	kW x Pole	FA	FB	FA	FB
VA-63S	1/8 x 4	0.1 x 4				
VA-63M	1/4 x 4	0.2 x 4	1.9 (48)	0.8 (20)	2.5 (61)	0.8 (20)
VA-63M	1/3 x 4	0.25 x 4				
VA-71M	1/2 x 4	0.4 x 4	2.0 (49)	0.8 (20)	3.7 (93)	0.8 (20)
VA-80S	3/4 x 4	0.55 x 4	2.1 (52)	0.8 (20)	4.6 (115)	0.8 (20)

Table 5.22c Motor Clearance Requirements for EP motors (1 to 15 hp)

inch (mm)

IE3 Motor			3-Phase Without Brake Motor		3-Phase Brake (B) Motor	
Frame Size	HP x Pole	kW x Pole	FA	FB	FA	FB
N-80M	1 x 4	0.75 x 4	2.3 (58)	0.8 (20)	4.8 (122)	0.8 (20)
N-90S	1.5 x 4	1.1 x 4	2.3 (59)	0.8 (20)	5.0 (128)	0.8 (20)
N-90L	2 x 4	1.5 x 4				
N-100L	3 x 4	2.2 x 4	2.4 (60)	0.8 (20)	5.4 (138)	0.8 (20)
N-112M	5 x 4	3.7 x 4	2.5 (63)	1.0 (25)	6.0 (153)	0.8 (20)
N-132S	7.5 x 4	5.5 x 4				
N-132M	10 x 4	7.5 x 4	3.3 (84)	1.2 (30)	7.4 (189)	1 (25)
N-160M	15 x 4	11 x 4				

Hyponic®

Technical
Information

Motor continued

Motor Conduit Box Details

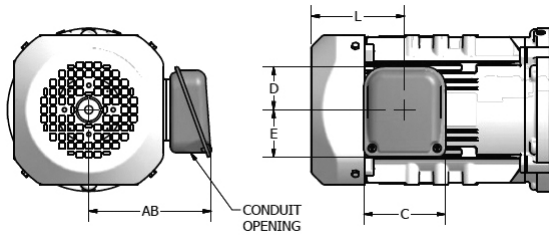

Figure 4.22 Indoor Duty (Optional) Box

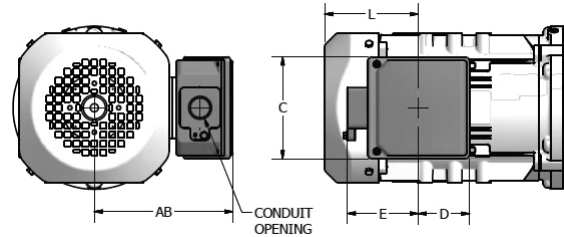

Figure 4.23 Global EP.NA and Outdoor Duty Box

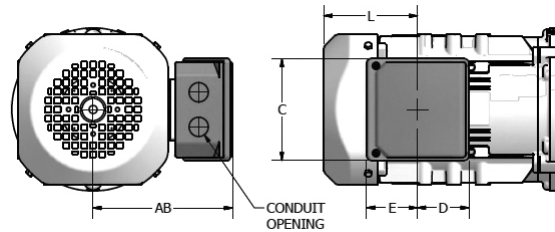

Figure 4.24 Global IE3 CE Box

Table 5.23 Conduit Box Information

inch (mm)

Frame Size	Duty Rating	General Dimensions				Without Brake		With Brake		Conduit Opening	Material
		AB	C	D	E	Availability	L	Availability	L		
V-63S	Indoor Duty (Optional)	4.11 (105)	3.35 (85)	2.09 (53)	1.69 (43)	Yes	1.38 (35)	CF ⁽¹⁾	2.76 (70)	Ø0.90 (Ø23)	Steel
	Indoor Duty Brake (Optional)	4.32 (110)	3.94 (100)	2.29 (58)	2.10 (53)			Yes		Ø0.90 (Ø23)	Steel
	Outdoor Duty (Optional)	4.98 (127)	3.94 (100)	2.42 (62)	2.76 (70)			Yes		NPT1/2 ⁽²⁾	Steel
	Global	4.63 (118)	4.09 (104)	2.24 (57)	2.16 (55)			Yes		NPT1/2	Al Diecast
	Global CE	4.63 (118)	4.09 (104)	2.24 (57)	2.16 (55)			Yes		M16, M25	Al Diecast
VA-63S V-63M VA-63M V-71M	Indoor Duty (Optional)	4.11 (105)	3.35 (85)	2.09 (53)	1.69 (43)	Yes	2.32 (59)	CF ⁽¹⁾	3.58 (91)	Ø0.90 (Ø23)	Steel
	Indoor Duty Brake (Optional)	4.32 (110)	3.94 (100)	2.29 (58)	2.10 (53)			Yes		Ø0.90 (Ø23)	Steel
	Outdoor Duty (Optional)	4.98 (127)	3.94 (100)	2.42 (62)	2.76 (70)			Yes		NPT1/2 ⁽²⁾	Steel
	Global	4.63 (118)	4.09 (104)	2.24 (57)	2.16 (55)			Yes		NPT1/2	Al Diecast
	Global CE	4.63 (118)	4.09 (104)	2.24 (57)	2.16 (55)			Yes		M16, M25	Al Diecast
VA-71M V-80S	Indoor Duty (Optional)	4.69 (119)	3.35 (85)	1.72 (44)	2.04 (52)	Yes	3.82 (97)	CF ⁽¹⁾	5.51 (140)	Ø0.90 (Ø23)	Steel
	Indoor Duty Brake (Optional)	5.68 (144)	4.80 (122)	2.60 (66)	2.84 (72)			Yes		Ø0.90 (Ø23)	Steel
	Outdoor Duty (Optional)	5.55 (141)	3.94 (100)	2.20 (56)	2.95 (75)			Yes		G3/4 ⁽²⁾	Steel
	Global	5.67 (144)	4.92 (125)	2.50 (64)	3.43 (87)			Yes		NPT3/4 ⁽²⁾	Al Diecast
	Global CE	5.71 (145)	4.92 (125)	2.50 (64)	2.47 (63)			Yes		2 - M25	Al Diecast
VA-80S	Indoor Duty (Optional)	4.88 (124)	3.35 (85)	1.72 (44)	2.04 (52)	Yes	3.94 (100)	CF ⁽¹⁾	6.38 (162)	Ø0.90 (Ø23)	Steel
	Indoor Duty Brake (Optional)	5.87 (149)	4.80 (122)	2.60 (66)	2.84 (72)			Yes		Ø0.90 (Ø23)	Steel
	Outdoor Duty (Optional)	5.75 (146)	3.94 (100)	2.20 (56)	2.95 (75)			Yes		G3/4 ⁽²⁾	Steel
	Global	5.86 (149)	4.92 (125)	2.50 (64)	3.43 (87)			Yes		NPT3/4 ⁽²⁾	Al Diecast
	Global CE	5.91 (150)	4.92 (125)	2.50 (64)	2.47 (63)			Yes		2 - M25	Al Diecast

(1) Consult factory for brake configuration supporting this conduit box.

(2) Default thread option shown. Alternate thread options available. Please consult factory for alternate conduit thread options.

Motor continued

Table 5.23 Conduit Box Information (cont.)

inch (mm)

Frame Size	Duty Rating	General Dimensions				Without Brake		With Brake		Conduit Opening	Material
		AB	C	D	E	Availability	L	Availability	L		
N-80M	Indoor Duty (Optional)	4.85 (123)	3.35 (85)	1.72 (44)	2.04 (52)	Yes	3.82 (97)	CF ⁽¹⁾	6.32 (161)	Ø0.90 (Ø23)	Steel
	Indoor Duty Brake (Optional)	5.99 (152)	4.80 (122)	2.60 (66)	2.84 (72)			Yes		Ø0.90 (Ø23)	Steel
	Outdoor Duty (Optional)	5.87 (149)	3.94 (100)	2.20 (56)	2.95 (75)			Yes		G3/4 ⁽²⁾	Steel
	Global EP.NA	5.98 (152)	4.92 (125)	2.50 (64)	3.43 (87)			Yes		NPT3/4 ⁽²⁾	Al Diecast
	Global IE3 CE	6.02 (153)	4.92 (125)	2.50 (64)	2.47 (63)			Yes		2 - M25	Al Diecast
N-90S N-90L	Indoor Duty (Optional)	5.03 (128)	3.35 (85)	1.72 (44)	2.04 (52)	Yes	3.82 (97)	CF ⁽¹⁾	6.56 (167)	Ø0.90 (Ø23)	Steel
	Indoor Duty Brake (Optional)	6.17 (157)	4.80 (122)	2.60 (66)	2.84 (72)			Yes		Ø0.90 (Ø23)	Steel
	Outdoor Duty (Optional)	6.04 (154)	3.94 (100)	2.20 (56)	2.95 (75)			Yes		G3/4 ⁽²⁾	Steel
	Global EP.NA	6.16 (156)	4.92 (125)	2.50 (64)	3.43 (87)			Yes		NPT3/4 ⁽²⁾	Al Diecast
	Global IE3 CE	6.20 (158)	4.92 (125)	2.50 (64)	2.47 (63)			Yes		2 - M25	Al Diecast
N-100L N-112S	Indoor Duty (Optional)	5.93 (151)	3.94 (100)	2.09 (53)	2.29 (58)	Yes	4.53 (115)	CF ⁽¹⁾	7.60 (193)	Ø0.90 (Ø23)	Steel
	Indoor Duty Brake (Optional)	6.72 (171)	4.80 (122)	2.60 (66)	2.84 (72)			Yes		Ø0.90 (Ø23)	Steel
	Outdoor Duty (Optional)	7.21 (183)	4.84 (123)	2.52 (64)	3.43 (87)			Yes		G3/4 ⁽²⁾	Steel
	Global EP.NA	6.71 (170)	4.92 (125)	2.50 (64)	3.43 (87)			Yes		NPT3/4 ⁽²⁾	Al Diecast
	Global IE3 CE	6.75 (172)	4.92 (125)	2.50 (64)	2.47 (63)			Yes		2 - M25	Al Diecast
N-112M	Indoor Duty (Optional)	6.56 (167)	3.94 (100)	2.09 (53)	2.29 (58)	Yes	4.65 (118)	CF ⁽¹⁾	8.21 (209)	Ø0.90 (Ø23)	Steel
	Indoor Duty Brake (Optional)	7.35 (187)	4.80 (122)	2.60 (66)	2.84 (72)			Yes		Ø0.90 (Ø23)	Steel
	Outdoor Duty (Optional)	7.84 (199)	4.84 (123)	2.52 (64)	3.43 (87)			Yes		G3/4 ⁽²⁾	Steel
	Global EP.NA	7.34 (186)	4.92 (125)	2.50 (64)	3.43 (87)			Yes		NPT3/4 ⁽²⁾	Al Diecast
	Global IE3 CE	7.38 (188)	4.92 (125)	2.50 (64)	2.47 (63)			Yes		2 - M25	Al Diecast
N-132S	Indoor Duty (Optional)	6.56 (167)	3.94 (100)	2.09 (53)	2.29 (58)	Yes	4.65 (118)	CF ⁽¹⁾	8.21 (209)	Ø0.90 (Ø23)	Steel
	Indoor Duty Brake (Optional)	7.35 (187)	4.80 (122)	2.60 (66)	2.84 (72)			Yes		Ø0.90 (Ø23)	Steel
	Outdoor Duty (Optional)	7.84 (199)	4.84 (123)	2.52 (64)	3.43 (87)			Yes		G1 ⁽²⁾	Steel
	Global EP.NA	7.34 (186)	4.92 (125)	2.50 (64)	3.43 (87)			Yes		NPT1 ⁽²⁾	Al Diecast
	Global IE3 CE	7.38 (188)	4.92 (125)	2.50 (64)	2.47 (63)			Yes		2 - M25	Al Diecast
N-132M	Indoor Duty (Optional)	7.98 (203)	4.80 (122)	2.60 (66)	2.84 (72)	Yes	5.43 (138)	Yes	9.57 (243)	Ø1.69 (Ø43)	Steel
	Outdoor Duty (Optional)	9.26 (235)	6.06 (154)	3.11 (79)	4.13 (105)					G1 ⁽²⁾	Steel
	Global EP.NA	9.04 (230)	6.69 (170)	3.40 (86)	4.43 (113)					NPT1 ⁽²⁾	Al Diecast
	Global IE3 CE	9.04 (230)	6.69 (170)	3.40 (86)	3.51 (89)					2-M32	Al Diecast
N-160M	Indoor Duty (Optional)	7.98 (203)	4.80 (122)	2.60 (66)	2.84 (72)	Yes	5.43 (138)	Yes	9.57 (243)	Ø1.69 (Ø43)	Steel
	Outdoor Duty (Optional)	9.26 (235)	6.06 (154)	3.11 (79)	4.13 (105)					G1-1/4 ⁽²⁾	Steel
	Global EP.NA	9.04 (230)	6.69 (170)	3.40 (86)	4.43 (113)					NPT1-1/4 ⁽²⁾	Al Diecast
	Global IE3 CE	9.04 (230)	6.69 (170)	3.40 (86)	3.51 (89)					2-M32	Al Diecast

(1) Consult factory for brake configuration supporting this conduit box.

(2) Default thread option shown. Alternate thread options available. Please consult factory for alternate conduit thread options.

Motor continued

Fractional Motor Performance Data - 60Hz Operation

Table 5.24a Standard Three Phase, 230/460V, 60Hz, 1800 RPM Synchronous Speed, TEFC - UL

Motor Capacity		Frame Size	Full Load (A)			Current				Starting Torque % of FL	Breakdown Torque % of FL	Nominal Efficiency %	Power Factor %	NEMA Code Letter
HP	kW		Rated RPM	Torque		Full Load		No Load % of FL	Starting % of FL					
				in-lbs	N-m	230V	460V							
1/8**	0.1	V-63S	1730	4.55	0.514	0.66	0.33	86.1	424	326	308	63.3	60.0	K
1/4	0.2	V-63M	1730	9.10	1.03	1.12	0.56	79.6	464	300	287	69.2	65.1	K
1/3	0.25	V-63M	1700	12.2	1.38	1.24	0.62	72.0	419	237	226	70.1	72.0	G
1/2	0.4	V-71M	1750	18.0	2.03	2.15	1.08	77.7	456	295	276	71.5	65.4	J
3/4	0.55	V-80S	1720	27.5	3.11	2.47	1.24	68.4	500	266	261	76.5	73.1	H

** 1/8 HP is TENV

Table 5.24b Standard Three Phase, 240/480V, 60Hz, 1800 RPM Synchronous Speed, TEFC - UL

Motor Capacity		Frame Size	Full Load (A)			Current				Starting Torque % of FL	Breakdown Torque % of FL	Nominal Efficiency %	Power Factor %	NEMA Code Letter
HP	kW		Rated RPM	Torque		Full Load		No Load % of FL	Starting % of FL					
				in-lbs	N-m	240V	480V							
1/8**	0.1	V-63S	1740	4.53	0.512	0.69	0.35	87.4	429	364	341	61.9	56.3	L
1/4	0.2	V-63M	1740	9.05	1.02	1.16	0.58	83.6	466	335	317	68.2	61	K
1/3	0.25	V-63M	1710	12.3	1.39	1.27	0.63	77.0	429	268	238	69.8	68.1	H
1/2	0.4	V-71M	1750	18.0	2.04	2.27	1.13	83.2	460	328	303	70.4	60.4	K
3/4	0.55	V-80S	1730	27.3	3.09	2.52	1.26	73.4	508	294	285	76.0	69.2	H

** 1/8 HP is TENV

Table 5.24c Non-Standard Three Phase, 230/460V, 60Hz, 1800 RPM Synchronous Speed, TEFC - CSA

Motor Capacity		Frame Size	Full Load (A)			Current				Starting Torque % of FL	Breakdown Torque % of FL	Nominal Efficiency %	Power Factor %	NEMA Code Letter
HP	kW		Rated RPM	Torque		Full Load		No Load % of FL	Starting % of FL					
				in-lbs	N-m	230V	460V							
1/8**	0.1	V-63S	1730	4.55	0.514	0.66	0.33	86.1	424	326	308	63.3	60.0	K
1/4	0.2	V-63M	1730	9.10	1.03	1.12	0.56	79.6	464	300	287	69.2	65.1	K
1/3	0.25	V-63M	1700	12.2	1.38	1.24	0.62	72.0	419	237	226	70.1	72.0	G
1/2	0.4	V-71M	1750	18.0	2.03	2.15	1.08	77.7	456	295	276	71.5	65.4	J
3/4	0.55	V-80S	1720	27.5	3.11	2.47	1.24	68.4	500	266	261	76.5	73.1	H

** 1/8 HP is TENV

Table 5.24d Non-Standard Three Phase, 575V, 60Hz, 1800 RPM Synchronous Speed, TEFC - CSA

Motor Capacity		Frame Size	Full Load (A)			Current				Starting Torque % of FL	Breakdown Torque % of FL	Nominal Efficiency %	Power Factor %	NEMA Code Letter
HP	kW		Rated RPM	Torque		Full Load		No Load % of FL	Starting % of FL					
				in-lbs	N-m	575V								
1/8**	0.1	V-63S	1720	4.58	0.518	0.28		91.8	464	376	391	65.5	54.1	M
1/4	0.2	V-63M	1730	9.10	1.03	0.48		85.4	458	316	340	69.4	60.1	K
1/3	0.25	V-63M	1710	12.2	1.38	0.52		78.8	423	250	270	71.3	67.5	H
1/2	0.4	V-71M	1700	18.5	2.09	0.79		75.8	468	309	300	75.2	63.1	J
3/4	0.55	V-80S	1700	27.8	3.14	1.00		74.0	530	260	268	75.4	71.4	H

** 1/8 HP is TENV

Fractional AF-Motor (AV) Performance Data - 60Hz Operation

Table 5.25a Three Phase, 230/460V, 60Hz, 1800 RPM Synchronous Speed, 10:1 Constant Torque Speed Range TEFC

Motor Capacity		Frame Size	Wiring	Full Load Torque		Voltage V	60 Hz Current Amp	Speed RPM	Voltage V	6 Hz Current Amp	Speed RPM	No Load Current @ 60 Hz
HP	kW			in-lbs	N-m							
1/8	0.1	VA-63S	High Voltage	4.77	0.54	460	0.49	1770	68	0.37	125	0.46
			Low Voltage			230	0.98		34	0.74		0.92
1/4	0.2	VA-63M	High Voltage	9.6	1.08	460	0.91	1765	68	0.79	125	0.87
			Low Voltage			230	1.8		34	1.6		1.74
1/3	0.25	VA-63M	High Voltage	12	1.36	460	0.94	1755	78	0.87	125	0.87
			Low Voltage			230	1.9		34	1.7		1.74
1/2	0.4	VA-71M	High Voltage	19.2	2.17	460	1.3	1750	70	1.1	115	1.21
			Low Voltage			230	2.6		35	2.3		2.42
3/4	0.55	VA-80S	High Voltage	26.3	2.97	460	1.7	1760	62	1.6	125	1.54
			Low Voltage			230	3.3		31	3.1		3.07

Table 5.25b Three Phase, 230/460V, 60Hz, 1800 RPM Synchronous Speed, 10:1 Constant Torque Speed Range TEFC - CSA

Motor Capacity		Frame Size	Wiring	Full Load Torque		Voltage V	60 Hz Current Amp	Speed RPM	Voltage V	6 Hz Current Amp	Speed RPM	No Load Current @ 60 Hz
HP	kW			in-lbs	N-m							
1/8	0.1	VA-63S	High Voltage	4.77	0.54	460	0.49	1770	68	0.37	125	0.46
			Low Voltage			230	0.98		34	0.74		0.92
1/4	0.2	VA-63M	High Voltage	9.57	1.08	460	0.91	1765	68	0.79	125	0.87
			Low Voltage			230	1.8		34	1.6		1.74
1/3	0.25	VA-63M	High Voltage	12.0	1.36	460	0.94	1755	78	0.87	125	0.87
			Low Voltage			230	1.9		34	1.7		1.74
1/2	0.4	VA-71M	High Voltage	19.3	2.17	460	1.3	1750	70	1.1	115	1.21
			Low Voltage			230	2.6		35	2.3		2.42
3/4	0.55	VA-90S	High Voltage	26.3	2.97	460	1.7	1765	62	1.5	145	1.54
			Low Voltage			230	3.3		31	2.9		3.08

Table 5.25c Three Phase, 575V, 60Hz, 1800 RPM Synchronous Speed, 10:1 Constant Torque Speed Range TEFC - CSA Approved

Motor Capacity		Frame Size	Full Load Torque		Voltage V	60 Hz Current Amp	Speed RPM	Voltage V	6 Hz Current Amp	Speed RPM	No Load Current @ 60 Hz
HP	kW		in-lbs	N-m							
1/8	0.1	VA-63S	4.77	0.54	575	0.4	1770	85	0.3	130	0.4
1/4	0.2	VA-63M	9.57	1.08	575	0.7	1765	77	0.5	85	0.62
1/3	0.25	VA-63M	12.0	1.36	575	0.7	1755	95	0.7	120	0.62
1/2	0.4	VA-71M	19.4	2.17	575	0.94	1745	88	0.86	110	0.86
3/4	0.55	VA-90S	26.3	2.97	575	1.3	1765	76	1.1	140	0.98

Hyponic®

Technical Information

Motor continued

Motor Performance Data - Small kW CE Motor, 50Hz Operation

Table 5.26a IE1 Three Phase, 220/380V, 50Hz, 1500 RPM Synchronous Speed, TEFC - CE

(Not for EU or UK)

Motor Capacity		Frame Size	Full Load (A)			Current				Starting Torque % of FL	Breakdown Torque % of FL	Nominal Efficiency %	Power Factor %	NEMA Code Letter
HP	kW		Rated RPM	Torque		Full Load		No Load % of FL	Starting % of FL					
				in-lbs	N-m	220V	380V							
1/8**	0.1	V-63S	1400	6.03	0.682	0.6	0.35	78.3	371	230	226	63.3	69.1	H
1/4	0.2	V-63M	1390	12.2	1.37	1.05	0.61	71.5	361	206	206	67.6	73.7	F
1/3	0.25	V-63M	1360	15.5	1.75	1.22	0.71	61.4	338	195	181	69.1	77.8	E
1/2	0.4	V-71M	1410	24.0	2.71	2.06	1.19	68.3	353	201	204	69.7	73.5	F
3/4	0.55	V-80S	1400	33.2	3.75	2.45	1.42	58.5	373	206	196	73.4	80.2	E

** 1/8 HP is TENV

Table 5.26b IE1 Three Phase, 230/400V, 50Hz, 1500 RPM Synchronous Speed, TEFC - CE

(Not for EU or UK)

Motor Capacity		Frame Size	Full Load (A)			Current				Starting Torque % of FL	Breakdown Torque % of FL	Nominal Efficiency %	Power Factor %	NEMA Code Letter
HP	kW		Rated RPM	Torque		Full Load		No Load % of FL	Starting % of FL					
				in-lbs	N-m	230V	400V							
1/8**	0.1	V-63S	1420	5.95	0.672	0.62	0.36	83.6	361	261	255	62.1	64.9	H
1/4	0.2	V-63M	1410	12.0	1.35	1.08	0.62	77.3	371	236	233	67.1	69.5	G
1/3	0.25	V-63M	1380	15.3	1.73	1.22	0.7	68.4	371	225	205	69.4	74.2	F
1/2	0.4	V-71M	1420	23.8	2.69	2.13	1.23	75.6	366	229	229	68.5	68.7	G
3/4	0.55	V-80S	1410	32.9	3.72	2.45	1.41	65.2	390	225	219	73.6	76.7	F

** 1/8 HP is TENV

Table 5.26c IE1 Three Phase, 240/415V, 50Hz, 1500 RPM Synchronous Speed, TEFC - CE

(Not for EU or UK)

Motor Capacity		Frame Size	Full Load (A)			Current				Starting Torque % of FL	Breakdown Torque % of FL	Nominal Efficiency %	Power Factor %	NEMA Code Letter
HP	kW		Rated RPM	Torque		Full Load		No Load % of FL	Starting % of FL					
				in-lbs	N-m	240V	415V							
1/8**	0.1	V-63S	1420	5.95	0.672	0.65	0.37	88.1	378	286	277	60.9	60.9	J
1/4	0.2	V-63M	1410	12.0	1.35	1.1	0.64	80.9	375	260	253	66.4	65.7	H
1/3	0.25	V-63M	1390	15.2	1.72	1.23	0.71	73.0	380	247	223	69.5	70.6	G
1/2	0.4	V-71M	1430	23.6	2.67	2.23	1.29	80.6	364	250	247	67.0	64.4	H
3/4	0.55	V-80S	1420	32.7	3.7	2.46	1.43	70.6	413	248	237	73.6	73.1	G

** 1/8 HP is TENV

Table 5.26d IE3 Three Phase, 230/400V, 50Hz, 1500 RPM Synchronous Speed, 6 lead, CE Marked, TEFC

(for EU or UK)

Motor Capacity		Frame Size	Full Load Ratings							Current as % Full Load		Torque as % of Full Load	
HP	kW		Current		RPM	Torque		Nominal Efficiency	Power Factor	No Load	Starting	Starting	Breakdown
			230V	400V		N-m	in-lbs						
1/8**	0.1**	V-63S	0.62	0.35	1420	0.672	5.95	62.1	0.65	83.6	361	261	255
1/8	0.12	VA-63S	0.7	0.41	1430	0.8	7.08	72.5	0.59	84.3	571	283	346
1/4	0.2	VA-63M	1.08	0.63	1410	1.35	11.95	76.5	0.60	77.8	565	277	331
1/3	0.25	VA-63M	1.19	0.69	1400	1.71	15.13	76.1	0.69	70.6	513	219	262
1/2	0.4	VA-71M	1.86	1.08	1420	2.68	23.72	79.1	0.68	72.6	559	311	362
3/4	0.55	N-80S	2.31	1.33	1430	3.66	32.39	83.5	0.71	36.4	647	293	365

** 0.1 kW (1/8 HP) is TENV and IE1

Motor Performance Data - EP.NA Motor, 60Hz Operation

Table 5.27 Three Phase, 230/460v, 60Hz, 1800 RPM Synchronous Speed, TEFC

Units: inches (mm)

Motor Power HP (kW)		Frame Size	Full Load			Current (A)				Starting Torque % of FL	Breakdown Torque % of FL	Nominal Efficiency %	Power Factor %	NEMA Code Letter
			Rated RPM	Torque		Full Load		No Load % of FL	Starting % of FL					
HP	kW			in-lbs	N-m	230V	460V							
1	0.75	N-80M	1730	36.6	4.14	3.06	1.53	62.0	692	343	403	85.5	72.0	K
1.5	1.1	N-90S	1730	53.7	6.07	4.15	2.08	52.1	659	277	341	86.5	76.5	J
2	1.5	N-90L	1730	73.2	8.28	5.61	2.80	52.7	694	284	356	86.5	77.2	J
3	2.2	N-100L	1740	107	12.1	7.66	3.83	47.5	824	317	389	89.5	80.7	K
5	3.7	N-112M	1750	179	20.2	12.3	6.17	44.5	821	244	379	89.5	83.9	K
7.5	5.5	N-132S	1760	264	29.8	17.8	8.90	42.9	1000	290	461	91.7	84.2	L
10	7.5	N-132M	1760	360	40.7	24.4	12.2	36.1	606	193	277	91.7	84.1	G
15	11	N-160M	1770	525	59.3	38.4	19.2	48.0	736	274	369	92.4	77.8	J

Table 5.28 Three Phase, 240/480V, 60Hz, 1800 RPM Synchronous Speed, TEFC

Units: inches (mm)

Motor Power HP (kW)		Frame Size	Full Load			Current (A)				Starting Torque % of FL	Breakdown Torque % of FL	Nominal Efficiency %	Power Factor %	NEMA Code Letter
			Rated RPM	Torque		Full Load		No Load % of FL	Starting % of FL					
HP	kW			in-lbs	N-m	240V	480V							
1	0.75	N-80M	1740	36.4	4.12	3.05	1.52	66.2	723	380	439	85.5	69.2	L
1.5	1.1	N-90S	1740	53.4	6.04	4.09	2.05	56.6	704	310	375	86.5	74.1	J
2	1.5	N-90L	1730	73.2	8.28	5.54	2.77	57.8	722	316	387	86.5	74.5	K
3	2.2	N-100L	1750	106	12.0	7.53	3.77	52.1	911	352	446	89.5	78.4	L
5	3.7	N-112M	1760	178	20.1	12.1	6.06	49.3	886	268	421	89.5	81.7	K
7.5	5.5	N-132S	1760	264	29.8	17.5	8.76	47.6	1060	321	506	91.7	82.0	M
10	7.5	N-132M	1760	360	40.7	23.8	11.9	40.3	652	212	308	91.7	82.2	H
15	11	N-160M	1770	525	59.3	38.7	19.3	54.0	760	305	405	92.4	74.0	K

Hyponic®

Technical
Information

Motor continued

Motor Performance Data - EP.NA Motor, 60Hz Operation (continued)

Table 5.29 Three Phase, 575V, 60Hz, 1800 RPM Synchronous Speed, TEFC

Units: inches (mm)

Motor Power HP (kW)		Frame Size	Full Load			Current (A)			Starting Torque % of FL	Breakdown Torque % of FL	Nominal Efficiency %	Power Factor %	NEMA Code Letter
HP	kW		Rated RPM	Torque		Full Load 575V	No Load % of FL	Starting % of FL					
				in-lbs	N-m								
1	0.75	N-80M	1740	36.4	4.12	1.36	72.7	768	430	500	85.5	64.4	M
1.5	1.1	N-90S	1740	53.4	6.04	1.69	57.8	743	313	386	86.5	74.5	K
2	1.5	N-90L	1730	73.2	8.28	2.22	52.3	685	272	341	86.5	77.9	J
3	2.2	N-100L	1740	107	12.1	3.05	47.2	839	322	404	89.5	80.8	K
5	3.7	N-112M	1750	179	20.2	4.86	42.0	798	230	355	89.5	84.9	J
7.5	5.5	N-132S	1760	264	29.8	7.12	42.5	957	263	429	91.7	84.7	L
10	7.5	N-132M	1760	360	40.7	10.1	43.9	704	230	332	91.7	81.3	H
15	11	N-160M	1760	528	59.7	14.5	41.7	710	237	331	92.4	82.3	H

Motor continued

Motor Performance Data - IE3 CE Motor, 50Hz Operation

Table 5.30 Three Phase, 220/380V, 50Hz, 1800 RPM Synchronous Speed, TEFC

Units: inches (mm)

Motor Power HP (kW)		Frame Size	Full Load			Current (A)				Starting Torque % of FL	Breakdown Torque % of FL	Nominal Efficiency %	Power Factor %	NEMA Code Letter
HP	kW		Rated RPM	Torque		Full Load		No Load % of FL	Starting % of FL					
				in-lbs	N-m	220V	380V							
1	0.75	N-80M	1430	44.3	5.01	3.46	2.00	66.2	579	383	402	84.7	67.9	K
1.5	1.1	N-90S	1430	65.0	7.35	4.49	2.59	54.4	606	296	343	85.4	75.1	J
2	1.5	N-90L	1420	89.2	10.1	6.10	3.52	54.9	578	304	338	85.4	75.5	H
3	2.2	N-100L	1440	129	14.6	8.58	4.96	52.2	758	344	418	88.6	78.0	K
4	3.0	N-112S	1430	177	20.0	11.3	6.50	45.6	676	316	365	87.7	80.8	J
5	3.7	N-112M	1460	214	24.2	13.5	7.80	48.5	743	266	378	89.6	81.2	J
5.5	4.0	N-112M	1450	233	26.3	14.4	8.30	45.2	692	266	378	88.9	82.9	J
7.5	5.5	N-132S	1460	318	36.0	-	11.5	49.6	907	316	471	90.6	80.7	L
10	7.5	N-132M	1460	434	49.1	-	15.8	44.9	590	213	315	90.8	79.6	H
15	11	N-160M	1460	636	71.9	-	22.3	38.5	551	200	283	91.4	81.6	G

Table 5.31 Three Phase, 230/400V, 50Hz, 1800 RPM Synchronous Speed, TEFC

Units: inches (mm)

Motor Power HP (kW)		Frame Size	Full Load			Current (A)				Starting Torque % of FL	Breakdown Torque % of FL	Nominal Efficiency %	Power Factor %	NEMA Code Letter
HP	kW		Rated RPM	Torque		Full Load		No Load % of FL	Starting % of FL					
				in-lbs	N-m	230V	400V							
1	0.75	N-80M	1440	44.0	4.97	3.54	2.05	72.3	613	423	446	84.6	62.7	L
1.5	1.1	N-90S	1440	64.5	7.29	4.50	2.60	61.4	640	336	387	85.6	71.1	K
2	1.5	N-90L	1430	88.6	10.0	6.17	3.56	62.2	601	338	375	85.8	72.3	J
3	2.2	N-100L	1450	128	14.5	8.56	4.95	60.2	798	382	465	88.7	74.1	L
4	3.0	N-112S	1440	176	19.9	11.2	6.45	53.2	727	352	419	87.9	76.9	K
5	3.7	N-112M	1460	214	24.2	13.7	7.90	56.0	766	294	420	89.0	77.5	K
5.5	4.0	N-112M	1460	231	26.2	14.4	8.30	53.4	733	273	388	89.1	78.8	K
7.5	5.5	N-132S	1460	318	36.0	-	11.6	56.6	937	351	524	90.6	76.2	M
10	7.5	N-132M	1460	434	49.1	-	16.0	51.9	704	206	350	91.2	75.5	K
15	11	N-160M	1470	632	71.5	-	22.2	54.4	635	257	378	91.5	73.0	J

Hyponic®

Technical
Information

Motor continued

Motor Performance Data - EP.NA Motor, 60Hz Operation (continued)

Table 5.32 Three Phase, 240/415V, 50Hz, 1800 RPM Synchronous Speed, TEFC

Units: inches (mm)

Motor Power HP (kW)		Frame Size	Full Load			Current (A)				Starting Torque % of FL	Breakdown Torque % of FL	Nominal Efficiency %	Power Factor %	NEMA Code Letter
			Rated RPM	Torque		Full Load		No Load % of FL	Starting % of FL					
HP	kW			in-lbs	N-m	240V	415V							
1	0.75	N-80M	1450	43.7	4.94	3.65	2.11	76.3	600	461	484	84.1	59.4	L
1.5	1.1	N-90S	1440	64.5	7.29	4.57	2.64	66.3	654	368	422	85.5	67.4	K
2	1.5	N-90L	1440	88.0	9.95	6.29	3.63	68.7	611	366	406	85.4	67.3	K
3	2.2	N-100L	1450	128	14.5	8.83	5.10	66.1	805	412	502	88.3	69.3	M
4	3.0	N-112S	1440	176	19.9	11.3	6.55	59.8	751	387	458	87.9	73.2	L
5	3.7	N-112M	1460	214	24.2	13.9	8.00	62.5	788	319	453	89.2	72.7	L
5.5	4.0	N-112M	1460	231	26.2	14.5	8.35	59.7	752	294	418	89.0	74.8	K
7.5	5.5	N-132S	1470	316	35.7	-	11.9	64.1	958	378	564	90.2	72.0	N
10	7.5	N-132M	1470	431	48.7	-	16.2	58.5	629	254	378	90.6	71.1	J
15	11	N-160M	1470	632	71.5	-	22.4	50.6	617	249	354	91.6	74.6	H

Motor Selection Considerations for Inverter (VFD) Operation

Benefits:

Operating a three-phase AC Motor with an Inverter (Variable Frequency Drive – VFD) brings benefits to the design of a process control system:

- Extending a motor's acceleration time (soft starting) can greatly reduce motor starting current levels. Inrush current is limited typically to 150% of a motor's ampere ratings.
- Controlled and extended acceleration and deceleration rates reduce or eliminate the stress of high torque demands on the motor, reducer and driven load.
- Motor speed can be infinitely adjusted electronically to operate the process at the optimum speed.
- Full-rated motor torque levels can be applied to the load over as much as a 10:1 speed range (6 to 60 Hz, approximately 180 to 1800 RPM motor shaft speed). *(See note on next page about Constant Torque Speed Range)*
- Overspeed operation: within the operating limits of the motor, reducer and driven load, motor speed range can be extended beyond 60 Hz (1800 RPM). *(See note on next page about Constant Horsepower Speed Range)*
- Regulation of motor speed and/or torque without additional feedback devices.
- A properly sized and adjusted Sensorless Flux Vector AC drive can regulate motor shaft speed to almost eliminate motor slip over the motor's entire loading range.
- Electronic programmable motor torque limiting.
- Electronic overload and short circuit protection for the motor.
- Electronic Reversing: upon command, a VFD will follow preprogrammed deceleration rate to stop motor and then follow acceleration rate to bring motor to commanded speed in reverse direction. No additional power or mechanical components needed to reverse the motor.
- Motor braking (up to 150% of motor rated torque level with optional VFD components).
NOTE: VFDs do not provide HOLDING brake capability. VFDs can be used to sequence a motor-mounted holding brake.
- Many VFDs include basic process control functions and easily interface with Programmable Logic Controllers for more advance process control schemes.
- Serial communication capability for remote monitoring of motor, VFD and process status.
- Within a small limited HP range, VFDs can be selected to power a three-phase 230V motor from a single phase 240V power feed.

Constant Torque Operation:

For most gearmotor applications, a constant-torque rated VFD is required.

Constant-torque rated VFDs carry various manufacturer designations:

- Constant Torque, Heavy Duty or Normal Duty.

All constant-torque rated VFDs carry a 60-second ampere overload capability level of 150% of the VFD's continuous output ampere rating.

VFDs that offer a 110% or 120% 60-second ampere overload capability are designed for variable-torque type loads like fans and pumps with propellers and impellers and are most likely undersized for gearmotor applications.

When a VFD applies power to a motor, it simultaneously varies both the applied motor voltage level (amplitude) and the motor frequency (Hz) so that the torque delivered at the motor shaft can be held constant from a motor's base speed (typically 60 Hz) down to below 20 Hz.

The lower frequency limit is dependent on the design complexity of the VFD:

Basic V/Hz control (6 Hz), Sensorless Vector control (0.6 Hz), full Flux Vector control (0.06 Hz).

To achieve the Vector levels of motor control, the VFD must control only one motor, the VFD and motor must be closely matched in power ratings and the VFD must be properly adjusted, perhaps even "tuned" to the motor.

Most electrical motors are not designed to operate continuously at such low frequencies.

(See note on next page about Constant Torque Speed Range)

Motor continued

Motor Selection Considerations for Inverter (VFD) Operation (cont.)

Constant Horsepower (CHP) Operation:

It may be possible to configure a VFD to operate a motor at speeds beyond the motor's base frequency (typically 60 Hz – 1800 RPM).

To avoid unsafe and unreliable operation, never power a motor, reducer or a driven load beyond the manufacturer's maximum safe operating speed.

See "Motor Specifications" on page (5.15) for the Sumitomo motor maximum operating speed rating. Consult Sumitomo factory for the Hyponic reducer maximum operating speed rating. Consult the manufacturer of the driven load for its maximum operating speed rating.

A motor's full-load power rating is the product of its full-load torque rating and its base speed rating. A motor's power rating does not increase when it is operated above its base speed.

Operation above a motor's base frequency is called Constant Horsepower (CHP) operation. When a motor is operated above its base frequency, its output torque capability drops as its frequency is increased.

Constant Torque Speed Range (CTSR):

Most motors are not designed to operate for prolonged periods of time at low speed (typically below 20 Hz).

Most motors (i.e TEFC) depend upon a motor shaft-mounted fan for ventilation.

When the motor is operating at low speed, this motor shaft-mounted fan does not provide sufficient air movement to keep the motor's internal temperature within proper operating limits.

Operating a motor continuously beyond its CTSR can result in premature motor failure. Be sure to properly configure the VFD's motor overload protection to match the motor type.

Motors listed for control by a VFD at low speed have been specifically designed to dissipate the heat through means other than the motor shaft-mounted fan.

A motor's ability to operate continuously at low speed is defined by its CTSR or Constant Torque Speed Range.

Examples of a CTSR rating are: 4:1, 6:1, 10:1.

A motor with a CTSR rating of 4:1 can operate continuously at 15 Hz ($60 \text{ Hz} / 4 = 15 \text{ Hz}$).

A motor with a CTSR rating of 10:1 can operate continuously at 6 Hz ($60 \text{ Hz} / 10 = 6 \text{ Hz}$).

See "Constant Torque Speed Ranges: Gearmotors" on page 3.8 for the Sumitomo motor constant torque speed rating (CTSR).

Consult the instructional material supplied with the VFD for additional important information.

Standard Wiring Diagrams

Illustrated below are the wiring diagrams for our standard motors. For additional information please refer to the motor name plate. Due to changes in design features, this diagram may not always agree with that on the motor. If different, the motor diagram found inside the conduit box cover should be used.

Three-Phase EP.NA Motor

Table 5.33 Wiring Configuration for 230/460V, 60Hz and 575V, 60Hz by EP.NA Motor

Motor HP x P	230/460V, 60Hz			575V, 60Hz		
	Internal	No. of Leads	Diagram	Internal	No. of Leads	Diagram
1 x 4	WYE	9	9-Lead WYE	WYE	3	3-Lead
1.5 x 4						
2 x 4						
3 x 4						
5 x 4						
7.5 x 4	DELTA	9	9-Lead DELTA	DELTA	3	3-Lead
10 x 4						
15 x 4						
20 x 4						
25 x 4						
30 x 4						
40 x 4						
50 x 4						
60 x 4						
75 x 4						

Figure 5.25 EP.NA - WYE

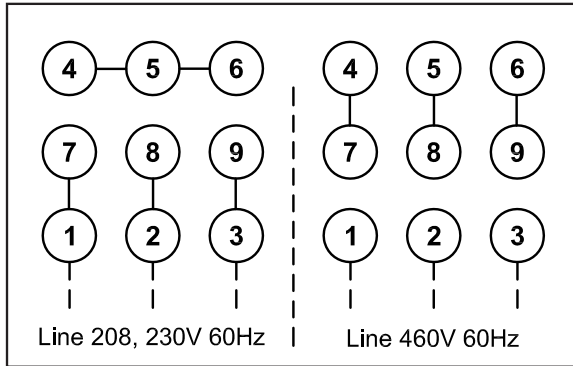

Figure 5.26 EP.NA - DELTA

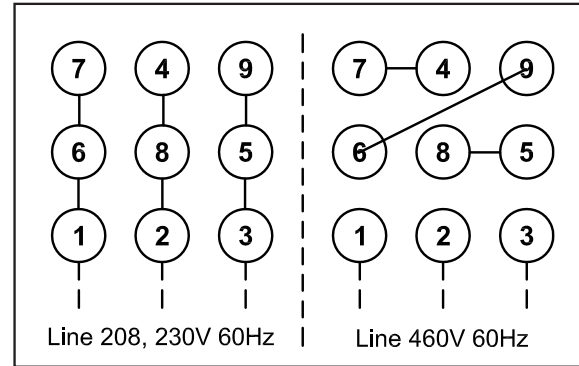
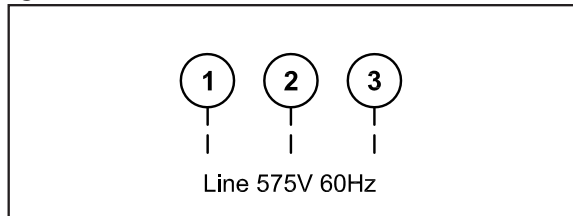

Figure 5.27 EP.NA - SINGLE



Motor continued

Table 4.34 Wiring Configuration by IE3 CE Motor

Motor kW x P	Voltage Configuration	Wiring Diagram
.75 x 4	220/380V, 50Hz Three Phase	DELTA-WYE
1.1 x 4		
1.5 x 4		
2.2 x 4		
3.0 x 4		
3.7 x 4		
5.5 x 4	380V, 50Hz Three Phase	WYE-Start DELTA-Run
7.5 x 4		
11 x 4		
15 x 4		
18.5 x 4		
22 x 4		
30 x 4		
37 x 4		
45 x 4		
55 x 4		

Figure 4.28 DELTA-WYE Diagram

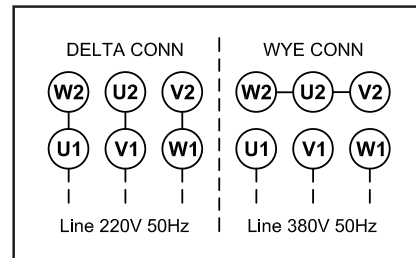
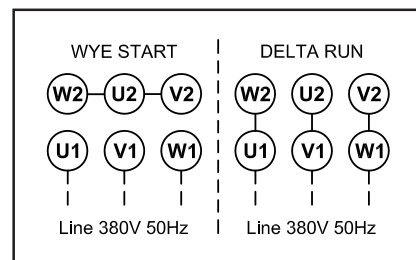

Figure 4.29 WYE-Start DELTA-Run Diagram



Motor Thermal Rating for Cyclic Applications

Table 5.35 Motor Thermal Rating Table

Motor Power HP (kW)	Allowable C x Z				Motor Inertia lb-in ² (kg-m ²)	
	below 35% ED ^[1]	35% ~ 50% ED ^[1]	50% ~ 80% ED ^[1]	80% ~ 100% ED ^[1]	Standard	with Brake
1 (0.75)	1400	1400	800	500	8.03 (0.00235)	8.82 (0.00258)
1.5 (1.1)	1400	1400	800	500	11.5 (0.00337)	13.5 (0.00396)
2 (1.5)	1200	1200	500	400	13.4 (0.00391)	15.4 (0.0045)
3 (2.2)	1000	900	400	200	30.1 (0.0088)	33.4 (0.00978)
5 (3.7)	800	800	800	700	66.3 (0.0194)	71.4 (0.0209)
7.5 (5.5)	300	300	200	150	99.4 (0.0291)	105 (0.0306)
10 (7.5)	400	350	300	300	140 (0.0409)	154 (0.045)
15 (11)	200	200	150	150	192 (0.0561)	206 (0.0602)
20 (15)	100	90	78	68	340 (0.0995)	393 (0.115)
25 (18.5)	75	65	55	50	875 (0.256)	926 (0.271)
30 (22)	75	65	55	50	875 (0.256)	926 (0.271)
40 (30)	55	40	17	10	1110 (0.326)	1170 (0.342)

Note: [1] % ED = Duty Cycle.

The calculated C x Z value (steps 1 – 3 outlined below) should be less than the allowable value listed in Motor Thermal Rating table above.

1. Obtain the C value:

$$C = \frac{I_M + I_L}{I_M}$$

I_M = Moment of Inertia of the Motor.
 I_L = Moment of Inertia of the Load as seem from the motor shaft.

2. Obtain the Z value (number of starts per hour):

(a) Assume that one operating period consists of “on-time” t_a (sec.), “off-time” t_b (sec.) and the motor is started nr (times/cycle).

$$Z_r = \frac{3600 \cdot nr}{t_a + t_b} \text{ (times/hour)}$$

(b) When inching, ni (times/cycle) is included in 1 cycling (t_a+t_b), the number of inching times per hour Z_i , is then included in the number of starts.

$$Z_i = \frac{3600 \cdot ni}{t_a + t_b} \text{ (times/hour)}$$

(c) Calculate Z by adding Z_r to Z_i by the following formula.

$$Z = Z_r + \frac{1}{2} \cdot Z_i = \frac{3600}{t_a + t_b} \cdot \left(nr + \frac{1}{2} ni \right) \text{ (times/hour)}$$

3. Calculate C x Z (the product of C and Z)

Use the value of C obtained in Step (1) and value of Z obtained in Step (2).

4. Obtain the duty cycle %ED and compare calculated C x Z in the appropriate column from Motor Thermal Rating Table.

$$\%ED = \frac{t_a}{t_a + t_b} \cdot 100$$

t_a = on-time
 t_b = off-time

Motor continued

Brakemotor Characteristics

The brakemotor on Cyclo® gearmotors operates with direct current supplied by a dual voltage rectifier for 230/460V, or single voltage rectifier/power module for other noted voltages. Rectifier or power module is mounted in the motor conduit box.

When used for outdoor installations, standard brakemotor must be protected by a cover. Such covers are available from the factory, please inquire when ordering.

Note: Advise the factory when ordering if you require brake torque greater or lesser than those shown as standard in the Brakemotor Characteristics table below.

Brake Characteristics

Table 5.36 Brake Characteristics - Standard torque, Delay Time, Work Capacity

Brake Model	Motor Capacity		Standard Braking Torque ft - lbs (N - m)	Braking Delay Time (sec)			Brake Work Capacity		
	HP x 4P	kW x 4P		Normal Braking Action		Fast Braking Action	Allowable E ₀ (J/min)	Gap Adjust (x 10 ⁷ J)	Total E ₁ (x 10 ⁷ J)
				Standard Wiring	Inverter Wiring ^[1]				
FB-01A1	1/8	0.1	0.7 (1.0)	0.15 ~ 0.2	0.08 ~ 0.12	0.015 ~ 0.02	1080	2.6	6.7
FB-02A1	1/8 ~ 1/3	0.1 ~ 0.25	1.4 (2.0)						
FB-05A1	1/4 ~ 1/2	0.2 ~ 0.4	2.9 (4.0)						
FB-1D	1/2 ~ 3/4	0.4 ~ 0.55	5.8 (7.5)	0.2 ~ 0.3	0.1 ~ 0.15	0.01 ~ 0.02	1620	7.0	33.1
FB-2D	3/4	0.55	11 (15)				2580	6.8	29.5
FB-1E	1	0.75	5.5 (7.5)	0.25 ~ 0.45	0.15 ~ 0.25	0.01 ~ 0.03	2580	11.6	38.7
FB-1HE	1.5	1.1	8.0 (11)	0.45 ~ 0.65	0.25 ~ 0.35		3360	20.8	46.3
FB-2E	2	1.5	11 (15)	0.35 ~ 0.55	0.15 ~ 0.25				
FB-3E	3	2.2	16 (22)	0.75 ~ 0.95	0.4 ~ 0.5	0.02 ~ 0.04	5720	26.3	105.3
FB-5E	5	3.7	30 (40)	1.1 ~ 1.3	0.4 ~ 0.5		6900	57.4	382.8
FB-8E	7.5	5.5	40 (55)	1.0 ~ 1.2	0.3 ~ 0.4				
FB-10E	10	7.5	59 (80)	1.8 ~ 2.0	0.6 ~ 0.7				
FB-15E	15	11	80 (110)	1.6 ~ 1.8	0.5 ~ 0.6		10800	110.2	551.1

Notes: Above table applies to standard brake specification under standard brake torque. Special brakes may perform differently from those shown. Initial brake torque may be lower than specified brake torque. If this is the case, under light load start and stop the motor to wear-in the braking surface. To improve performance for positioning accuracy or lifting applications, consider using fast braking action circuit. If the brake is operated at a rate greater than the Allowable Brake Work Capacity, E₀, the brake performance may degrade or become inoperable.

[1] Also applies to wiring where brake is powered separately from the motor leads.

Brakemotor Characteristics

Table 5.37 Brake Maintenance: Brake Gap, Lining Thickness

Brake Model	Brake Gap			Brake Lining Thickness		
	Spec. (Initial) inch (mm)	Limit inch (mm)	Adjustment Method	Spec. (Initial) inch (mm)	Limit inch (mm)	
FB-01A1	0.008 ~ 0.014 (0.2 ~ 0.35)	0.020 (0.5)	Twist detent	0.276 (7.0)	0.256 (6.5)	
FB-02A1						
FB-05A1						
FB-1D	0.012 ~ 0.016 (0.3 ~ 0.4)	0.024 (0.60)	Shim	0.347 (8.8)	0.236 (6.0)	
FB-2D					0.307 (7.8)	
FB-1E	0.010 ~ 0.014 (0.25 ~ 0.35)	0.024 (0.60)		0.347 (8.8)	0.307 (7.8)	
FB-1HE		0.030 (0.75)		0.355 (9.0)	0.315 (8.0)	
FB-2E				0.410 (10.4)	0.331 (8.4)	
FB-3E	0.014 ~ 0.018 (0.35 ~ 0.45)	0.034 (0.85)		Nut	0.394 (10.0)	0.236 (6.0)
FB-5E		0.040 (1.0)			0.433 (11.0)	0.276 (7.0)
FB-8E		0.047 (1.2)				
FB-10E						
FB-15E						

Motor continued

Brakemotor: Brake Current Rating - 60Hz

Table 5.38a Brake Current for Standard Fractional Motor and AF-Motor (AV)

Brake Model	230VAC, 60Hz			460VAC, 60Hz			575VAC, 60Hz		
	Vdc (V)	Idc (A)	Iac (A)	Vdc (V)	Idc (A)	Iac (A)	Vdc (V)	Idc (A)	Iac (A)
FB-01A1	207VDC Full Wave	0.05	0.06	207VDC Half Wave	0.05	0.04	259VDC Half Wave	0.05	0.03
FB-02A1		0.08	0.1		0.08	0.06		0.09	0.07
FB-05A1		0.1	0.1		0.1	0.1		0.1	0.1
FB-1D		0.2	0.2		0.2	0.2		0.2	0.2
FB-2D		0.2	0.2		0.2	0.2		0.2	0.2

Table 5.38b Brake Current for EP.NA Motor

Brake Model	230VAC, 60Hz			240VAC, 60Hz			460VAC, 60Hz			480VAC, 60Hz		
	Vdc (V)	Idc (A)	Iac (A)	Vdc (V)	Idc (A)	Iac (A)	Vdc (V)	Idc (A)	Iac (A)	Vdc (V)	Idc (A)	Iac (A)
FB-1E	207VDC Full Wave	0.1	0.1	216VDC Full Wave	0.1	0.1	207VDC Half Wave	0.1	0.1	216VDC Half Wave	0.1	0.1
FB-1HE		0.2	0.2		0.2	0.2		0.2	0.2			
FB-2E		0.2	0.2		0.2	0.2		0.2	0.2			
FB-3E		0.4	0.4		0.4	0.4		0.3	0.4			
FB-5E		0.4	0.4		0.5	0.5		0.4	0.3			
FB-8E		0.4	0.4		0.5	0.5		0.4	0.4			
FB-10E		0.4	0.4		0.5	0.5		0.4	0.4			
FB-15E		0.4	0.4		0.5	0.5		0.4	0.4			

Table 5.38b continued... Brake Current for EP.NA Motor

Brake Model	575VAC, 60Hz		
	Vdc (V)	Idc (A)	Iac (A)
FB-1E	259VDC Half Wave	0.1	0.1
FB-1HE		0.2	0.2
FB-2E		0.2	0.2
FB-3E		0.4	0.3
FB-5E		0.4	0.3
FB-8E		0.5	0.4
FB-10E		0.5	0.4
FB-15E		0.5	0.4

Note: Brake coil design will be specific to brake voltage specified at time of order. Check motor nameplate, to determine brake voltage rating.

Brakemotor: Brake Current Rating - 50 Hz

Table 5.39a Brake Current for Fractional Motor CE Motor

Brake Model	220VAC, 50Hz			230VAC, 50Hz			380VAC, 50Hz			400VAC, 50Hz		
	Vdc (V)	Idc (A)	Iac (A)	Vdc (V)	Idc (A)	Iac (A)	Vdc (V)	Idc (A)	Iac (A)	Vdc (V)	Idc (A)	Iac (A)
FB-01A1	99VDC Half Wave	0.13	0.12	104VDC Half Wave	0.13	0.12	171VDC Half Wave	0.06	0.04	180VDC Half Wave	0.06	0.04
FB-02A1		0.2	0.2		0.2	0.2		0.08	0.07		0.08	0.07
FB-05A1		0.3	0.2		0.2	0.2		0.1	0.1		0.1	0.1
FB-1D								0.1	0.1		0.1	0.1

Table 5.39b Brake Current for IE3 CE Motor

Brake Model	220VAC, 50/60Hz			230VAC, 50/60Hz			380VAC, 50/60Hz			400VAC, 50/60Hz				
	Vdc (V)	Idc (A)	Iac (A)	Vdc (V)	Idc (A)	Iac (A)	Vdc (V)	Idc (A)	Iac (A)	Vdc (V)	Idc (A)	Iac (A)		
FB-1E	99VDC HalfWave	0.2	0.2	104VDC HalfWave	0.2	0.2	171VDC HalfWave	0.1	0.1	180VDC HalfWave	0.1	0.1		
FB-1HE		0.5	0.4		0.5	0.4		0.2	0.2		0.2	0.2		
FB-2E		0.6	0.5		0.6	0.5		0.3	0.2		0.3	0.2	0.3	0.2
FB-3E														
FB-4E		1	0.7		1	0.8		0.4	0.3		0.4	0.3		
FB-5E		1.1	0.9		1.2	0.9		0.5	0.4		0.5	0.4		
FB-8E														
FB-10E														
FB-15E														

Notes: Brake coil design will be specific to brake voltage specified at time of order. Check motor nameplate, to determine brake voltage rating.

Motor continued

Brakemotor: Optional Brake Torques

Table 5.40 Brake Torques: Standard and Inverter

Brake Model	Motor Capacity			Braking Torque ft-lbs (N-m)				
Model	HP x 4P (ST)	HP x 4P (AV)	kW x 4P (ST)	Standard	Optional			
FB-01A1	1/8	-	0.1	0.7 (1.0)	0.25 (0.34)	0.3 (0.4)	0.4 (0.54)	0.48 (0.65)
					0.6 (0.8)	0.7 (1.0)	1.0 (1.4)	-
FB-02A1	1/4 - 1/3	1/8	0.2 - 0.25	1.4 (2.0)	0.48 (0.65)	0.6 (0.8)	0.7 (1.0)	1.0 (1.4)
					1.4 (2.0)	1.9 (2.6)	2.3 (3.1)	-
FB-05A1	1/2	1/4 - 1/3	0.37	2.9 (4.0)	0.7 (1.0)	1.0 (1.4)	1.4 (2.0)	-
					1.9 (2.6)	2.3 (3.1)	-	-
FB-1D	3/4	1/2	0.55	5.8 (7.5)	4.6 (6.2)	6.9 (9.4)	7.7 (10)	-
					3.6 (4.9)	4.3 (5.8)	5.1 (6.9)	7.2 (9.8)
FB-2D	-	3/4	-	11 (15)	8.7 (12)	13 (18)	14 (19)	-
					2.2 (3.0)	3.0 (4.0)	4.0 (5.5)	7.4 (10)
FB-1E	1	1	0.75	5.5 (7.5)	2.2 (3.0)	3.7 (5.0)	5.5 (7.5)	11 (15)
FB-1HE	1.5	-	1.1	8.0 (11)				
FB-2E	2	1.5	1.5	11 (15)	3.7 (5.0)	5.5 (7.5)	8.0 (11)	15 (20)
FB-3E	3	2	2.2	16 (22)	4.4 (6.0)	7.4 (10)	11 (15)	22 (30)
FB-5E	5	3	3.7	30 (40)	7.4 (10)	15 (20)	22 (30)	40 (55)
FB-8E	7.5	5	5.5	40 (55)	15 (20)	22 (30)	30 (40)	53 (72)
FB-10E	10	7.5	7.5	59 (80)	15 (20)	30 (40)	44 (66)	80 (110)
FB-15E	15	10	11	80 (110)	29 (40)	44 (60)	59 (80)	110 (150)

ST - Standard Motor, AV - Inverter Motor

Brakemotor Standard Wiring Connection

Models FB-01A1 through FB-15E, 230/460V, 60Hz or 575V, 60Hz

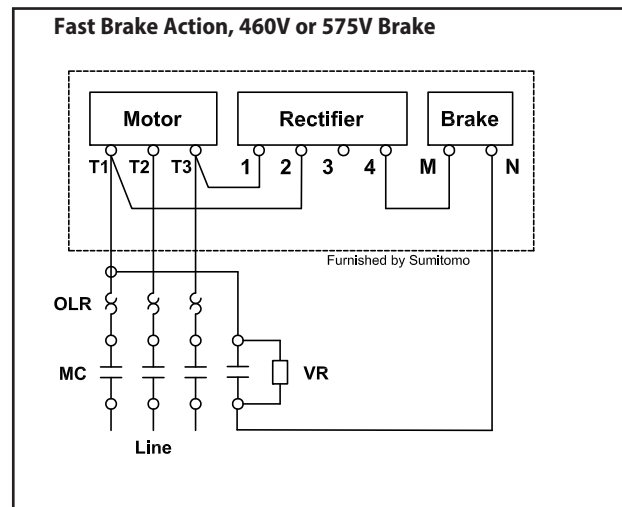
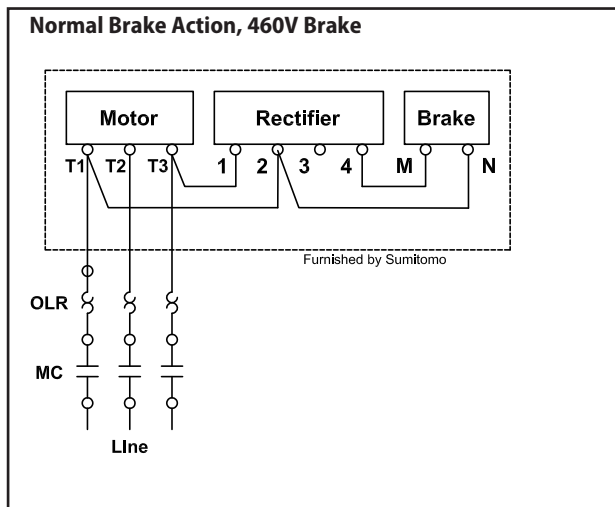
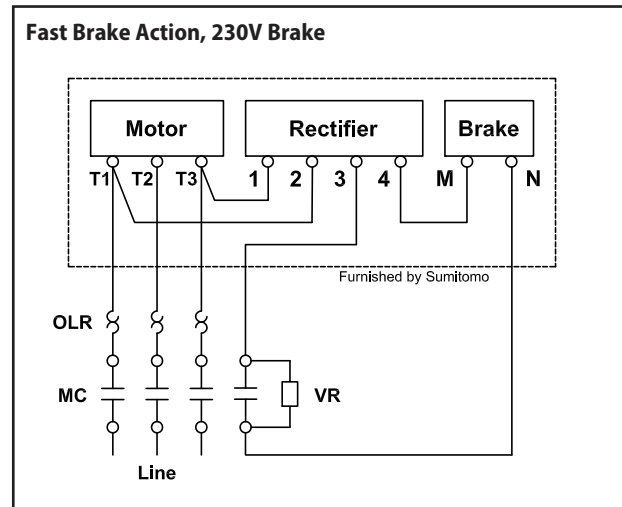
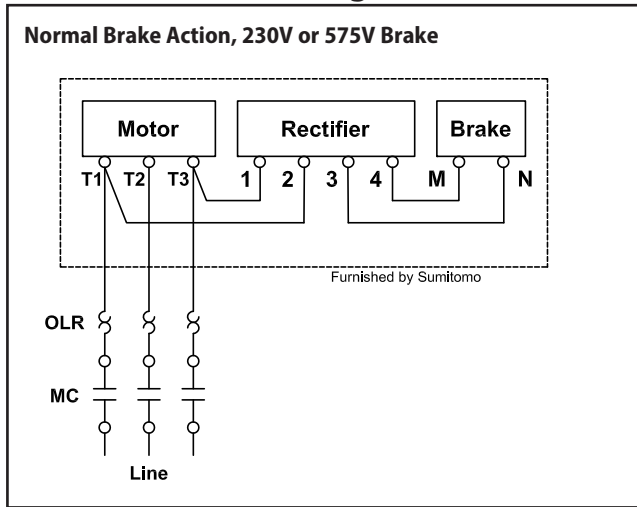

- Key:**
MC: Motor Contactor
OLR: Overload or Thermal Relay
VR: Varistor (protective device, refer to Varistor Specification Table)

Brakemotor Standard Wiring Connection

Table 5.41 Varistor Specification Table

Operating Voltage		190-230V	380-460V	575V
Varistor Rated Voltage		AC260-300V	AC510V	AC604V
Varistor Voltage		430-470V	820V	1000V
Rated Watt	FB-01A1, 02A1, 05A1	Over 0.4W	Over 0.4W	Over 0.4W
	FB-1E, 1D	Over 0.6W	Over 0.6W	Over 0.4W
	FB-1HE, 2E, 2D, 3E	Over 1.5W	Over 1.5W	Over 0.6W
	FB-5E, 8E, 10E, 15E	Over 1.5W	Over 1.5W	Over 1.5W

Motor continued

Brakemotor Inverter Wiring Connection

Models FB-01A1 through FB-15E, 230/460V, 60Hz or 575V, 60Hz

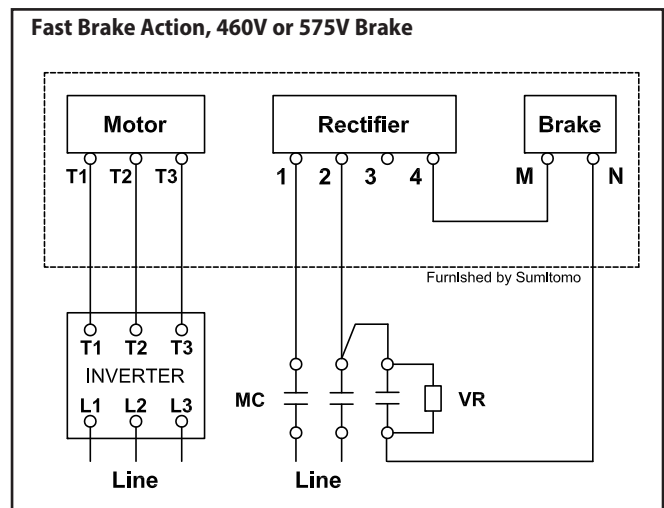
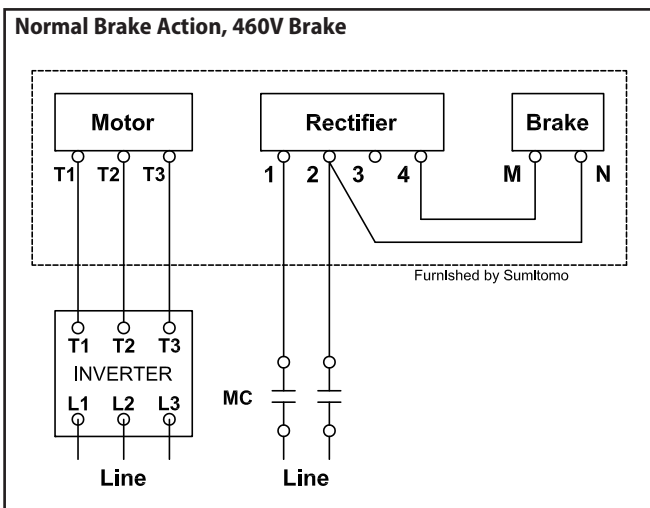
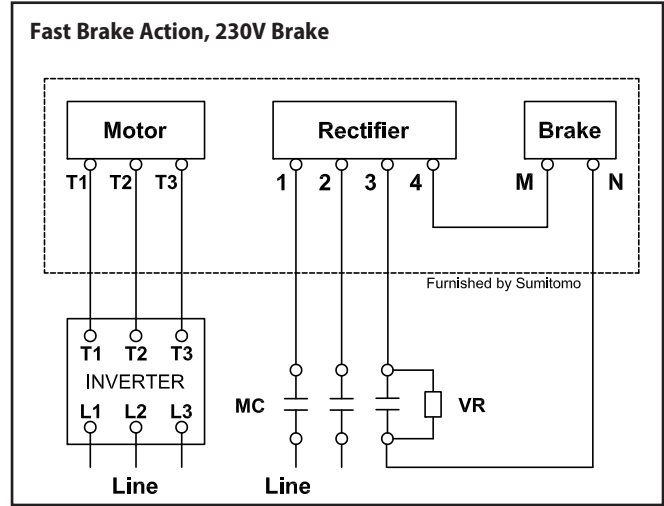
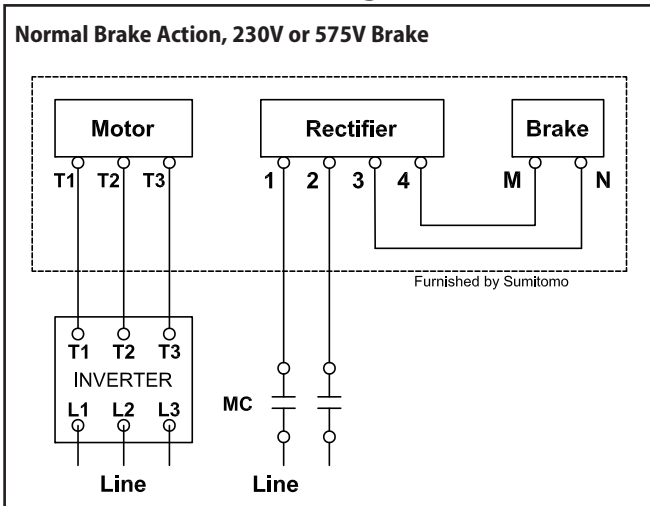

Hyponic®

Technical Information

- Key:**
MC: Motor Contactor
OLR: Overload or Thermal Relay
VR: Varistor (protective device, refer to Varistor Specification Table)

Brakemotor Inverter Wiring Connection

Table 5.42 Varistor Specification Table

Operating Voltage		190-230V	380-460V	575V
Varistor Rated Voltage		AC260-300V	AC510V	AC604V
Varistor Voltage		430-470V	820V	1000V
Rated Watt	FB-01A1, 02A1, 05A1	Over 0.4W	Over 0.4W	Over 0.4W
	FB-1E, 1D	Over 0.6W	Over 0.6W	Over 0.4W
	FB-1HE, 2E, 2D, 3E	Over 1.5W	Over 1.5W	Over 0.6W
	FB-5E, 8E, 10E, 15E	Over 1.5W	Over 1.5W	Over 1.5W

Brakemotor Standard Wiring Connection for CE Motors

Models FB-01A1 through FB-5E, 220/380V, 50Hz (see page 5.39 for wiring with inverter)

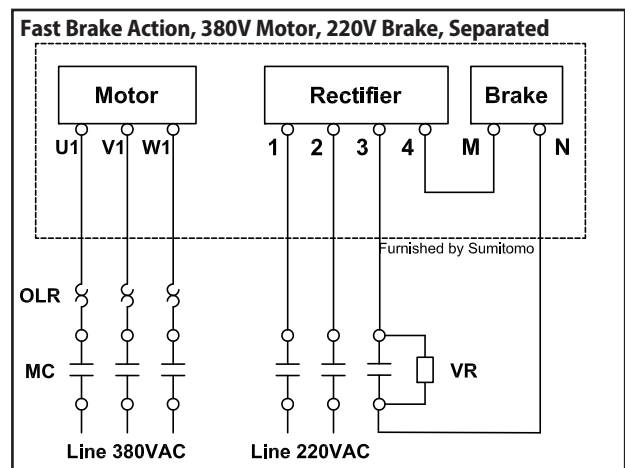
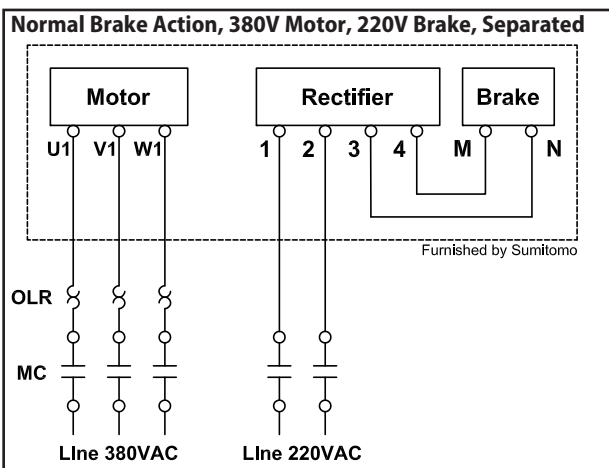
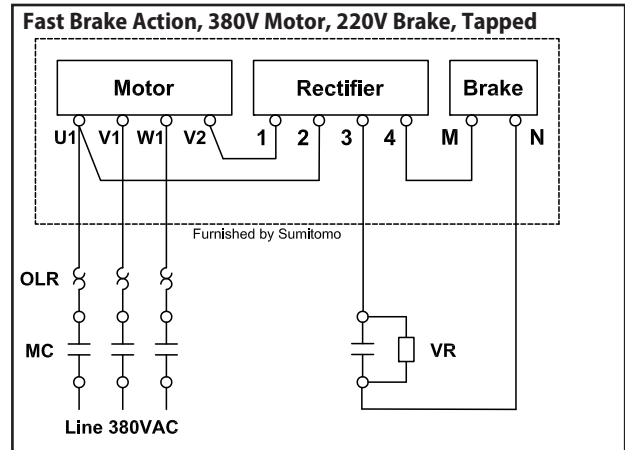
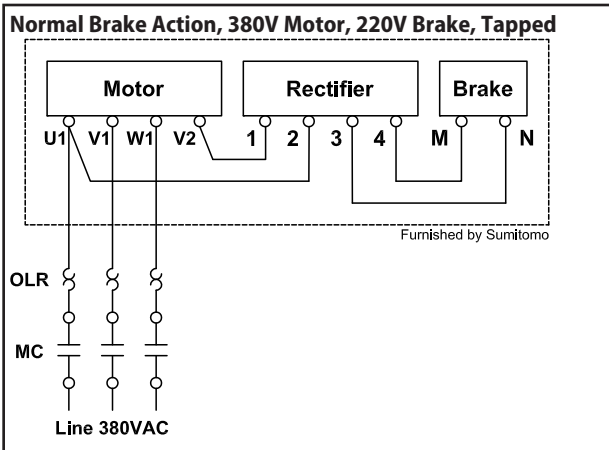
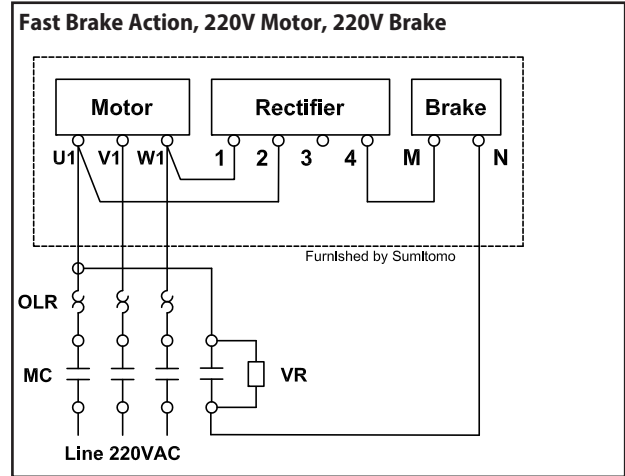
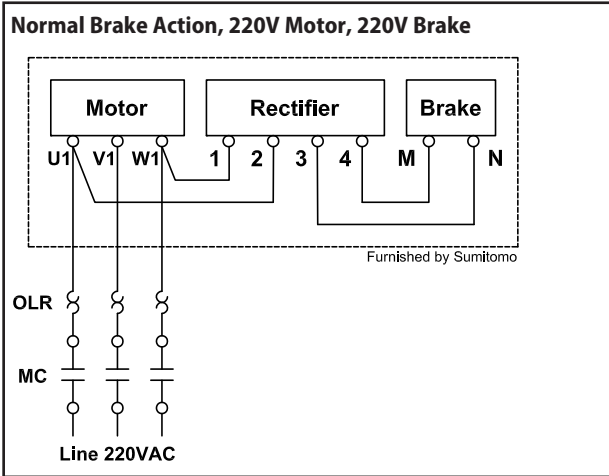

- Key:**
MC: Motor Contactor
OLR: Overload or Thermal Relay
MCB: Magnetic Circuit Breaker
VR: Varistor (protective device, refer to Varistor Specification Table on page 5.39)

Motor continued

Brakemotor Standard Wiring Connection for CE Motors (continued)

Models FB-8E through FB-15E, 380V, 50Hz

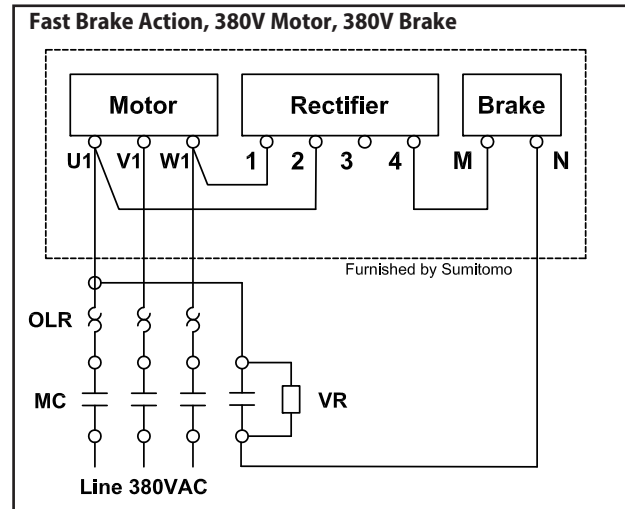
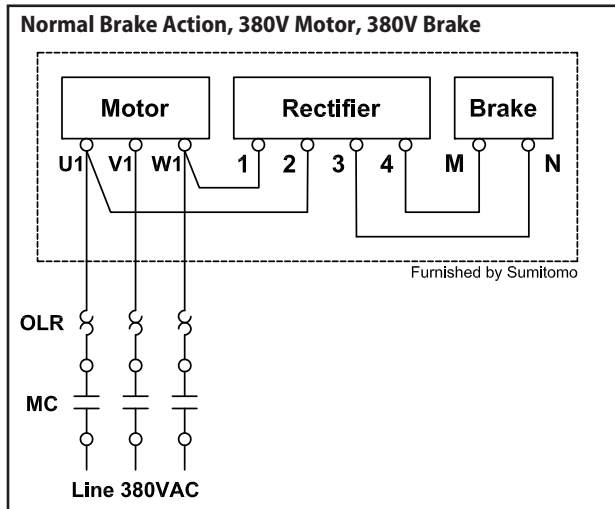

Models FB-01A1 through FB-15E with Inverter 220/380V, 50Hz

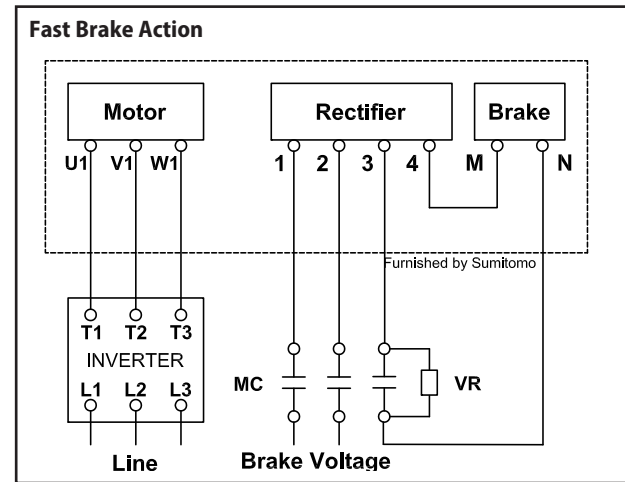
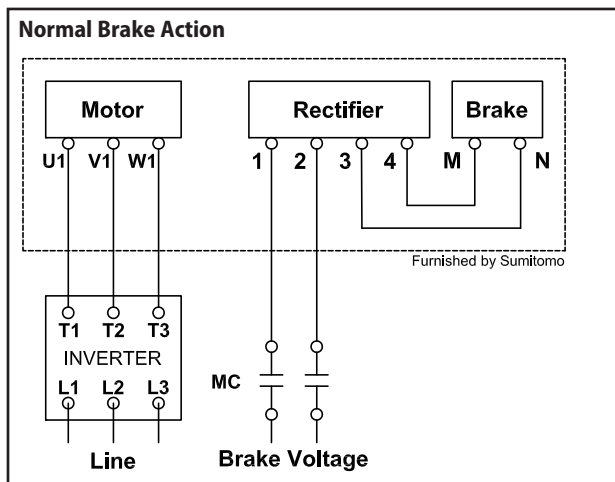

Key: MC: Motor Contactor OLR: Overload or Thermal Relay VR: Varistor (protective device, refer to Varistor Specification Table)

Table 5.43a CE Motor, Motor/Brake Voltage Table

Motor Power kW x 4P	Brake Model	Motor Voltage	Brake Voltage
0.1	FB-01A1	220/380V, 50Hz	220V, 50Hz*
0.2, 0.25	FB-02A1		
0.37	FB-05A1		
0.55	FB-1D		
0.75	FB-1E		
1.1	FB-1HE		
1.5	FB-2E		
2.2	FB-3E		
3.0	FB-4E		
3.7	FB-5E		
5.5	FB-8E	380V, 50Hz	380V, 50Hz
7.5	FB-10E		
11	FB-15E		

Table 5.43b Varistor Specification Table

	Operating Voltage	220V	380V
	Varistor Rated Voltage	AC300V	AC510V
Varistor Voltage	470V	820V	
Rated Watt	FB-01A1, 02A1, 05A1	Over 0.4W	Over 0.4W
	FB-1E, 1D	Over 0.6W	Over 0.6W
	FB-1HE, 2E	Over 1.5W	Over 1.5W
	FB-3E, 4E	Over 1.5W	Over 1.5W
	FB-5E, 8E	Over 1.5W	Over 1.5W
	FB-10E, 8E	Over 1.5W	Over 1.5W

*optional 380V 50Hz Brake Available

Brake Rectifiers and Brake Power Modules

Table 5.44a Brake Rectifiers for Fractional Motors

Brake Type	Motor Power HP x P	230V/460V Rectifier		575V Rectifier	
		Model Number	Part Number	Model Number	Part Number
FB-01A1	1/8 X 4	25FW-4FB3	EY477WW-01	10F-6FB3	EY498WW-01
FB-02A1	1/4 - 1/3 X 4				
FB-05A1	1/2 X 4				
FB-1D	3/4 X 4				
FB-20	3/4 X 4				

Table 5.44b Brake Rectifiers for Fractional Motors

Brake Type	Motor Power kW x P	220V Rectifier	
		Model Number	Part Number
FB-01A1	0.1 X 4	10F-2FB2	MP983WW-01
FB-02A1	0.2 - 0.25 X 4		
FB-05A1	0.37 X 4		
FB-1D	0.55 X 4		

Table 5.44c Brake Rectifiers for EP.NA Motors

Brake Type	Motor Power HP x P	230V/460V Rectifier		575V Rectifier	
		Model Number	Part Number	Model Number	Part Number
FB-1E	1 x 4	25FW-4FB3	EY477WW-01	10F-6FB3	EY498WW-01
FB-1HE	1.5 x 4				
FB-2E	2 x 4				
FB-3E	3 x 4				
FB-5E	5 x 4				
FB-8E	7.5 x 4				
FB-10E	10 x 4				
FB-15E	15 x 4				

Table 5.44d Brake Rectifiers for IE3 CE Motors

Brake Type	Motor Power kW x P	220V Rectifier		380V Rectifier	
		Model Number	Part Number	Model Number	Part Number
FB-1E	0.75 x 4	10F-2FB2	MP983WW-01		
FB-1HE	1.1 x 4				
FB-2E	1.5 x 4				
FB-3E	2.2 x 4				
FB-4E	3.0 x 4				
FB-5E	3.7 x 4 4.0 x 4				
FB-8E	5.5 x 4			05F-4FB2	MP985WW-01
FB-10E	7.5 x 4				
FB-15E	11 x 4			15F-4FB1	EW397WW-01

Hyponic®

Technical
Information

Warranty

Company warrants that (i) all new equipment and parts (collectively, "Equipment") sold by Company will conform to printed drawings and specification sheets issued by Company and (ii) are free of defects in material and workmanship for the time period shown in Table 1. The warranty period commences on the date of shipment of the Equipment by Company.

If, within the warranty period, Company receives from Buyer written notice of any alleged defect in any of the Equipment and, if the Equipment is found by Company not to conform with these warranties (after Buyer has provided Company a reasonable opportunity to perform any appropriate tests on the allegedly defective Equipment), Company will, at its sole option and expense, either repair or replace the Equipment. In all instances, Company reserves the right to require Buyer to deliver the Equipment for repair or replacement to a designated service center and require Buyer to pay all charges for inbound and outbound transportation and for services of any kind, diagnostic or otherwise, excepting only the direct and actual cost of Equipment repair or replacement. Warranty coverage is limited to parts and labor and does not include travel and other expenses. Buyer applications and use of the Equipment may require installation of safety features. Buyer is responsible for furnishing and installing guards or other safety equipment needed to protect operating personnel, even though such equipment may not be furnished by Company with the Equipment purchased. Equipment supplied, but not manufactured, by Company is warranted only to the extent of the original manufacturer's warranty.

Table 5.45 - Product Warranty

Product	Warranty Period (After Shipment)	Components Excluded
Cyclo® Speed Reducers and Gearmotors	2 Years	Normally Wearing Items
Cyclo® Bevel Buddybox Speed Reducers and Gearmotors	2 Years	Normally Wearing Items
Cyclo® Helical Buddybox Speed Reducers and Gearmotors	2 Years	Normally Wearing Items
Fine Cyclo® Speed Reducers	2 Years	Normally Wearing Items
Beier® Variator Mechanical Adjustable Speed Reducers	2 Years	Normally Wearing Items
Hyponic® Speed Reducers and Gearmotors	2 Years	Normally Wearing Items
Hedcon® Double Enveloping Worm Gear Speed Reducers	2 Years	Normally Wearing Items
Helical Shaft Mount Speed Reducers	2 Years	Normally Wearing Items
Rhytax®	2 Years	Normally Wearing Items
IB Series Servo Gearheads	1 Year	Normally Wearing Items
Astero Gearmotors	1 Year	Normally Wearing Items
Variable Frequency Inverters	1 Year	---
Paramax® Speed Reducers	2 Years	Normally Wearing Items
Compower Planetary Speed Reducers	1 Year	Normally Wearing Items
Hansen UniMiner	2 Years	Normally Wearing Items
Hansen P4	2 Years	Normally Wearing Items
Parts	1 Year	---
Repairs	1 Year	Normally Wearing Items